



**PENTALIFT EQUIPMENT CORPORATION**

**PENTALOCK MFRAL32 VEHICLE  
RESTRAINT  
(AUTOMATIC LIGHTS)**

**OWNERS MANUAL**

**SERIAL NUMBER :** \_\_\_\_\_

Individual Serial Number(s) must be filled out by the user for future reference.

**This manual is an important document.**

It shall be kept with the machine or located where readily available to operators and maintenance personnel for reference purposes. Do not install, operate or service this product unless you have read and fully understand the entire contents of this manual. Failure to do so may result in property damage, bodily injury or death. Keep this manual in a safe place for future reference.

**NOTE:** A very high level of field issues with this type of equipment can be directly attributed to improper or incomplete installation. The installation instructions and information provided for this equipment is thorough. A step by step sequence for installation is provided. All steps must be followed and completed to provide a complete installation. Incomplete or improper installations can lead to equipment malfunction and / or damage, create safety issues and void warranties. Please follow all installation and set ups steps as indicated in the installation instructions and owner's manual. If you are unclear or uncertain regarding any of the steps contact your Pentalift representative for clarification. A copy of the completed steps listing with the sign off and photos of the installation as indicated at the conclusion of the installation instructions will be required prior to any Pentalift factory trouble shooting assistance.

**Pentalift Equipment Corporation  
21 Nicholas Beaver Rd  
Puslinch, ON N0B 2J0  
Phone: 519-763-3625  
Fax: 519-763-2894  
Parts Phone: 519-763-3625 Extension 625  
Ask for Parts Department**

**Pentalift Equipment Corporation provides an owners manual when equipment is shipped. Additional manuals are available at \$25.00 each.**

**IMPORTANT:** The owners manuals that are provided on Pentalift Equipment Corporations website are generic in nature. They are provided for general information only. For all purposes, only the owners manual that is specific to the equipment should be referenced and relied on. In order to receive the specific owners manual for specific Pentalift equipment, please contact your Pentalift representative and supply the specific serial number(s) for the equipment the manual is required for. Do not rely on the information in the generic owners manuals provided through the website as it may not be appropriate for your specific Pentalift equipment.

*Generic manual for reference only. Contact Pentalift with product serial number to receive owners manual for your specific equipment.*

Generic manual for reference only. Contact Pentalift with product serial number to receive owners manual for your specific equipment.

# PRODUCT REGISTRATION

# PRODUCT REGISTRATION



### PRODUCT REGISTRATION CARD

To validate warranty and to advise of product updates please complete the following information and return to

**Pentalift Equipment Corporation**

To validate warranty on-line go to: [www.pentalift.com](http://www.pentalift.com)

#### End User Information

|  |              |                           |
|--|--------------|---------------------------|
| *Company Name:   |              |                           |
| Contact *First Name:   | *Last Name:  | Title:                    |
| *Mailing Address:  |              |                           |
| *City:   | *State/Prov. | *Zip/Postal Code:         |
| *Phone: ( ) -  | Fax: ( ) -   | Email:                    |
| Check Products Purchased: <input type="checkbox"/> Levelers, <input type="checkbox"/> Vehicle Restraints, <input type="checkbox"/> Seals/Shelters,<br><input type="checkbox"/> Elevating Docks, <input type="checkbox"/> Lift Tables |              |                           |
| *Serial Number(s):   |              | Invoice # (if available): |
| Dealer Name:   |              | Sales Rep.:               |
| Manual Verification *Manual Number:  |              |                           |

\*Indicates information that must be provided.

Please return to:

Pentalift Equipment Corporation  
P.O. Box 1510,  
Buffalo, NY 14240-1510

or

Pentalift Equipment Corporation  
21 Nicholas Beaver Rd  
Puslinch, Ontario N0B 2J0

Attention: Service Department

Or Fax to (519) 763-2894

# SAFETY INFORMATION AND WARNINGS



**READ THESE SAFETY PRACTICES BEFORE INSTALLING, OPERATING OR SERVICING THE PENTALOCK MFRAL32 VEHICLE RESTRAINT. FAILURE TO FOLLOW THESE SAFETY PRACTICES MAY RESULT IN PROPERTY DAMAGE, BODILY INJURY OR DEATH.**

THE OPERATION OF THIS EQUIPMENT IS SUBJECT TO CERTAIN HAZARDS THAT CAN BE PROTECTED AGAINST ONLY BY THE EXERCISE OF CARE AND COMMON SENSE AND NOT BY MECHANICAL MEANS. IT IS, THEREFORE, ESSENTIAL TO HAVE COMPETENT, QUALIFIED OPERATORS TRAINED IN THE SAFE OPERATION AND CARE OF THIS TYPE OF EQUIPMENT. ALL PERSONNEL MUST COMPLETELY UNDERSTAND THIS SAFETY INFORMATION BEFORE WORKING ON OR NEAR THIS EQUIPMENT.



**DANGER** indicates an imminently hazardous situation which, if not avoided, will result in death or serious injury.



**WARNING** indicates a potentially hazardous situation which, if not avoided, could result in death or serious injury.



**CAUTION**, used with the safety alert symbol, indicates a potentially hazardous situation which, if not avoided, could result in minor or moderate injury.



**NOTICE** is used to address practices not related to personal injury.



Before doing any installation, maintenance, inspection or trouble shooting, barricade all areas from traffic around the work area inside (and outside if applicable) for safety and post appropriate warning signs.



Arc flash and shock hazard PPE (personal protection equipment) required. De-energize equipment before working on or inside. Do not open cover without appropriate PPE. Refer to NFPA 70E for PPE requirements. This panel may contain more than one power source. Hazardous voltage will cause severe injury or death.



Before doing any electrical work, be certain that the power is disconnected with a fused disconnect, properly tagged and locked out. Fused disconnect and lockout device (supplied and installed by others) must meet with all applicable codes and regulations. All electrical work must be performed by a qualified electrician in accordance with all applicable codes and regulations.



It is the responsibility of others to ensure the proper mounting of any wall mounted equipment such as remote power units, control panels and light packages and to ensure that the mounting surface is capable of fully supporting the loads generated by the equipment.



Regarding use with Vertical Storing Dock levelers:  
In order to manually engage or disengage the vehicle restraint using the vehicle restraint push bar the operator must enter the operating path of the vertical storing dock leveler. To prevent possible injury, it is imperative that prior to entering the operating path of the vertical storing dock leveler for any reason, including for the purpose of activating or storing the MFR restraint, that the operator confirms that the vertical storing dock leveler maintenance stand has been engaged. Once the vehicle restraint has been operated, confirm that the vertical storing dock leveler maintenance stand has been disengaged before attempting to operate the vertical storing dock leveler.

1. Do not load/unload any truck without visually confirming that the vehicle restraint has securely engaged the truck's R.I.G. (Rear Impact Guard) and the appropriate signal lights are illuminated as indicated by the operating instructions in the Owners Manual and on the control panel. If the vehicle restraint fails to engage the truck's R.I.G. for any reason, be certain to restrain the truck with appropriate alternate means and to follow the override procedures listed in this manual before proceeding with any loading/unloading.
2. Never stand between the dock and a truck.
3. Stay clear of operating path at all times.
4. When not in use, the restraint must always be in the stored position.
5. Regular inspection and maintenance must be performed to keep the equipment in proper operating condition in accordance with the detailed instructions in this manual. (See the MAINTENANCE & LUBRICATION section of this manual on page 20)
6. Ensure that the equipment is not used by anyone if you believe that any part of it might be in disrepair (e.g. bent structural members, broken welds, etc.). See Warranty Section.
7. If you have any questions, contact your immediate supervisor or your authorized Pentalift representative for assistance.
8. Do not use the VEHICLE RESTRAINT while under the influence of drugs or alcohol.

Generic manual for reference only. Contact Pentalift with product serial number to receive owners manual for your specific equipment.

# OWNER RESPONSIBILITY

The Owner's Responsibilities include the following:

- 6.3.1 The owner should recognize inherent danger of the interface between dock and transport vehicle. The owner shall, therefore, train and instruct loading dock operating personnel in the proper use of restraining devices in accordance with information provided in Section 6.1.2.
- 6.3.2 Nameplates, cautions, instructions, posted warnings and communication lights shall not be obscured from the view of loading dock operating personnel or maintenance personnel for whom such warnings are intended (also see 6.1.3 and 6.3.5).
- 6.3.3 Manufacturer's recommended periodic maintenance and inspection procedures in effect at date of shipment shall be followed, and written records of the performance of these procedures should be kept.
- 6.3.4 Restraining devices that are structurally damaged shall be removed from service, inspected by the manufacturer's authorized representative, and repaired as needed before being placed back in service.
- 6.3.5 The manufacturer shall supply replacement nameplates, communication lights, caution or instructional labels, and operating and maintenance manuals upon request of the owner. The owner shall see that all nameplates, communication lights, and caution and instruction markings or labels, are in place and legible and that the appropriate operating and maintenance manuals are provided to users (see also 6.1.3 and 6.3.2).
- 6.3.6 Modifications or alterations of restraining devices shall be made only with written permission of the original manufacturer. These changes shall be in conformance with all applicable provisions of this standard and shall be at least as safe as the equipment was before modification. These changes shall also satisfy all safety recommendations of the original equipment manufacturer for the particular application of the restraint.
- 6.3.7 When industrial vehicles are driven on or off a transport vehicle during loading or unloading operation, the parking brakes on the transport vehicle shall be applied and wheel chocks or another vehicle restraint that provides equal or better protection shall be engaged. Also, whenever possible air-ride suspension systems should have the air exhausted prior to performing said loading or unloading operations.
- 6.3.8 When a vehicle restraint is unable to properly engage a transport vehicle, the user shall activate the applicable communication if so included, or provide an alternate method to address a "not restrained vehicle condition" to alert and or protect the loading dock operating personnel.
- 6.3.9 When selecting a restraining device, it is important to consider not only present requirements but also future plans or adverse environments.
- 6.3.10 The restraint should never be used in a manner not intended by its design. It must also be compatible with the loading dock equipment and other conditions relating to the loading dock area.

**⚠ DANGER** **NOTE:** The MH30 Committee recognizes the devices intended to secure a transport vehicle to a loading dock by mechanical means. The NHTSA Standard 49CFR ch.V 571.223 specifies the strength of the rear impact guard and 49 CFR Ch.V 571.224 specifies the size and locations of the rear impact guard. It is, therefore, recommended that users of such positive restraint devices review:

- The means of attachment to the transport vehicle
- The strength of the overall connection
- The proper coordination of the actuation of devices with any signaling system used
- The need to use wheel chocks

**⚠ DANGER** Unless specifically agreed to in writing by Pentalift Equipment Corporation at the time the equipment is ordered and prior to the equipment's manufacture, this equipment is sold as a complete package. It is not to be altered, changed or added to in any way or form, in its configuration and function, without the written permission of Pentalift Equipment Corporation.

# TABLE OF CONTENTS

|   |    |
|---|----|
| PRODUCT REGISTRATION .....                                      | I  |
| SAFETY INFORMATION AND WARNINGS.....                            | II |
| OWNER RESPONSIBILITY.....                                       | IV |
| TABLE OF CONTENTS .....   | 1  |
| PRECAUTIONARY LABELING .....                                    | 2  |
| INSTALLATION INSTRUCTIONS .....                                 | 3  |
| WELDING REFERENCE INFORMATION .....                             | 6  |
| OPTIONAL EXTENSION PLATE INSTALLATION INSTRUCTIONS .....        | 7  |
| OPTIONAL HORIZONTAL (SURFACE) MOUNTED RESTRAINT.....            | 9  |
| INSTALLATION INSTRUCTIONS (MODEL MFRAL32SM).....                | 9  |
| ELECTRICAL INSTALLATION INSTRUCTIONS .....                      | 11 |
| OPERATION AND PERFORMANCE CHECK .....                           | 13 |
| OPERATING INSTRUCTIONS.....                                     | 15 |
| VEHICLE RESTRAINT STORED/DOCK EMPTY .....                       | 15 |
| TRAILER IN POSITION .....                                       | 15 |
| What to do if the R.I.G CANNOT BE ENGAGED BY the RESTRAINT..... | 19 |
| LOADING / UNLOADING COMPLETE.....                               | 19 |
| MAINTENANCE AND LUBRICATION .....                               | 20 |
| ADJUSTMENT OF RESTRAINT ENGAGE HEIGHT .....                     | 22 |
| TROUBLE SHOOTING GUIDE .....                                    | 23 |
| SETTING THE STORED LIMIT SWITCH ADJUSTMENTS.....                | 25 |
| RESTRAINT ADJUSTMENTS.....                                      | 25 |
| REPLACEMENT PARTS .....   | 27 |
| RESTRAINT REPLACEMENT PARTS LIST .....                          | 28 |
| CONTROL PANEL REPLACEMENT PARTS .....                           | 29 |
| DELUXE OUTSIDE LIGHT REPLACEMENT PARTS .....                    | 30 |
| REPLACEMENT SIGNS.....  | 31 |
| LIST OF ILLUSTRATIONS.....                                      | 32 |
| PENTALIFT EQUIPMENT CORPORATION WARRANTY.....                   | 33 |

Generic manual for reference only. Contact Pentalift with product serial number to receive owners manual for your specific equipment.

# PRECAUTIONARY LABELING

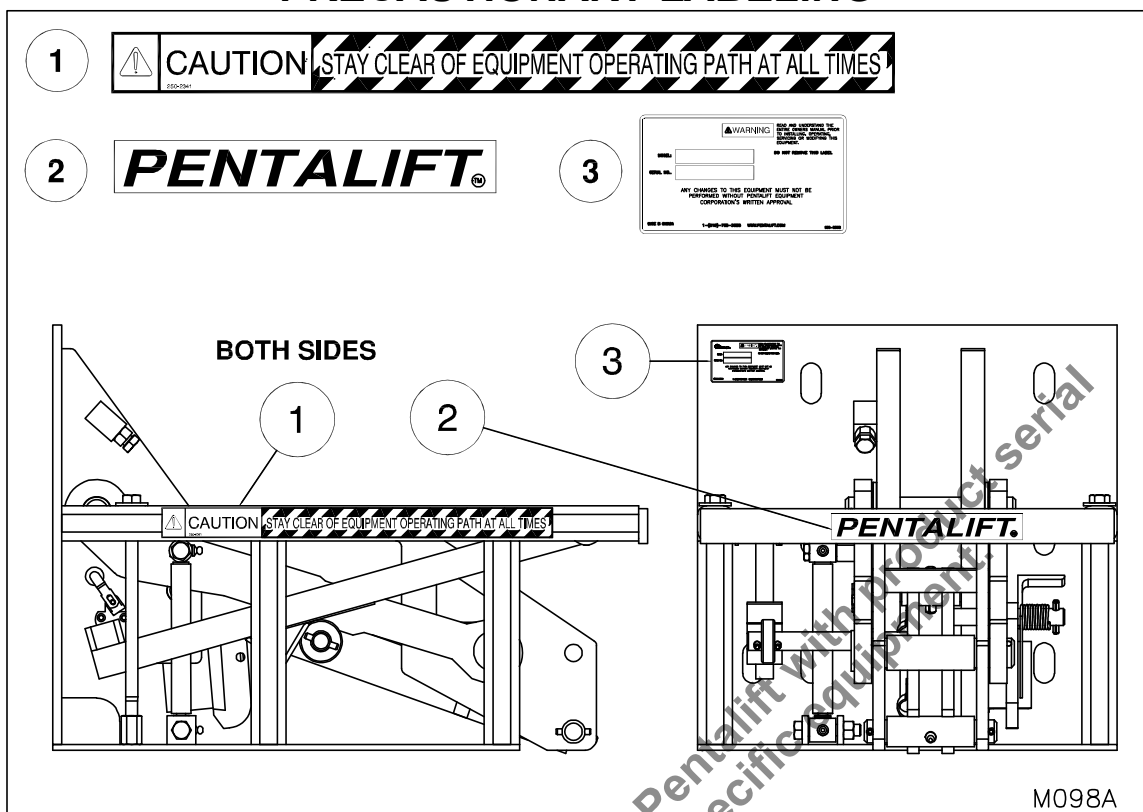

Figure 1: Precautionary Labels

Be sure that all labeling is in place and intact when the unit is received. If any of the precautionary labels or decals are missing or illegible, contact your Pentalift representative for immediate replacement.

**NOTE:** In some instances when it is not practical to place the labels on the equipment, the labels will be supplied on a separate placard. It is the owner's responsibility to confirm appropriate mounting location of the placard and have the placard visible and confirm on a regular basis that the placard continues to be visible to the operators and people working with or in close proximity of the equipment.

**Note:** In some instances, product configuration and / or product options may dictate that the product labels will not be placed as indicated on the drawing (Figure 1: Precautionary Labels). Different label locations will be selected at the factory, when required, to avoid the viewing of the label being impaired. Note the label locations as supplied on the product, when it is received to accommodate future label replacement requirements.

**NOTE:** It is the owner's responsibility to ensure that all precautionary labeling remains legible and in its original position throughout the life of the product. It is also the owner's responsibility to ensure that all labels are and will continue to be readily visible to the operators and people working with or around the equipment. If the visibility of any label is compromised for any reason then; either 1) Rectify the situation to allow the label to be readily visible 2) Order replacement label(s) from Pentalift for installation in a location that does facilitate complete visibility. Inspection shall be done during regular maintenance and lubrication (See "MAINTENANCE AND LUBRICATION" on page 20).

| <u>Item</u> | <u>Part No.</u> | <u>Qty/Unit</u> | <u>Description</u>                   |
|-------------|-----------------|-----------------|--------------------------------------|
| 1           | 250-2341        | 2               | "CAUTION Stay clear of equipment..." |
| 2           | 250-1143        | 1               | "Pentalift"                          |
| 3           | 250-2368        | 1               | Specification Plate                  |

**NOTE:** State Model # and Serial # when ordering replacement parts.

# INSTALLATION INSTRUCTIONS



**Do not install, operate or service this product unless you have read and fully understand the entire contents of this manual. Failure to do so may result in property damage, bodily injury or death.**

**NOTE:** A very high level of field issues with this type of equipment can be directly attributed to improper or incomplete installation. The installation instructions and information provided for this equipment is thorough. A step by step sequence for installation is provided. All steps must be followed and completed to provide a complete installation. Incomplete or improper installations can lead to equipment malfunction and / or damage, create safety issues and void warranties. Please follow all installation and set ups steps as indicated in the installation instructions and owner's manual. If you are unclear or uncertain regarding any of the steps contact your Pentalift representative for clarification. A copy of the completed steps listing with the sign off and photos of the installation as indicated at the conclusion of the installation instructions will be required prior to any Pentalift factory trouble shooting assistance.

---

## IMPORTANT

### PREPARATION PRIOR TO INSTALLATION

---

Follow all installation instructions in the precise consecutive order that they are written. If the equipment cannot be installed in the order as outlined below, contact Pentalift Equipment Corporation for written instructions on how to proceed. Do not proceed with an alternate installation method unless written confirmation has been provided by Pentalift Equipment Corporation. To accommodate a complete installation there is a blank space provided beside each numbered step in the installation instructions. Please check off the steps sequentially as they are completed. This will assist in confirming a complete installation.



**Before doing any installation, maintenance, inspection or trouble shooting, barricade all areas from traffic around the work area inside (and outside if applicable) for safety and post appropriate warning signs.**



**Before doing any electrical work, be certain that the power is disconnected with a fused disconnect, properly tagged and locked out. Fused disconnect and lockout device (supplied and installed by others) must meet with all applicable codes and regulations. All electrical work must be performed by a qualified electrician in accordance with all applicable codes and regulations.**



**Arc flash and shock hazard PPE (personal protection equipment) required. De-energize equipment before working on or inside. Do not open cover without appropriate PPE. Refer to NFPA 70E for PPE requirements. This panel may contain more than one power source. Hazardous voltage will cause severe injury or death.**



**MAKE SURE LIFTING AND SLINGING DEVICES ARE OF SUFFICIENT CAPACITY, USED IN THE CORRECT MANNER AND ARE IN GOOD WORKING ORDER. ALL LIFTING, POSITIONING AND INSTALLATION, AS WELL AS THE BREAK-IN AND PERFORMANCE CHECK MUST BE DONE BY QUALIFIED PERSONNEL TRAINED AND EXPERIENCED IN NECESSARY SAFETY PROCEDURES.**



**It is the responsibility of others to ensure the proper mounting of any wall mounted equipment such as remote power units, control panels and light packages and to ensure that the mounting surface is capable of fully supporting the loads generated by the equipment.**

## **WARNING**

THIS RESTRAINT IS DESIGNED TO OPERATE WITH THE FACE OF THE DOCK BUMPERS EXTENDED 4" PAST THE POSITION OF THE BACK PLATE OF THE RESTRAINT ONCE IT IS INSTALLED. THIS DIMENSION RELATIONSHIP IS CRITICAL TO ASSURING THE PROPER OPERATIONAL POSITIONING OF THE RESTRAINT. PRIOR TO COMMENCING WITH THE INSTALLATION, CONFIRM THAT THE ABOVE NOTED RELATIONSHIP BETWEEN THE DOCK BUMPER AND THE RESTRAINT WILL EXIST ONCE THE INSTALLATION IS COMPLETED. ONCE THIS IS CONFIRMED, COMMENCE THE INSTALLATION. IF THE PROPER RELATIONSHIP WILL NOT EXIST, A RESTRAINT INSTALLATION EXTENSION PLATE MAY BE REQUIRED. CONSULT YOUR AUTHORIZED REPRESENTATIVE FOR ASSISTANCE.

1. \_\_\_ Ensure concrete and anchor bolts have sufficient strength to meet the draw pull forces which will be applied simultaneously. (See "Figure 2: Draw Pull Forces" on page 4).
2. \_\_\_ Mark the centerline of the dock and the centerline of the restraint back plate.
3. \_\_\_ Position the MFRAL32 by matching the centerline of the dock and the centerline of the restraint back plate (See "Figure 4: Shim Locations" on page 5).

## **NOTICE**

THE RESTRAINT MUST BE AT FINISHED DRIVEWAY LEVEL AND FLUSH WITH THE FOUNDATION WALL.

4. \_\_\_ Remove the guard assembly from the restraint (See "Figure 3: Remove/Replace the Guard Assembly" on page 5).
5. \_\_\_ If the wall and/or ground are not square with respect to the back plate and the bottom plate of the restraint, metal shims must be inserted to prevent the back plate from twisting during lagging to the wall (See "Figure 4: Shim Locations" on page 5).
6. \_\_\_ If the dock face is equipped with a cast in weld plate, proceed to step 8. Otherwise, drill the required holes into the foundation wall, using the back plate of the restraint as a template.

7. \_\_\_ Recommended fasteners are  $\frac{3}{4}$ " diameter x minimum 7" long wedge anchors with a minimum shear value of 18,500 lbs (8,390kg), and a tension value of 16,400 lbs (7,440 kg). Torque to manufacturers specifications.

8. \_\_\_ If a weld plate has been pre-cast into the foundation, apply a  $\frac{3}{8}$ " fillet weld  $3\frac{1}{2}$ " long at 6" intervals around the two sides and the top of the back plate. Also, weld all slots in the back plate to the foundation weld plate. For more information, see WELDING REFERENCE INFORMATION on page 6 as well as "Figure 6: Weld Locations" on page 6.

9. \_\_\_ Weld all shims in a stack to each other as well as to the back plate.

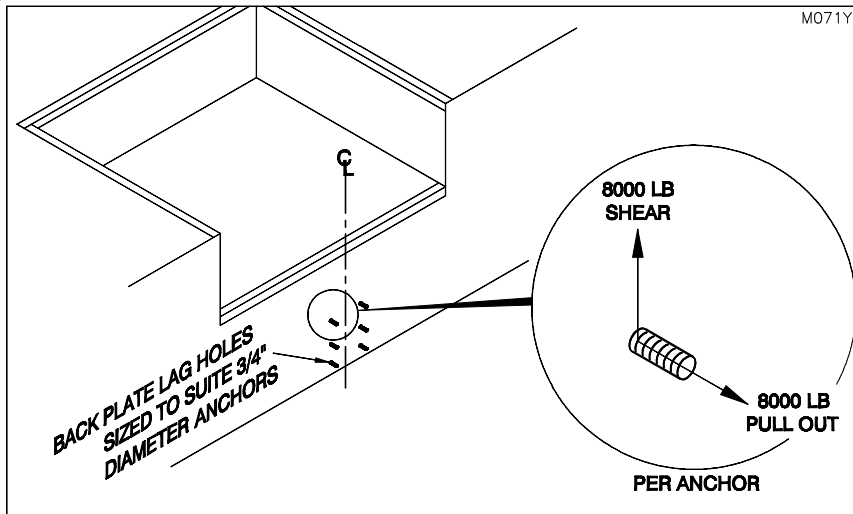
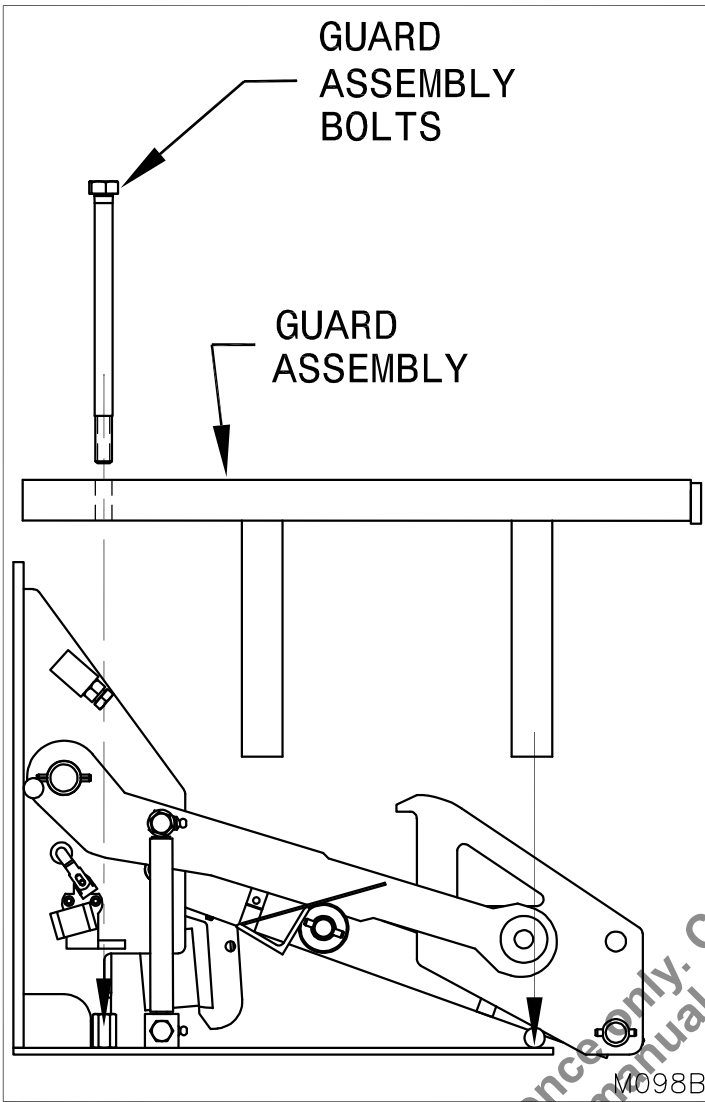
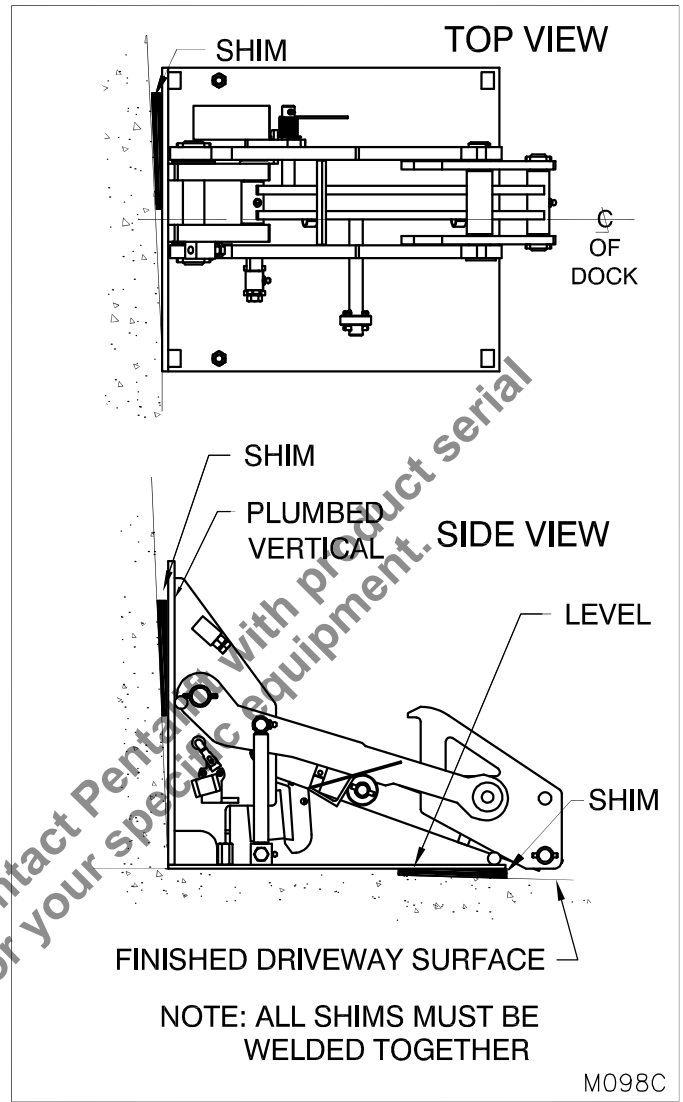

Figure 2: Draw Pull Forces

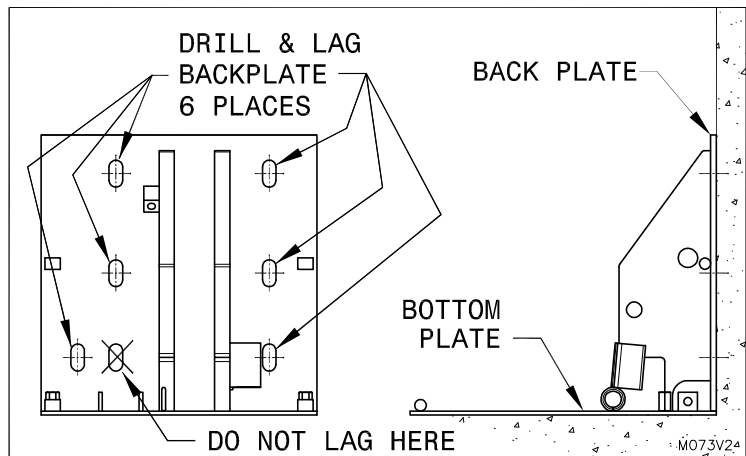

**Figure 3: Remove/Replace the Guard Assembly**



**Figure 4: Shim Locations**

10. \_\_\_ Lubricate all pivot points (See "MAINTENANCE AND LUBRICATION" on page 20)
11. \_\_\_ Clean and Paint Welds using Tremclad High Performance Rust Enamel (Gloss Dark Machine Grey) if unit is not zinc coated. If unit is zinc coated, use Tremclad Gloss Aluminum Rust paint.
12. \_\_\_ Re-install the Guard Assembly (See "Figure 3: Remove/Replace the Guard Assembly" on page 5).
13. \_\_\_ Test operation (see "OPERATION AND PERFORMANCE CHECK" on page 13)
14. \_\_\_ Check the raised height of the restraint and ensure that it is properly set. If adjustment is required follow the adjustment instructions. (see "ADJUSTMENT OF RESTRAINT ENGAGE HEIGHT" on page 22)



**Figure 5: Lag Locations**

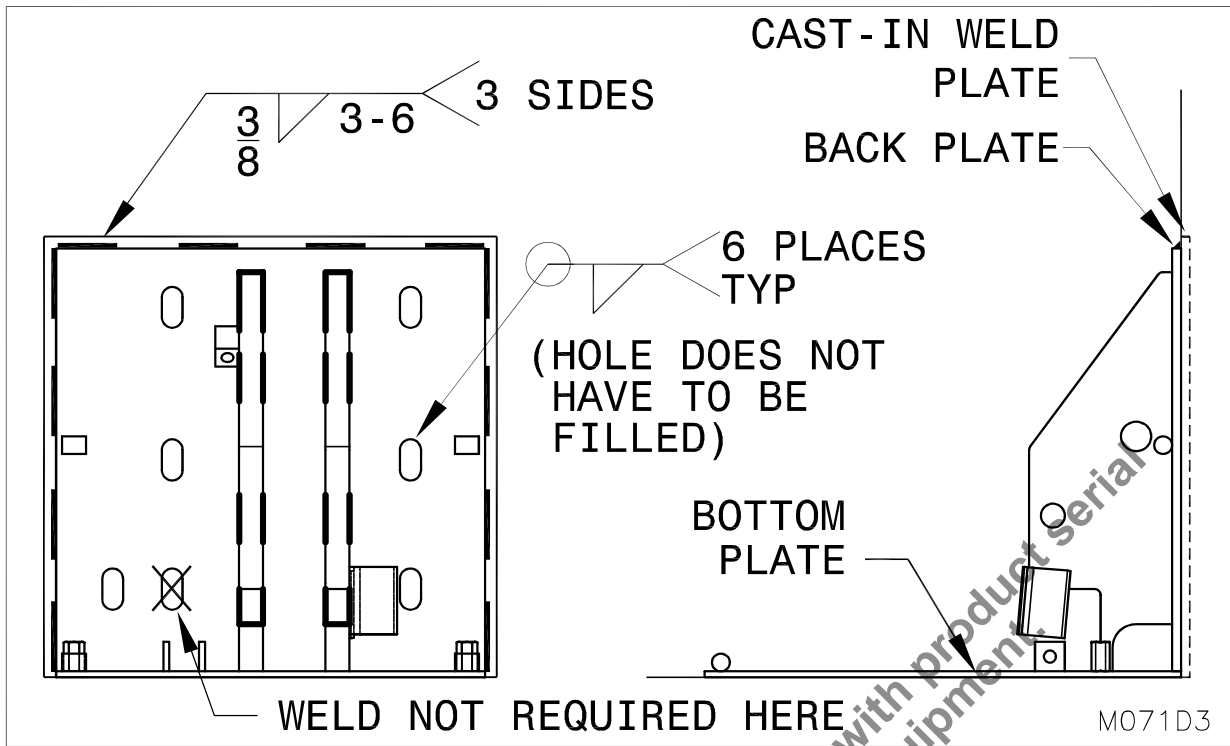

Figure 6: Weld Locations

### WELDING REFERENCE INFORMATION

- Observe and obey all welding safety requirements per AWS D1.1-92. (W117.2-74 in Canada.)
- Welding electrodes are to be clean and free from moisture.
- Material to be welded must be clean and free of oils, excessive millscale/rust etc.
- All craters are to be filled to a minimum of 85% of the cross sectional area of the weld.
- All under cutting is to be removed by either welding, grinding or a combination of both.
- Maximum reinforcement on butt welds is 1/8".
- Use highest current possible per chart below to obtain satisfactory weld.

| Electrode | E7018   |         |
|-----------|---------|---------|
| Diameter  | 1/8"    | 5/32"   |
| Amperage  | 130-150 | 140-180 |



**FAILURE TO PROPERLY INSTALL THE PENTALOCK MFRAL32 VEHICLE RESTRAINT MAY RESULT IN PROPERTY DAMAGE, BODILY INJURY OR DEATH AND WILL VOID ALL WARRANTIES.**

\_\_\_\_\_  
**Installer Name (Print)**

\_\_\_\_\_  
**Installer Signature**

\_\_\_\_\_  
**Date Installation Completed**

## OPTIONAL EXTENSION PLATE INSTALLATION INSTRUCTIONS



Before doing any installation, maintenance, inspection or trouble shooting, barricade all areas from traffic around the work area inside (and outside if applicable) for safety and post appropriate warning signs.



THIS RESTRAINT IS DESIGNED TO OPERATE WITH THE FACE OF THE DOCK BUMPERS EXTENDED 4" PAST THE POSITION OF THE BACK PLATE OF THE RESTRAINT ONCE IT IS INSTALLED. THIS DIMENSION RELATIONSHIP IS CRITICAL TO ASSURING THE PROPER OPERATIONAL POSITIONING OF THE RESTRAINT. THE OPTIONAL EXTENSION IS REQUIRED ONLY WHEN THIS RELATIONSHIP BETWEEN THE DOCK BUMPER AND THE RESTRAINT WILL NOT EXIST ONCE THE INSTALLATION IS COMPLETED. ONCE IT IS CONFIRMED THAT A RESTRAINT INSTALLATION EXTENSION PLATE IS REQUIRED, FOLLOW THESE INSTRUCTIONS TO INSTALL IT PROPERLY. (CONSULT YOUR AUTHORIZED PENTALIFT REPRESENTATIVE FOR ASSISTANCE IN ACQUIRING THE CORRECT EXTENSION)

1. Ensure concrete has sufficient strength to meet the draw pull forces which will be applied (See "Figure 2: Draw Pull Forces" on page 4).
2. Mark the centerline of the dock, the centerline of the restraint back plate and the centerline of the extension back plate vertically and horizontally between the mounting holes. If a weld plate has been pre-cast into the foundation, proceed to instruction #6.
3. Position the extension back plate by matching the centerline of the dock and the centerline of the plate. Drill the required holes into the foundation wall, using the extension back plate as a template.
4. If required, shim behind the extension back plate (as shown in "Figure 7: Shim Locations for Optional Extension" on page 7) to ensure the extension back plate is plumb and flush with the foundation wall.
5. Recommended fasteners are  $\frac{3}{4}$ " diameter x minimum 7" long wedge anchors with a minimum shear value of 18,500 lbs (8,390kg), and a tension value of 16,400 lbs (7,440 kg). Torque to manufacturers specifications.

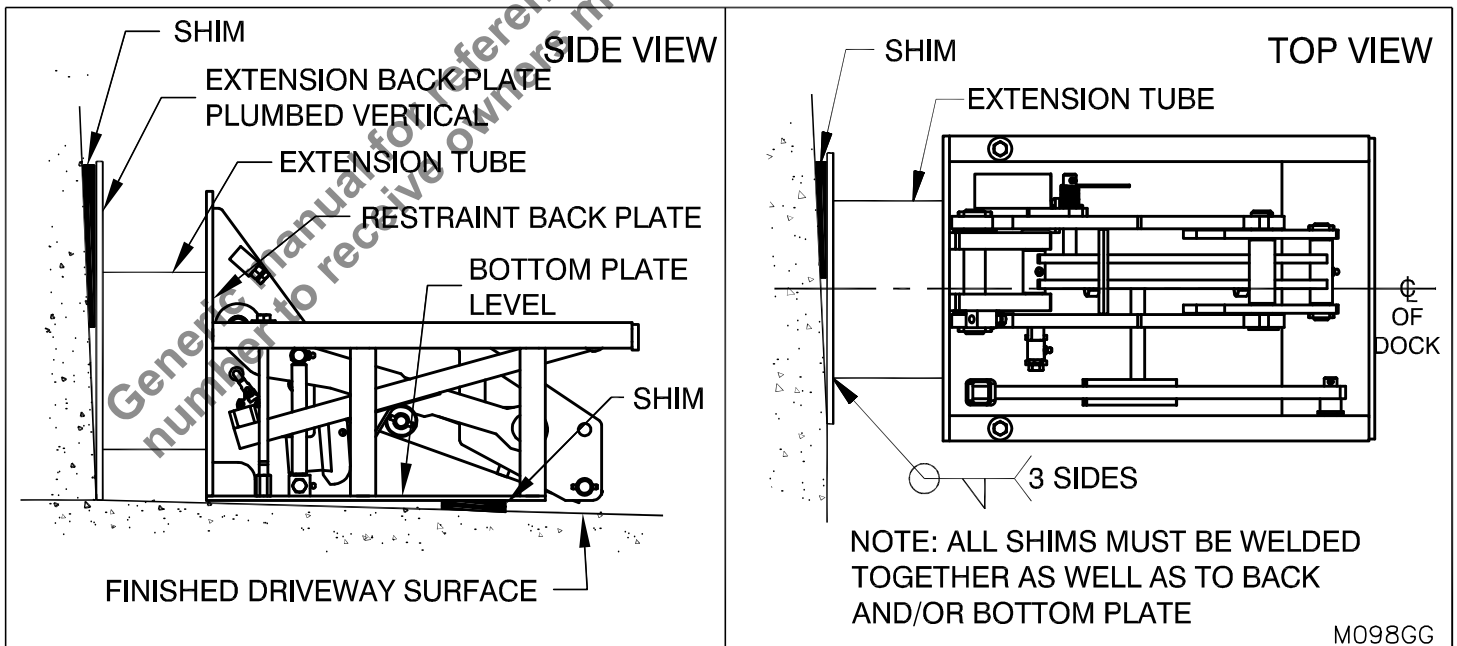
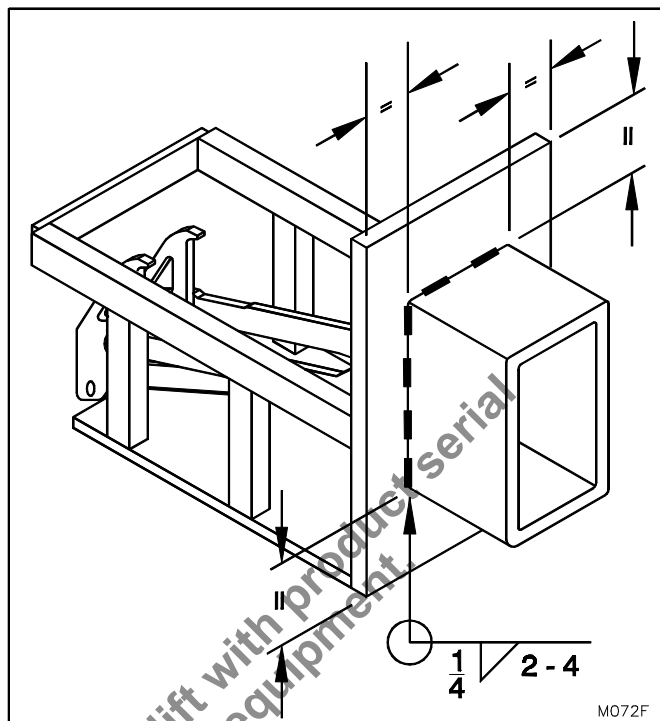

Figure 7: Shim Locations for Optional Extension

6.  Weld the extension tube to the restraint backplate, centered both vertically and horizontally between the mounting holes, as shown in "Figure 8: Optional Extension" on page 8, and weld using a minimum  $\frac{1}{4}$ " leg on the welds and 2" long welds on 4" centers. (Refer to the "WELDING REFERENCE INFORMATION" on page 6)
7.  Position the restraint, complete with extension tube, centered vertically and horizontally in front of the dock by matching the centerline of the dock and the centerline of the restraint back plate.
8.  If required, shim beneath the restraint as shown in "Figure 7: Shim Locations for Optional Extension" on page 7.
9.  Weld the extension tube to the extension back plate (or cast-in weld plate) using the same weld specifications as noted for welding the extension tube to the back plate of the restraint in "Figure 8: Optional Extension" on page 8.
10.  Weld all shims in a stack to each other as well as to the back plate and/or bottom plate.



**Figure 8: Optional Extension**

11.  Lubricate all pivot points (See "MAINTENANCE AND LUBRICATION" on page 20).
12.  Clean and paint welds using Tremclad High Performance Rust Enamel (Gloss Dark Machine Grey) if unit is not zinc coated. If unit is zinc coated, use Tremclad Gloss Aluminum Rust paint.
13.  Test operation (See "OPERATION AND PERFORMANCE CHECK" on page 13).
14.  Check the raised height of the restraint and ensure that it is properly set. If adjustment is required follow the adjustment instructions. (See "ADJUSTMENT OF RESTRAINT ENGAGE HEIGHT" on page 22).
15.  Confirm that all steps of the installation instructions have been completed. Fill out the following information.

\_\_\_\_\_  
**Installer Name (Print)**

\_\_\_\_\_  
**Installer Signature**

\_\_\_\_\_  
**Date Installation Completed**

# OPTIONAL HORIZONTAL (SURFACE) MOUNTED RESTRAINT INSTALLATION INSTRUCTIONS (MODEL MFRAL32SM)

If the intent is to surface mount the vehicle restraint on a horizontal surface (typically the loading dock driveway) without attaching it to the loading dock wall face, the first step is to confirm the restraint has been ordered and provided to accommodate surface mounting. Note the standard MFRAL32 is not suitable for surface mounting (without attachment to the loading dock wall face) and must be ordered and built optionally to the model MFRAL32SM to accommodate surface mounting. To confirm, review the vehicle restraint serial number plate. The model number should be indicated as MFRAL32SM. Also confirm the gussets, side lagging brackets and holes in the horizontal base plate are present as shown (see )



Before doing any installation, maintenance, inspection or trouble shooting, barricade all areas from traffic around the work area inside (and outside if applicable) for safety and post appropriate warning signs.



THIS RESTRAINT IS DESIGNED TO OPERATE WITH THE FACE OF THE DOCK BUMPERS EXTENDED 4" PAST THE POSITION OF THE BACK PLATE OF THE RESTRAINT ONCE IT IS INSTALLED. THIS DIMENSION RELATIONSHIP IS CRITICAL TO ENSURING THE PROPER OPERATIONAL POSITIONING OF THE RESTRAINT.

**Important note:** A horizontal surface mounting option creates the ability for the vehicle restraint to be installed on horizontal surface only without the requirement of being installed to a vertical support surface. This support surface is typically the driveway in front of the loading dock. The dimensional location of the vehicle restraint on the loading dock is critical in maximizing the restraints functionality and ability to properly restrain truck and trailers. When installing the vehicle restraint with surface mounting option, install the restraint so that it is centered laterally on the loading dock door and in a location from the dock face so that the back plate of the restraint is located 4" behind the face of the loading dock bumpers.

As well, confirm the installation surface in combination with the lag bolts (supplied by others) to be used for the installation has suitable strength to accept the forces as indicated in "Figure 9: Horizontal Surface Mounting Installation" on page 10. Note: Asphalt is typically not a suitable surface. Typically concrete of a sufficient depth and strength is required to accommodate the forces and loads as indicated.

If you are not certain in accommodating these requirements do not proceed with the installation.

1. \_\_\_ Inspect the MFRAL32SM. Confirm that the MFRAL32SM is configured for surface mounting. The optional horizontal surfacing mounting option consists of a series of holes in the bottom plate to accommodate the lagging as well as additional gusseting (see "Figure 9: Horizontal Surface Mounting Installation" on page 10)
2. \_\_\_ If there is damage to the restraint, rectify the damage by contacting the manufacturer. If there is no damage, proceed with the installation.
3. \_\_\_ Clean surface mounting area of all debris.
4. \_\_\_ Mark the center line of the dock leveler and the center line of the MFRAL32SM.
5. \_\_\_ Center the MFRAL32SM with the centerline of the dock leveler.
6. \_\_\_ Orient the restraint at the appropriate distance that places the back of the restraint 4" behind the front face of the loading dock bumper.
7. \_\_\_ Use a level to ensure that the MFRAL32SM is level side to side and front to back. Shimming may be required. All shims must be welded together and to the bottom of the MFRAL32SM. It is critical to ensure that the bottom of the MFRAL32SM make full contact with the supporting surface or grade especially underneath the gussets and hydraulic cylinder as indicated "Figure 9: Horizontal Surface Mounting Installation" on page 10. Make sure no voids exist under these areas.
8. \_\_\_ Lag the MFRAL32SM to the supporting surface using 3/4" diameter lag bolts (minimum shear force: 18,500 lbf; minimum tension value of 16,400 lbf). **Note: Lagging bolts are supplied by others. The lag bolt must provide the indicated tension and shear values. Follow the lag bolt manufacturer's instructions for installation as well as shear and tension values. Confirm the installation location is constructed to withstand the specified forces for the lag bolts. (see "Figure 9: Horizontal Surface Mounting Installation" on page 10)**

9.  Clean and paint welds using Tremclad High Performance Rust Enamel (Gloss Dark Machine Grey) if unit is not zinc coated. If unit is zinc coated, use Tremclad Gloss Aluminum Rust paint.
10.  Confirm that all steps of the installation instructions have been completed. Fill out the following information.

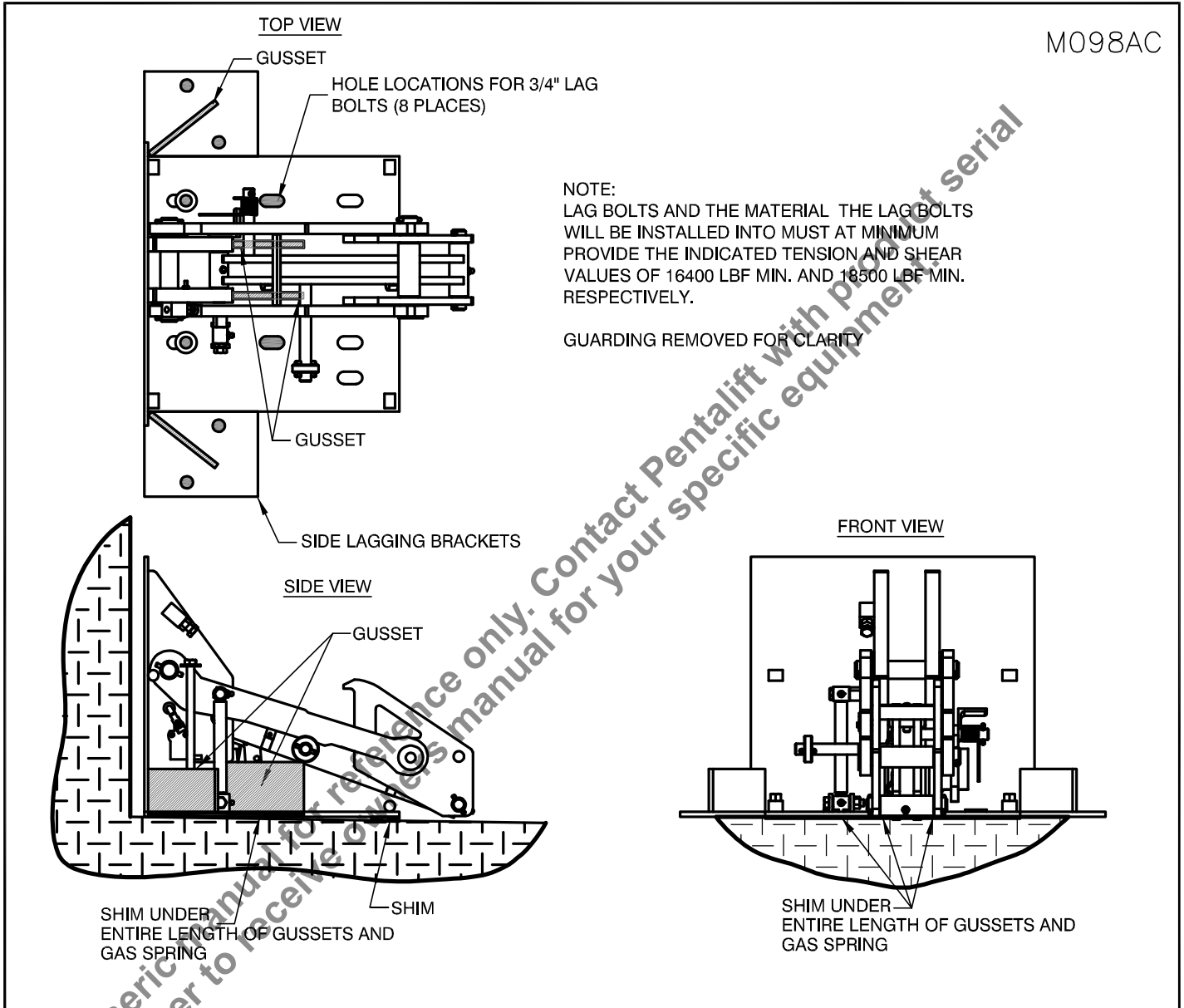

**Figure 9: Horizontal Surface Mounting Installation**

\_\_\_\_\_  
**Installer Name (Print)**

\_\_\_\_\_  
**Installer Signature**

\_\_\_\_\_  
**Date Installation Completed**

# ELECTRICAL INSTALLATION INSTRUCTIONS



Before doing any installation, maintenance, inspection or trouble shooting, barricade all areas from traffic around the work area inside (and outside if applicable) for safety and post appropriate warning signs.



- WIRING MUST BE DONE BY A QUALIFIED ELECTRICIAN.
- ALWAYS USE APPROPRIATE LOCK-OUT PROCEDURES DURING ANY ELECTRICAL INSTALLATIONS.
- ENSURE SUPPLY VOLTAGE IS CORRECT.
- ALWAYS OBSERVE ALL APPLICABLE ELECTRICAL CODES.



Arc flash and shock hazard PPE (personal protection equipment) required. De-energize equipment before working on or inside. Do not open cover without appropriate PPE. Refer to NFPA 70E for PPE requirements. This panel may contain more than one power source. Hazardous voltage will cause severe injury or death.



Before doing any electrical work, be certain that the power is disconnected with a fused disconnect, properly tagged and locked out. Fused disconnect and lockout device (supplied and installed by others) must meet with all applicable codes and regulations. All electrical work must be performed by a qualified electrician in accordance with all applicable codes and regulations.

The following instructions apply to standard units:

1. \_\_\_ Ensure an electrical conduit is in place to bring the signal light control panel wiring from inside to the signal light outside.
2. \_\_\_ Install the control panel and interior warning sign, "Enter on Green Only", in a location that ensures complete legibility of the operating instructions during the operation of all loading dock equipment, including the forklifts.
3. \_\_\_ Mount outside light set approximately 90" high from the center of the light to the finished driveway level (see "Figure 10: Light, Sign and Conduit Locations" on page 12).
4. \_\_\_ Mount the mirror image "Caution" sign above the outside light and the normal vision "Caution" sign below the outside light.
5. \_\_\_ Connect all electrical lines as per the wiring diagram inside the electrical control panel.
6. \_\_\_ Test operation (see "OPERATION AND PERFORMANCE CHECK" on page 13).
7. \_\_\_ Check the raised height of the restraint and ensure that it is properly set. If adjustment is required follow the adjustment instructions. (See "ADJUSTMENT OF RESTRAINT ENGAGE HEIGHT" on page 22).
8. \_\_\_ Fully raise and lower the unit a minimum of 10 times and check the performance of the stored limit switch and lights to ensure correct operation. (See "OPERATION AND PERFORMANCE CHECK" on page 13)
9. \_\_\_ Confirm that all steps of the installation instructions have been completed. Fill out the following information.

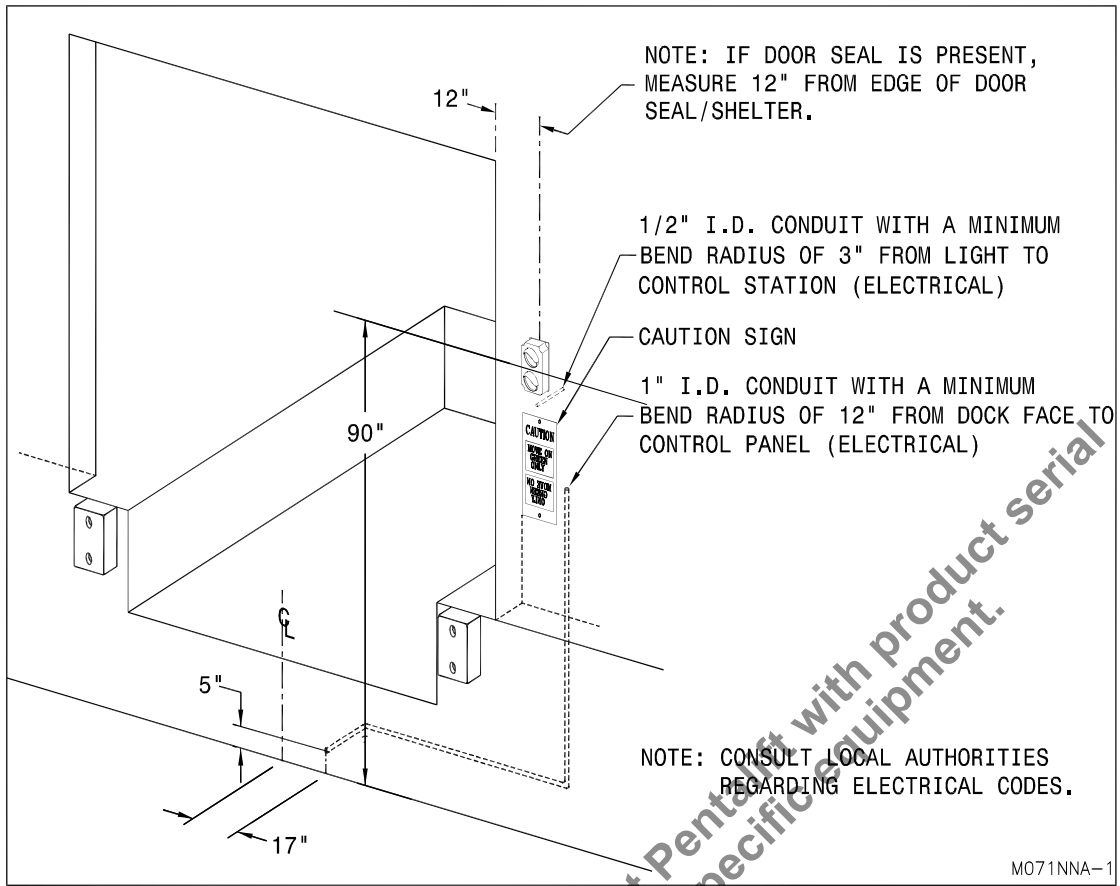

Figure 10: Light, Sign and Conduit Locations

\_\_\_\_\_  
 Installer Name (Print)

\_\_\_\_\_  
 Installer Signature

\_\_\_\_\_  
 Date Installation Completed

**⚠ DANGER**

FAILURE TO PROPERLY INSTALL THE MFRAL32 MAY RESULT IN PROPERTY DAMAGE, BODILY INJURY OR DEATH AND WILL VOID ALL WARRANTIES.

## OPERATION AND PERFORMANCE CHECK



Before doing any installation, maintenance, inspection or trouble shooting, barricade all areas from traffic around the work area inside (and outside if applicable) for safety and post appropriate warning signs.



Arc flash and shock hazard PPE (personal protection equipment) required. De-energize equipment before working on or inside. Do not open cover without appropriate PPE. Refer to NFPA 70E for PPE requirements. This panel may contain more than one power source. Hazardous voltage will cause severe injury or death.



Before doing any electrical work, be certain that the power is disconnected with a fused disconnect, properly tagged and locked out. Fused disconnect and lockout device (supplied and installed by others) must meet with all applicable codes and regulations. All electrical work must be performed by a qualified electrician in accordance with all applicable codes and regulations.



**FAILURE TO CONFIRM THE CORRECT OPERATION OF THE VEHICLE RESTRAINT IN ACCORDANCE WITH THESE INSTRUCTIONS MAY RESULT IN PROPERTY DAMAGE, BODILY INJURY OR DEATH.**

**NOTE:** A very high level of field issues with this type of equipment can be directly attributed to improper or incomplete installation. The installation instructions and information provided for this equipment is thorough. A step by step sequence for installation is provided. All steps must be followed and completed to provide a complete installation. Incomplete or improper installations can lead to equipment malfunction and / or damage, create safety issues and void warranties. Please follow all installation and set ups steps as indicated in the installation instructions and owner's manual. If you are unclear or uncertain regarding any of the steps contact your Pentlift representative for clarification. A copy of the completed steps listing with the sign off and photos of the installation as indicated at the conclusion of the installation instructions will be required prior to any Pentlift factory trouble shooting assistance.



**Regarding use with Vertical Storing Dock levelers:**

In order to manually engage or disengage the vehicle restraint using the vehicle restraint push bar the operator must enter the operating path of the vertical storing dock leveler. To prevent possible injury, it is imperative that prior to entering the operating path of the vertical storing dock leveler for any reason, including for the purpose of activating or storing the MFR restraint, that the operator confirms that the vertical storing dock leveler maintenance stand has been engaged. Once the vehicle restraint has been operated, confirm that the vertical storing dock leveler maintenance stand has been disengaged before attempting to operate the vertical storing dock leveler.

**NOTE: IN SOME CASES THERE IS A CONSIDERABLE AMOUNT OF TIME BETWEEN THE SHIPMENT DATE AND USE OF YOUR VEHICLE RESTRAINT. THIS INITIAL BREAK-IN AND PERFORMANCE CHECK SHOULD BE PERFORMED BEFORE YOU BEGIN REGULAR USE OF YOUR VEHICLE RESTRAINT TO ENSURE THAT IT IS OPERATING PROPERLY.**

1. Confirm stored limit switch is set up and adjusted properly (see "Figure 24: Adjusting the Stored Limit Switch" on page 26).
2. Confirm restraint engage height adjust as instructed in "ADJUSTMENT OF RESTRAINT ENGAGE HEIGHT" on page 22
3. Ensure the vehicle restraint has been returned to the fully stored position and that the latch securely engages to maintain the vertical lock arm in the stored position (See "Figure 13: Restraint Stored - Push Latch to Release" on page 16)
4. Turn the 3-position selector switch to "AUTO". The red light on the control panel and the green outside light must be illuminated.

5. Use the operating "T" handle to push firmly on the top of the latch. This releases the restraint from the stored position and allows the gas spring system to raise the vertical lock arm with an upward bias (see "Figure 13: Restraint Stored - Push Latch to Release" on page 16).
6. The outside light must illuminate red and the inside control panel light must illuminate green while the vertical lock arm is raised and the signal stored switch is not depressed.
7. Place the operating "T" handle into the locating detent on the push down arm. Push firmly on the handle to return the restraint to the fully stored position (see "Figure 21: Restraint Raised-Push Arm to Release Vehicle / Return to Stored Position" on page 19). To facilitate easiest lowering, push and continue to push with one continuous effort until the restraint latches in the stored position. The latch must hook under the catch to hold the restraint in the fully stored position (see "Figure 13: Restraint Stored - Push Latch to Release" on page 16).
8. Confirm outside **GREEN** light is illuminated with outside **RED** light off. Confirm inside **RED** light is illuminated with inside **GREEN** light off.
9. Turn the selector switch to "**G/R**". The green outside light and the red light on the control panel must be illuminated. (The green light on the control panel and the red outside light must not be illuminated.)
10. Turn the selector switch to "**R/G**". The outside red light and the green light on the control panel must be illuminated. (The red light on the control panel and the outside green light must not be illuminated.)
11. Return the switch to the "**AUTO**" position.
12. Return the restraint to the stored position.
13. Replace burnt out light bulbs on the control panel, or defective LED modules, immediately.

The above steps describe and confirm the correct operation of this important piece of safety equipment. If the unit you have does not meet the requirements listed above, discontinue its use and/or repair it immediately. See the Troubleshooting section to correct problems. Contact your Pentalift representative for any required assistance.

Generic manual for reference only. Contact Pentalift with product serial number to receive owners manual for your specific equipment.

# OPERATING INSTRUCTIONS



Use by untrained people can result in property damage, bodily injury or death. Read, know, and obey all operating instructions and safety information. Follow all OSHA regulations regarding the use of this equipment. Do not use the vehicle restraint if any part of it looks broken or if it does not seem to operate properly. If repairs are needed, contact your pentlift representative.

**NOTE:** It is common for this product to be supplied in combination with other Pentlift Products. When the product supplied with other Pentlift products it is quite common for a combination control panel to be provided. The combination control panel will be a single control panel from which more than one product will be controlled and operated. If your installation incorporates the use of such a common control panel then read and follow all the instructions on the panel. If the instructions on the control panel conflict with instructions in this manual then follow the instructions on the control panel.

## VEHICLE RESTRAINT STORED/DOCK EMPTY

1. Ensure the vehicle restraint is in the stored position and the selector switch is in the "AUTO" position. The outside green light is illuminated, indicating to drivers that it is safe to approach the dock. The inside red light on the control panel is illuminated, indicating to personnel that it is unsafe to load/unload the trailer/vehicle.



Regarding use with Vertical Storing Dock levelers:

In order to manually engage or disengage the vehicle restraint using the vehicle restraint push bar the operator must enter the operating path of the vertical storing dock leveler. To prevent possible injury, it is imperative that prior to entering the operating path of the vertical storing dock leveler for any reason, including for the purpose of activating or storing the MFR restraint, that the operator confirms that the vertical storing dock leveler maintenance stand has been engaged. Once the vehicle restraint has been operated, confirm that the vertical storing dock leveler maintenance stand has been disengaged before attempting to operate the vertical storing dock leveler.

## TRAILER IN POSITION

2. With the truck/trailer in position, centered in front of the loading dock and parked tight against both dock bumpers, use the operating "T" handle to push firmly on the top of the latch. This releases the restraint from the stored position and allows the gas spring system to raise the vertical lock arm with an upward bias (see "Figure 13: Restraint Stored - Push Latch to Release" on page 16).



THE TOP OF THE R.I.G. OF THE TRUCK/TRAILER MUST ALWAYS BE LOWER THAN THE OVERHANG ON THE FRONT FACE OF THE VERTICAL LOCK ARM AND LOCATED BETWEEN THE FRONT FACE OF THE VERTICAL LOCK ARM AND THE RESTRAINT BACK PLATE (See "Figure 15: Vertical Locking Arm Position" on page 17). IF THE TRUCK/TRAILER IS NOT PROPERLY ENGAGED AS PER THESE INSTRUCTIONS, LOWER THE RESTRAINT (See "What to do if the R.I.G CANNOT BE ENGAGED BY the RESTRAINT" on page 19) AND DO NOT LOAD/UNLOAD UNTIL THE TRAILER IS SECURED BY OTHER MEANS. See "Figure 20: Secure Trailer by Other Means" on page 19.

3. Visually confirm that the restraint has properly engaged the rear impact guard (see "Figure 15: Vertical Locking Arm Position" on page 17, before loading or unloading. If unable to properly engage the vehicle with the restraint, lower the restraint to the stored position and use other suitable means must be used to restrain the vehicle, then use manual light mode to illuminate RED outside and GREEN inside lights.
4. With the Rear Impact Guard properly secured and visually confirmed, also confirm the illumination of the lights have reversed. Visually confirm the control panel green light and outside red light have illuminated.
5. Loading/unloading may commence.

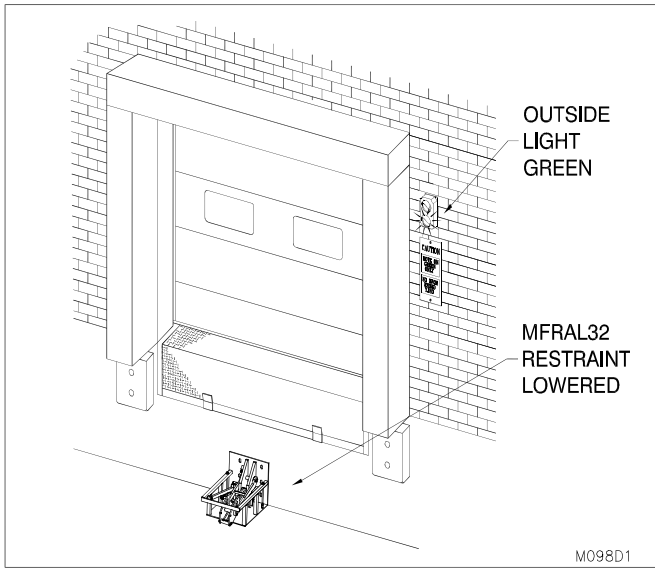

**Figure 12: Dock Ready to Receive Vehicle**

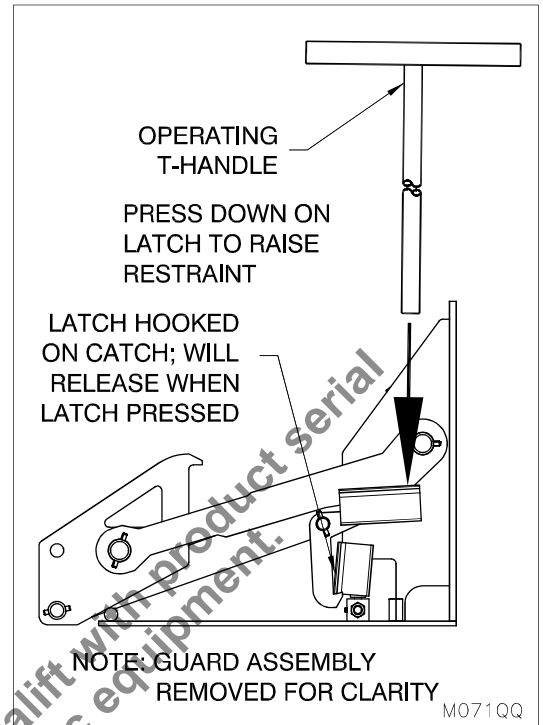

**Figure 13: Restraint Stored - Push Latch to Release**

Generic manual for reference only. Contact Pentalift with product serial number to receive owners manual for your specific equipment.

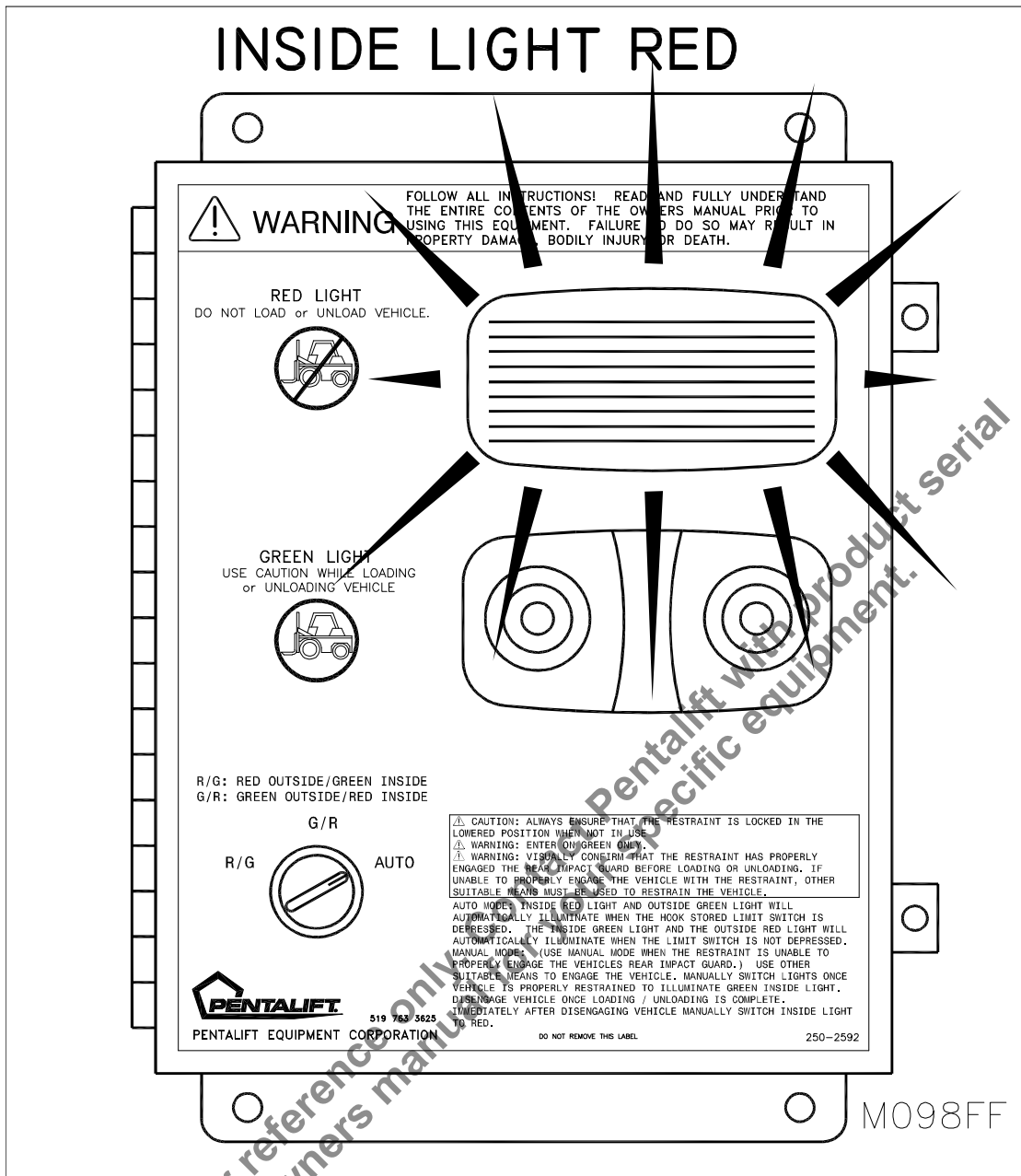

Figure 14: Set Selector Switch to "AUTO" When Ready to Receive a Vehicle

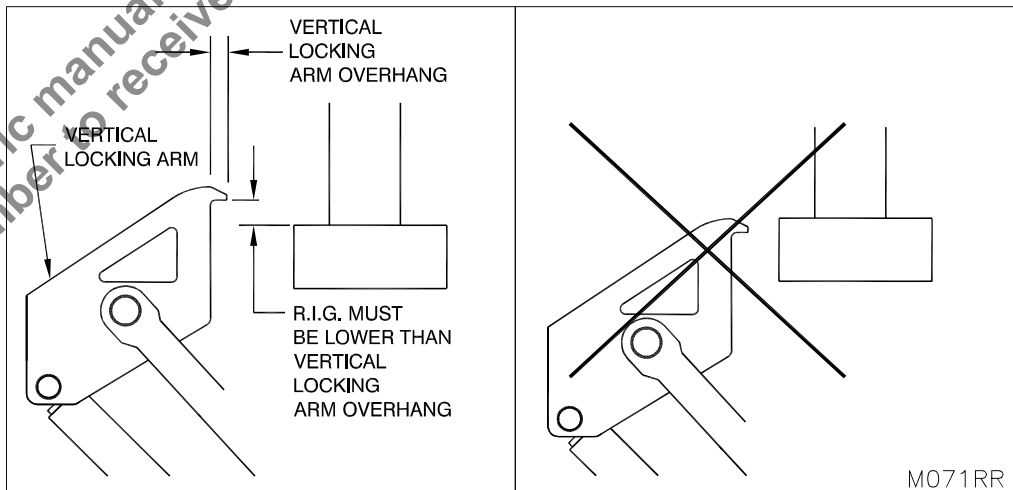

Figure 15: Vertical Locking Arm Position

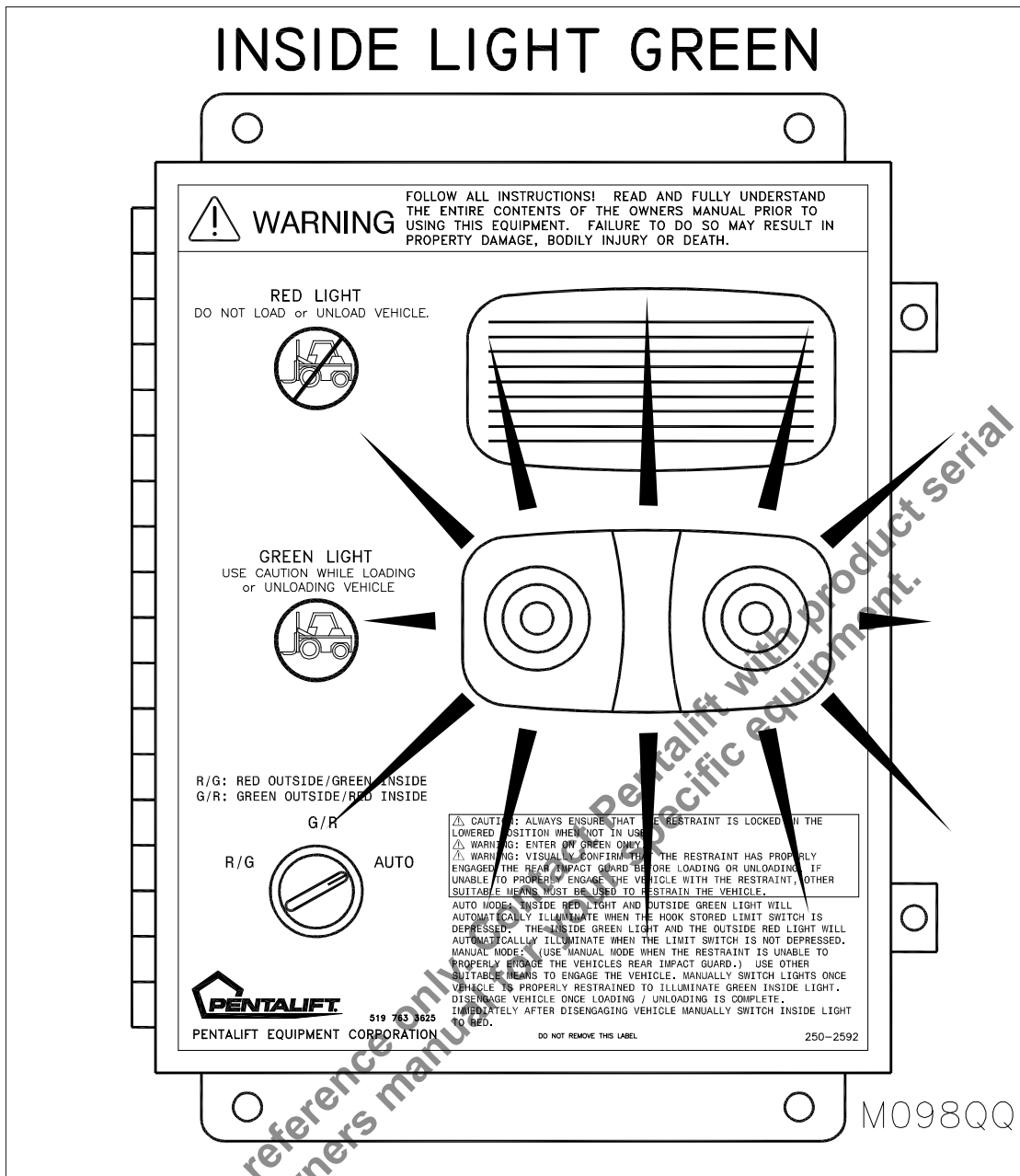

Figure 16: Inside Light Green When Selector Switch Set to "AUTO"

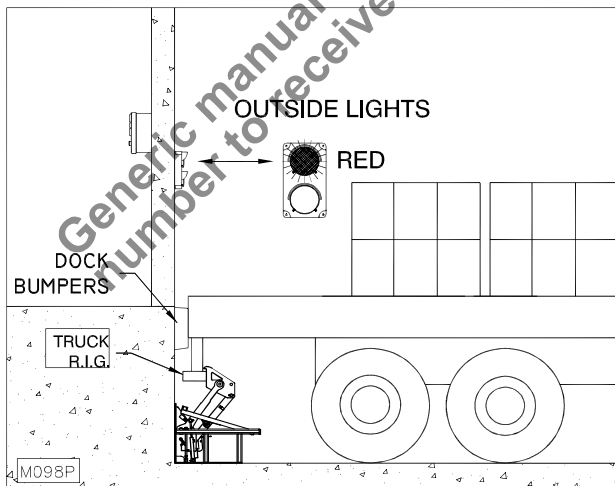

Figure 17: Vehicle Secure

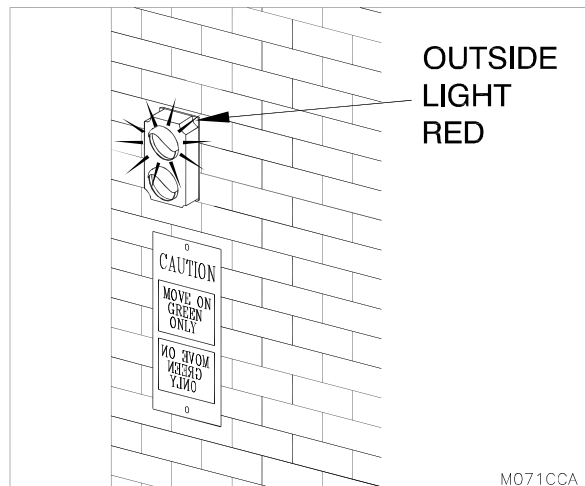
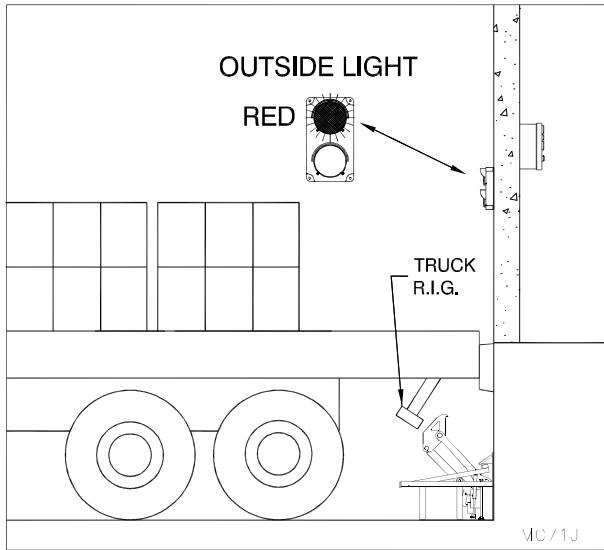
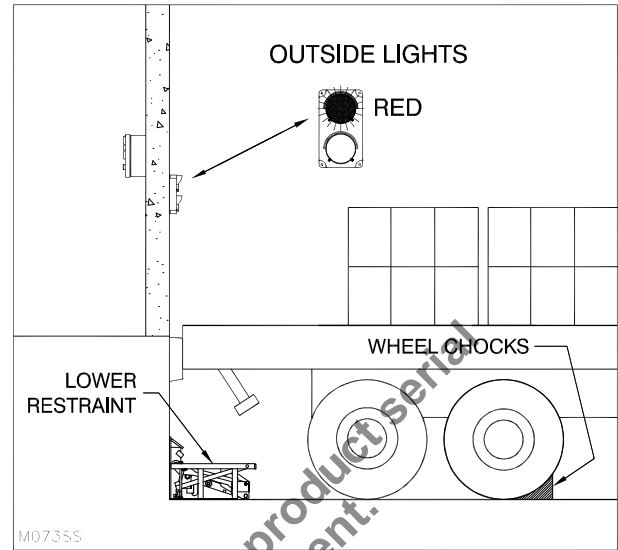

Figure 18: Driver Signal

# WHAT TO DO IF THE R.I.G CANNOT BE ENGAGED BY THE RESTRAINT



**Figure 19: R.I.G. Not Secure**



**Figure 20: Secure Trailer by Other Means**

- Confirm that the vehicle has been restrained by other suitable means before loading or unloading. NOTE: Wheel chocks are other suitable means.
- Turn the selector switch to the "R/G" position. Inside green light and outside red light will be illuminated.
- Return the restraint to the stored position.
- Loading/unloading may commence.

## LOADING / UNLOADING COMPLETE

- If restraint is engaged and selector switch is in the "AUTO" position, place the operating "T" handle into the locating tube on the push down arm. Push firmly on the handle to return the restraint to the fully stored position (see "Figure 21: Restraint Raised-Push Arm to Release Vehicle / Return to Stored Position" on page 19). To facilitate easiest lowering, push and continue to push with one continuous effort until the restraint latches in the stored position. The latch must hook under the catch to hold the restraint in the fully stored position (See "Figure 13: Restraint Stored - Push Latch to Release" on page 16). Illumination of the lights will reverse (inside red and outside green will be illuminated.) The truck is free to depart and the dock is ready to receive another truck.

If the trailer was secured by other means, remove them at this time. Immediately turn the selector switch to the "G/R" Position. Illumination of the lights will reverse (inside red and outside green will be illuminated.) The truck is free to depart and the dock is ready to receive another truck. All loading/unloading must be discontinued.

NOTE: If the vehicle R.I.G. has moved forward during loading / unloading (truck "creep" has occurred), there may be draw pull force and friction holding the restraint in in the engaged position. If the restraint will not release, move the trailer back toward the dock to release the tension on the restraint, allowing it to lower.

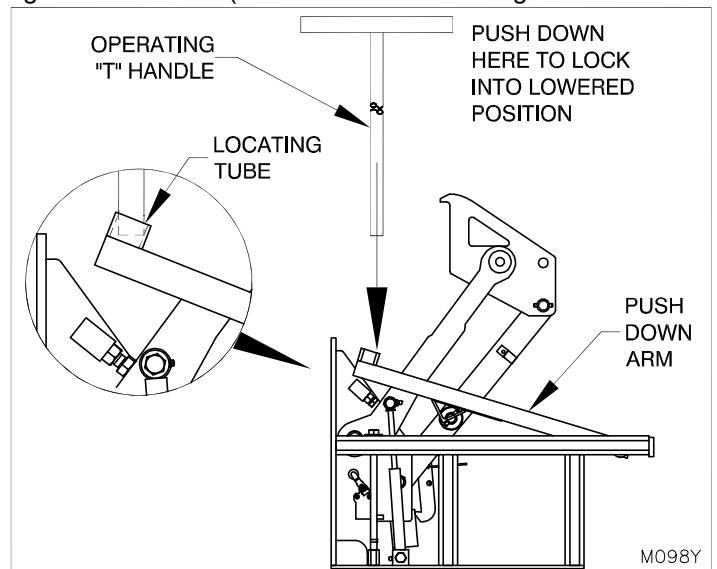

**Figure 21: Restraint Raised-Push Arm to Release Vehicle / Return to Stored Position**

# MAINTENANCE AND LUBRICATION



ONLY TRAINED AND QUALIFIED PERSONNEL SHOULD PERFORM INSPECTION OR MAINTENANCE AND SERVICE PROCEDURES.



Before doing any installation, maintenance, inspection or trouble shooting, barricade all areas from traffic around the work area inside (and outside if applicable) for safety and post appropriate warning signs.



Arc flash and shock hazard PPE (personal protection equipment) required. De-energize equipment before working on or inside. Do not open cover without appropriate PPE. Refer to NFPA 70E for PPE requirements. This panel may contain more than one power source. Hazardous voltage will cause severe injury or death.



Before doing any electrical work, be certain that the power is disconnected with a fused disconnect, properly tagged and locked out. Fused disconnect and lockout device (supplied and installed by others) must meet with all applicable codes and regulations. All electrical work must be performed by a qualified electrician in accordance with all applicable codes and regulations.

**NOTE:** A very high level of field issues with this type of equipment can be directly attributed to improper or incomplete installation. The installation instructions and information provided for this equipment is thorough. A step by step sequence for installation is provided. All steps must be followed and completed to provide a complete installation. Incomplete or improper installations can lead to equipment malfunction and / or damage, create safety issues and void warranties. Please follow all installation and set ups steps as indicated in the installation instructions and owner's manual. If you are unclear or uncertain regarding any of the steps contact your Pentalift representative for clarification. A copy of the completed steps listing with the sign off and photos of the installation as indicated at the conclusion of the installation instructions will be required prior to any Pentalift factory trouble shooting assistance.

**CLEANING:** The face of a loading dock is generally one of the dirtiest areas in a facility. Dirt and debris fall from the loading dock into and on the restraint area. The **MFRAL32 Vehicle Restraint** is designed to have a long trouble free operating life in this type of condition. However, the area around the restraint must be cleaned on a regular basis. Frequency will vary depending on the conditions at each individual location. Initially, cleaning must be done on a weekly basis. Thereafter, the frequency of cleaning can be adjusted to suit the specific individual installation conditions. Snow and ice must be cleaned away as soon as it accumulates.

**CHECK ON A DAILY BASIS:** Conduct the steps listed in the OPERATION AND PERFORMANCE CHECK Section of this manual. (See page 13). Check the raised height of the restraint and ensure that it is properly set. If adjustment is required, follow the adjustment instructions. (See "ADJUSTMENT OF RESTRAINT ENGAGE HEIGHT" on page 22)

**NOTE:** Read the **SAFETY INFORMATION AND WARNINGS** before servicing the **MFRAL32 Vehicle Restraint**. (See page II.)

**NOTE:** It is the owner's responsibility to ensure that all labeling remains legible and in its original position throughout the life of the product (See "PRECAUTIONARY LABELING" on page 2).

**NOTE:** Inspect equipment for protective coatings (i.e. paint) that have deteriorated or been removed. Prepare affected area and reapply protective coating as required using Tremclad High Performance Rust Enamel (Gloss Dark Machine Grey) if zinc coating not used.

**NOTE:** At every maintenance interval, inspect the **MFRAL32 Vehicle Restraint** for any damaged or worn parts. If any damaged or worn parts are found, discontinue use of the vehicle restraint and/or repair immediately.

**NOTE:** At every maintenance/lubrication interval, check that the signal bar spring is in place and that the spring retaining bolt is tight against signal bar spring, ensure bolt is secured with jam nut.

**LUBRICATION:**

As shown by “Figure 22: Lubrication Points” on page 21, four pivot points on the Vehicle Restraint must be lubricated regularly to help maintain the unit in proper working condition. The recommended lubrication **service interval is every 30 days** or at a greater frequency as required in severe environments. For maximum bearing life, the recommended **lubricant is NLGI Grade 2 grease with EP and MOS2 additives**. Oil all pivot points without grease fittings. **Dexron III Automatic Transmission Fluid is recommended.**

Replace burnt out light bulbs on the control panel, or defective LED modules, immediately. Due to the continuous duty of dock traffic light systems and the life span of light bulbs, daily inspection of the light system should be performed. Spare light bulbs and an LED module should be kept on hand at all times for immediate replacement. Ensure that the proper lens color is in the proper position after checking bulbs and LED modules. **USE ONLY GENUINE PENTALIFT REPLACEMENT PARTS.**

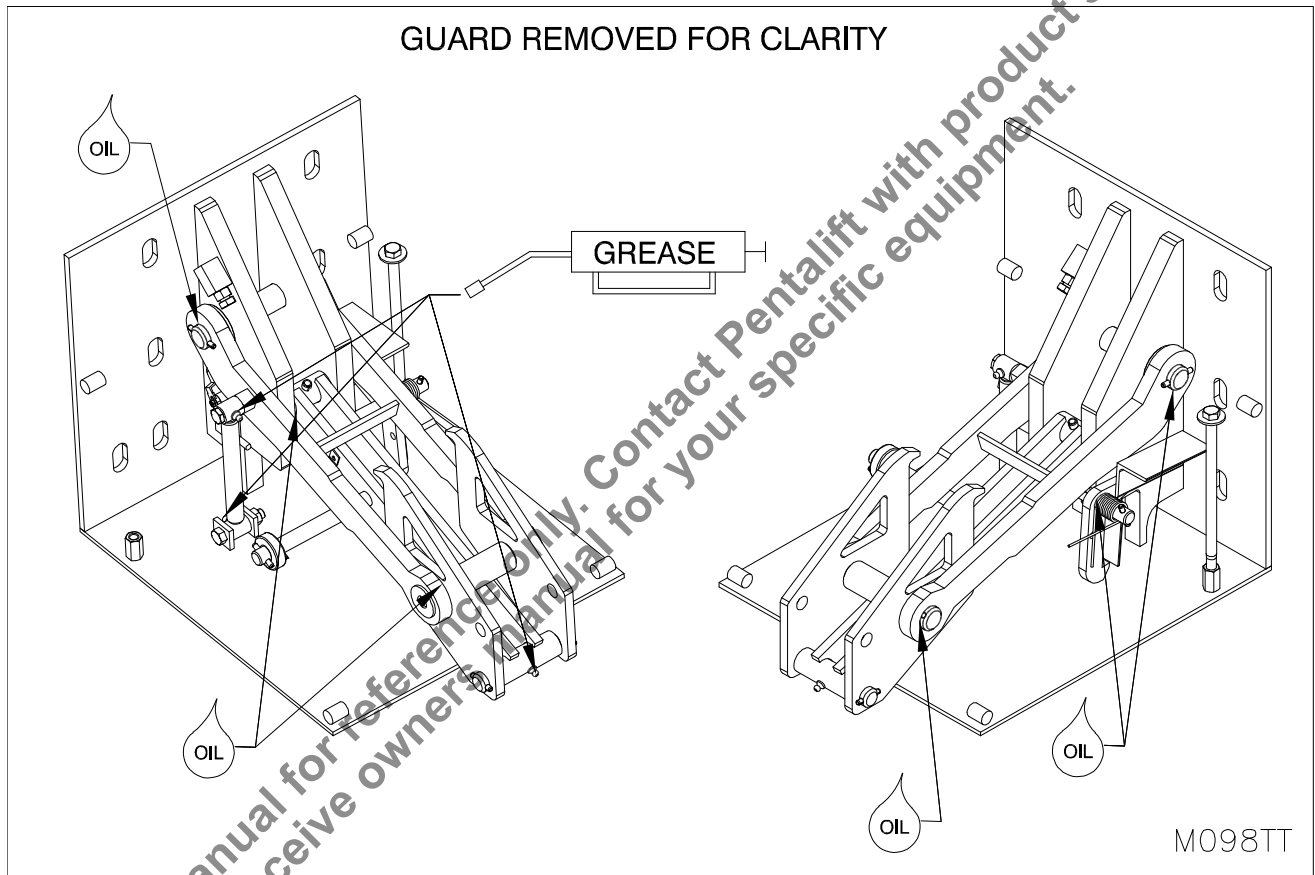

**Figure 22: Lubrication Points**

## ADJUSTMENT OF RESTRAINT ENGAGE HEIGHT

**NOTE: THE OPTIMAL RAISED HEIGHT IS PRESET AT THE FACTORY AND SHOULD NOT REQUIRE ADJUSTMENT.**

If adjustment is required, proceed with the following steps.

**IF RAISED HEIGHT IS TOO LOW:** Loosen stop block locking nut. Turn adjustment bolt **in** to **increase** raised height up to the maximum raised height. When proper height is achieved, tighten lock nut against the adjustable stop block. (See "Figure 23: Raised Height Adjustment" on page 22)

**IF RAISED HEIGHT IS TOO HIGH:** Loosen stop block locking nut. Turn adjustment bolt **out** to **decrease** raised height. When proper height is achieved, tighten lock nut against the adjustable stop block. (See "Figure 23: Raised Height Adjustment" on page 22)

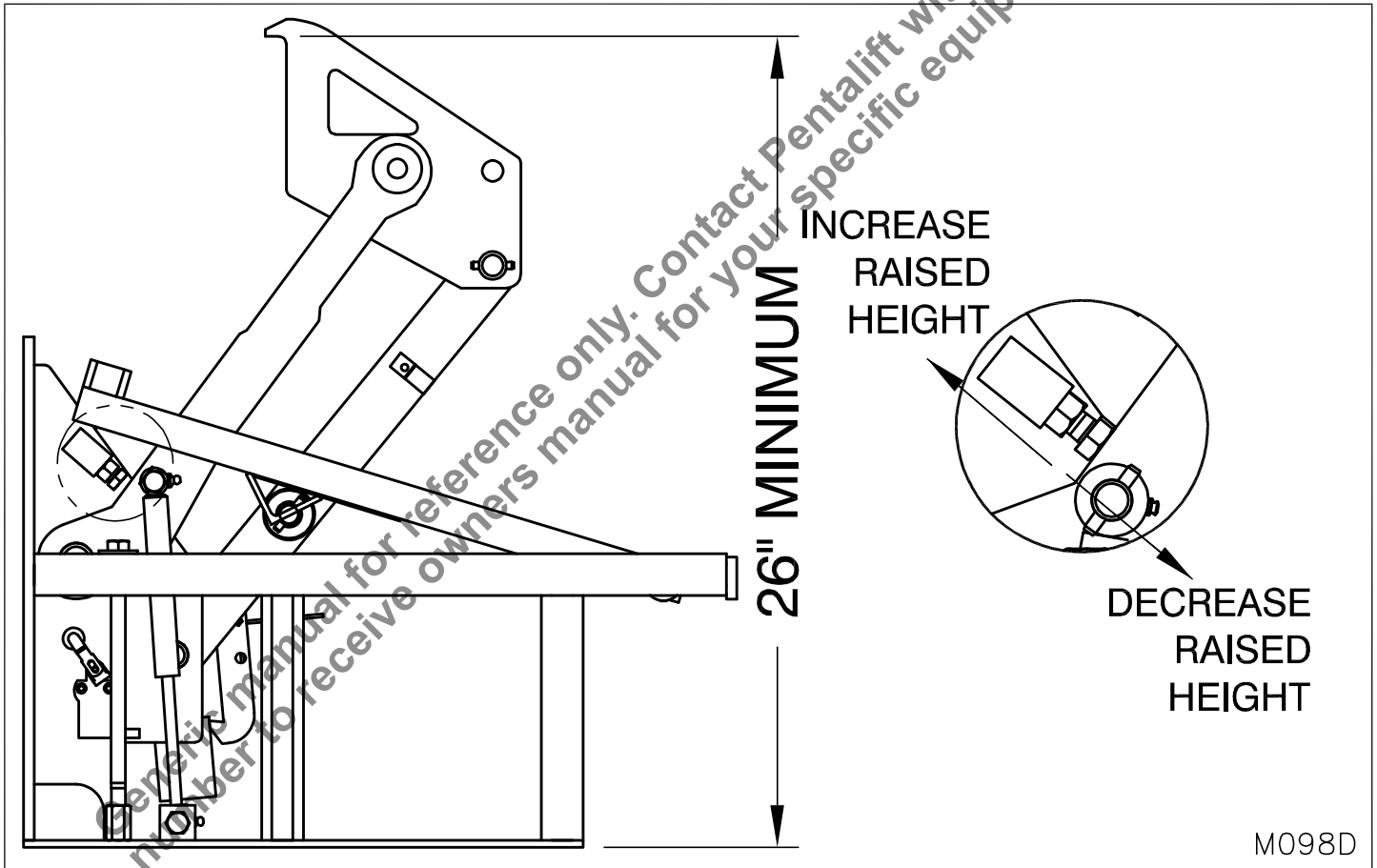

Figure 23: Raised Height Adjustment

# TROUBLE SHOOTING GUIDE

**NOTE:** This equipment has been fully tested and confirmed to be operational at the factory. Historically, the majority of operating problems are caused by unnecessary tampering by unqualified personnel. To conform to the terms of the Warranty, contact your authorized Pentalift representative if you are having any difficulty with the restraint during the warranty period. Do not risk voiding the warranty by tampering with the equipment.

**⚠ DANGER** ONLY TRAINED AND QUALIFIED PERSONNEL SHOULD PERFORM INSPECTION OR MAINTENANCE AND SERVICE PROCEDURES.

**⚠ DANGER** Before doing any installation, maintenance, inspection or trouble shooting, barricade all areas from traffic around the work area inside (and outside if applicable) for safety and post appropriate warning signs.

**⚠ DANGER** Before doing any electrical work, be certain that the power is disconnected with a fused disconnect, properly tagged and locked out. Fused disconnect and lockout device (supplied and installed by others) must meet with all applicable codes and regulations. All electrical work must be performed by a qualified electrician in accordance with all applicable codes and regulations.

**⚠ DANGER** Arc flash and shock hazard PPE (personal protection equipment) required. De-energize equipment before working on or inside. Do not open cover without appropriate PPE. Refer to NFPA 70E for PPE requirements. This panel may contain more than one power source. Hazardous voltage will cause severe injury or death.

**NOTE:** A very high level of field issues with this type of equipment can be directly attributed to improper or incomplete installation. The installation instructions and information provided for this equipment is thorough. A step by step sequence for installation is provided. All steps must be followed and completed to provide a complete installation. Incomplete or improper installations can lead to equipment malfunction and / or damage, create safety issues and void warranties. Please follow all installation and set ups steps as indicated in the installation instructions and owner's manual. If you are unclear or uncertain regarding any of the steps contact your Pentalift representative for clarification. A copy of the completed steps listing with the sign off and photos of the installation as indicated at the conclusion of the installation instructions will be required prior to any Pentalift factory trouble shooting assistance.

## 1. Restraint will not rise completely:

- Check for any obstructions or binding to ensure the hook can move freely.
- Confirm restraint is properly lubricated. (See "Figure 22: Lubrication Points" on page 21)
- Check to see that the truck has backed up tight against the dock bumpers.
- Check that the latch is properly releasing from the catch.
- Confirm the gas springs are providing sufficient force to raise the restraint. (See "OPERATION AND PERFORMANCE CHECK" on page 13). **NOTE:** The colder the environment, the less force the gas spring will provide.
- If the problem cannot be solved, consult your authorized Pentalift representative.

## 2. Restraint will not lower:

- Check for any obstructions or binding to ensure the hook can move freely.
- Check that the vertical lock arm is not caught on the R.I.G. of the truck. **NOTE:** If the vehicle R.I.G. has moved forward during loading / unloading (truck "creep" has occurred), there may be draw pull force and friction holding the restraint in the engaged position. If the restraint will not release, move the trailer back toward the dock to release the tension on the restraint.
- If the problem cannot be solved, contact your authorized Pentalift Representative.

## 3. Restraint lowers but will not stay stored:

- Check for any obstructions or binding to ensure the hook can move freely.
- Ensure that the latch is properly engaging the catch.
- If the problem cannot be solved, contact your authorized Pentalift Representative.

**4. Restraint will rise, but inside and/or outside lights will not illuminate:**

- a. Check that the power supply to the unit is connected properly.
- b. Check primary fuse.
- c. Check for appropriate incoming voltage to the control panel.
- d. Check all wiring.
- e. Check the stored limit switch is functional, adjusted properly (see "RESTRAINT ADJUSTMENTS" on page 25) and wired correctly
- f. Confirm that the control panel light bulbs are not loose or burnt out.
- g. Confirm that the exterior light LED modules are not burnt out.
- h. If the problem cannot be solved, contact your authorized Pentalift Representative.

**5. Illumination of lights will not reverse when the selector switch is turned:**

- a. Confirm the selector switch is functioning properly.
- b. Check wiring.
- c. If the problem cannot be solved, contact your authorized Pentalift Representative.

If damaged or worn parts are detected upon inspection, replacement must be undertaken immediately. **The vehicle restraint must not be used until replacement is completed.** Parts are readily available from your Pentalift representative.

Generic manual for reference only. Contact Pentalift with product serial number to receive owners manual for your specific equipment.

## RESTRAINT ADJUSTMENTS



TO ENSURE THAT THE RESTRAINT IS NOT INADVERTANTLY ACTIVATED WHILE THE FOLLOWING ADJUSTMENTS ARE BEING MADE, BARRICADE ALL AREAS FROM TRAFFIC AROUND THE WORK AREA INSIDE (AND OUTSIDE IF APPLICABLE) FOR SAFETY (PARTICULARLY THE CONTROL BOX LOCATION) AND POST APPROPRIATE WARNING SIGNS.

### SETTING THE STORED LIMIT SWITCH ADJUSTMENTS

- a) Remove the guard assembly (See "Figure 3: Remove/Replace the Guard Assembly" on page 5).
- b) Raise the restraint and place a 1/4" shim under the hooking arm (See "Figure 24: Adjusting the Stored Limit Switch" on page 26).
- c) Lower the restraint onto the 1/4" shim and block the restraint from rising off the shim.
- d) Loosen the set screw on the limit switch roller arm.
- e) Adjust the position of roller arm until the roller contacts the hook arm.

**NOTE:** To make vertical roller adjustment, loosen the screw and slide the roller arm up or down as required.

To make rotational adjustment of the roller arm, remove the screw and carefully pull off the roller arm and reattach the roller arm to switch head at the desired angle. Angular adjustment can only be made at 10 degree increments or multiples of 10 degrees.

- f) Tighten the screw of the roller arm.
- g) Raise the restraint; remove the 1/4" shim and any blocking device used to prevent the restraint from rising. Store the restraint with no shim and confirm the outside green light is illuminated.
- h) Unlatch the restraint and place 3/4" shim under the hook arm.
- i) Lower the restraint onto the 3/4" shim and block the restraint from rising off the shim and confirm that the outside red light is illuminated.

**NOTE:** When the restraint is in the stored position with **no shim** under the hooking arm, the **outside green light** should be illuminated.

When the restraint is in the lowered position with the 3/4" shim under the hook arm, the **outside red light** should be illuminated.

Repeat items b) to f) until this is accomplished.

- j) Remove all shims and blocking device
- k) Reinstall the guard assembly.

Generic manual for reference only. Contact Pentallift with product serial number to receive owners manual for your specific equipment.

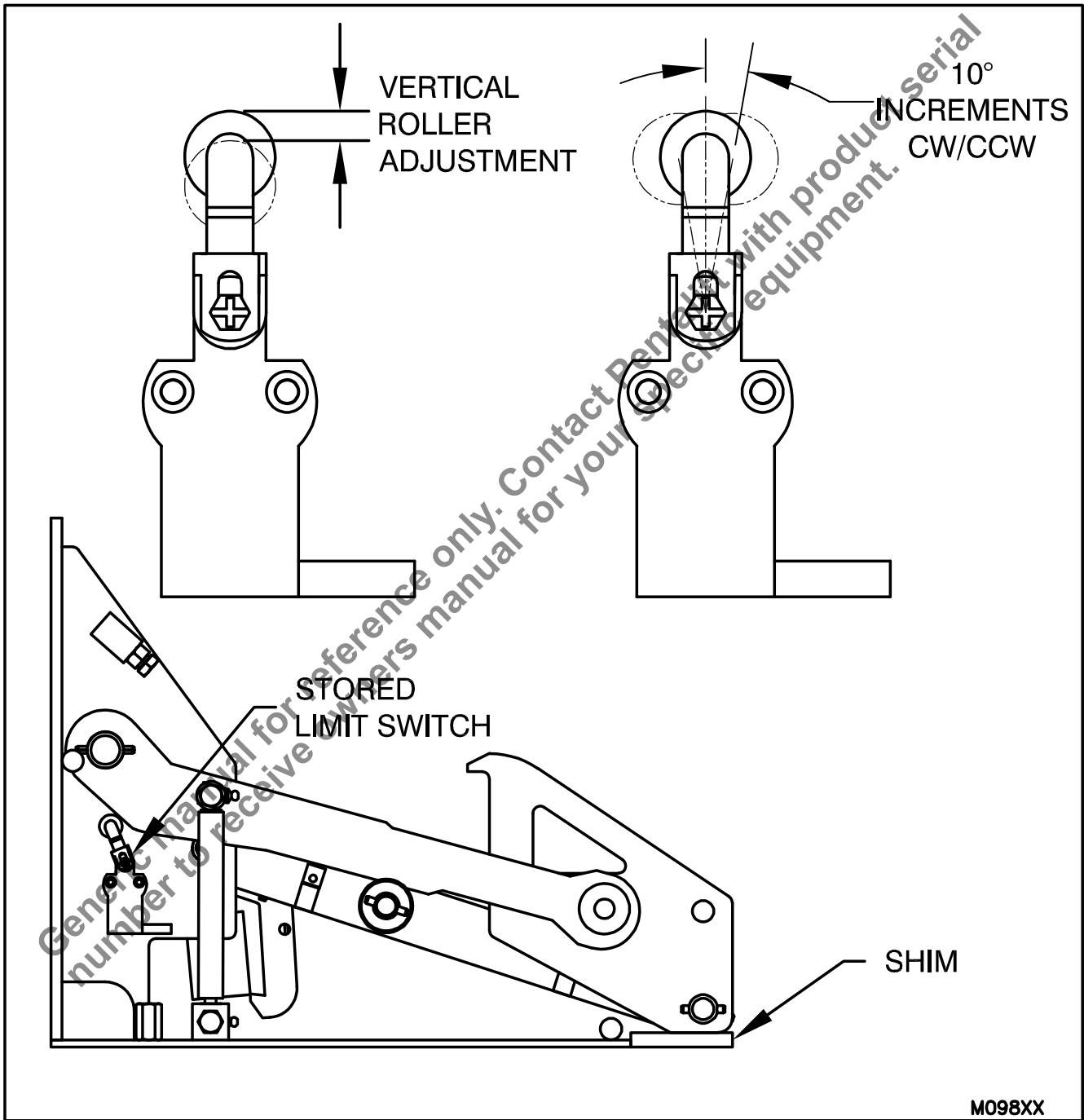

Figure 24: Adjusting the Stored Limit Switch

# REPLACEMENT PARTS

USE ONLY GENUINE PENTALIFT REPLACEMENT PARTS



To ensure proper functioning, durability and safety of the product, only genuine pentlift replacement parts must be used. Altering the product from its original manufactured configuration must not be done. Pentlift equipment Corporation disclaims all liability for failure to comply with this warning. Warranties are specifically disclaimed in the event the purchaser fails to comply with this warning.

To expedite order processing when ordering parts, provide the following information to your Pentlift representative:

1. Model and Serial Number of equipment.
2. Part Number, Description and Quantity.
3. Shipping Instructions.

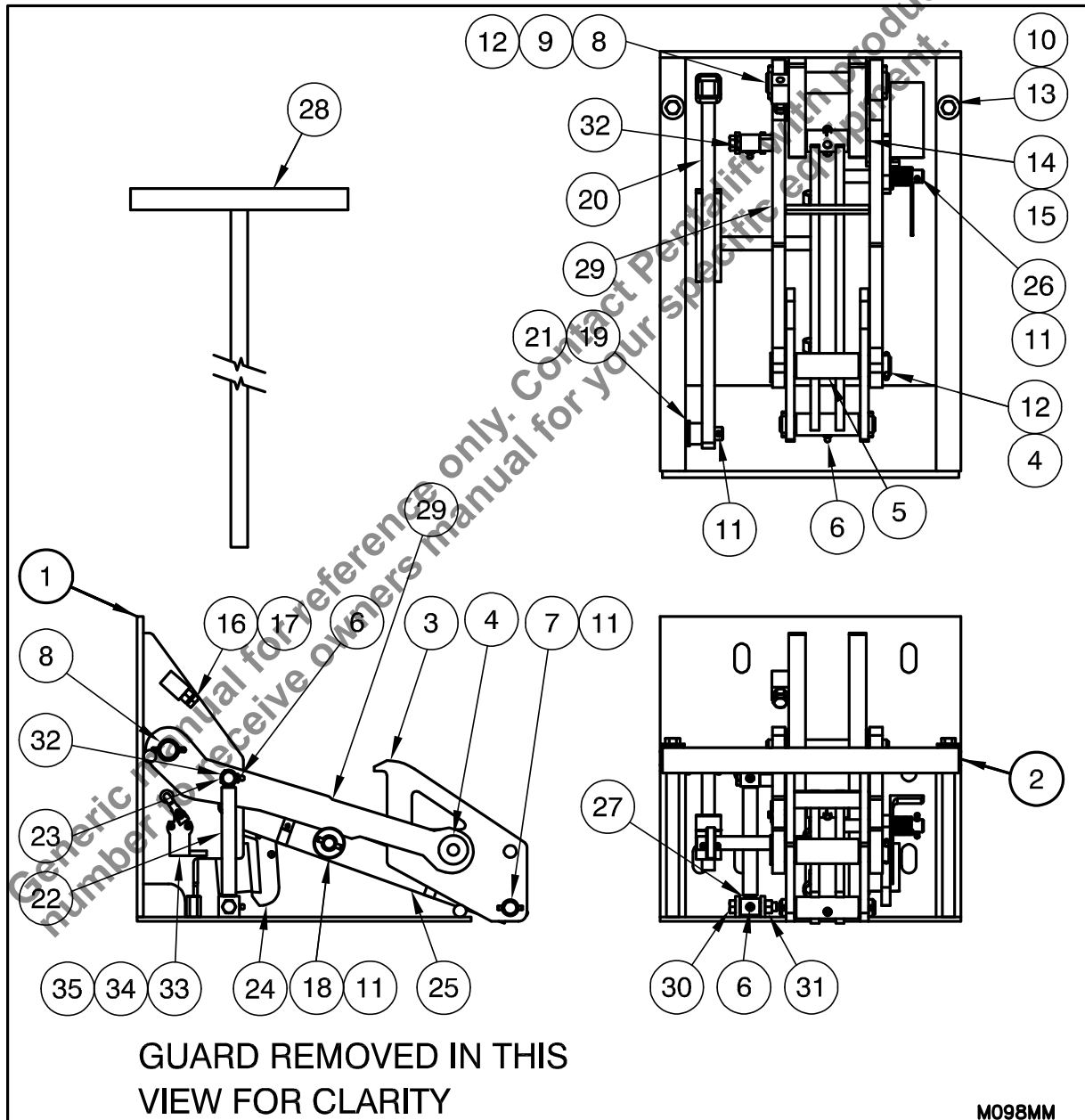

Figure 25: Restraint Replacement Parts

# RESTRAINT REPLACEMENT PARTS LIST

USE ONLY GENUINE PENTALIFT REPLACEMENT PARTS

| ITEM | PART NUMBER | DESCRIPTION                          |
|------|-------------|--------------------------------------|
| 1    | 812-0074    | Frame Weldment                       |
| 2    | 812-0003    | Guard Weldment                       |
| 3    | 312-0077    | Drilled Hook                         |
| 4    | 812-0055    | Upper Pin Weldment                   |
| 5    | 312-0017    | Hook Spacer                          |
| 6    | 052-0170    | Zerk Fitting                         |
| 7    | 312-0112    | Lower Arm Pin                        |
| 8    | 312-0113    | Upper Arm Pin                        |
| 9    | 074-0092    | 1" Flat Washer                       |
| 10   | 072-0275    | Hex Bolt 1/2-13 UNC x 10" LG.        |
| 11   | 080-0041    | Spring Pin 1/4" Dia. X 1 1/2" LG.    |
| 12   | 080-0042    | Spring Pin 1/4" Dia. X 2" LG.        |
| 13   | 074-0004    | 1/2" AA Flat Washer - Zinc           |
| 14   | 312-0156    | Lower Arm Flush Pin                  |
| 15   | 080-0021    | Spring Pin 1/4" Dia. X 1 1/4" LG.    |
| 16   | 070-0006    | Hex Nut 1/2-13 UNC Zinc              |
| 17   | 072-0001    | Hex Bolt 1/2-13 UNC 1 1/2" LG.       |
| 18   | 090-0006    | Roller Bearing                       |
| 19   | 074-0035    | 3/4" Flat Washer                     |
| 20   | 812-0063    | Push Down Arm Weldment               |
| 21   | 095-0050    | Push Down Arm Bushing                |
| 22   | 097-0040    | Gas Shock Spring                     |
| 23   | 300-8112    | Lower Gas Spring Pivot Tube          |
| 24   | 812-0064    | Latch Weldment                       |
| 25   | 812-0096    | Lower Arm Beam Assembly              |
| 26   | 300-8130    | Torsion Spring                       |
| 27   | 074-0011    | 5/16" Flat Washer                    |
| 28   | 800-8101    | Push Bar Assembly                    |
| 29   | 812-0076    | Upper Arm Weldment Assembly          |
| 30   | 072-0141    | Hex Bolt 1/2-13 UNC X 2 1/2" LG.     |
| 31   | 070-0017    | Hex Nylock Nut 1/2-13 UNC - Zinc     |
| 32   | 072-0242    | Shoulder Bolt 1/2" Dia. X 1 1/4" LG. |
| 33   | 0600962     | Limit Switch                         |
| 34   | 072-0118    | Machine Screw 10-32 x 3/4" LG.       |
| 35   | 074-0068    | Lock Washer #10                      |

**NOTE:** State Model # and Serial # when ordering replacement parts.

# CONTROL PANEL REPLACEMENT PARTS

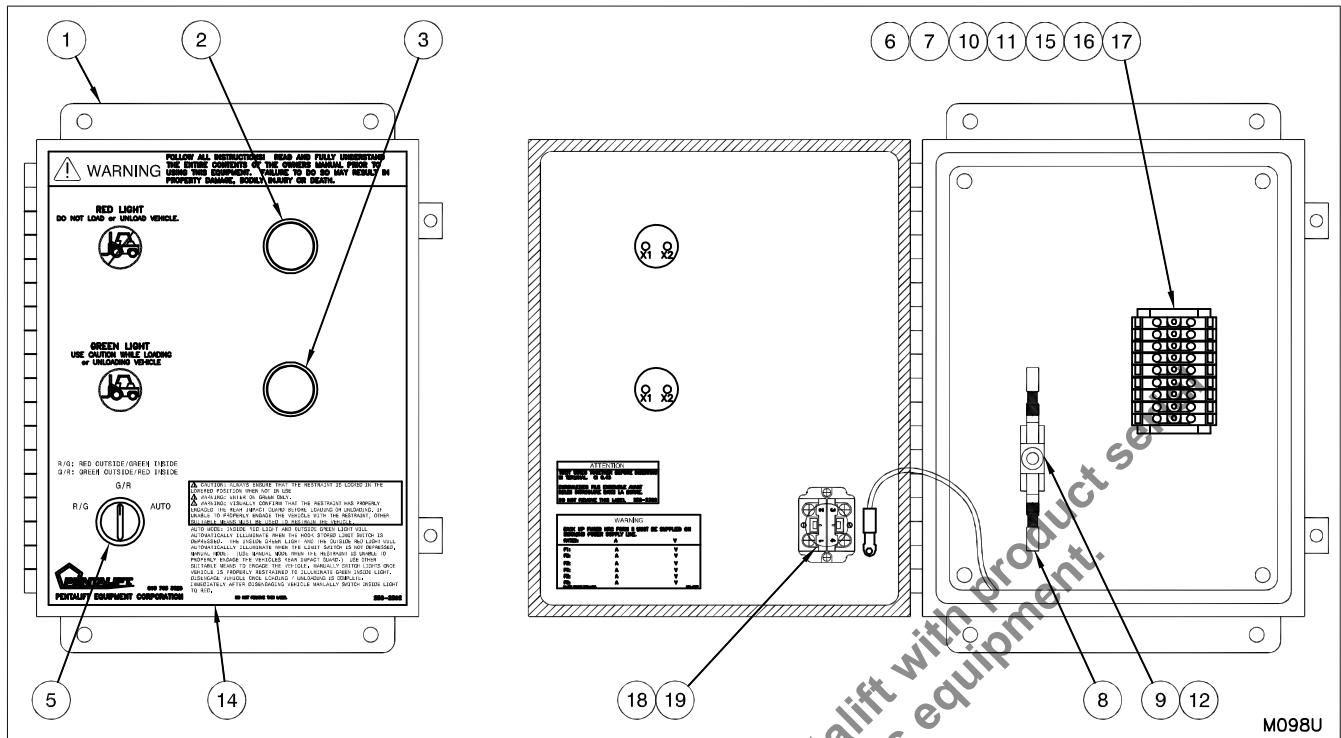

Figure 26: Control Panel Replacement Parts

| <u>Item</u> | <u>Part No.</u> | <u>Description</u>          |
|-------------|-----------------|-----------------------------|
| 1           | 060-0004        | Electrical Enclosure        |
| 2           | 060-1065        | Red Light                   |
| 3           | 060-1066        | Green Light                 |
| 4           |                 |                             |
| 5           | 161VRSW         | Switch Assembly             |
| 6           | 060-0568        | Jumper Bar                  |
| 7           | 060-0464        | Terminal Block End Stop     |
| 8           | 060-0203        | Crimp                       |
| 9           | 060-0380        | Fuse Holder                 |
| 10          | 060-0293        | Din Rail                    |
| 11          | 060-0463        | Terminal Block End Plate    |
| 12          | 060-0316        | Spiral Wound Glass Fuse     |
| 13          |                 |                             |
| 14          | 250-2592        | Instruction Label           |
| 15          | 060-0548        | Terminal (Beige)            |
| 16          | 060-1056        | Terminal Self Grounding     |
| 17          | 060-0466        | Terminal Markers            |
| 18          | 060-0717        | Push Button Mounting Collar |
| 19          | 060-0715        | Push Button Contact Block   |

**NOTE:** State Model # and Serial # when ordering replacement parts.

# DELUXE OUTSIDE LIGHT REPLACEMENT PARTS

USE ONLY GENUINE PENTALIFT REPLACEMENT PARTS

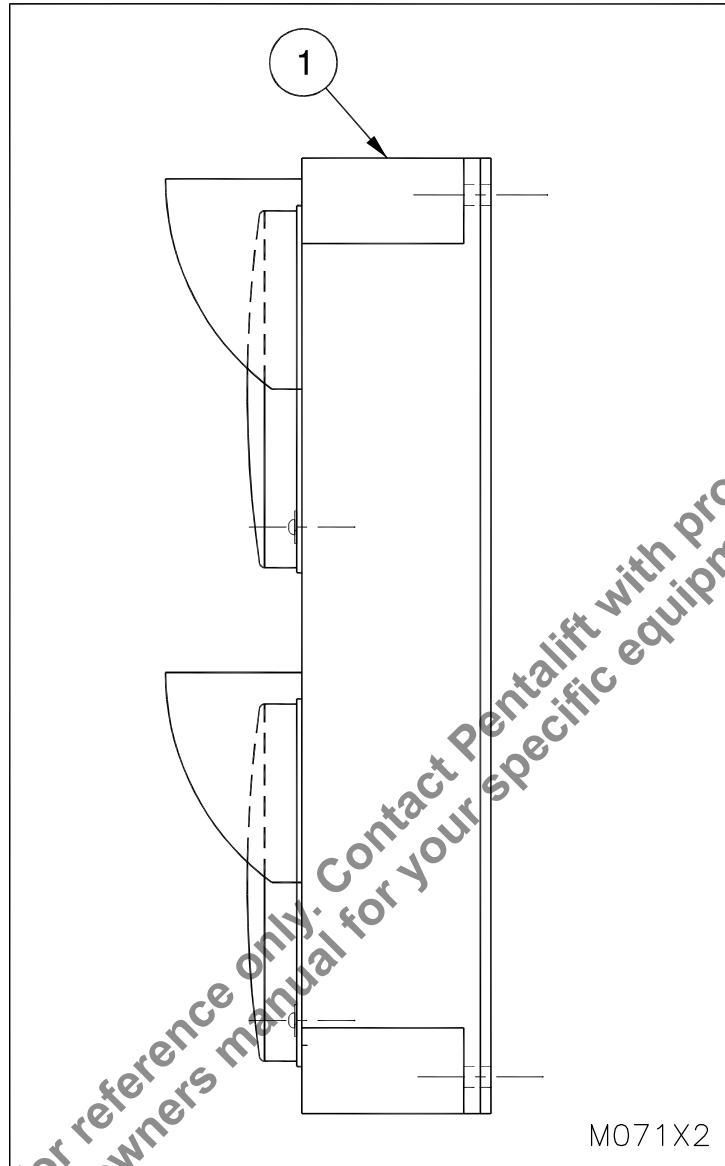
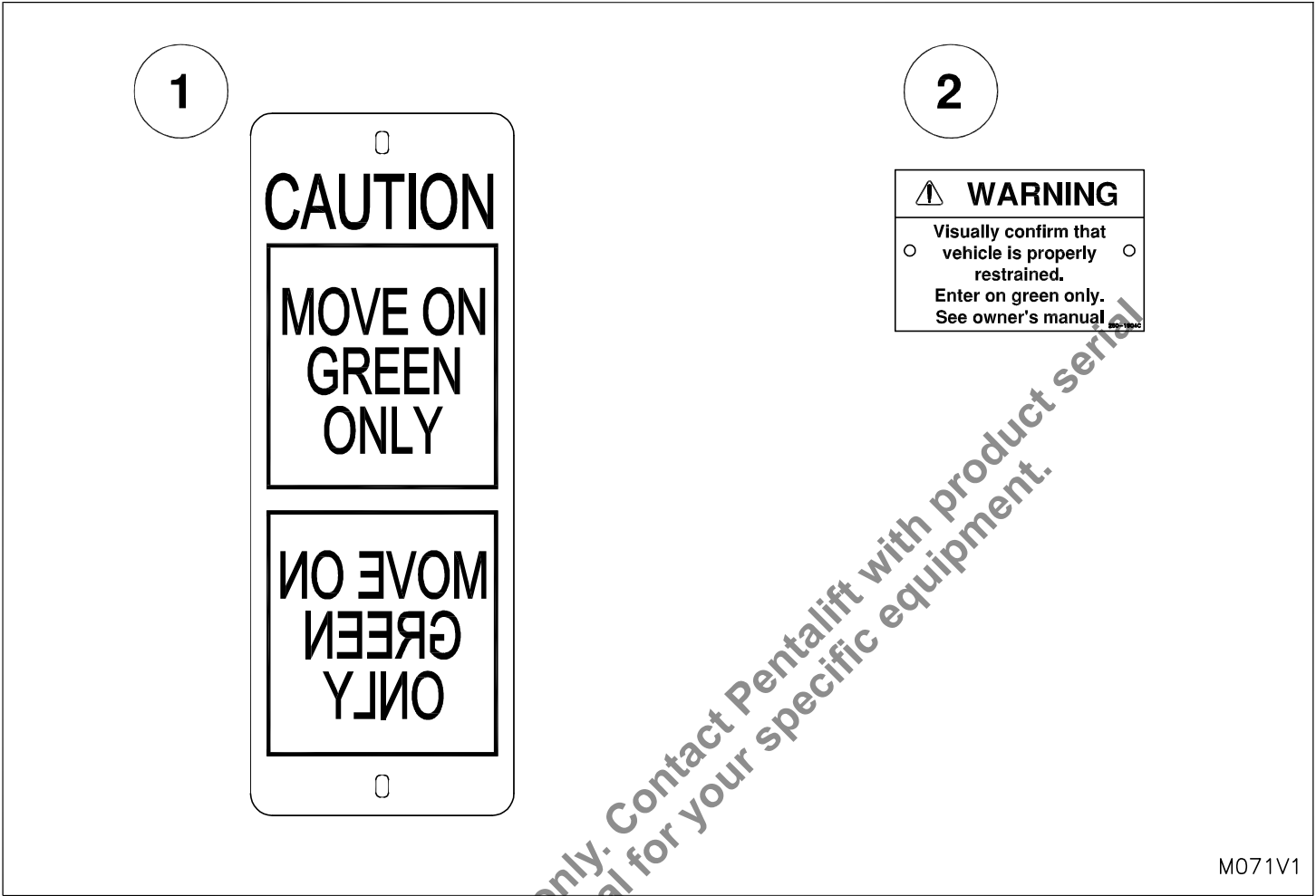

Figure 27: Traffic Light Replacement Parts

| <u>Item</u> | <u>Part No.</u> | <u>Description</u>        |
|-------------|-----------------|---------------------------|
| 1           | 060-1271        | 12V Traffic Light Fixture |

**NOTE:** State Model # and Serial # when ordering replacement parts.

# REPLACEMENT SIGNS



M071V1

Figure 28: Replacement Signs

Generic manual for reference only. Contact Pentalift with product serial number to receive owners manual for your specific equipment.

| <u>Item</u> | <u>Part No.</u> | <u>Description</u>               |
|-------------|-----------------|----------------------------------|
| 1           | 250-6991        | Caution Sign-Move on Green Only  |
| 2           | 250-1904        | Interior Shipper / Receiver Sign |

# LIST OF ILLUSTRATIONS

|   |    |
|---|----|
| Figure 1: Precautionary Labels .....  | 2  |
| Figure 2: Draw Pull Forces .....  | 4  |
| Figure 3: Remove/Replace the Guard Assembly.....  | 5  |
| Figure 4: Shim Locations .....  | 5  |
| Figure 5: Lag Locations.....  | 5  |
| Figure 6: Weld Locations.....   | 6  |
| Figure 7: Shim Locations for Optional Extension.....                                      | 7  |
| Figure 8: Optional Extension.....   | 8  |
| Figure 9: Horizontal Surface Mounting Installation .....                                  | 10 |
| Figure 10: Light, Sign and Conduit Locations.....   | 12 |
| Figure 12: Dock Ready to Receive Vehicle .....  | 16 |
| Figure 13: Restraint Stored - Push Latch to Release .....                                 | 16 |
| Figure 14: Set Selector Switch to “AUTO” When Ready to Receive a Vehicle.....             | 17 |
| Figure 15: Vertical Locking Arm Position .....  | 17 |
| Figure 16: Inside Light Green When Selector Switch Set to “AUTO”.....                     | 18 |
| Figure 17: Vehicle Secure .....   | 18 |
| Figure 18: Driver Signal.....   | 18 |
| Figure 19: R.I.G. Not Secure .....  | 19 |
| Figure 20: Secure Trailer by Other Means .....  | 19 |
| Figure 21: Restraint Raised-Push Arm to Release Vehicle / Return to Stored Position ..... | 19 |
| Figure 22: Lubrication Points .....   | 21 |
| Figure 23: Raised Height Adjustment.....  | 22 |
| Figure 24: Adjusting the Stored Limit Switch.....   | 26 |
| Figure 25: Restraint Replacement Parts.....   | 27 |
| Figure 26: Control Panel Replacement Parts.....   | 29 |
| Figure 27: Traffic Light Replacement Parts .....  | 30 |
| Figure 28: Replacement Signs .....  | 31 |

Generic manual for reference only. Contact Pentalift with product serial number to receive owners manual for your specific equipment.

# PENTALIFT EQUIPMENT CORPORATION WARRANTY

## WARRANTY

**Pentalift Equipment Corporation** expressly warrants that any product manufactured by **Pentalift Equipment Corporation** will be free from defects in material and workmanship under normal use for a period of one (1) year from the date of shipment of the equipment, provided the original purchaser maintains and operates the product in accordance with proper procedures. In the event the product proves defective in material or workmanship, **Pentalift Equipment Corporation** will at its option:

1. Replace the product or the defective portion thereof without change to the purchaser; or
2. Alter or repair the product; on site or elsewhere, as **Pentalift Equipment Corporation** may deem advisable, without charge to the purchaser.

The warranty stated in the previous paragraph is that expressed by **PENTALIFT EQUIPMENT CORPORATION** AND IS IN LIEU OF ALL GUARANTEES AND WARRANTIES, EXPRESSED OR IMPLIED BY ANYONE OTHER THAN **PENTALIFT EQUIPMENT CORPORATION**. This warranty does not cover any failure caused by improper installation, misapplication, overloading, abuse, negligence, or failure to lubricate and adjust or maintain the equipment properly and regularly. Parts requiring replacement due to damage resulting from abuse, improper operations, improper or insufficient lubrication, lack of proper protection or vehicle impact are not covered by this warranty. **Pentalift Equipment Corporation** assumes no responsibility or liability for:

1. Consequential damages of any kind which result from use or misuse of the equipment.
2. Damage or failure resulting from the use of unauthorized replacement parts.
3. Damage or failure resulting from modification of the equipment.
4. Damage resulting from the misuse of the equipment.

THERE ARE NO WARRANTIES, EXPRESSED OR IMPLIED, WHICH EXTEND BEYOND THE DESCRIPTION ON THE FACE HEREOF, AND THERE IS NO WARRANTY OF MERCHANTABILITY OR OF FITNESS FOR A PARTICULAR PURPOSE.

**Pentalift Equipment Corporation** warranties extend only to the original product itself. In no event shall **Pentalift Equipment Corporation** be responsible for or liable to anyone, including third parties, for special, indirect, collateral, punitive, incidental or consequential damages, even if **Pentalift Equipment Corporation** has been advised of the possibility of such damages. Such excluded damages include, but are not limited to, loss of good will, loss of profits, loss of use, interruption of business or other similar indirect financial loss.

**Pentalift Equipment Corporation** DISCLAIMS all liability arising out of the workmanship, methods and materials used by the installer.

**Pentalift Equipment Corporation** DISCLAIMS all liability for premature product wear, product failure, property damage or bodily injury arising from improper installation and application.

**Pentalift Equipment Corporation** will not accept any warranty for which the original purchaser does not notify **Pentalift Equipment Corporation's** Warranty Department of the defect within ninety (90) days after the product defect is discovered. A fully completed Product Registration Card is required prior to the review or processing of any warranty requests or claims.

WARRANTIES, whether expressed or implied, relating to workmanship and materials used in connection with the installation of **Pentalift Equipment Corporation** products are specifically DISCLAIMED.

WR001R02



P.O. Box 1510, Buffalo, NY, U.S.A. 14240-1510  
Phone: (519) 763-3625 □ FAX (519) 763-2894  
21 Nicholas Beaver Rd, Puslinch, Ontario, N0B 2J0 Canada  
Phone: (519) 763-3625 □ FAX (519) 763-2894

**NOTE:** All Pentalift Equipment Corporation products are subject to design improvement through modification without notice.