



PENTALIFT EQUIPMENT CORPORATION

AIR POWERED DOCK LEVELER OWNERS MANUAL

MODEL NUMBER : _____ SERIAL NUMBER : _____

CAPACITY : _____

Individual Model Number(s) and Serial Number(s) must be filled out by the user for future reference.

This manual is an important document.

It shall be kept with the machine or located where readily available to operators and maintenance personnel for reference purposes. Do not install, operate or service this product unless you have read and fully understand the entire contents of this manual. Failure to do so may result in property damage, bodily injury or death. Keep this manual in a safe place for future reference.

NOTE: A very high level of field issues with this type of equipment can be directly attributed to improper or incomplete installation. The installation instructions and information provided for this equipment is thorough. A step by step sequence for installation is provided. All steps must be followed and completed to provide a complete installation. Incomplete or improper installations can lead to equipment malfunction and / or damage, create safety issues and void warranties. Please follow all installation and set ups steps as indicated in the installation instructions and owner's manual. If you are unclear or uncertain regarding any of the steps contact your Pentalift representative for clarification. A copy of the completed steps listing with the sign off and photos of the installation as indicated at the conclusion of the installation instructions will be required prior to any Pentalift factory trouble shooting assistance.

**Pentalift Equipment Corporation
21 Nicholas Beaver Rd
Puslinch, ON N0B 2J0
Phone: 519-763-3625
Fax: 519-763-2894
Parts Phone: 519-763-3625 Extension 625
Ask for Parts Department**

Pentalift Equipment Corporation provides an owners manual when equipment is shipped. Additional manuals are available at \$25.00 each.

IMPORTANT: The owners manuals that are provided on Pentalift Equipment Corporations website are generic in nature. They are provided for general information only. For all purposes, only the owners manual that is specific to the equipment should be referenced and relied on. In order to receive the specific owners manual for specific Pentalift equipment, please contact your Pentalift representative and supply the specific serial number(s) for the equipment the manual is required for. Do not rely on the information in the generic owners manuals provided through the website as it may not be appropriate for your specific Pentalift equipment.

PRODUCT REGISTRATION

PRODUCT REGISTRATION



PRODUCT REGISTRATION CARD

To validate warranty and to advise of product updates please complete the following information and return to

Pentalift Equipment Corporation

To validate warranty on-line go to: www.pentalift.com

End User Information

*Company Name:		
Contact *First Name:	*Last Name:	Title:
*Mailing Address:		
*City:	*State/Prov.	*Zip/Postal Code:
*Phone: () -	Fax: () -	Email:
Check Products Purchased: <input type="checkbox"/> Levelers, <input type="checkbox"/> Vehicle Restraints, <input type="checkbox"/> Seals/Shelters, <input type="checkbox"/> Elevating Docks, <input type="checkbox"/> Lift Tables		
*Serial Number(s):	Invoice # (if available):	
Dealer Name:	Sales Rep.:	
Manual Verification *Manual Number:		

*Indicates information that must be provided.

Please return to:

Pentalift Equipment Corporation
P.O. Box 1510,
Buffalo, NY 14240-1510

or

Pentalift Equipment Corporation
21 Nicholas Beaver Rd
Puslinch, Ontario N0B 2J0

Attention: Service Department

Or Fax to (519) 763-2894

SAFETY INFORMATION AND WARNINGS



READ THESE SAFETY PRACTICES BEFORE INSTALLING, OPERATING OR SERVICING THE DOCK LEVELER. FAILURE TO FOLLOW THESE SAFETY PRACTICES MAY RESULT IN PROPERTY DAMAGE, BODILY INJURY OR DEATH.

THE OPERATION OF THIS EQUIPMENT IS SUBJECT TO CERTAIN HAZARDS THAT CAN BE PROTECTED AGAINST ONLY BY THE EXERCISE OF CARE AND COMMON SENSE AND NOT BY MECHANICAL MEANS. IT IS, THEREFORE, ESSENTIAL TO HAVE COMPETENT, QUALIFIED OPERATORS TRAINED IN THE SAFE OPERATION AND CARE OF THIS TYPE OF EQUIPMENT. ALL PERSONNEL MUST COMPLETELY UNDERSTAND THIS SAFETY INFORMATION BEFORE WORKING ON OR NEAR THIS EQUIPMENT.



DANGER indicates an imminently hazardous situation which, if not avoided, will result in death or serious injury.



WARNING indicates a potentially hazardous situation which, if not avoided, could result in death or serious injury.



CAUTION, used with the safety alert symbol, indicates a potentially hazardous situation which, if not avoided, could result in minor or moderate injury.

NOTICE

NOTICE is used to address practices not related to personal injury.



Before doing any installation, maintenance, inspection or trouble shooting, barricade all areas from traffic around the work area inside (and outside if applicable) for safety and post appropriate warning signs.



Arc flash and shock hazard PPE (personal protection equipment) required. De-energize equipment before working on or inside. Do not open cover without appropriate PPE. Refer to NFPA 70E for PPE requirements. This panel may contain more than one power source. Hazardous voltage will cause severe injury or death.



Before doing any electrical work, be certain that the power is disconnected with a fused disconnect, properly tagged and locked out. Fused disconnect and lockout device (supplied and installed by others) must meet with all applicable codes and regulation. All electrical work must be performed by a qualified electrician in accordance with all applicable codes and regulations.



NEVER GO BENEATH THE DOCK LEVELER FOR ANY REASON UNLESS THE DECK AND LIP ARE PROPERLY SUPPORTED (SEE "SUPPORTING THE LEVELER FOR MAINTENANCE" on page 49) AND THE POWER IS DISCONNECTED WITH A FUSED DISCONNECT, PROPERLY TAGGED AND LOCKED OUT. IT IS THE RESPONSIBILITY OF THE OWNER TO ENSURE THAT NO LOAD OR TRAFFIC IS PLACED ON THE DECK WHILE THE MAINTENANCE STAND IS ENGAGED. THE MAINTENANCE STAND IS ONLY INTENDED TO SUPPORT THE WEIGHT OF THE UNLOADED DOCK LEVELER.



NEVER USE THE "DECK STOP" BUTTON (if equipped) AS A MEANS OF HOLDING THE DECK UP WHILE PERFORMING MAINTENANCE OR INSPECTION.



TO AVOID POSSIBLE PERSONNEL INJURY AS WELL AS, TO AVOID DAMAGE TO THE DOCK LEVELER AND/OR THE PRODUCT, DO NOT DRAG OR SLIDE ANYTHING ACROSS THE SURFACE OF THE DOCK LEVELER. ALWAYS ENSURE THE FORKLIFT FORKS ARE RAISED TO CLEAR THE DOCK LEVELER SURFACE AND THE DOCK LEVELER COMPONENTS.



NEVER WALK ON THE DOCK LEVELER LIP UNLESS IT IS FULLY EXTENDED AND SUPPORTED BY THE TRUCK BED.

⚠ DANGER

DOCK LEVELER CAPACITY: THE RATED CAPACITY OF THE DOCK LEVELER AS STATED ON THE SERIAL NUMBER PLATE IS A STATIC RATING. NUMEROUS DYNAMIC LOADING FACTORS RESULT IN THE GROSS LOAD CAPACITY (ROLLOVER CAPACITY) BEING SIGNIFICANTLY LESS THAN THE RATED STATIC CAPACITY OF THE DOCK LEVELER. FACTORS WHICH AFFECT THE ROLL OVER CAPACITY ARE: WEIGHT OF THE LOAD; WEIGHT OF THE FORK TRUCK; SPEED OF THE FORK TRUCK AS IT ROLLS OVER THE DOCK LEVELER; INCLINE OR DECLINE SLOPE OF THE DOCK LEVELER DECK AND LIP WHEN IN USE; FREQUENCY OF USE AND DESIRED LIFE OF THE DOCK LEVELER. PRIOR TO USING THE DOCK LEVELER, OR IF THE APPLICATION CONDITIONS FOR THE DOCK LEVELER CHANGE IN ANY RESPECT, CONTACT YOUR AUTHORIZED PENTALIFT REPRESENTATIVE TO CONFIRM THE SPECIFIC DOCK LEVELER'S SUITABILITY FOR THE APPLICATION.

Note On Capacity: The dock leveler capacity indicated on the serial plate must be divided with a factor to accommodate dynamic loading factors. For more information see Pentalift document - Dock Leveler Capacity – Understanding Loading Dock Capacity at <http://www.pentalift.com/dock-leveler-capacity.php>

⚠ DANGER

ALWAYS ASSURE NO ONE IS WITHIN 6 FEET OF THE FRONT (LIP END) OF THE DOCK LEVELER PRIOR TO ACTIVATION. STAY CLEAR OF DOCK LEVELER WHEN IT IS MOVING.

⚠ WARNING

It is the responsibility of others to ensure the proper mounting of any wall mounted equipment such as remote power units, control panels and light packages and to ensure that the mounting surface is capable of fully supporting the loads generated by the equipment.

NOTICE

OVERHEAD DOOR INTERLOCKS ARE FOR PROCEDURAL REASONS AND DO NOT PROVIDE ANY ADDITIONAL SAFETY FEATURES BEYOND THOSE THAT ARE STANDARD FOR THIS EQUIPMENT.

1. When not in use, the deck must be in the stored (cross traffic) position, with the lip inside the front angle. (See "Figure 54: Deck in (Cross Traffic) Stored Position" on page 47)
2. Before loading/unloading the truck, assure the trailer is in position firmly against both of the dock bumpers and **ENGAGE A VEHICLE RESTRAINT or CHOCK THE TRUCK WHEELS** to eliminate the possibility of the truck rolling or inching forward.
3. Return the dock leveler to the stored position before allowing the truck to depart.
4. Be certain no equipment, material or personnel are on the dock leveler before allowing truck to depart.
5. Regular inspection and maintenance must be performed to keep the equipment in proper operating condition in accordance with the detailed instructions in this manual.
6. Anyone using or in the vicinity of this equipment must wear protective footwear with steel toes.
7. The deck surface must be kept clean and free from oil, debris, etc. Keep debris, etc. from underneath the unit.
8. Never use a fork truck or any other weight to lower the deck from its raised position.
9. Do not operate, use, maintain or install this equipment if you are impaired in any manner.
10. Never stand between the dock and a truck.
11. Stay clear of operating path at all times.
12. Ensure that the equipment is not used by anyone if you believe that any part of it might be in disrepair (e.g. loose wires, leaking hoses, bent structural members, broken welds, etc.). See "INSTALLATION, INSPECTION, MAINTENANCE AND LUBRICATION" on page 57.
13. If you have any questions contact your immediate supervisor or your authorized Pentalift representative for assistance.
14. Do not continue to push and hold the raise button after the leveler has fully raised and the lip has extended, doing so can result in damage to the air bag and or to the dock leveler.
15. Take care to not damage/dislodge the air bag/tray assembly or other components under the dock leveler.
16. Review the dock leveler using a flashlight if required prior to activation to confirm the location of air bag assembly

OWNER RESPONSIBILITY

The Owner's Responsibilities include the following:

1. The owner shall recognize the inherent danger of the interface between dock and transport vehicle. The Owner shall, therefore, train and instruct operators in the safe use of dock leveling devices.
2. When a transport vehicle is positioned as closely as practicable to a dock leveling device, there shall be at least 4" (100 mm) of overlap between the front edge of the lip and the edge of the floor or sill of the transport vehicle.
3. Nameplates, cautions, instructions and posted warnings shall not be obscured from the view of operating or maintenance personnel for whom such warnings are intended.
4. Manufacturer's recommended periodic maintenance and inspection procedures in effect at date of shipment shall be followed, and written records of performance of these procedures shall be kept.
5. Dock leveling devices that are structurally damaged or have experienced a sudden loss of support while under load, such as might occur when a transport vehicle is pulled out from under the dock leveling device, shall be removed from service, inspected by **Pentalift Equipment Corporation's** authorized representative and repaired as needed before being placed back in service. The owner shall receive written authorization from **Pentalift Equipment Corporation** through the authorized Pentalift representative that they can continue to use the dock leveler.
6. **Pentalift Equipment Corporation** shall supply replacement nameplates, caution or instruction labels and operating and maintenance manuals upon request of the owner. The owner shall see that all nameplates and caution and instruction markings or labels are in place and legible and that the appropriate operating and maintenance manuals are provided to users.
7. Modifications or alterations of dock leveling devices shall be made only with written permission of **Pentalift Equipment Corporation**. Alteration permission must be signed by both the Pentalift Post Sale Customer Service Manager and the President to be valid.
8. When industrial trucks are driven on and off transport vehicles during the loading and unloading operation, the brakes on the transport vehicle shall be applied and wheel chocks or positive restraints that provide the equivalent protection of wheel chocks engaged.
NOTE: It is recognized that these devices are intended to secure a transport vehicle to a loading dock by mechanical means. However, no standards currently exist for the strength, construction or attachment of the underride guard on a transport vehicle. It is therefore recommended that users of such positive restraint devices review:
 - The means of attachment to the transport vehicle
 - The strength of the overall connection
 - The proper coordination of the actuation of devices with any signalling system used
 - The need to use wheel chocks
9. In selecting dock leveling devices, it is important to consider not only present requirements, but also future plans or adverse environments.



Unless specifically agreed to in writing by Pentalift Equipment Corporation at the time the equipment is ordered and prior to the equipment's manufacture, this equipment is sold as a complete package. It is not to be altered, changed or added to in any way or form, in its configuration and function, without the written permission of Pentalift Equipment Corporation.

If requested by a customer, Pentalift Equipment Corporation is not supplying all or some of the motor and / or control components for the equipment's application. The motor unit and controls constitute important safety and functional aspects of the equipment. It is the customer's responsibility to address the operational and safety issues associated with providing the required controls and power units to satisfy the operational and safety requirements of the equipment.

The customer's decision to supply all or some of these components indicates that the customer is taking full responsibility for any and all possible operational, safety and liability issues associated to the product and its configuration. The customer also agrees to absolve Pentalift Equipment Corporation from any and all possible operation, safety and liability issues.

TABLE OF CONTENTS

PRODUCT REGISTRATION	I
SAFETY INFORMATION AND WARNINGS.....	II
OWNER RESPONSIBILITY	IV
TABLE OF CONTENTS	1
PRECAUTIONARY LABELING	2
PREPARATION PRIOR TO INSTALLATION	8
INSTALLATION INSTRUCTIONS	8
INSTALLING LEVELER INTO PIT	10
LEVELING INSTRUCTIONS	15
INSTALLATION USING SHIM KIT	18
SELF CONTAINED POWER UNIT	18
INSTALLATION USING FILLER PLATE	24
INSTALLATION INSTRUCTIONS FOR 3-INCH FILLER PLATE	24
INSTALLATION INSTRUCTIONS FOR 4-INCH FILLER PLATE	25
FILLER PLATE INSTALLATION INSTRUCTIONS (WITH TWO TUBES & TWO SUPPORT BARS).....	26
FILLER PLATE INSTALLATION INSTRUCTIONS (WITH TWO TUBES & FOUR SUPPORT BARS).....	27
WELDING REFERENCE INFORMATION	28
INSTALLATION PICTURES (PIT INSTALLATION).....	29
ELECTRICAL REFERENCE CHART	29
INSTALLATION INSTRUCTIONS	32
POUR-IN DOCK LEVELERS	32
PREPARATION PRIOR TO INSTALLATION	32
air powered dock leveler:	37
INSTALLATION PICTURES (POUR-IN PAN).....	40
ELECTRICAL REFERENCE CHART	41
Bumper Installation Guide lines	42
Locating Dock Bumpers during installation.....	42
Installation methods I.E. Lagging and or welding:	42
BREAK-IN AND PERFORMANCE CHECK	45
OPERATING INSTRUCTIONS	46
END LOADING BELOW LEVEL CONTROL OPERATION.....	48
END LOADING / UNLOADING	48
SUPPORTING THE LEVELER FOR MAINTENANCE.....	49
TROUBLE SHOOTING GUIDE	52
INSTALLATION, INSPECTION, MAINTENANCE AND LUBRICATION.....	54
NORMAL SEQUENCES OF STEPS TO ADJUST MECHANICAL DOCK LEVELER THAT IS NOT PROPERLY FUNCTIONING.....	56
ADJUSTMENTS	56
LIP ASSIST SPRING ADJUSTMENT	57
LIP YIELD MECHANISM.....	58
REPLACEMENT PARTS	61
BLOWER ASSEMBLY REPLACEMENT PARTS	61
LIST OF ILLUSTRATIONS	66
PENTALIFT EQUIPMENT CORPORATION WARRANTY.....	68

PRECAUTIONARY LABELING

1 **LIFT 1 DOCK ONLY (WITH NO LOAD ON IT)**
FORKS HERE

DO NOT REMOVE THIS LABEL. 250-1127

250-1127
QTY. - 2 PER UNIT

2 **CAUTION**

THIS EQUIPMENT HAS BEEN BOLTED CLOSED FOR SHIPPING. REMOVE ALL SHIPPING BOLTS BEFORE OPERATING.

250-1141
QTY. - 1 PER UNIT

3 **INSPECTION**

DATE _____ INSPECTED BY _____

250-1148
QTY. - 1 PER UNIT

4 **IMPORTANT**

READ THE INSTALLATION INSTRUCTIONS AND OWNERS MANUAL IN THEIR ENTIRETY BEFORE INSTALLING AND/OR USING THIS EQUIPMENT.

250-2058
QTY. - 1 PER UNIT

5 **PENTALIFT**

250-1143
QTY. - 1 PER UNIT

6 **WARNING**

READ AND UNDERSTAND THE ENTIRE OWNERS MANUAL PRIOR TO INSTALLING, OPERATING, SERVICING OR MODIFYING THIS EQUIPMENT.

DO NOT REMOVE THIS LABEL.

MODEL: _____
SERIAL NO.: _____ CAPACITY: _____

NOTE: THE PLATED DOCK LEVELER CAPACITIES, AS INDICATED ON THE SERIAL NUMBER PLATE ARE SUBJECT TO DYNAMIC CAPACITY FACTOR. REFER TO THE PENTALIFT DOCUMENT "UNDERSTANDING LOADING DOCK CAPACITY". THIS DOCUMENT IS AVAILABLE FROM YOUR PENTALIFT REPRESENTATIVE OR AT WWW.PENTALIFT.COM/DOCK-LEVELER-CAPACITY. CONTACT YOUR PENTALIFT REPRESENTATIVE WITH ANY QUESTIONS OR CLARIFICATIONS RELATED TO THE PLATED CAPACITY AND THE DYNAMIC CAPACITY FACTOR THAT APPLIES FOR A SPECIFIC APPLICATION.

MADE IN CANADA 1-(819)-763-3625 WWW.PENTALIFT.COM 250-1817

250-1817
QTY. - 1 PER UNIT

8 **WARNING**

TO AVOID PERSONAL INJURY READ OWNERS MANUAL BEFORE OPERATING

DANGER UP TO 1200 LB DOWN TO 1200 LB
PENTALIFT
STAND CLEAR

DANGER UP TO 1200 LB DOWN TO 1200 LB
WARNING

TO AVOID PERSONAL INJURY READ OWNERS MANUAL BEFORE OPERATING

250-2000
QTY. 1 PER UNIT

9 **DANGER**

Unupported dock leveler ramps can lower unexpectedly.

Before allowing vehicle to leave the dock, always:

- * Ensure that no equipment, material or people are on the dock leveler.
- * Return the dock leveler to its stored position at dock level.

Failure to follow posted instructions will result in death or serious injury.

DO NOT REMOVE THIS LABEL.

SAFETY INFORMATION

OPERATION

- Read and follow all instructions and warnings in the owner's manual.
- Use of dock leveler restricted to properly trained operators.
- Always check trailer wheels and engage trailer restraint before operating dock leveler or beginning to load or unload.
- Never use hands or equipment to move ramp or lip.
- Before actuating dock leveler:
 - Ensure trailer is locked in against bumpers.
 - Remove any and loads if required.
 - Check trailer alignment to avoid lip interference. If lip does not lower to trailer bed, reposition vehicle.
- Ensure truck bed supports extended lip or leveler frame supports the ramp before driving on ramp.

MAINTENANCE/SERVICE

- Read and follow all instructions, warnings, and maintenance schedules in the owner's manual.
- Maintenance/Service of dock leveler restricted to properly trained personnel.
- Place barriers on driveway and dock floor to show service work is being performed.
- DO NOT ENTER PIT unless dock leveler is securely supported by maintenance stand.
- If electrically powered, turn off and use OSHA lockout/tagout procedures.

7. Stay clear of hinges and front end sides of moving dock leveler.

8. Never use damaged or malfunctioning dock leveler. Report problems immediately to supervisor.

Call 519-763-3625 for replacement placards, warning labels, or owner's manual. 250-2320

250-1882
QTY. 2 PER UNIT

250-2320
QTY. 2 PER UNIT

M092D2-1A

Figure 1: Precautionary Labels

⚠ DANGER

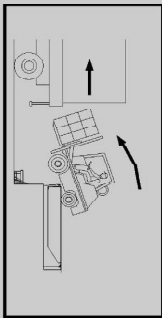

- Read and follow all instructions, warnings and maintenance schedules in the owner's manual and on placards.
- Restrict use or service of dock leveler to properly trained personnel.
- Always chock trailer wheels or engage trailer restraint and set parking brakes and dump air before operating dock leveler or beginning to load/unload.

- Before activating dock leveler, ensure lip avoids contact with trailer sides and cargo. If lip does not lower to trailer bed, reposition trailer.
- Ensure that the truck bed sufficiently supports the extended lip or the leveler frame properly supports the deck before driving on deck.
- Stay clear of hinges and front and sides of moving dock leveler.
- Never use hands or equipment to move the deck or lip.
- Never use damaged or malfunctioning dock leveler. Report problems immediately to supervisor.
- Always store dock leveler and remove people, material, and equipment from deck before vehicle leaves the dock.
- **DO NOT ENTER PIT** unless dock leveler is securely supported by maintenance stand. (Refer to owner's manual)
- Disconnect power and properly tag or lock out dock leveler before entering the dock leveler pit or doing any repair or inspection under the dock leveler.
- Barricade all areas from traffic around the work area inside (and outside if applicable) for safety and post appropriate warning signs.

DANGER! Failure to follow these instructions could result in death or serious injury.

OPERATING INSTRUCTIONS

FOR AIR POWERED DOCK LEVELER WITH BUTTON CONTROL

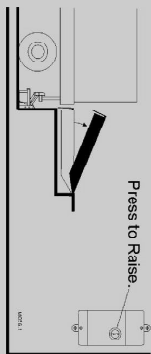

- Normal operation*
- 1) With trailer in position **press the raise button** on the control panel to raise the dock leveler.
Warning: Be sure that no person is standing on the deck, lip or near the sides or front of the dock leveler prior to cycling the equipment

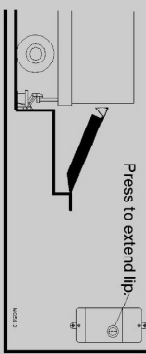

- 2) Continue to press the button. The lip will automatically extend as the dock leveler deck is fully raised.
Warning: DO NOT continue to push and hold the raise button after the leveler has fully raised and lip has extended, doing so can result in damage to the Air Bag and/or to the dock leveler.

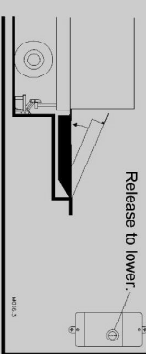

- 3) When dock leveler deck is fully raised and the lip is fully extended release the button. The leveler will float down to the truck bed. If necessary, release the optional fall safe legs to allow the dock leveler to float below level. Commence loading/unloading. *Note:* Restore the leveler to the dock level storage position for end loading. (See owner's manual for more details)
Warning: Never drive onto the dock leveler unless it is supported by the truck bed or by the below level stops. Damage to the air bag could result.
Warning: DO NOT continue to push and hold the raise button after the leveler has fully raised and lip has extended, doing so can result in damage to the Air Bag and/or to the dock leveler.

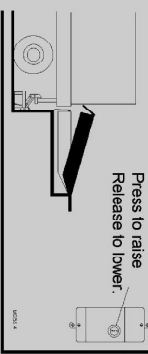

- Storing leveler after loading/unloading complete*
- 1) To return the leveler to stored position, **press the button**. As the leveler raises the lip will retract. When the lip is fully retracted and above the lip keepers, **release the button**. The leveler will float down to the stored position. Confirm lip is properly positioned behind lip keepers. (See owner's manual for more details)

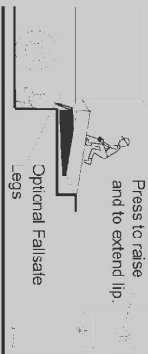

- Below dock end loading (if equipped)*
- 2) **Press the button** until leveler is fully raised and the lip just starts to extend. Release the button and walk onto the dock leveler to pull the below level release ring (located at the front of the dock leveler) before the dock leveler reaches the bottom stops. The lip will extend to clear the lip keepers as the dock leveler lowers to the below level stops. (See owner's manual for more details)



Telephone: (519) 763-3625
 Fax: (519) 763-2894
 Call number above for additional safety labels, or manuals, or with questions regarding proper use, maintenance, and repair of dock leveler.

250-6996A

Figure 2A: Operation Placard

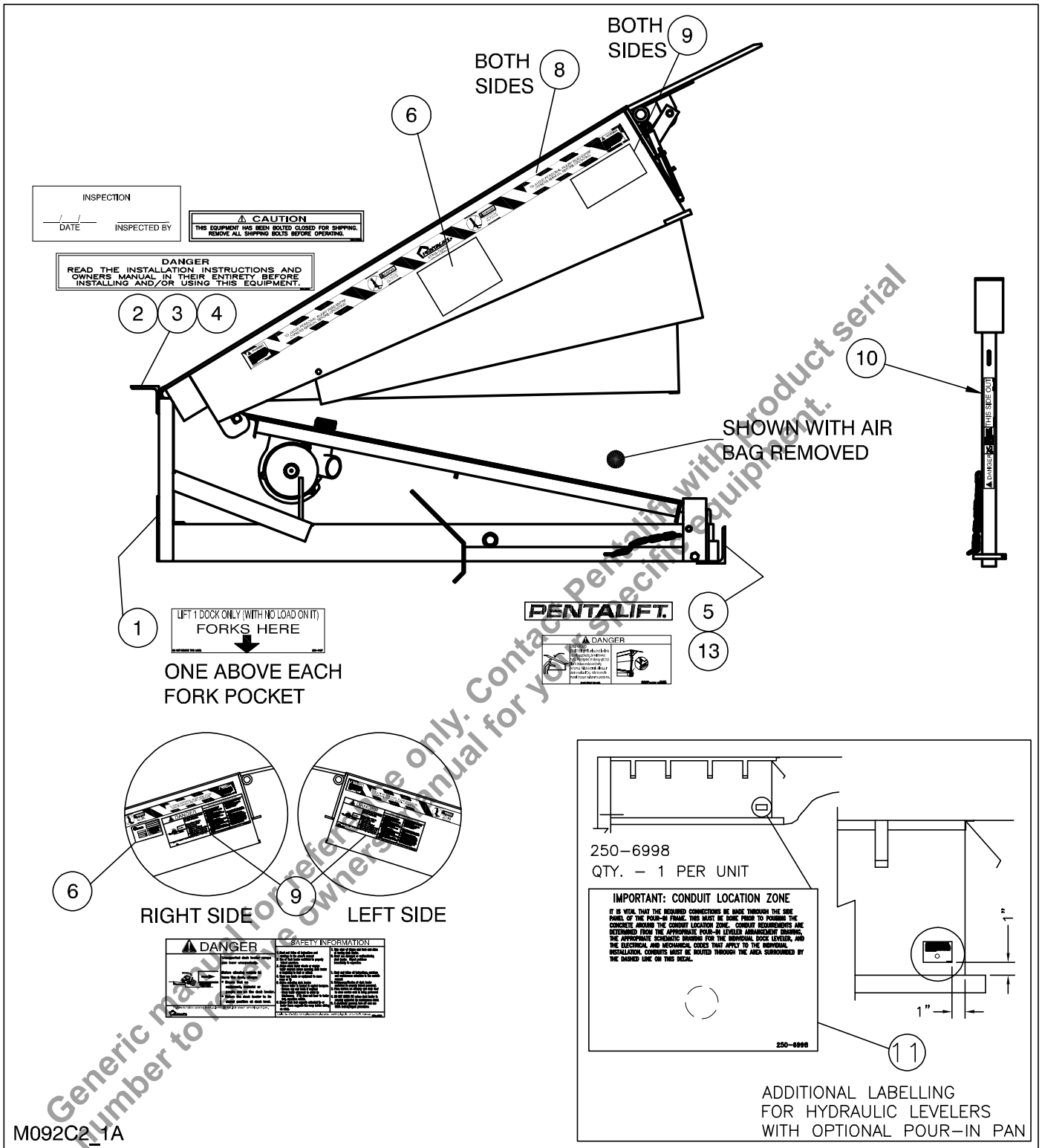

Figure 3: Precautionary Label Location

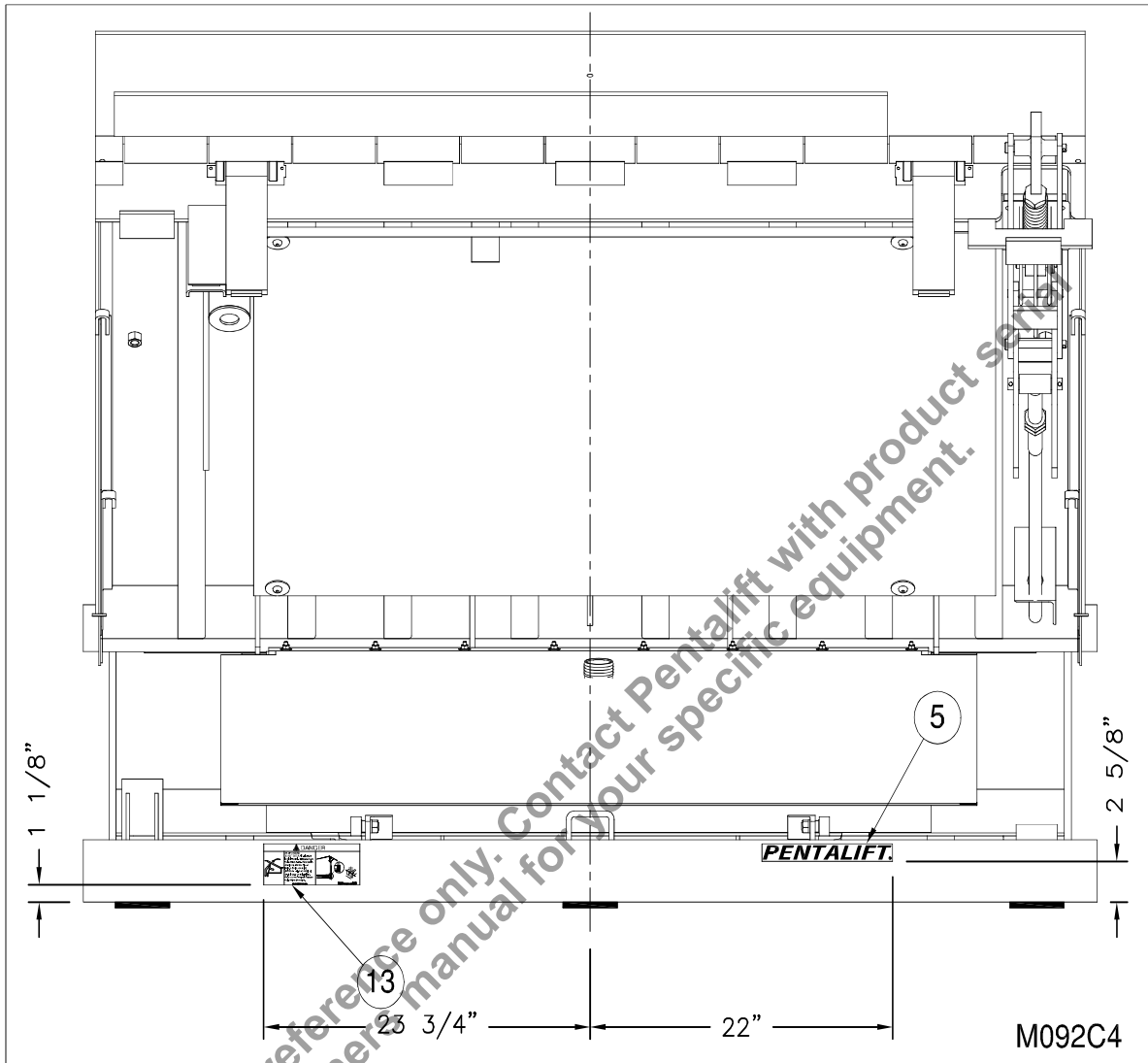

Figure 3a: Precautionary Label Location - Front Angle

(Shown with Air Bag removed for clarity)

Be sure that all labeling is in place and intact when the unit is received. If any of the precautionary labels are missing or illegible, contact your Pentalift representative for immediate replacement.

NOTE: In some instances, product configuration and / or product options may dictate that the product labels will not be placed as indicated on the drawing (“Figure 3: Precautionary Label Location” on page 5). Different label locations will be selected at the factory, when required, to avoid an impaired view of the labels. Note the label locations as supplied on the product, when it is received to accommodate future label replacement requirements.

NOTE: It is the owner’s responsibility to assure that all precautionary labeling remains legible and in its original position throughout the life of the product. It is also the owner’s responsibility to assure that all labels are and will continue to be readily visible to the operators and people working with and around the equipment. If the visibility of any label is compromised for any reason then; either 1) Rectify the situation to allow the label to be readily visible 2) Order replacement label(s) from Pentalift for installation in a location that does facilitate complete visibility. If any of the precautionary labels are missing or illegible, contact your Pentalift representative for immediate replacement. Inspection shall be done during regular maintenance and lubrication (MAINTENANCE AND LUBRICATION on page 57).

To re-order precautionary labels, use the following part numbers:

ITEM NO.	PART NO.	QTY/UNIT	DESCRIPTION
1	250-1127	2	“FORKS HERE”
2	250-1141	1	“CAUTION...”
3	250-1148	1	“INSPECTION”
4	250-2058	1	“IMPORTANT...”
5	250-1143	1	“PENTALIFT”
6	250-1817	1	Specification Plate
7			
8	250-1882	2	Safety Stripe
9	250-2320	2	“DANGER Unsupported dock...”
10	250-2467	1	“DANGER Crush Hazard...”
11	250-6998	1	“IMPORTANT CONDUIT LOCATION ZONE” Note: For units with optional Pour-In Pan.
12	250-6996	1	“OPERATING INSTRUCTIONS”
13	250-6997	1	“DANGER Do not work under dock...”

NOTE: State Model # and Serial # when ordering replacement parts.

INSTALLATION INSTRUCTIONS



Do not install, operate or service this product unless you have read and fully understand the entire contents of this manual. Failure to do so may result in property damage, bodily injury or death.

NOTE: A very high level of field issues with this type of equipment can be directly attributed to improper or incomplete installation. The installation instructions and information provided for this equipment is thorough. A step by step sequence for installation is provided. All steps must be followed and completed to provide a complete installation. Incomplete or improper installations can lead to equipment malfunction and / or damage, create safety issues and void warranties. Please follow all installation and set up steps as indicated in the installation instructions and owner's manual. If you are unclear or uncertain regarding any of the steps contact your Pentalift representative for clarification. A copy of the completed steps listing with the sign off and photos of the installation as indicated at the conclusion of the installation instructions will be required prior to any Pentalift factory trouble shooting assistance.

IMPORTANT

PREPARATION PRIOR TO INSTALLATION

NOTE: Perform installation instructions in the same sequence as they are listed below. To accommodate a complete installation there is a blank space provided beside each numbered step in the installation instructions. Please check off the steps sequentially as they are completed. This will assist in confirming a complete installation.

NOTE: Shim stacks **MUST** be welded together. All shims **MUST** fully support the areas outlined in the “**Installation Instructions**” of this manual. Partial support is not sufficient and can twist and damage the equipment (see “Figure 14: Shim Stacking Method” on page 17).



Before doing any installation, maintenance, inspection or trouble shooting, barricade all areas from traffic around the work area inside (and outside if applicable) for safety and post appropriate warning signs.



Arc flash and shock hazard PPE (personal protection equipment) required. De-energize equipment before working on or inside. Do not open cover without appropriate PPE. Refer to NFPA 70E for PPE requirements. This panel may contain more than one power source. Hazardous voltage will cause severe injury or death.



Before doing any electrical work, be certain that the power is disconnected with a fused disconnect, properly tagged and locked out. Fused disconnect and lockout device (supplied and installed by others) must meet with all applicable codes and regulations. All electrical work must be performed by a qualified electrician in accordance with all applicable codes and regulations.



NEVER GO BENEATH THE DOCK LEVELER FOR ANY REASON UNLESS THE DECK AND LIP ARE PROPERLY SUPPORTED (SEE “SUPPORTING THE LEVELER FOR MAINTENANCE” on page 49) AND THE POWER IS DISCONNECTED WITH A FUSED DISCONNECT, PROPERLY TAGGED AND LOCKED OUT. IT IS THE RESPONSIBILITY OF THE OWNER TO ENSURE THAT NO LOAD OR TRAFFIC IS PLACED ON THE DECK WHILE THE MAINTENANCE STAND IS ENGAGED. THE CONSTRUCTION OF THE MAINTENANCE STAND IS INTENDED TO SUPPORT THE WEIGHT OF THE UNLOADED DOCK LEVELER ONLY.



It is the responsibility of others to ensure the proper mounting of any wall mounted equipment such as remote power units, control panels and light packages and to ensure that the mounting surface is capable of fully supporting the loads generated by the equipment.

1. Ensure pit conforms to appropriate Pentlift pit drawing.
2. Confirm pit curb angle is properly installed and meets the force requirements as shown in Figure 24, page 31.
3. Clean pit of all debris.

4. **⚠ DANGER** MAKE SURE LIFTING AND SLINGING DEVICES ARE OF SUFFICIENT CAPACITY, USED IN THE CORRECT MANNER AND ARE IN GOOD WORKING ORDER. ALL LIFTING, POSITIONING AND INSTALLATION, AS WELL AS THE BREAK-IN AND PERFORMANCE CHECK MUST BE DONE BY QUALIFIED PERSONNEL TRAINED AND EXPERIENCED IN NECESSARY SAFETY PROCEDURES.

5. **⚠ DANGER** INADEQUATE LIFTING EQUIPMENT OR PRACTICES CAN CAUSE A LIFTED LOAD TO FALL UNEXPECTEDLY. MAKE SURE THAT EYE BOLTS AND LIFTING CHAIN OR OTHER LIFTING DEVICES ARE IN GOOD CONDITION AND HAVE A RATED CAPACITY OF AT LEAST 3500 LBS FOR THE LIFTING ANGLE USED. CONFIRM THE SHIPPING WEIGHT OF THE DOCK LEVELER. IF IT IS GREATER THAN 3500 LBS THEN INCREASE THE RATED CAPACITY OF THE LIFTING DEVICE(S) TO ACCOMMODATE THE SHIPPING WEIGHT OF THE DOCK LEVELER WHEN IT IS BEING LIFTED OR PLACED INTO THE PIT. STAND CLEAR OF THE DOCK LEVELER WHEN IT IS BEING PLACED INTO THE PIT. FAILURE TO FOLLOW THIS WARNING CAN ALLOW THE DOCK LEVELER TO HIT SOMEONE, CAUSING SERIOUS INJURY OR DEATH.

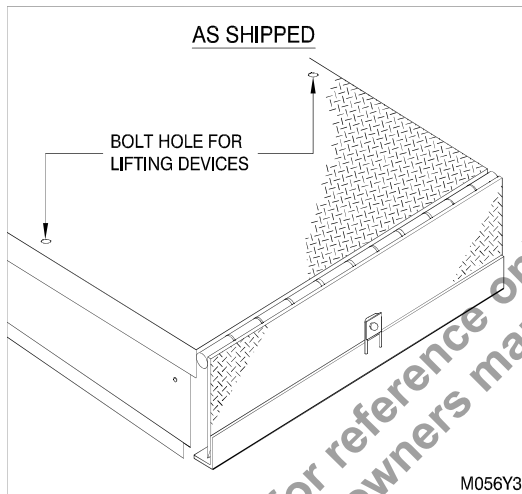

Figure 4: Bolt Hole Locations

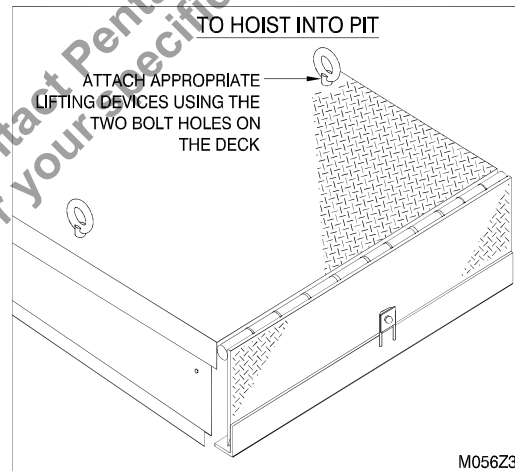

Figure 5: Attach Lifting Devices

6. Install an appropriate lifting device into the two supplied holes and nuts (5/8"-11 UNC) in the dock leveler (See "Figure 5: Attach Lifting Devices" on page 9).
7. For units with a nominal depth of 20" being installed into a deeper pit, proceed to the "INSTALLATION USING SHIM KIT" on page 18.
8. Confirm that all steps of the installation instructions have been completed. Fill out the following information.

Installer Name (Print)

Installer Signature

Date Installation Completed

INSTALLING LEVELER INTO PIT

1. Hoist leveler into pit with appropriate chain and lifting devices (See “Figure 6: Hoist Leveler with Chain” on page 11) and position the leveler into the pit opening. The dock leveler must not be lifted in any other manner.

Note: Ensure temporary wire is accessible through front of dock leveler. (“Figure 7a: Temporary Power Cord & Plug” on page 12)
2. Ensure 1" clearance is maintained between the side of leveler platform and the side pit wall and that rear angle of dock is tight with rear curb angle.
3. Remove the lifting devices. **Remove** the front shipping bolt and washer. (“Figure 6: Hoist Leveler with Chain” on page 11)
4. Raise dock leveler by plugging dock into power supply with the supplied power cord and plug assembly (see “Figure 7a: Temporary Power Cord & Plug” on page 12) .

DANGER

- WIRING MUST BE DONE BY A QUALIFIED ELECTRICIAN.
- ALWAYS USE APPROPRIATE LOCK-OUT PROCEDURES DURING ANY ELECTRICAL INSTALLATIONS.
- ASSURE SUPPLY VOLTAGE IS CORRECT.
- ON 3 PHASE UNITS ASSURE PHASE POLARITY IS CORRECT.
- ALWAYS OBSERVE ALL APPLICABLE ELECTRICAL CODES.

NOTE: The power cord & plug assembly supplied with the dock leveler is intended to be used for raising the deck for the initial installation only. Once the maintenance stand is in position, the supplied power cord & plug assembly is to be altered as follows. Permanent wiring must be installed immediately. Install the junction box with a standard 115/1/60 female receptacle in the dock leveler pit as per “Figure 7b: Power Cord & Junction Box” on page 12. Use the provided power cord running from the blower assembly to connect the blower to the junction box. Route the power cord so that it does not come in the path of any of the moving parts of the dock leveler. Once the power cord is properly routed to the junction box, cut any access off and reinstall the supplied 115/1/60 plug that was provided on the cord. Discard the access material that was cut off. Run the appropriate electrical wires from the control panel to the receptacle box through the conduit. (see “Figure 8: Control Panel & Placard Location” on page 14).

NOTE: The supplied power cord & plug assembly shall be connected only if they meet the requirements of the applicable local electrical codes. If they do not, the electrician shall rewire to meet all applicable codes prior to applying any electrical power.

NOTE: The supplied power cord must be wired through a push-button control in order to raise the deck. Never wire the supplied power cord directly to a power supply.

NOTE: Jumper wires must be added between terminal 3 and A2 of the contactor and between A1 of the contactor and terminal 4 of the push button (see “Figure 65: Electrical Schematics- Basic Model (Jog Start)” on page 68).

NOTE: Do not push & hold the raise button after the leveler has fully raised and lip has extended, doing so may result in damage to the air bag and/or dock leveler.

5. ___ Once the deck reaches its maximum raised height with the lip fully extended, support the dock leveler as instructed in the "SUPPORTING THE LEVELER FOR MAINTENANCE" on page 49.

CAUTION

The maintenance stand of this dock leveler is designed for use only when the dock leveler is securely welded into the dock leveler pit. Use of the stand is not recommended if the dock leveler is not securely welded into the pit (see "Figure 13: Back Angle Weld of Dock Leveler" on page 16). To support the dock leveler at times when installation welding is not in place, utilize the auxiliary maintenance stand (see "Figure 59.1: Supporting the Dock Leveler with the Auxiliary Maintenance Stand" on page 51) that supports the dock leveler more centered on the dock leveler width.

6. ___ Support the lower half of the toe guard and remove the self tapping screw which holds it in the shipping position. **Carefully** lower the toe guard and avoid pinch points. (see "Figure 6: Hoist Leveler with Chain" on page 11)
7. ___ Both the Lip chain and Deck stop chain have been tie wrapped for shipping purpose. The raising of the dock leveler should break the tie wraps free. Visually ensure that all tie wraps have broken free and are removed from the chains. Failure to do so will impede the proper functioning of the dock leveler (see "Figure 7c: Lip Chain tied up for shipping" on page 13 and "Figure 7d: Deck stop chain tied up for shipping" on page 13).

DANGER

DO NOT DISCONNECT THE TEMPORARY POWER SUPPLY UNTIL MAINTENANCE STAND IS IN POSITION. DECK WILL AUTOMATICALLY LOWER WHEN POWER IS DISCONNECTED OR PUSH BUTTON IS RELEASED. ONCE MAINTENANCE STAND IS SECURELY IN PLACE, DISCONNECT TEMPORARY POWER SUPPLY.

STAY CLEAR OF THE EQUIPMENT'S OPERATING PATH AT ALL TIMES.

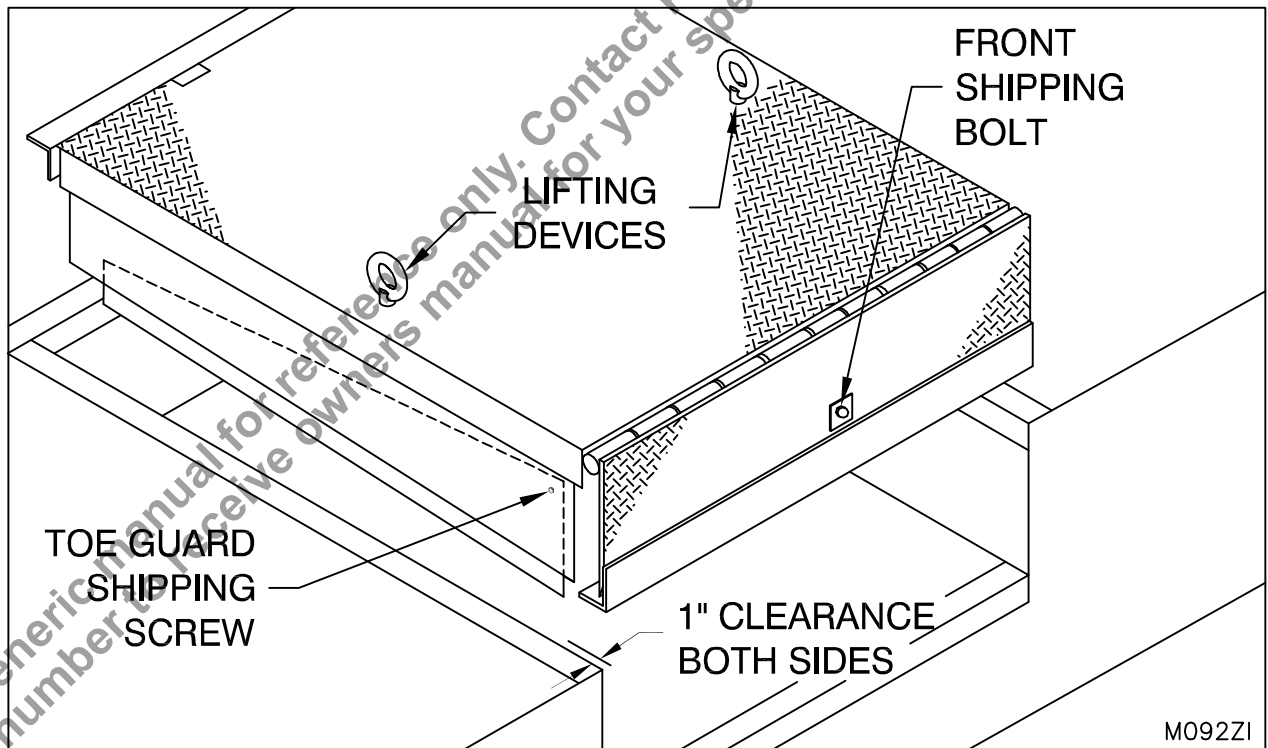

Figure 6: Hoist Leveler with Chain

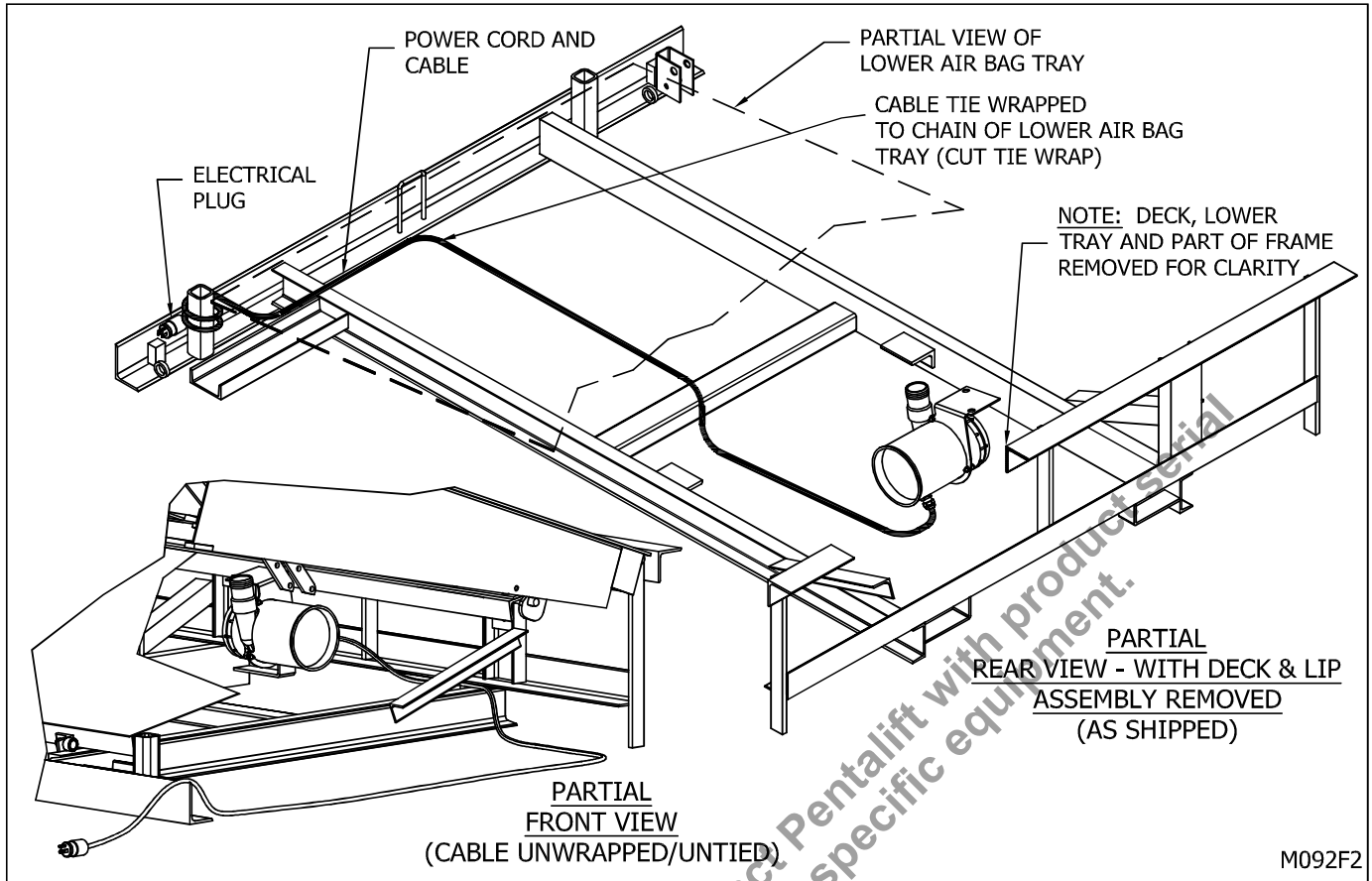

Figure 7a: Temporary Power Cord & Plug

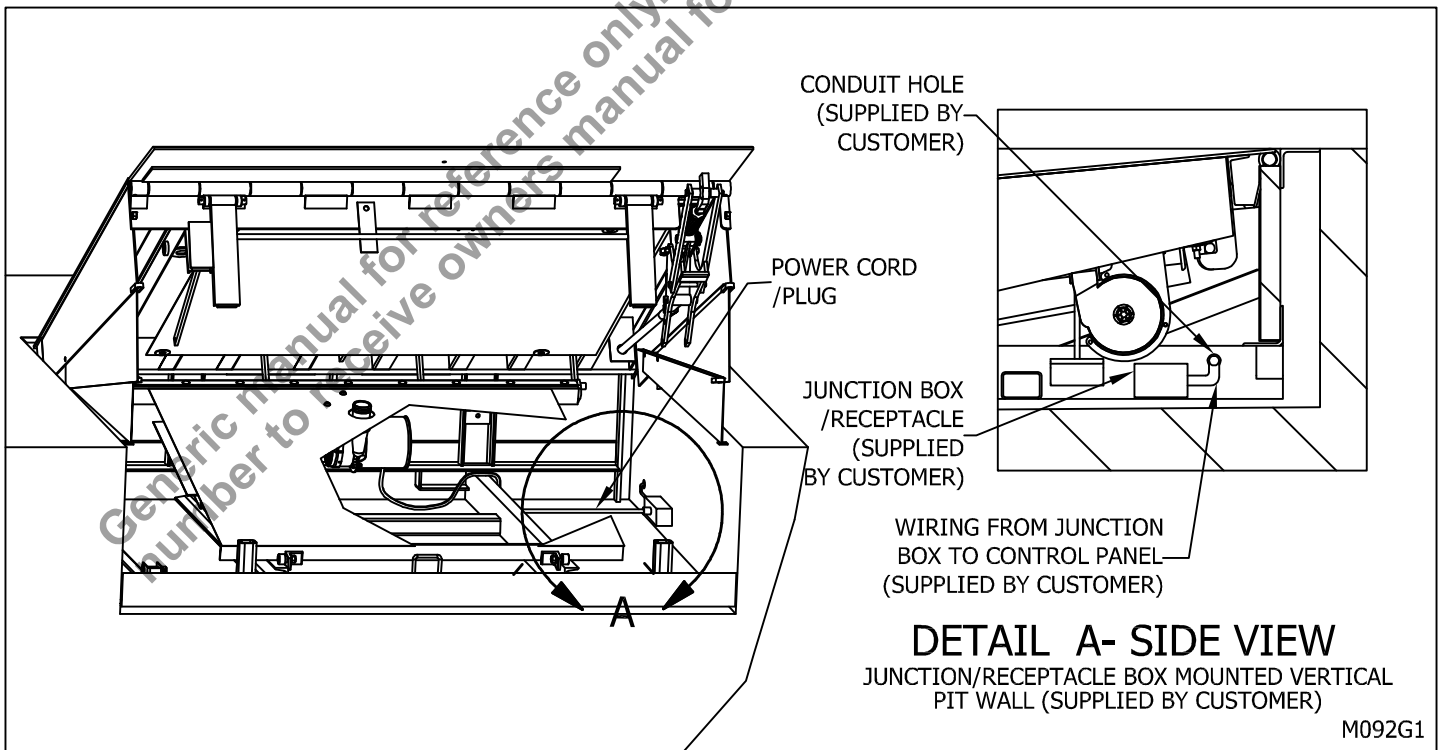

Figure 7b: Power Cord & Junction Box

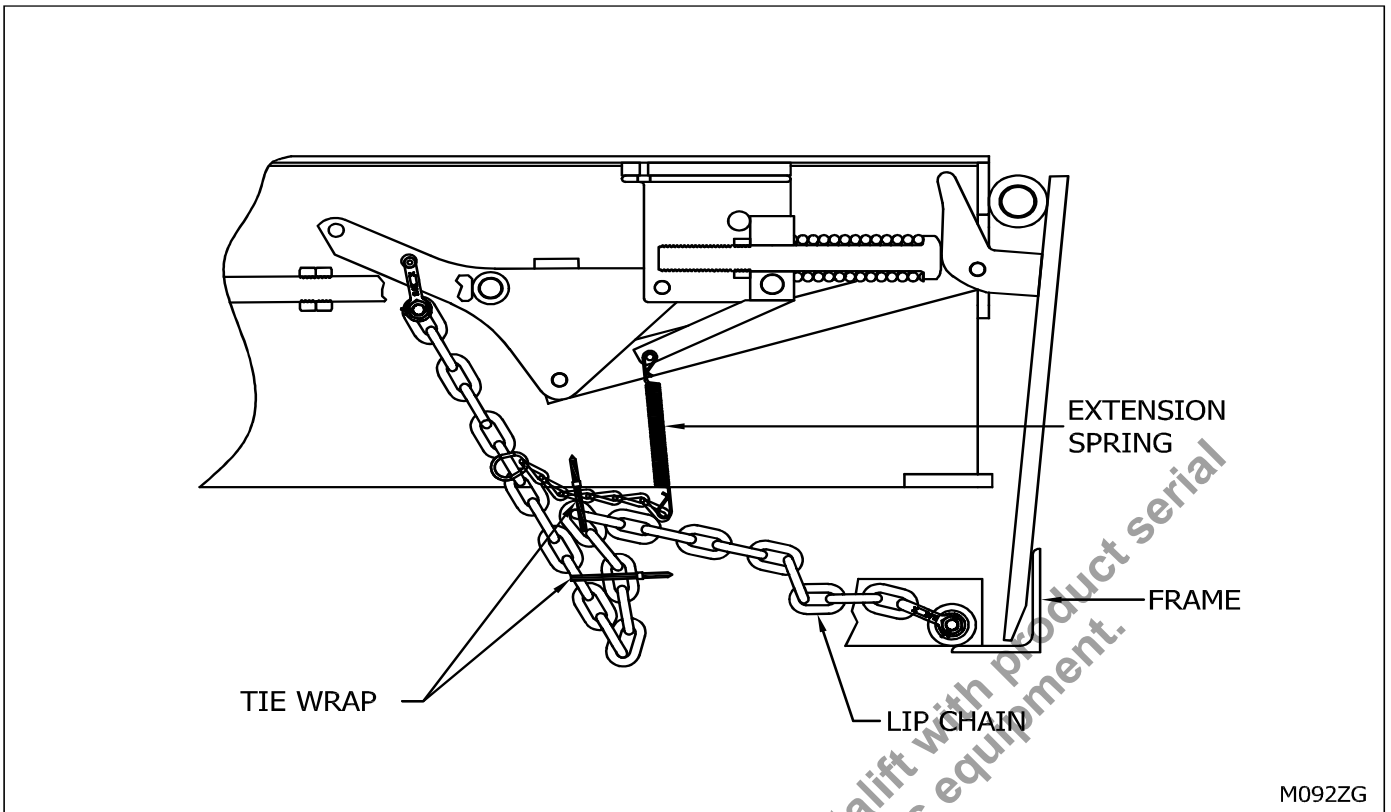

Figure 7c: Lip Chain tied up for shipping

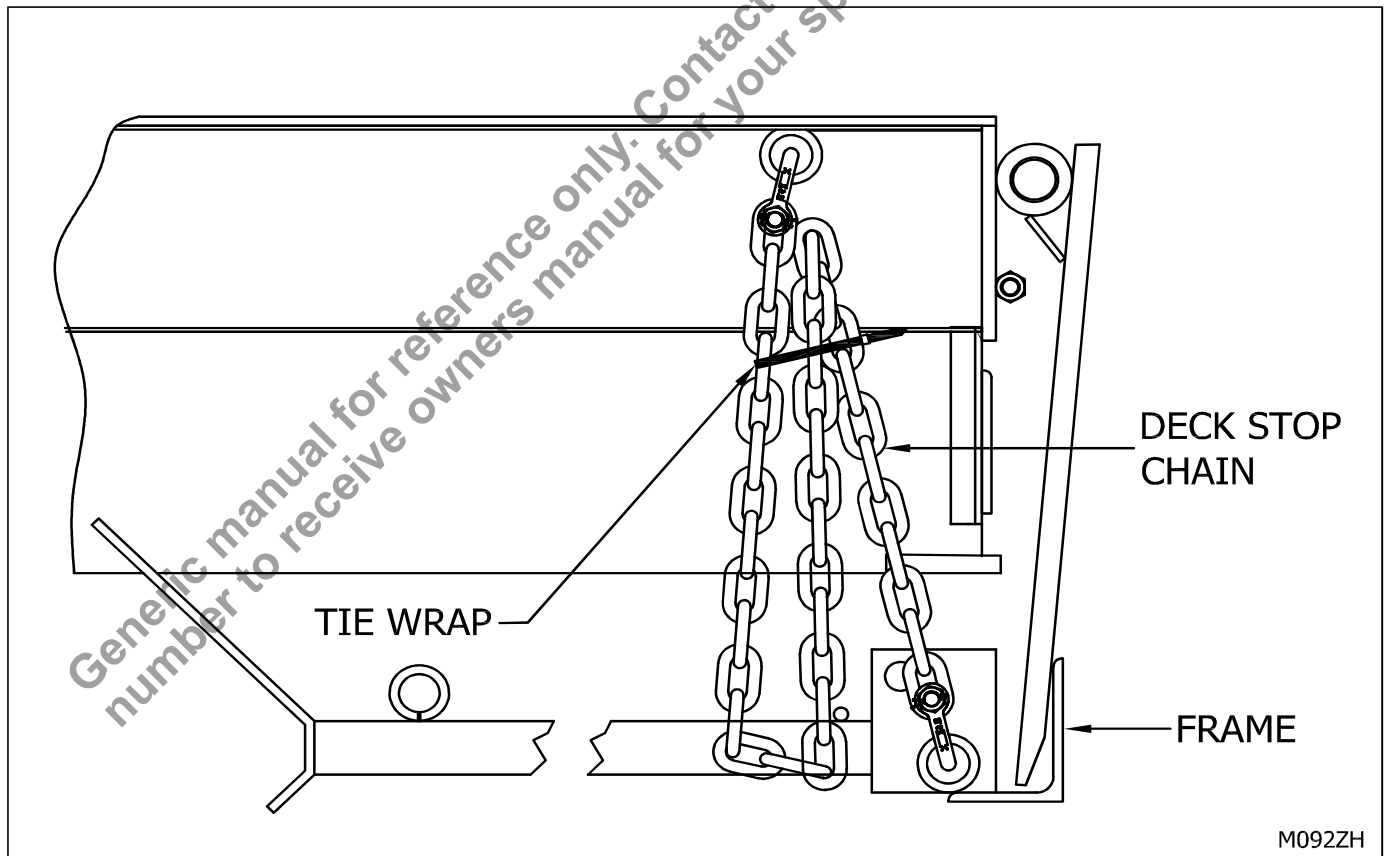

Figure 7d: Deck stop chain tied up for shipping

8. ___ Mount the control panel and the supplied instruction placard in an appropriate location. ("Figure 8: Control Panel & Placard Location" on page 14).
 9. ___ Locate a junction box with a standard 115/1/60 female receptacle (supplied by customer) on the vertical pit wall with the top of box lower than the conduit hole and horizontally between the conduit hole and pit floor (see "Figure 7b: Power Cord & Junction Box" on page 12).
 10. ___ Use the provided power cord running from the blower assembly to connect the blower to the junction box. Route the power cord so that it does not come in the path of any of the moving parts of the dock leveler. Once the power cord is properly routed to the junction box, cut any access off and reinstall the supplied 115/1/60 plug that was provided on the cord. Discard the access material that was cut off.
 11. ___ Run the appropriate electrical wires from the control panel to the receptacle box through the conduit.
 12. ___ Jumper wires must be added between terminal 3 and A2 of the contactor and between A1 of the contactor and terminal 4 of the push button (see "Figure 65: Electrical Schematics- Basic Model (Jog Start)" on page 68).
 13. ___ Connect main power supply to the control panel.
- NOTE:** Blower unit requires full voltage at motor. Wire size should be sufficiently sized to prevent line voltage drop when motor is under load. See note on chart ("ELECTRICAL REFERENCE CHART" on page 29)
14. ___ Confirm that all steps of the installation instructions have been completed. Fill out the following information.

Installer Name (Print)

Installer Signature

Date Installation Completed

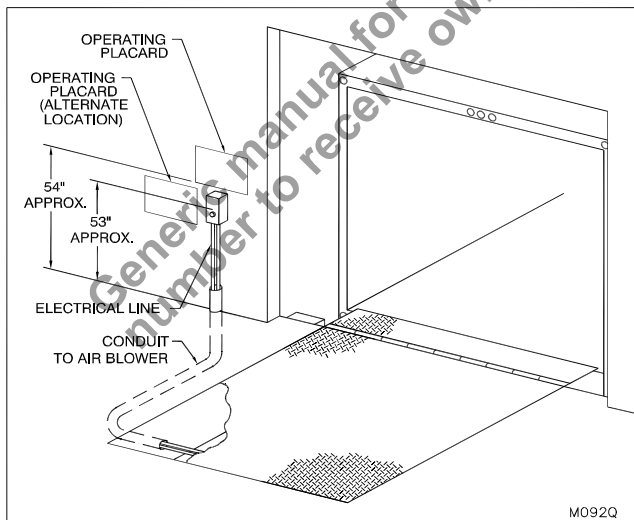

Figure 8: Control Panel & Placard Location

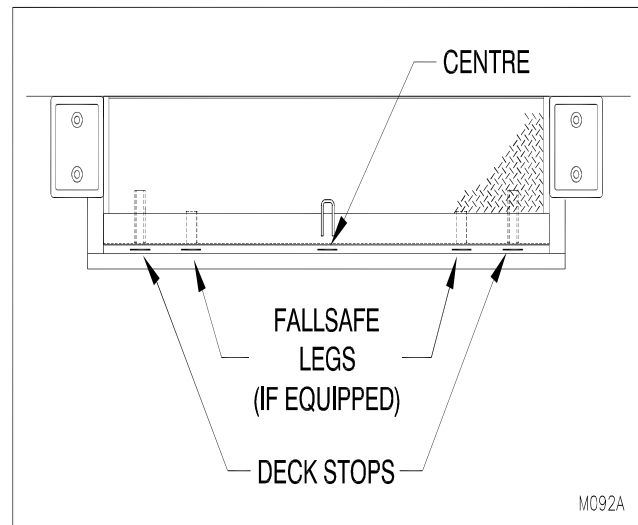

Figure 11: Dock Leveler Front Shims

LEVELING INSTRUCTIONS

NOTE: Welding blanket must be placed over air bag during installation to protect the airbag. Welding, torching or griding heat sources can cause damage the air bag.

1. ___ Place shims of minimum length and width of 3" by 4" and a minimum thickness of 14 gauge under rear frame until top rear of dock leveler is flush with rear curb angle. (See "Figure 12: Dock Leveler Rear Shims" on page 16) Tack weld into position.

NOTE: All shim stacks **MUST** be welded together. All shims **MUST** fully support the areas outlined in the "Installation Instructions" of this manual. Partial support is not sufficient and can twist and damage the equipment (see "Figure 14: Shim Stacking Method" on page 17).

2. ___ Lower dock leveler to the stored position and shim front frame under the two deck stops and in center of dock leveler until the deck is flush with the top of the front curb angle and the floor. If the dock comes with the mechanical fallsafe option then shim as indicated (See "Figure 11: Dock Leveler Front Shims" on page 14) Tack weld into position.
3. ___ Confirm that the back angle of dock leveler is firmly against and flush with the top of the rear curb angle and that the dock leveler remains square in the pit before continuing.
4. ___ Make sure the rear pit curb angle is straight and level prior to installation. Make sure the dock leveler rear frame angle (or flat bar) is straight to match the rear pit curb angle. If the rear frame angle (or flat bar) is not straight then force the angle back to match the straight rear pit curb angle using a wedging device between the frame angle and the back of the deck as shown in "Figure 15: Wedging the Rear Frame Angle to the Rear Pit Curb Angle" on page 16. Tack weld the straightened angle to the rear pit curb angle. Repeat the wedging process as required over the length for the rear frame angle.
5. ___ Weld back angle of dock leveler to rear curb angle as shown in "Figure 13: Back Angle Weld of Dock Leveler" on page 16, using the welding reference and notes on page 28 as a guide.
6. ___ Raise the dock leveler to its maximum height and support in accordance with the "SUPPORTING THE LEVELER FOR MAINTENANCE" on page 49.

NOTE: All shim stacks **MUST** be welded together. All shims **MUST** fully support the areas outlined in the "Installation Instructions" of this manual. Partial support is not sufficient and can twist and damage the equipment (see "Figure 14: Shim Stacking Method" on page 17).

7. ___ Finish welding the front (3" long welds) and rear shim stacks to the frame of the dock leveler.
8. ___ Weld or bolt bumpers in place.
9. ___ Paint welds using Tremclad High Performance Rust Enamel (Gloss Dark Machine Grey).
10. ___ Mount Dock Leveler warning and operating instructions placard close to the Dock Leveler in a location that assures an unobstructed view and Complete Legibility at all times.
11. ___ Lubricate and test in accordance with the "BREAK-IN AND PERFORMANCE CHECK" on page 45.
12. ___ Confirm that all steps of the installation instructions have been completed. Fill out the following information.

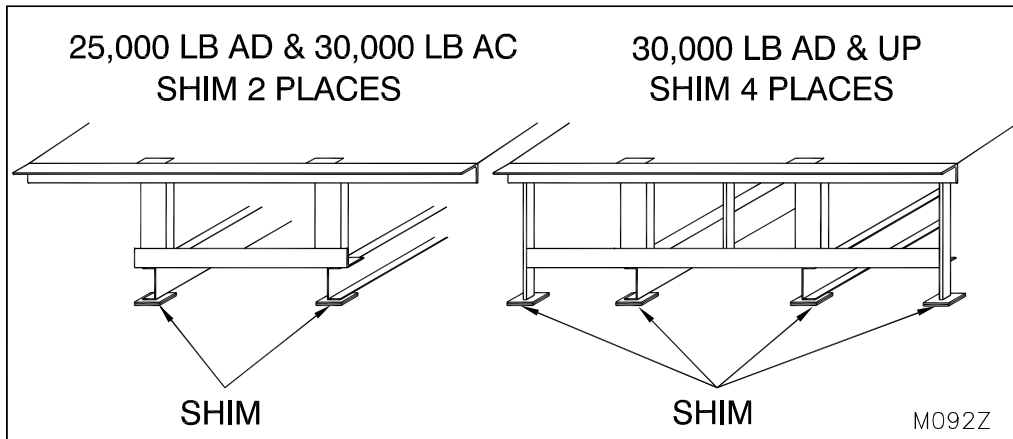

Figure 12: Dock Leveler Rear Shims

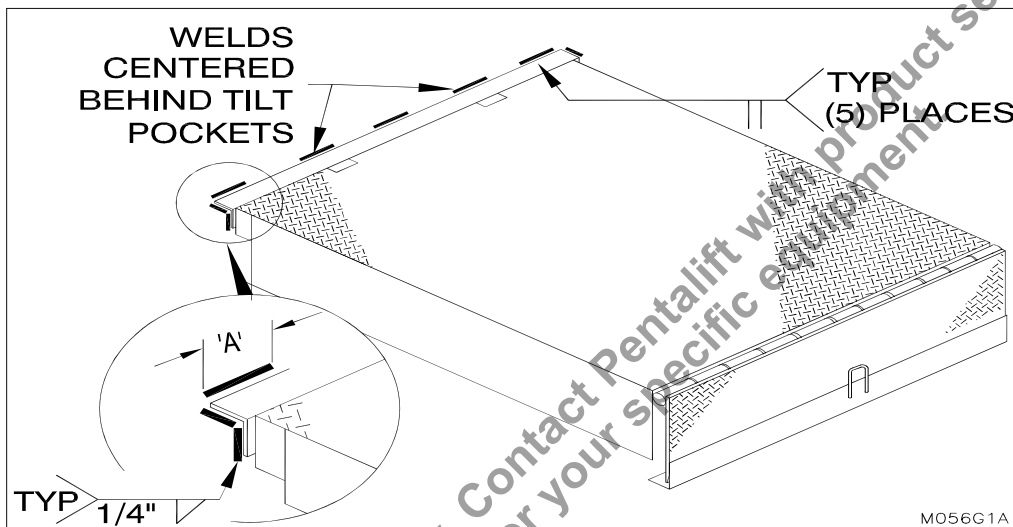

Figure 13: Back Angle Weld of Dock Leveler

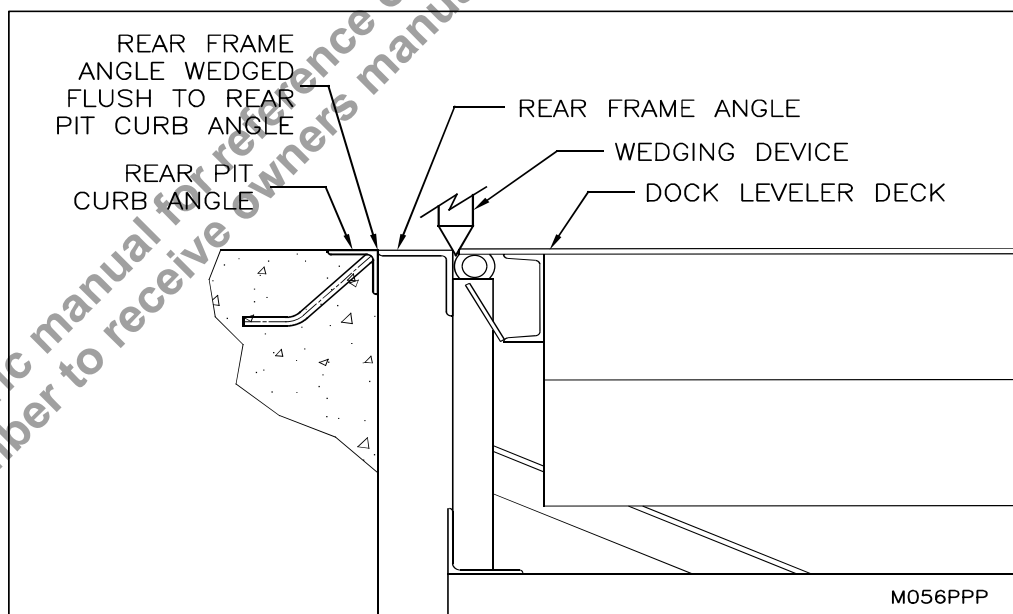

Figure 15: Wedging the Rear Frame Angle to the Rear Pit Curb Angle

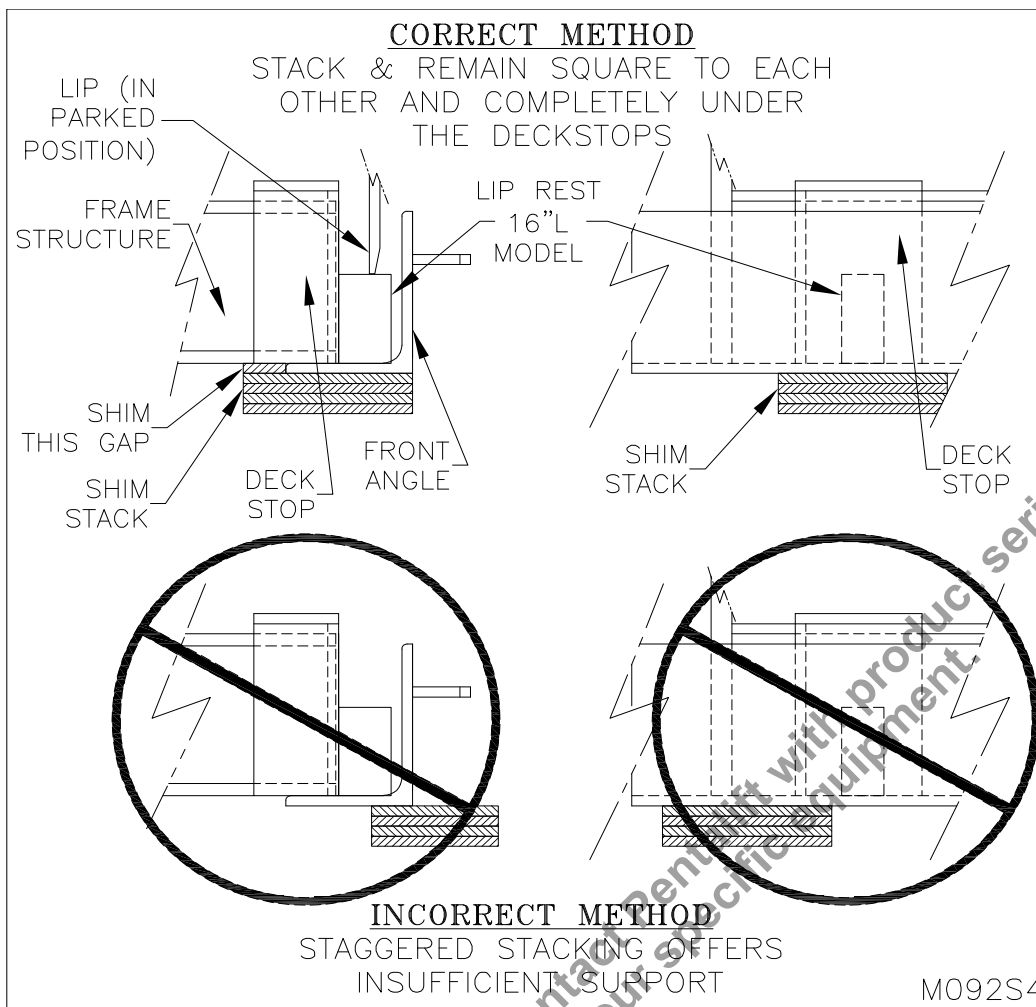

Figure 14: Shim Stacking Method

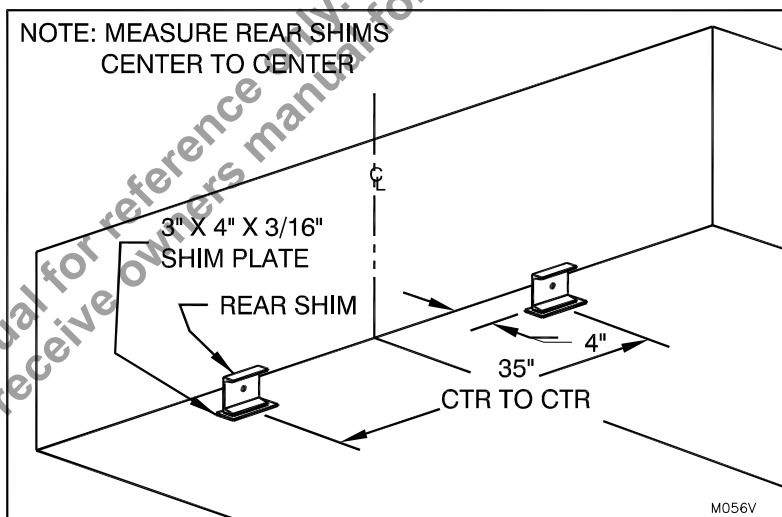

Figure 19: Rear Shim Location(4\"/>

Installer Name (Print)

Installer Signature

Date Installation Completed

INSTALLATION USING SHIM KIT

For units with a nominal depth of 20" being installed into a deeper pit, it will be necessary to install a shim kit. Shim kits are available in standard heights of 1", 2", 3" and 4".

NOTE: All shim stacks **MUST** be welded together. All shims **MUST** fully support the areas outlined in the "Installation Instructions" of this manual. Partial support is not sufficient and can twist and damage the equipment (see "Figure 14: Shim Stacking Method" on page 17).

SELF CONTAINED POWER UNIT

- For 3" or 4" shim kits, weld two rear shims (see Table A) to a single shim plate each (3" x 4" x minimum ASTMA-36 or CSA G40.21 supplied by others) as shown in "Figure 22: Rear Shim (4" Shim Kit Shown)" on page 18. This step adds stability to the shims while installing the dock. This step is not required for 1" or 2" shim kits as the blocks are sufficiently stable as supplied.

Table A - Rear Shims	
4" Shim Kit	C4 Channel x 25 3/8" or 39" Long
3" Shim Kit	C3 Channel x 4" Long
2" Shim Kit	2" x 3" x 3/16" Rect. Tube x 4" Long
1" Shim Kit	1" x 3" Flat Bar x 4" Long

Note: On 25,000 lb and 30,000 lb AC models, there will be two rear shims; on 30,000 lb AD models and higher capacities, there will be four. Do not weld the outer rear shims (30,000 lb AD models and higher capacities) at this time.

- Place the front-angle shim assembly into the pit at the front edge, centered across the dock leveler and pit width. When the front-angle shim is constructed of C-channel (3" & 4" shim kits) ensure the short pieces (12" long) on each end are installed toward the inside of the pit. See "Figure 24: Installation Shims (4" Shim Kit Channel Shim Shown)" on page 22.
- Place the two rear shims with welded-on shim plate at the rear of the pit, 35" center to center and 4" from the rear pit wall. ("Figure 19: Rear Shim Location(4" High Rear Shim Shown)" on page 17)

⚠ DANGER NEVER GO BENEATH THE DOCK LEVELER UNLESS IT IS PROPERLY SUPPORTED ON THE FRONT SHIMS, THE REAR ANGLE IS SECURELY WELDED AND THE MAINTENANCE STAND IS ENGAGED.

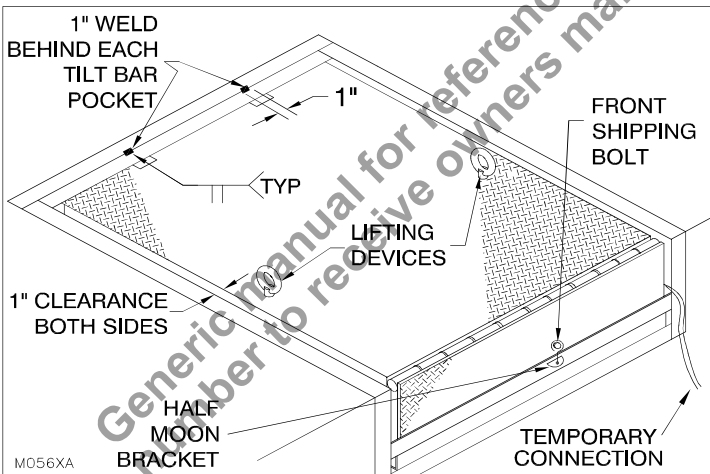

Figure 21: Installing Leveler into Pit

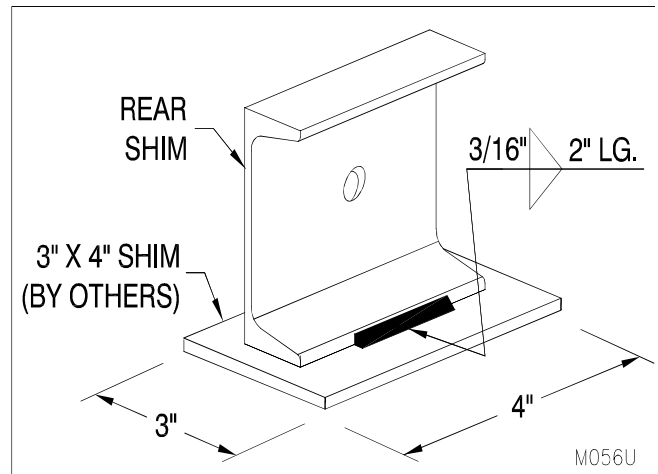

Figure 22: Rear Shim (4" Shim Kit Shown)

4. ___ Hoist leveler into pit with chain using only appropriate lifting devices (“Figure 6: Hoist Leveler with Chain” on page 11) and position the leveler into the pit opening. Note: Assure temporary wire is accessible through front of dock leveler. (“Figure 21: Installing Leveler into Pit” on page 18).
5. ___ Ensure 1” clearance is maintained between the side of leveler platform and the side pit wall and that the rear angle of the dock is firmly against the rear curb angle. (“Figure 6: Hoist Leveler with Chain” on page 11)
6. ___ Confirm that the back angle of the dock leveler is firmly against and flush with the top of the rear curb angle and that the dock leveler has remained square in the pit before continuing.
7. ___ Weld the rear angle of the dock leveler to the rear curb angle, 1” wide butt weld, at the location of each tilt bar pocket (2 places). “Figure 21: Installing Leveler into Pit” on page 18.
8. ___ Lower the dock leveler until the front angle of the dock leveler rests on the front-angle shim. Ensure the front-angle shim assembly is flush with the front angle of the dock leveler frame. “Figure 24: Installation Shims (4” Shim Kit Channel Shim Shown)” on page 22.
9. ___ Weld the front-angle shim to the dock leveler frame.
10. ___ Remove the top shipping bolts and lifting devices. Remove the front shipping bolt (“Figure 6: Hoist Leveler with Chain” on page 11).
11. ___ Connect the temporary wire from the power supply to the temporary wire supplied with the dock leveler. (“Figure 7a: Temporary Power Cord & Plug” on page 12)

⚠ DANGER

- **WIRING MUST BE DONE BY A QUALIFIED ELECTRICIAN.**
- **ALWAYS USE APPROPRIATE LOCK-OUT PROCEDURES DURING ANY ELECTRICAL INSTALLATIONS.**
- **ASSURE SUPPLY VOLTAGE IS CORRECT.**
- **ON 3 PHASE UNITS ASSURE PHASE POLARITY IS CORRECT.**
- **ALWAYS OBSERVE ALL APPLICABLE ELECTRICAL CODES.**

NOTE: The power cord & plug assembly supplied with the dock leveler is intended to be used for raising the deck for the initial installation only. Once the maintenance stand is in position, the supplied power cord & plug assembly is to be altered as follows. Permanent wiring must be installed immediately. Install the junction box with a standard 115/1/60 female receptacle in the dock leveler pit as per “Figure 7b: Power Cord & Junction Box” on page 12. Use the provided power cord running from the blower assembly to connect the blower to the junction box. Route the power cord so that it does not come in the path of any of the moving parts of the dock leveler. Once the power cord is properly routed to the junction box, cut any access off and reinstall the supplied 115/1/60 plug that was provided on the cord. Discard the access material that was cut off. Run the appropriate electrical wires from the control panel to the receptacle box through the conduit. (see “Figure 8: Control Panel & Placard Location” on page 14).

NOTE: The supplied power cord & plug assembly shall be connected only if they meet the requirements of the applicable local electrical codes. If they do not, the electrician shall rewire to meet all applicable codes prior to applying any electrical power.

NOTE: The supplied power cord must be wired through a push-button control in order to raise the deck. Never wire the supplied power cord directly to a power supply.

NOTE: Jumper wires must be added between terminal 3 and A2 of the contactor and between A1 of the contactor and terminal 4 of the push button (see “Figure 65: Electrical Schematics- Basic Model (Jog Start)” on page 68).

NOTE: Do not push & hold the raise button after the leveler has fully raised and lip has extended, doing so may result in damage to the air bag and/or dock leveler.

12. ___ Cycle the dock leveler through the raise and lower functions several times to re-align after shipping.
13. ___ Return the dock to the stored position.
14. ___ Add shims (3" x 4" x required thickness) to increase the front height of the dock until the deck plate is flush with the dock height (or at desired final level). Ensure shims are located beneath the front-angle shim at the location of the two deck stops as well as at the center of the front angle. (See "Figure 24: Installation Shims (4" Shim Kit Channel Shim Shown)" on page 22) All shims are to be minimum ASTM A-36 or CSA G40.21 material.
15. ___ Weld all shims in the stack to the front-angle shim, the front pit curb angle, and each other (3" long weld).
16. ___ Complete welding the back angle of the dock leveler to the rear pit curb angle as shown in "Figure 13: Back Angle Weld of Dock Leveler" on page 16.
17. ___ Raise the deck to its maximum raised height with the lip fully extended and support the dock leveler as instructed in the "SUPPORTING THE LEVELER FOR MAINTENANCE" on page 49.



NEVER GO BENEATH THE DOCK LEVELER UNLESS IT IS PROPERLY SUPPORTED ON THE FRONT SHIMS, THE REAR ANGLE IS SECURELY WELDED AND THE MAINTENANCE STAND IS ENGAGED.

18. ___ Add shims (3" x 4" x required thickness) between the pit floor and the rear shim to close any gap and fully support the rear of the dock. Fully weld the two rear shims to the frame of the dock leveler and all shim plates in the stack to each other as well as to the rear shim.
19. ___ For 30,000 AD models and higher capacities, weld the additional two rear shims to the outside support bar of the frame as shown in "Figure 23: 30,000 lb + Outer Rear Shims (4" Shim Kit Channel Shim Shown)" on page 20 and shim until they are fully supported. Weld all of the shims to each other as well as to the dock leveler frame.

Table A - Rear Shims	
4" Shim Kit	C4 Channel x 25 3/8" or 39" Long
3" Shim Kit	C3 Channel x 4" Long
2" Shim Kit	2" x 3" x 3/16" Rect. Tube x 4" Long
1" Shim Kit	1" x 3" Flat Bar x 4" Long

NOTE: For 4" Shim Kit, on 30,000 lb AD models and higher capacities, there will be two rear shims.

NOTE: For 1" to 3" Shim Kits, on 30,000 lb AD models and higher capacities, there will be four rear shims.

NOTE: All shim stacks must be welded together.

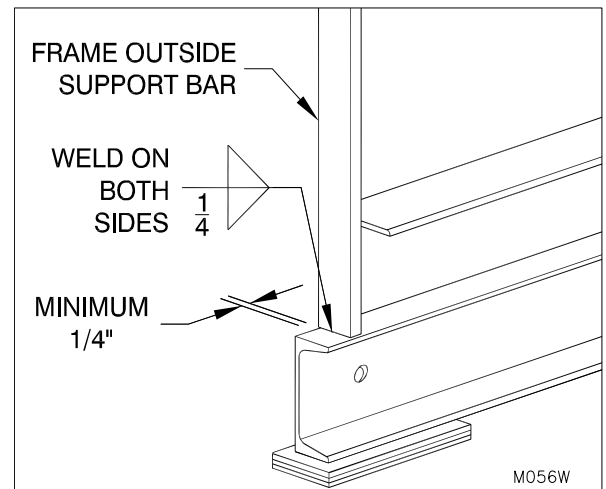

Figure 23: 30,000 lb + Outer Rear Shims (4" Shim Kit Channel Shim Shown)

20. ___ Place additional shimstack under the frame beam to support air bag roller tray (see "Figure 24: Installation Shims (4" Shim Kit Channel Shim Shown)" on page 22).
21. ___ Support the lower half of the toe guard and remove the self tapping screw which holds it in the shipping position. Carefully lower the toe guard and avoid pinch points. ("Figure 6: Hoist Leveler with Chain" on page 11)
22. ___ Mount the control panel and supplied instruction placard in an appropriate location. ("Figure 8: Control Panel & Placard Location" on page 14)



DO NOT DISCONNECT THE TEMPORARY POWER SUPPLY UNTIL MAINTENANCE STAND IS IN POSITION. DECK WILL AUTOMATICALLY LOWER WHEN POWER IS DISCONNECTED OR PUSH BUTTON IS RELEASED. ONCE MAINTENANCE STAND IS SECURELY IN PLACE, DISCONNECT TEMPORARY POWER SUPPLY. STAY CLEAR OF THE EQUIPMENT'S OPERATING PATH AT ALL TIMES.

- 25. Locate a junction box with a standard 115/1/60 female receptacle (supplied by customer) on the vertical pit wall with the top of box lower than the conduit hole and horizontally between the conduit hole and pit floor (see "Figure 7b: Power Cord & Junction Box" on page 12).
 - 26. Use the provided power cord running from the blower assembly to connect the blower to the junction box. Route the power cord so that it does not come in the path of any of the moving parts of the dock leveler. Once the power cord is properly routed to the junction box, cut any access off and reinstall the supplied 115/1/60 plug that was provided on the cord. Discard the access material that was cut off.
 - 27. Run the appropriate electrical wires from the control panel to the receptacle box through the conduit.
 - 28. Jumper wires must be added between terminal 3 and A2 of the contactor and between A1 of the contactor and terminal 4 of the push button (see "Figure 65: Electrical Schematics- Basic Model (Jog Start)" on page 68).
 - 29. Connect main power supply to control panel.
- NOTE:** Power unit requires full voltage at motor. Wire size should be sufficiently sized to prevent line voltage drop when motor is under load. ("ELECTRICAL REFERENCE CHART" on page 29)
- 30. Weld or bolt bumpers in place.
 - 31. Clean and paint the welds using Tremclad High Performance Rust Enamel (Gloss Dark Machine Grey).
 - 32. Touch up any scratches, abrasions or paint damage that exist. Pentalift standard gray paint matches with Tremclad High Performance Rust Enamel (Gloss Dark Machine Grey).
 - 33. Mount dock leveler warning and operating instructions placard close to the Dock Leveler in a location that assures an unobstructed view and Complete Legibility at all times.
 - 34. Lubricate and test in accordance with the "BREAK-IN AND PERFORMANCE CHECK" on page 45.
 - 35. Confirm that all steps of the installation instructions have been completed. Fill out the following information.

Installer Name (Print)

Installer Signature

Date Installation Completed

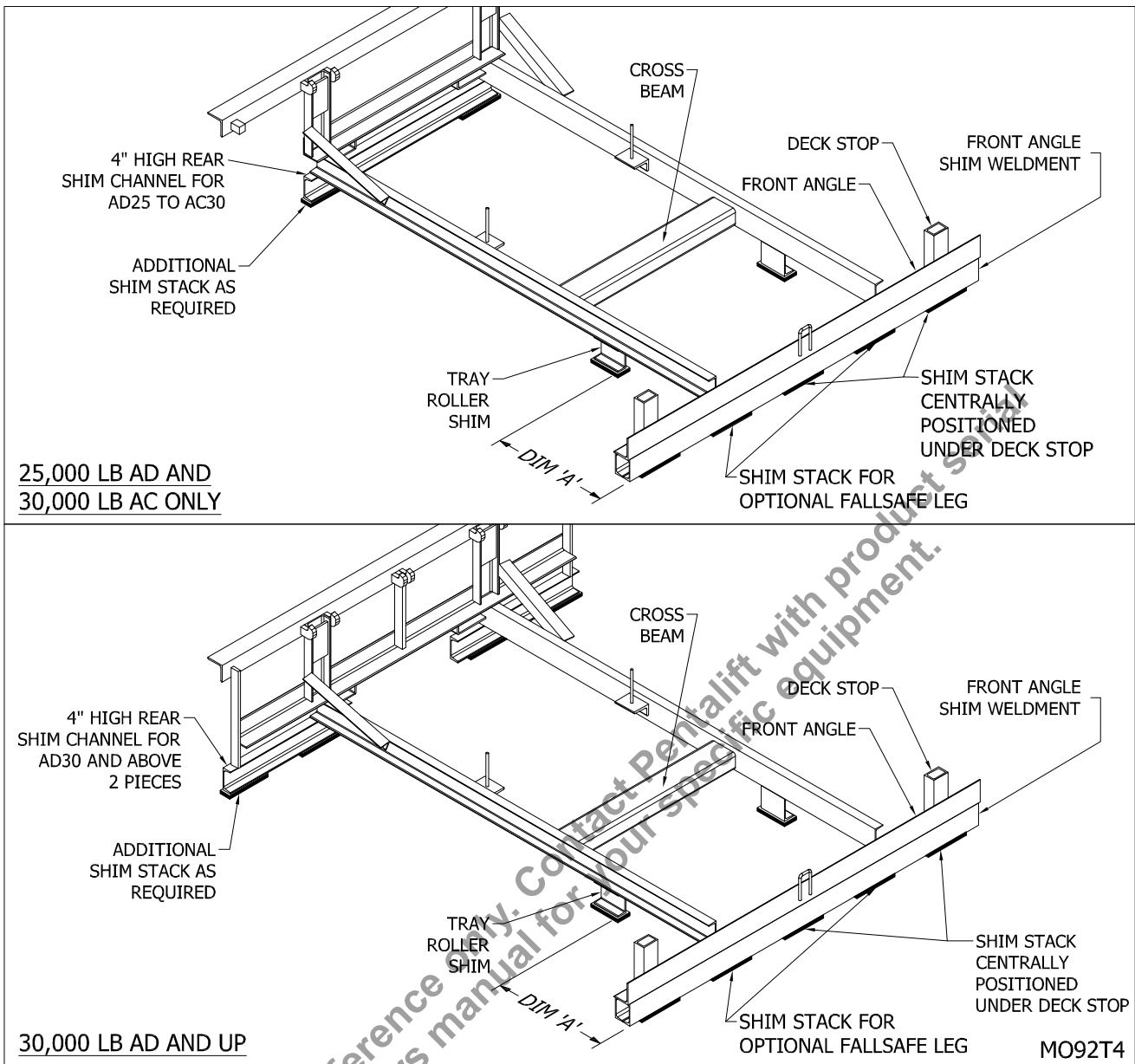

Figure 24: Installation Shims (4" Shim Kit Channel Shim Shown)

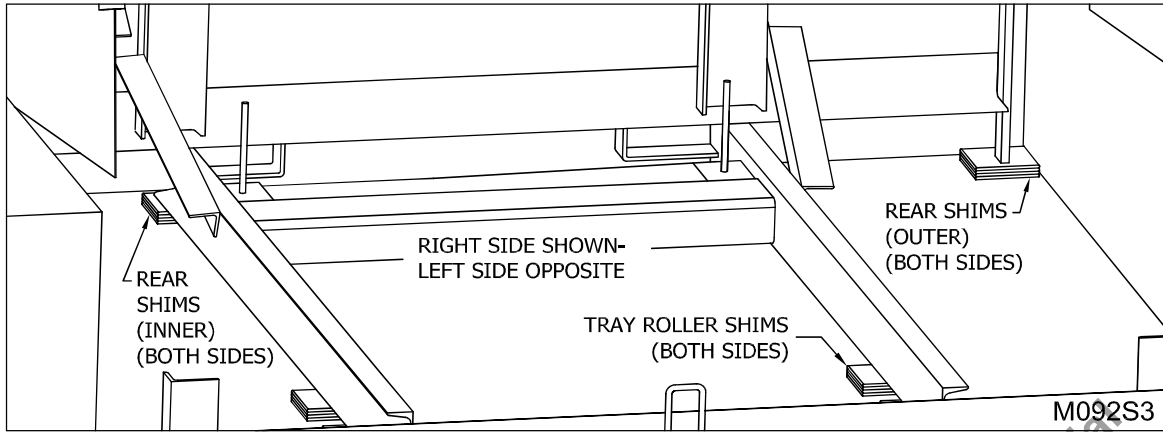

Figure 24a: Rear & Roller Shims (4" Shim Kit Shown)

Shimming is required underneath the frame beam, and positioned under the air bag tray's rollers. The location of the tray roller shim is represented as DIM 'A' as shown in "Figure 24: Installation Shims (4" Shim Kit Channel Shim Shown)" on page 22 and "Figure 24a: Rear & Roller Shims (4" Shim Kit Shown)" on page 23. This dimension is measured from the front edge of the front angle to the front edge of the shim. For 8 ft. long models DIM 'A' is to be 26 7/8" and for 6 ft. long models DIM 'A' is to be 3 3/16".

Generic manual for reference only. Contact Pentalift with product serial number to receive owners manual for your specific equipment.

INSTALLATION USING FILLER PLATE

INSTALLATION INSTRUCTIONS FOR 3-INCH FILLER PLATE

1. Before installing the filler plate and dock leveler, read the "INSTALLATION INSTRUCTIONS" section of the owner's manual on page 8.
2. Position the 3 inch square tube against the rear curb angle and flush to the top surface of the curb angle.
3. Weld the ends of the square tubing to the side curb angle (see "Figure 25: Welding the 3 X 3 Square Tubing to the Curb Angles" on page 24. Add vertical welds at the ends of the tube between tube surface and side curb angle surface.
4. Note the centerline positions of the tilt bar pockets on the dock leveler.
5. Transfer the centerline positions to the square tube.
6. Weld 1 inch butt weld at the mark off locations on the square tube
7. Based on the dock leveler's rated capacity, see "WELDING REFERENCE INFORMATION" on page 28 to determine the length of the weld for dimension "A".
8. Refer to the rest of the installation section of the owner's manual to install the dock leveler.
9. Confirm that all steps of the installation instructions have been completed. Fill out the following information.

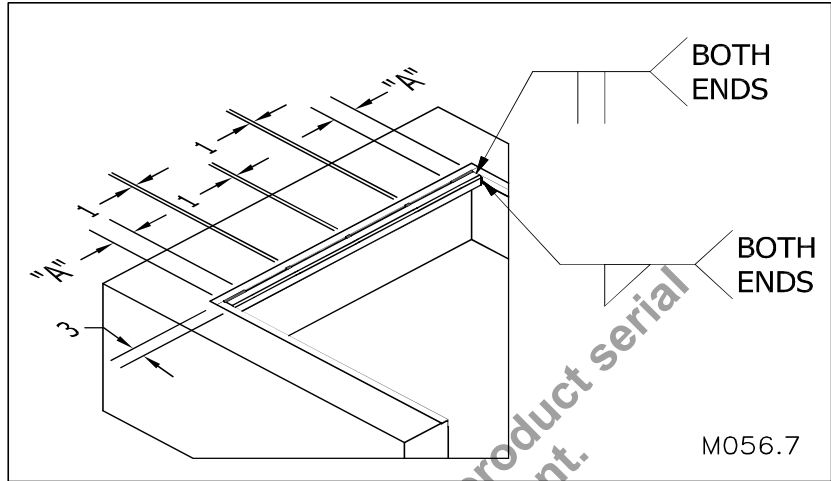

Figure 25: Welding the 3 X 3 Square Tubing to the Curb Angles

Installer Name (Print)

Installer Signature

Date Installation Completed

INSTALLATION INSTRUCTIONS FOR 4-INCH FILLER PLATE

1. Before installing the filler plate and dock leveler, read the "INSTALLATION INSTRUCTIONS" section of the owner's manual on page 8.

2. Position the 4 X 3 inch rectangular tube against the rear curb angle and flush to the top surface of the curb angle.

3. Weld the ends of the rectangular tubing to the side curb angle (see "Figure 26: Welding the 4 X 3 Rectangular Tubing to the Curb Angles" on page 25. Add vertical welds

at the ends of the tube between tube surface and side curb angle surface.

4. Note the centerline positions of the tilt bar pockets on the dock leveler.

5. Transfer the centerline positions to the rectangular tube.

6. Weld 1 inch butt weld at the mark off locations on the rectangular tube

7. Based on the dock leveler's rated capacity, see "WELDING REFERENCE INFORMATION" on page 28 to determine the length of the weld for dimension "A"

8. Refer to the rest of the installation section of the owner's manual to install the dock leveler.

9. Confirm that all steps of the installation instructions have been completed. Fill out the following information.

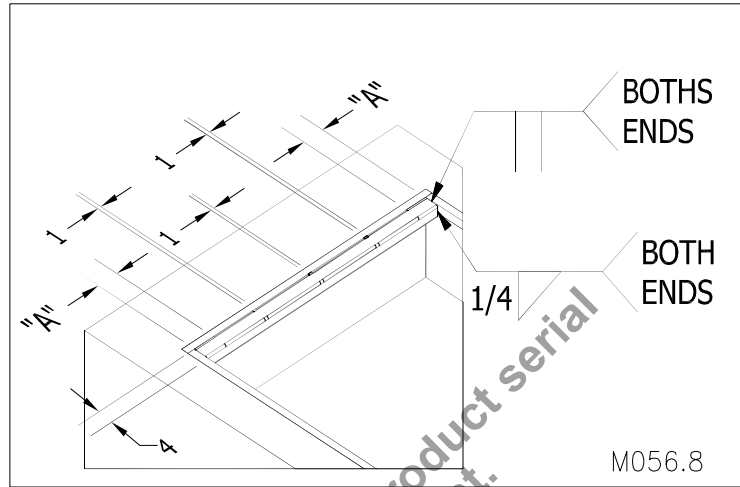

Figure 26: Welding the 4 X 3 Rectangular Tubing to the Curb Angles

Installer Name (Print)

Installer Signature

Date Installation Completed

FILLER PLATE INSTALLATION INSTRUCTIONS (WITH TWO TUBES & TWO SUPPORT BARS)

1. Before installing the filler plate and dock leveler, read the "INSTALLATION INSTRUCTIONS" section of the owner's manual on page 8.
2. Locate the two support bars on one of the rectangular tubes. The support bar should be positioned halfway between the center span of the tube to the end of the tube.
3. Weld the support bars in place using full fillet welds.
4. Slip the levelling tubes over the support bars and lightly tack in place so that it does not fall off while inverting the rectangular tube as indicated in "Figure 27: Welding the 4 X 3 Rectangular Tubing to the Curb Angles" on page 26.

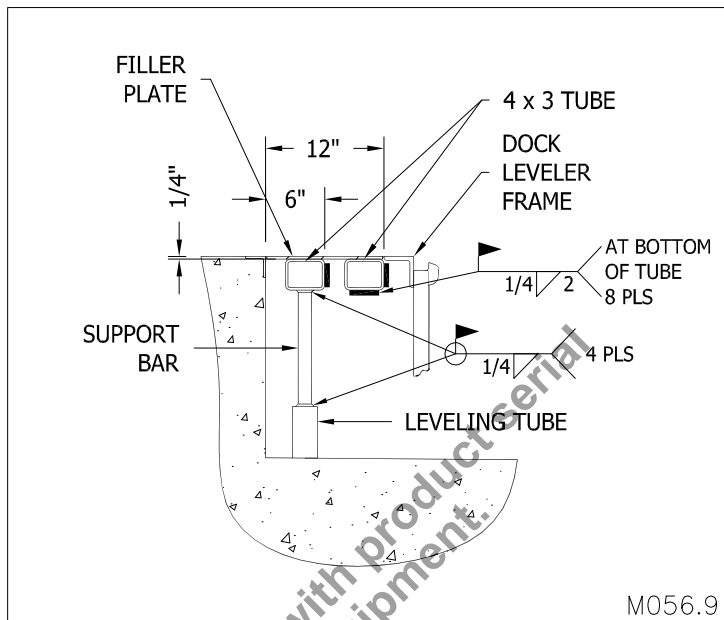

Figure 27: Welding the 4 X 3 Rectangular Tubing to the Curb Angles

5. Position the 4 X 3 inch rectangular tubes as indicated in "Figure 27: Welding the 4 X 3 Rectangular Tubing to the Curb Angles" on page 26. Make sure the top surface of the rectangular tube is 1/4" below the top surface of the curb angle. This will allow the filler plate to be welded flush to the top surface of the curb angle.
6. Weld the ends of the rectangular tubing to the side curb angle as indicated in "Figure 27: Welding the 4 X 3 Rectangular Tubing to the Curb Angles" on page 26. Add vertical welds at the ends of the tube between tube surface and side curb angle surface.
7. Remove the tack weld from step 4 and allow the levelling tubes to settle to the pit floor.

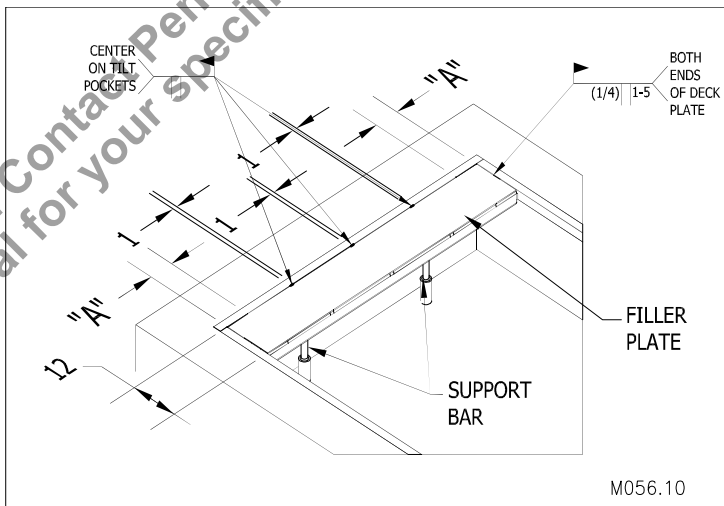

Figure 28: Installing the filler plate

8. Weld the levelling tubes to the support bars using full fillet welds as indicated in "Figure 27: Welding the 4 X 3 Rectangular Tubing to the Curb Angles" on page 26.
9. Note the centerline positions of the tilt bar pockets on the dock leveler.
10. Transfer the centerline positions to the back side of the filler plate that will adjoin the rear curb angle.
11. Place the filler plate on top of the rectangular tubes as indicated in "Figure 28: Installing the filler plate" on page 26 making sure the filler plate sits flat and square to the rear and side curb angles.
12. Weld 1 inch butt weld at the mark off locations on the deck plate as indicated in "Figure 28: Installing the filler plate" on page 26.

13. ___ Based on the dock leveler's rated capacity, see "WELDING REFERENCE INFORMATION" on page 28 to determine the length of the weld for dimension "A".
14. ___ Refer to the rest of the installation section of the owner's manual to install the dock leveler.
15. ___ Confirm that all steps of the installation instructions have been completed. Fill out the following information.

Installer Name (Print)

Installer Signature

Date Installation Completed

FILLER PLATE INSTALLATION INSTRUCTIONS (WITH TWO TUBES & FOUR SUPPORT BARS)

1. ___ Before installing the filler plate and dock leveler, read the "INSTALLATION INSTRUCTIONS" section of the owner's manual on page 8.
2. ___ Locate the two support bars on the rectangular tubes (two support bars per rectangular tube). The support bar should be positioned halfway between the center span of the tube to the end of the tube.
3. ___ Weld the support bars in place using full fillet welds.
4. ___ Slip the levelling tubes over the support bars and lightly tack in place so that it does not fall off while inverting the rectangular tube as indicated in "Figure 29: Welding the 4 X 3 Rectangular Tubing to the Curb Angles" on page 27.
5. ___ Position the 4 X 3 inch rectangular tubes as indicated in "Figure 29: Welding the 4 X 3 Rectangular Tubing to the Curb Angles" on page 27. Make sure the top surface of the rectangular tube is $\frac{1}{4}$ " below the top surface of the curb angle. This will allow the filler plate to be welded flush to the top surface of the curb angle.
6. ___ Weld the ends of the rectangular tubing to the side curb angle as indicated in "Figure 29: Welding the 4 X 3 Rectangular Tubing to the Curb Angles" on page 27. Add vertical welds at the ends of the tube between tube surface and side curb angle surface.
7. ___ Remove the tack weld from step 4 and allow the levelling tubes to settle to the pit floor.
8. ___ Weld the levelling tubes to the support bars using full fillet welds as indicated in "Figure 29: Welding the 4 X 3 Rectangular Tubing to the Curb Angles" on page 27.
9. ___ Note the centerline positions of the tilt bar pockets on the dock leveler.
10. ___ Transfer the centerline positions to the back side of the filler plate that will adjoin the rear curb angle.

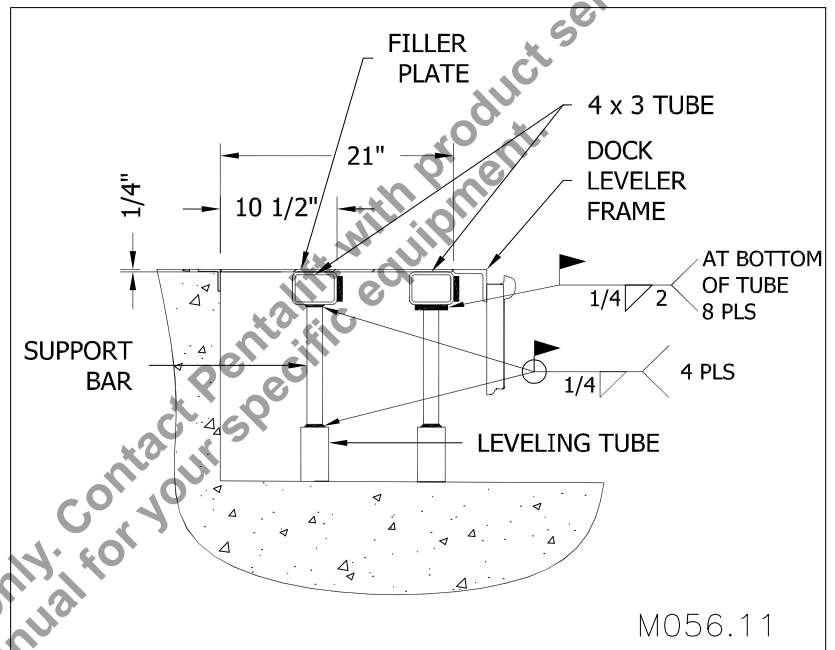

Figure 29: Welding the 4 X 3 Rectangular Tubing to the Curb Angles

11. ___ Place the filler plate on top of the rectangular tubes as indicated in "Figure 30: Installing the filler plate" on page 28 making sure the filler plate sits flat and square to the rear and side curb angles.
12. ___ Weld 1 inch butt weld at the mark off locations on the deck plate as indicated in "Figure 30: Installing the filler plate" on page 28.
13. ___ Based on the dock leveler's rated capacity, see "WELDING REFERENCE INFORMATION" on page 28 to determine the length of the weld for dimension "A".
14. ___ Refer to the rest of the installation section of the owner's manual to install the dock leveler.

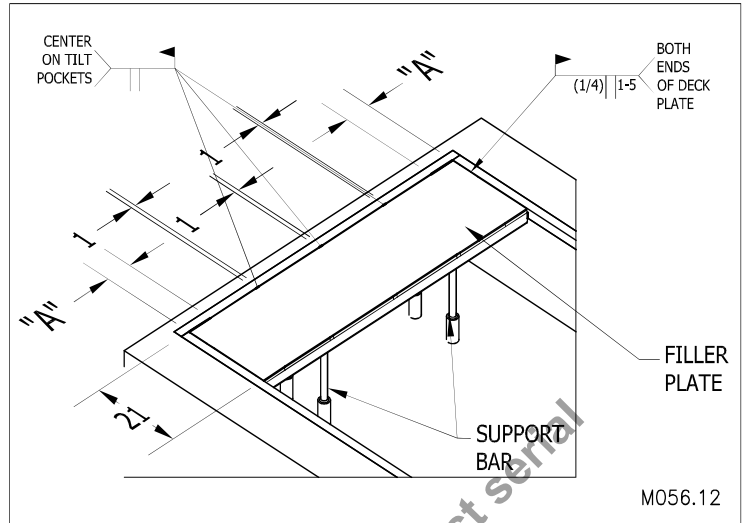

Figure 30: Installing the filler plate

15. ___ Confirm that all steps of the installation instructions have been completed. Fill out the following information.

Installer Name (Print)

Installer Signature

Date Installation Completed

WELDING REFERENCE INFORMATION

- Observe and obey all welding safety requirements per AWS D1.1-92. (W117.2-74 in Canada.)
- Welding electrodes are to be clean and free from moisture.
- Material to be welded must be clean and free of oils, excessive millscale/rust etc.
- All craters are to be filled to a minimum of 85% of the cross sectional area of the weld.
- All under cutting is to be removed by either welding, grinding or a combination of both.
- Maximum reinforcement on butt welds is 1/8".
- Use highest current possible per chart below to obtain satisfactory weld.

<i>Electrode</i>	E7018	
<i>Diameter</i>	1/8"	5/32"
<i>Amperage</i>	130-150	140-180

<i>Rated Capacity</i>	"A" Dimension, (Figure 13: Back Angle Weld of Dock Leveler on page 16)
25,000 lb 30,000 lb HC 30,000 lb HD 35,000 lb 40,000 lb	3"
45,000 lb 50,000 lb	6"

ELECTRICAL REFERENCE CHART

Ensure that the thermal overload relay is set to match the full load current as shown on the motor name plate. Consult all applicable electrical codes.

ELECTRICAL REFERENCE					
Length of branch circuit which will have a 2% voltage drop at full load current (copper wire) ft/m. NOTE: Calculations are based on 30 C Ambient	AWG	115/1/60			
	12	38.1ft/ 11.6m			
	10	60.6 ft/ 18.5m			
	8	96.4 ft/ 29.4m	The values given are intended to be a rough wiring guide only. Be sure to check all applicable electrical codes before wiring.		
	6	153.2 ft/ 46.7m			
Approximate Motor Current (full load) TENV Unit		12 Amps			

Note On Capacity: The dock leveler capacity indicated on the serial plate must be divided with a factor to accommodate dynamic loading factors. For more information see Pentalift document - Dock Leveler Capacity – Understanding Loading Dock Capacity at <http://www.pentalift.com/dock-leveler-capacity.php>



FAILURE TO PROPERLY INSTALL ANY PENTALIFT DOCK LEVELER MAY RESULT IN PROPERTY DAMAGE, BODILY INJURY OR DEATH AND WILL VOID ALL WARRANTIES.

INSTALLATION PICTURES (PIT INSTALLATION)

Upon completion of installation, photograph the following views as depicted below. Keep photos with owners manual.

1. ___ Front angle shims. (See "Figure 31: Front Angle & Deck Stop Shims" on page 30)
2. ___ Deck stop shims. (See "Figure 31: Front Angle & Deck Stop Shims" on page 30)

NOTE: Deck stops for standard dock levelers are located on the front angle.

3. ___ Rear shims (Left and Right side). (See "Figure 33: Rear Shims" on page 30)
4. ___ Rear angle of dock leveler in parked position showing flush and level to the floor/curb angle. (See "Figure 34: Rear Angle Flush with Curb Angle" on page 30)

Installer Name (Print)

Installer Signature

Date Installation Completed

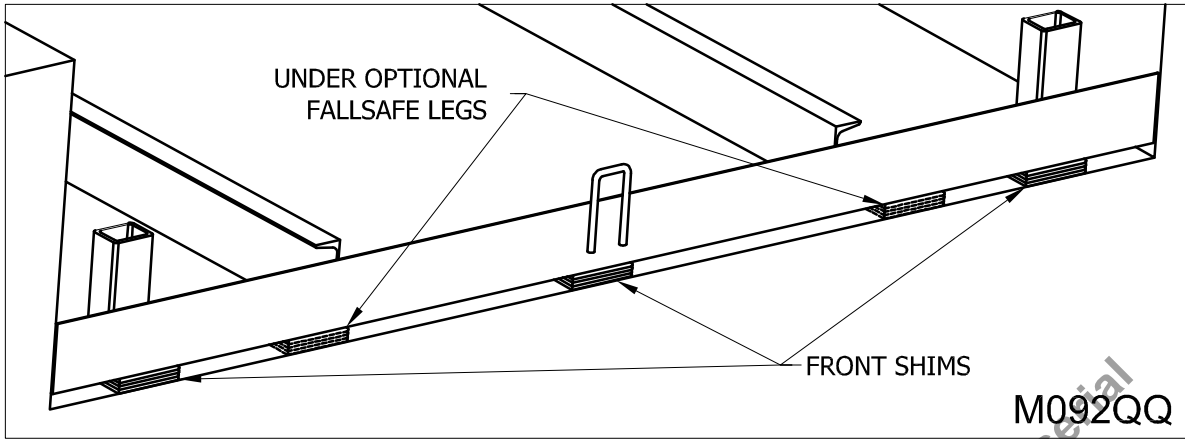

Figure 31: Front Angle & Deck Stop Shims

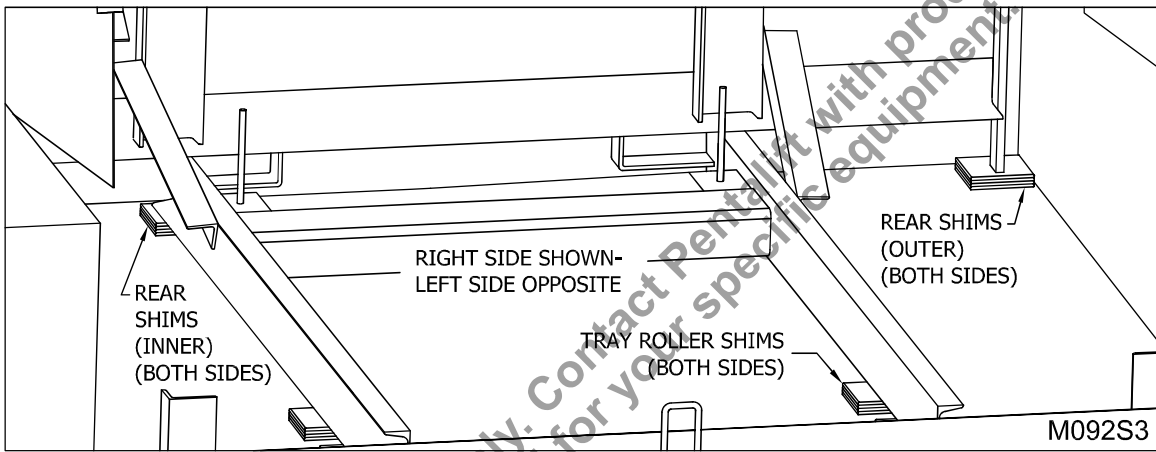

Figure 33: Rear Shims

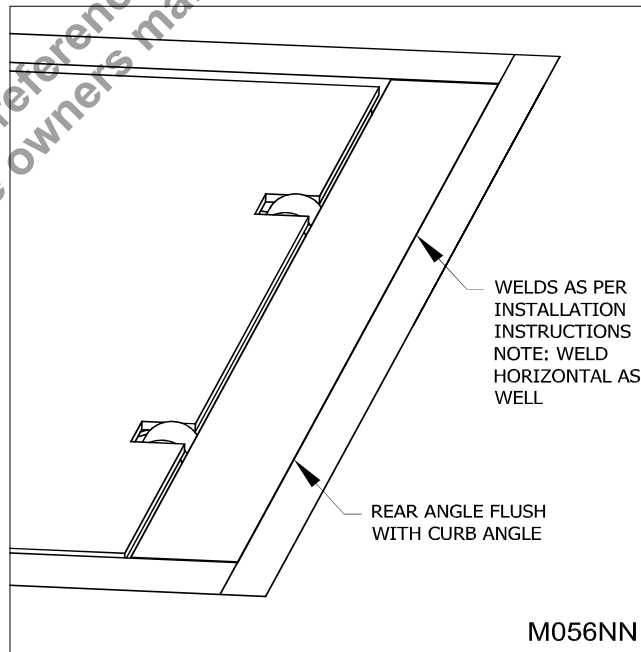

Figure 34: Rear Angle Flush with Curb Angle

INSTALLATION INSTRUCTIONS

POUR-IN DOCK LEVELERS



Do not install, operate or service this product unless you have read and fully understand the entire contents of this manual. Failure to do so may result in property damage, bodily injury or death.

NOTE: A very high level of field issues with this type of equipment can be directly attributed to improper or incomplete installation. The installation instructions and information provided for this equipment is thorough. A step by step sequence for installation is provided. All steps must be followed and completed to provide a complete installation. Incomplete or improper installations can lead to equipment malfunction and / or damage, create safety issues and void warranties. Please follow all installation and set ups steps as indicated in the installation instructions and owner's manual. If you are unclear or uncertain regarding any of the steps contact your Pentalift representative for clarification. A copy of the completed steps listing with the sign off and photos of the installation as indicated at the conclusion of the installation instructions will be required prior to any Pentalift factory trouble shooting assistance.

IMPORTANT

PREPARATION PRIOR TO INSTALLATION

NOTE: Prior to accepting shipment and pouring, check pour-in pan and structural angle for damage. Perform installation instructions in the same sequence as they are listed below. To accommodate a complete installation there is a blank space provided beside each numbered step in the installation instructions. Please check off the steps sequentially as they are completed. This will assist in confirming a complete installation.

IMPORTANT: In some instances shipping and handling can result in damage to the dock leveler. Prior to accepting the shipment and prior to installing the equipment check the dock leveler for damage. Be sure to check the pour-in pan components and the pour in angles (See "Figure 37: Pour-In Pan Components" on page 33). If damage does exist;

- 1) Do not accept the shipment until you have made a damaged notation on the delivery receipt. It is the consignees obligation to count and examine the condition of the shipment at the time of the delivery.
 - 2) Do not install the equipment until appropriate repairs are made.
 - 3) Contact your Pentalift representative for assistance.
-



Before doing any installation, maintenance, inspection or trouble shooting, barricade all areas from traffic around the work area inside (and outside if applicable) for safety and post appropriate warning signs.

⚠ DANGER

Before doing any electrical work, be certain that the power is disconnected with a fused disconnect, properly tagged and locked out. Fused disconnect and lockout device (supplied and installed by others) must meet with all applicable codes and regulations. All electrical work must be performed by a qualified electrician in accordance with all applicable codes and regulations.

⚠ DANGER

MAKE SURE LIFTING AND SLINGING DEVICES ARE OF SUFFICIENT CAPACITY, USED IN THE CORRECT MANNER AND ARE IN GOOD WORKING ORDER. ALL LIFTING, POSITIONING AND INSTALLATION, AS WELL AS THE BREAK-IN AND PERFORMANCE CHECK MUST BE DONE BY QUALIFIED PERSONNEL TRAINED AND EXPERIENCED IN NECESSARY SAFETY PROCEDURES.

⚠ DANGER

NEVER GO BENEATH THE DOCK LEVELER FOR ANY REASON UNLESS THE DECK AND LIP ARE PROPERLY SUPPORTED (SEE "HOW TO SUPPORT..." IN THE OWNER'S MANUAL) AND THE POWER IS DISCONNECTED, PROPERLY TAGGED AND LOCKED OUT. IT IS THE RESPONSIBILITY OF THE OWNER TO ENSURE THAT NO LOAD NOR TRAFFIC IS PLACED ON THE DECK WHILE THE MAINTENANCE STAND IS ENGAGED. THE CONSTRUCTION OF THE MAINTENANCE STAND IS INTENDED TO SUPPORT THE WEIGHT OF THE UNLOADED DOCK LEVELER ONLY.

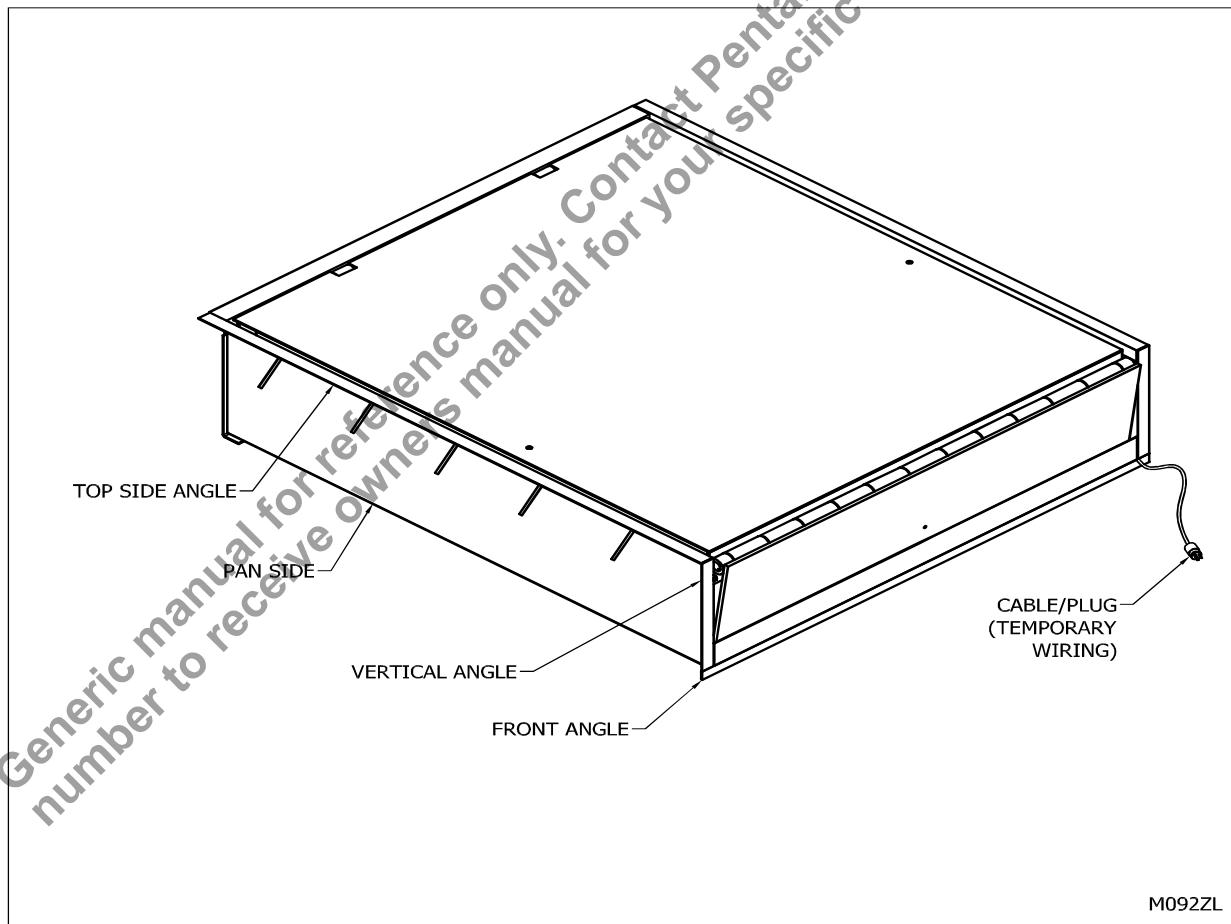

Figure 37: Pour-In Pan Components

1. ___ Provide holes in the side pan of the dock leveler for the electrical and/or hydraulic conduits. (See “Figure 44: Conduits Required” on page 37)

NOTE: It is vital that the required connections be made through the side panel of the pour-in frame. This must be done prior to the pouring of concrete around the conduit location zone. Conduit requirements are determined from the appropriate pour-in leveler arrangement drawing, the appropriate electrical schematic for the individual dock leveler order, as well as the electrical and mechanical codes that apply to the individual installation. Conduits must be routed through the lower rear section of the pour-in panel. The conduit installation zone is indicated in “Figure 45: Conduit Installation Zone” on page 37.

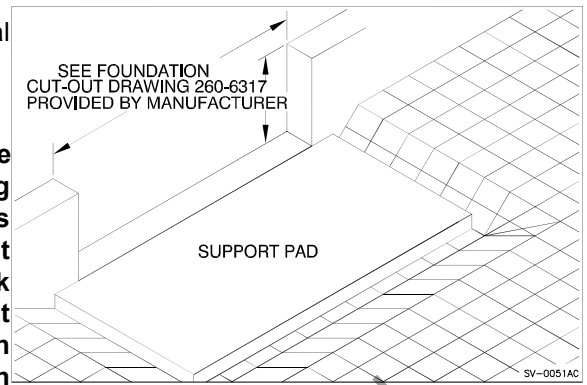

Figure 38: Foundation cut out and support pad

2. ___ Find the pre-determined floor level (See “Figure 38: Foundation cut out and support pad” on page 34) and ensure the foundation cut-out and support pad are in place to properly locate and support the dock leveler is appropriate according to the sizes shown on the dock leveler drawing provided by the Pentalift. For the dimensions of the foundation cut-out refer to Pentalift drawing 260-6317.
3. ___ Position the dock leveler into the foundation cutout (see “Figure 42: Dock Leveler in Position” on page 35).
4. ___ Shim the front and rear of the dock to the desired, correct and level position. Confirm side to side positioning at the pre-determined floor level.
5. ___ Ensure there is a one inch (1”) gap between the deck and side pan curb angles. Confirm this on both sides of the dock leveler. Once the gaps are confirmed as correct, ensure the adjusting bolts are in contact with the side panels. See “Figure 43: One Inch (1”) Gap” on page 35. Use the adjusting bolts to increase the gap to 1” if required.
6. ___ Securely brace the dock leveler to prevent any movement or “floating” during the pouring of the concrete. Use lag bolts in the provided lagging brackets to assist in securing the dock leveler (see “Figure 42: Dock Leveler in Position” on page 35). Note that these brackets are intended to assist in bracing the dock leveler and that consideration and use of additional supporting means may be required. Prior to installing the lags confirm that if shims are utilized the lag bolt length is increased to accommodate for the shimming, allowing proper and sufficient lag penetration into the concrete.
7. ___ Prior to pouring the concrete, confirm that pour-in pan sides and top side angles are straight and undamaged, reconfirm that the pan structure will maintain a 1” gap between edge of the dock leveler deck and the finished pan side walls for the entire length of the deck.
8. ___ Prior to pouring the concrete, re-examine the front and rear of the unit to ensure the top of the unit has remained level and in the desire final position. Once the concrete has been poured around the dock leveler, repositioning the dock leveler is very difficult and expensive. See “Figure 44: Conduits Required” on page 37. Ensure the temporary wire on blower is easily accessible. See “Figure 47: Accessible Temporary Wire” on page 31.
9. ___ Pour concrete to finished floor level and flush with the curb angle on all three (3) sides in **two stages**.

NOTE: Care must be taken when placing concrete around pan of the dock leveler. Excessive concrete force on the pan components will cause distortion and or deflection of the pan assembly. It may also cause the dock leveler to move from the desired final position. This could create many serious issues including and not limited to; impeding the required movement of the dock leveler. Creating misalignment of the dock leveler with the trucks and trailers, and look bad visually. It is very important to not create excessive forces onto dock leveler pan components. Concrete tampers or compactors should be used carefully as these can create high forces.

First Stage – allow concrete to flow under entire base of pan and ten inches (10”) up the sides. The purpose of this pour is to have the concrete flow under dock leveler for proper below frame support and to further support and hold the dock leveler in the desired location during the second stage pour. Allow the concrete to cure to full strength.

Second Stage – fill to pre-determined floor level and flush with the curb angle on all three (3) sides.

10. Remove all excess concrete.
11. Once the concrete is cured, remove the side adjusting bolts. (see “Figure 43: One Inch (1”) Gap” on page 35).
12. Remove the top shipping bolts (if equipped) and front shipping bolts and lifting brackets. (See “Figure 46: Shipping Wire, Bolts, and Lifting Devices.” on page 39)
13. For any model of air powered dock leveler, review the position of the top edge of the dock leveler deck relative to the top of the curb angle (See “Figure 40: Deck Alignment” on page 36). If the deck is too low in relation to the installation requirements, shim the dock leveler using steel shim(s) on both sides as indicated in “Figure 41: Shimming 16” & 18” Lips” on page 36 and in “Figure 41A: Shimming 20” Lips” on page 36.

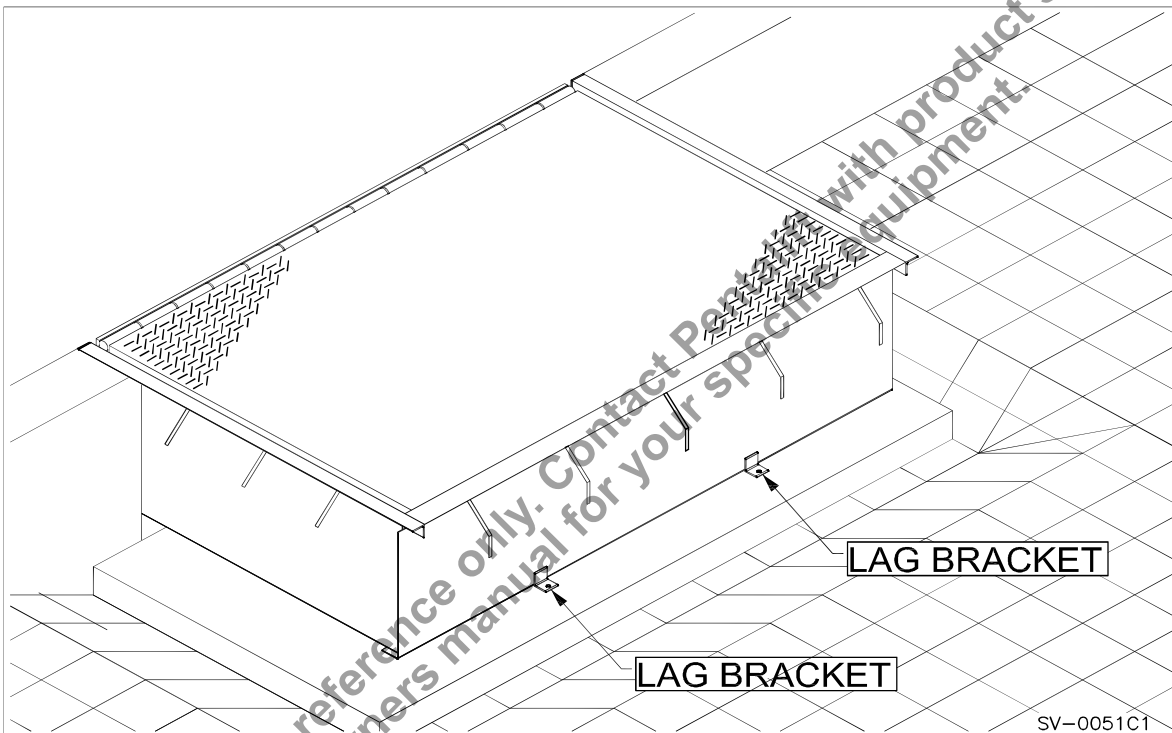

Figure 42: Dock Leveler in Position

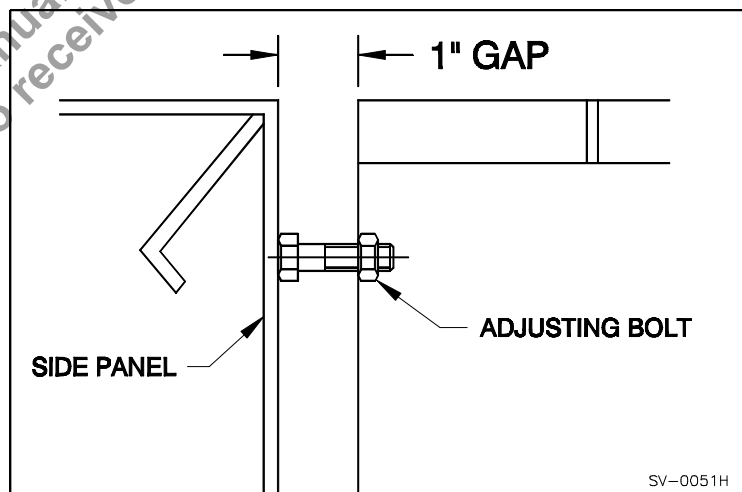

Figure 43: One Inch (1”) Gap

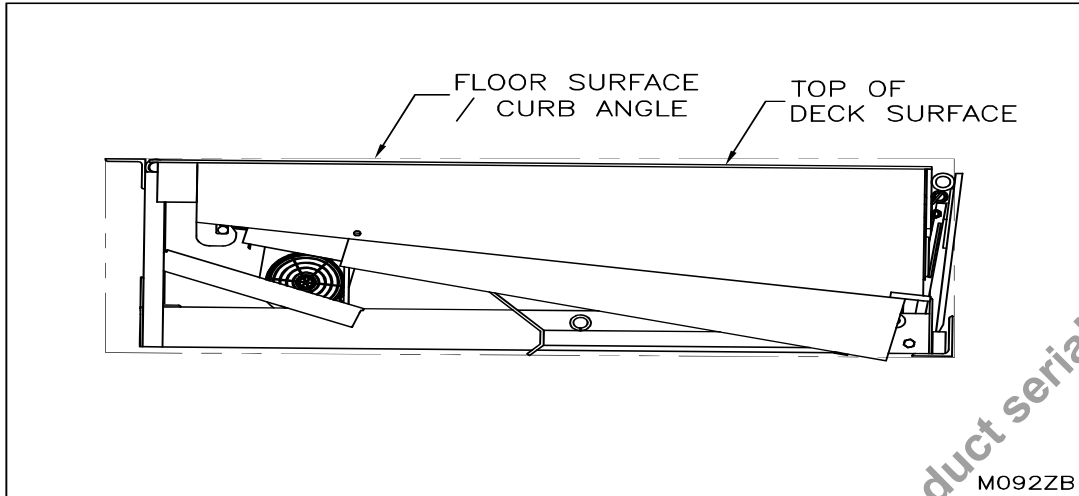

Figure 40: Deck Alignment

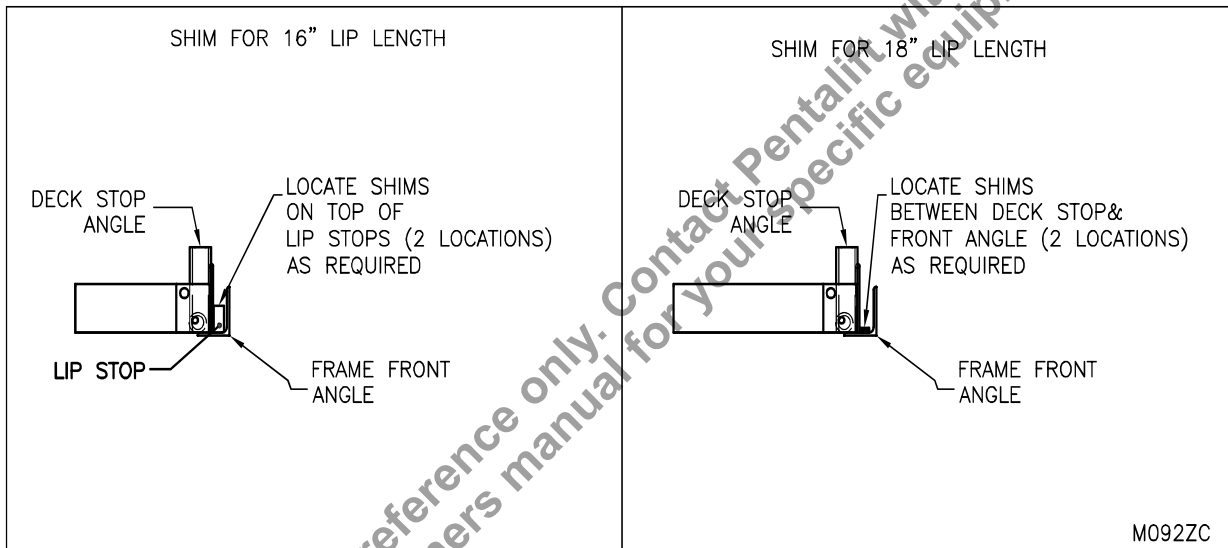

Figure 41: Shimming 16" & 18" Lips

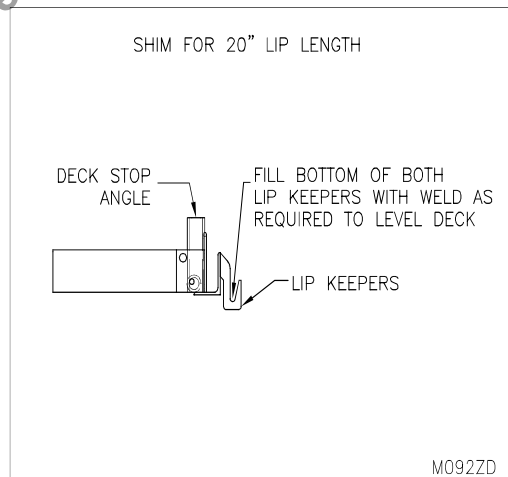

Figure 41A: Shimming 20" Lips

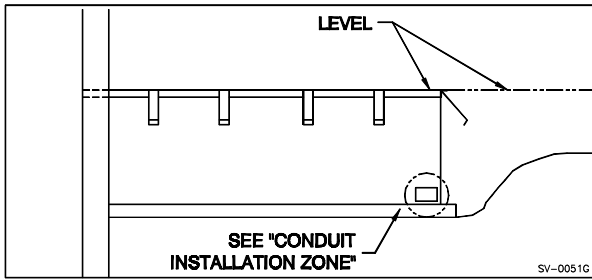

Figure 44: Conduits Required

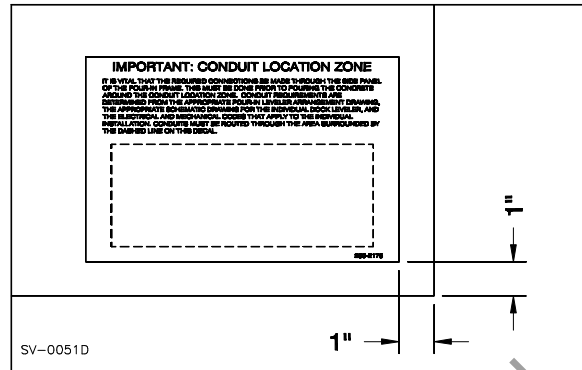

Figure 45: Conduit Installation Zone

Installer Name (Print)

Installer Signature

Date Installation Completed

AIR POWERED DOCK LEVELER:

1. Raise the dock leveler by connecting the temporary power cord and plug assembly supplied to a power supply (See "Figure 7a: Temporary Power Cord & Plug" on page 12)

⚠ DANGER

- WIRING MUST BE DONE BY A QUALIFIED ELECTRICIAN.
- ALWAYS USE APPROPRIATE LOCK-OUT PROCEDURES DURING ANY ELECTRICAL INSTALLATIONS.
- ASSURE SUPPLY VOLTAGE IS CORRECT.
- ON 3 PHASE UNITS ASSURE PHASE POLARITY IS CORRECT.
- ALWAYS OBSERVE ALL APPLICABLE ELECTRICAL CODES.

NOTE: The temporary wires supplied are intended to be used for lifting the deck for the initial installation only. Once the maintenance stand is in position, the temporary wires are to be removed from both the power supply and the dock leveler. Permanent wiring must be installed immediately.

NOTE: Do not push & hold the raise button after the leveler has fully raised and lip has extended, doing so may result in damage to the air bag and/or dock leveler.

⚠ DANGER

DO NOT DISCONNECT THE TEMPORARY POWER SUPPLY UNTIL MAINTENANCE STAND IS IN POSITION. DECK WILL AUTOMATICALLY LOWER WHEN POWER IS DISCONNECTED OR PUSH BUTTON IS RELEASED. ONCE MAINTENANCE STAND IS SECURELY IN PLACE, DISCONNECT TEMPORARY POWER SUPPLY.

STAY CLEAR OF THE EQUIPMENT'S OPERATING PATH AT ALL TIMES.

2. ___ Once the deck reaches its maximum height with the lip fully extended, support the dock leveler as instructed (see "SUPPORTING THE LEVELER FOR MAINTENANCE" on page 49).



The maintenance stand of this dock leveler is designed for use only when the dock leveler is securely welded into the dock leveler pit. Use of the stand is not recommended if the dock leveler is not securely welded into the pit (see "Figure 13: Back Angle Weld of Dock Leveler" on page 16). To support the dock leveler at times when installation welding is not in place, an appropriate generic maintenance stand that supports the dock leveler more centered on the dock leveler width is recommended.

3. ___ Support the lower half of the toe guard and remove the self tapping screw which holds it in the shipping position. Carefully lower the toe guard and avoid pinch points (see "Figure 46: Shipping Wire, Bolts, and Lifting Devices." on page 39)
 4. ___ Mount the control panel and the supplied instruction placard in an appropriate location (see "Figure 8: Control Panel & Placard Location" on page 14).
 5. ___ Locate a junction box with a standard 115/1/60 female receptacle (supplied by customer) on the vertical side of the pour-in pan with the top of box lower than the conduit hole and horizontally between the conduit hole and bottom of the pour-in pan (see "Figure 7b: Power Cord & Junction Box" on page 12 for relative position of junction box and conduit hole).
 6. ___ Use the provided power cord running from the blower assembly to connect the blower to the junction box. Route the power cord so that it does not come in the path of any of the moving parts of the dock leveler. Once the power cord is properly routed to the junction box, cut any access off and reinstall the supplied 115/1/60 plug that was provided on the cord. Discard the access material that was cut off.
 7. ___ Run the appropriate electrical wires from the control panel to the receptacle box through the conduit and the conduit hole at the side of pour-in pan.
 8. ___ Jumper wires must be added between terminal 3 and A2 of the contactor and between A1 of the contactor and terminal 4 of the push button of the control panel (see "Figure 65: Electrical Schematics- Basic Model (Jog Start)" on page 68).
 9. ___ Connect main power supply to the control panel.
- NOTE:** Blower requires full voltage at motor. Wire size should be heavy enough to prevent line voltage drop when motor is under load. (See "ELECTRICAL REFERENCE CHART" on page 41).
10. ___ Also screw down the jacking screws to remove any potential dead space between the concrete and underside of the pan. (See "Figure 48: Use Jacking Screw to Eliminate Dead Space" on page 39).
 11. ___ Confirm that all steps of the installation instructions have been completed. Fill out the following information.

Installer Name (Print)

Installer Signature

Date Installation Completed

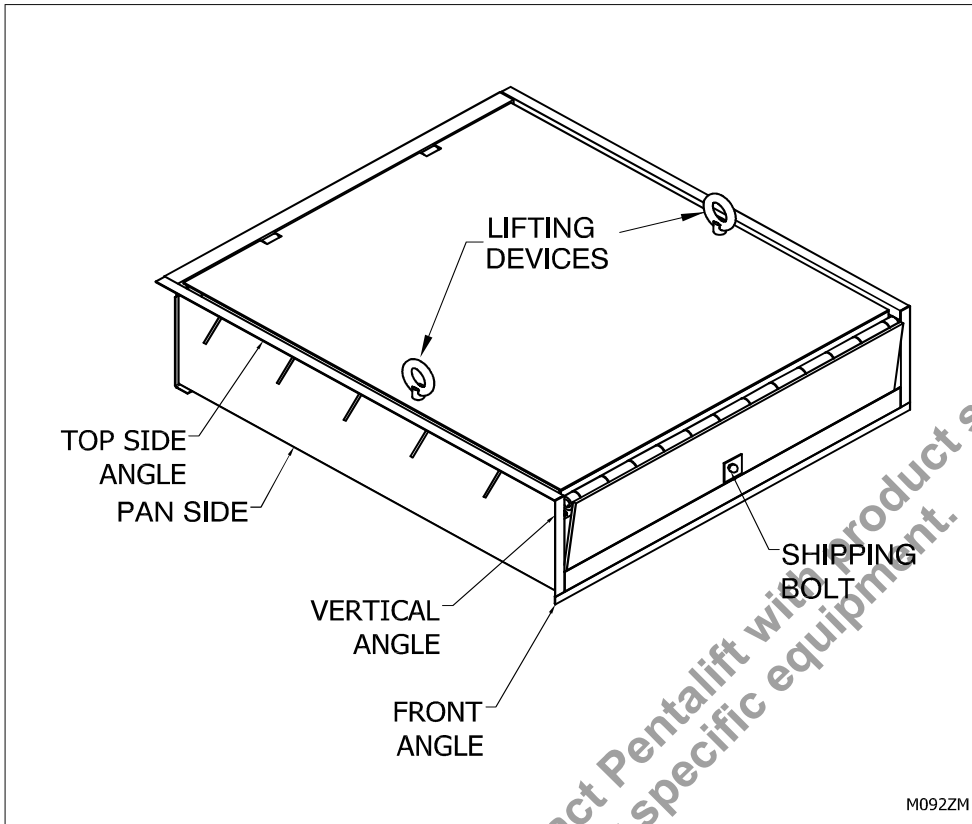

Figure 46: Shipping Wire, Bolts, and Lifting Devices.

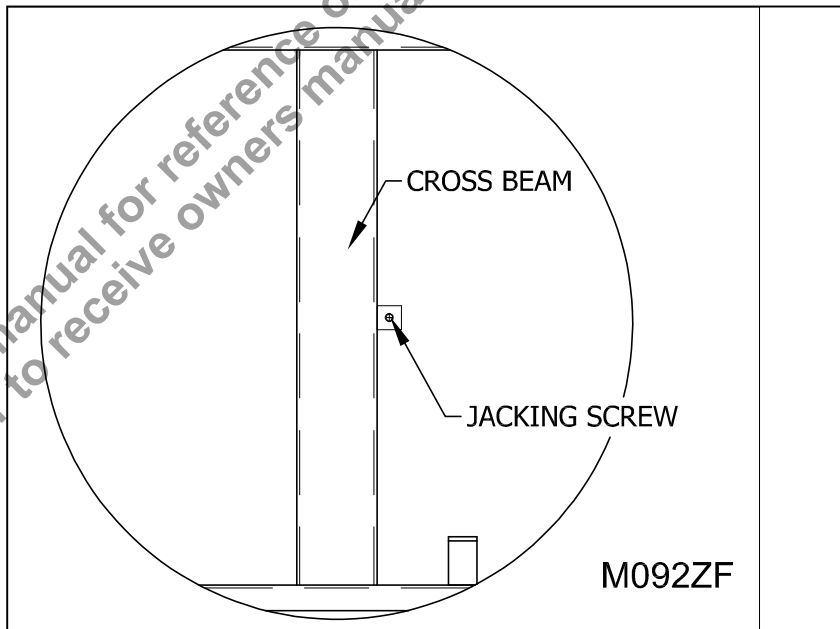

Figure 48: Use Jacking Screw to Eliminate Dead Space

INSTALLATION PICTURES (POUR-IN PAN)

Upon completion of installation, photograph the following views as depicted below. Keep photos with owners manual.

1. ___ Jacking screw(s). (See "Figure 51: Jacking Screw" on page 40)

Installer Name (Print)

Installer Signature

Date Installation Completed

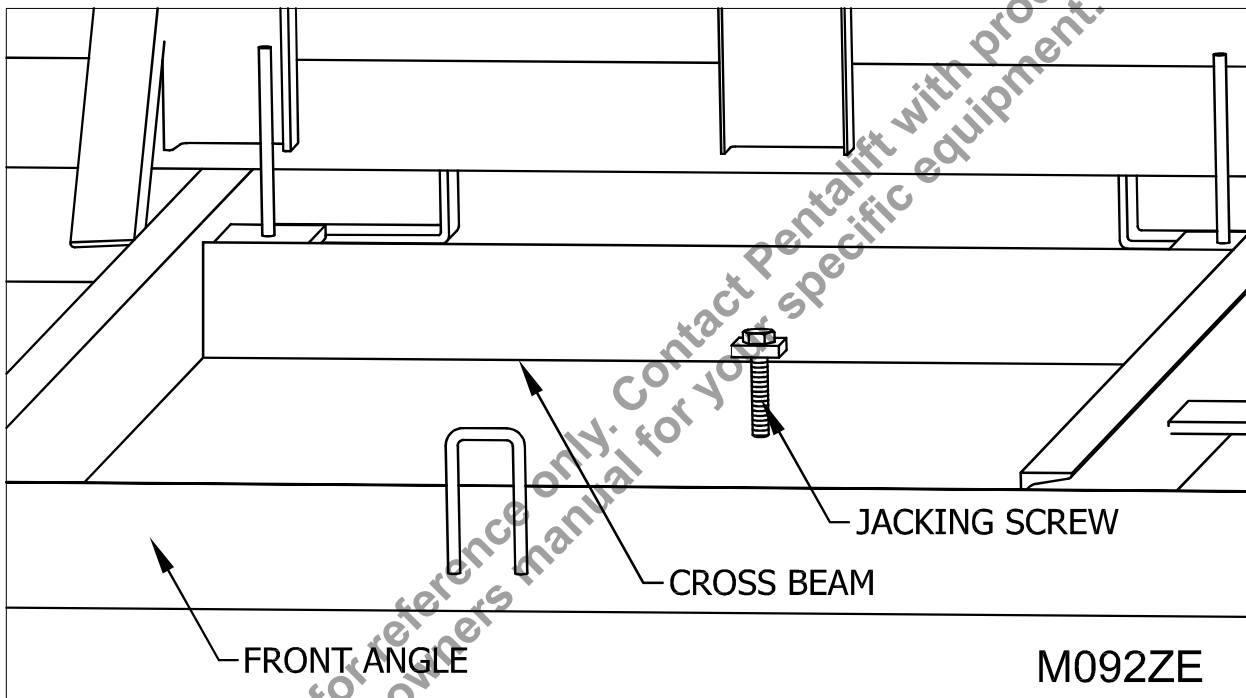

Figure 51: Jacking Screw

ELECTRICAL REFERENCE CHART

ELECTRICAL REFERENCE							
Length of branch circuit which will have a 2% voltage drop at full load current (copper wire) ft/m. NOTE: Calculations are based on 30 C Ambient	AWG	115/1/60					
	12	38.1ft/ 11.6m				The values given are intended to be a rough wiring guide only. Be sure to check all applicable electrical codes before wiring.	
	10	60.6 ft/ 18.5m					
	8	96.4 ft/ 29.4m					
	6	153.2 ft/ 46.7m					
Approximate Motor Current (full load) TENV Unit		12 Amps					



FAILURE TO PROPERLY INSTALL ANY PENTALIFT DOCK LEVELER MAY RESULT IN PROPERTY DAMAGE, BODILY INJURY OR DEATH AND WILL VOID ALL WARRANTIES.

Generic manual for reference only. Contact Pentlift with phone number to receive owners manual for your specific equipment.

Bumper Installation Guide lines

LOCATING DOCK BUMPERS DURING INSTALLATION:

1. For the majority of pit type dock leveler installations the dock bumpers are vertically positioned with the top edge of the bumper flush with the top of the loading dock wall face adjacent to top of the dock leveler pit vertical wall. (of the top of where the dock face meets the dock floor.)
2. For the majority of pit type dock leveler installations the dock bumpers are horizontally positioned with the inside edge of the bumper as close to the vertical edge of the dock leveler pit wall as reasonably possible.
3. Note: The word majority is utilized in the above two statements because there maybe exceptions to these rules. The purpose of the dock bumper is to create a designed impact area for approaching truck / trailer traffic. If the above location guidelines would result in locating the bumper such that it will not be properly impacted by the truck and trailers intended to be serviced at the facility, adjustments in positioning and the actual bumper arrangements may be required. Remember that trucks and trailers come in different physical configurations and sizing. The dock bumpers should be positioned to accommodate all the variations that will be serviced. Bumper risers are optionally added to accommodate lower dock heights and / or higher trucks. Bumper extensions or projected pits are optionally added to accommodate applications where the normal bumper projection is insufficient such as declined dock approaches. Contact your Pentalift representative for more information or guidelines to suit a specific application.

Installation methods I.E. Lagging and or welding:

1. Dock bumpers are generally attached in two ways; 1) utilization of concrete lag bolts or 2) welding in position. The use of these two methods depends on the type and configuration of the bumpers selected and the actual installation location.
2. It is quite common for the installation to be a combination of concrete lag bolts and welding.
3. When concrete lag bolts are utilized the dock bumper is usually provided with holes or has a bracket(s) on it with holes to accommodate the lagging. The dock bumper can be moved into the correct final position and used as a template to mark the required hole location for the lag bolts. Lag bolts that accommodate a minimum tensile value of 8710kN and shear value of 12015kN are to be utilized. Confirm the concrete arrangement and composition as well the that bumper hole location provides sufficient concrete material and strength to accommodate the selected lag bolts. Install the lag bolts according to the lag bolt manufacturer's instructions.
4. For welding attachment of bumpers, both the dock bumper and the loading dock area must be designed to accommodate. Typically the bumper will be provided with a flat bar (in place of the bracket with holes). That flat bar will line up with a steel surface that has been located and is suitably anchored into the dock face. Weld the dock bumper flat bar with ¼" welds and 2" stitches a maximum of 4" apart. More weld is better than not enough. Clean and paint the welds after application and cooling.

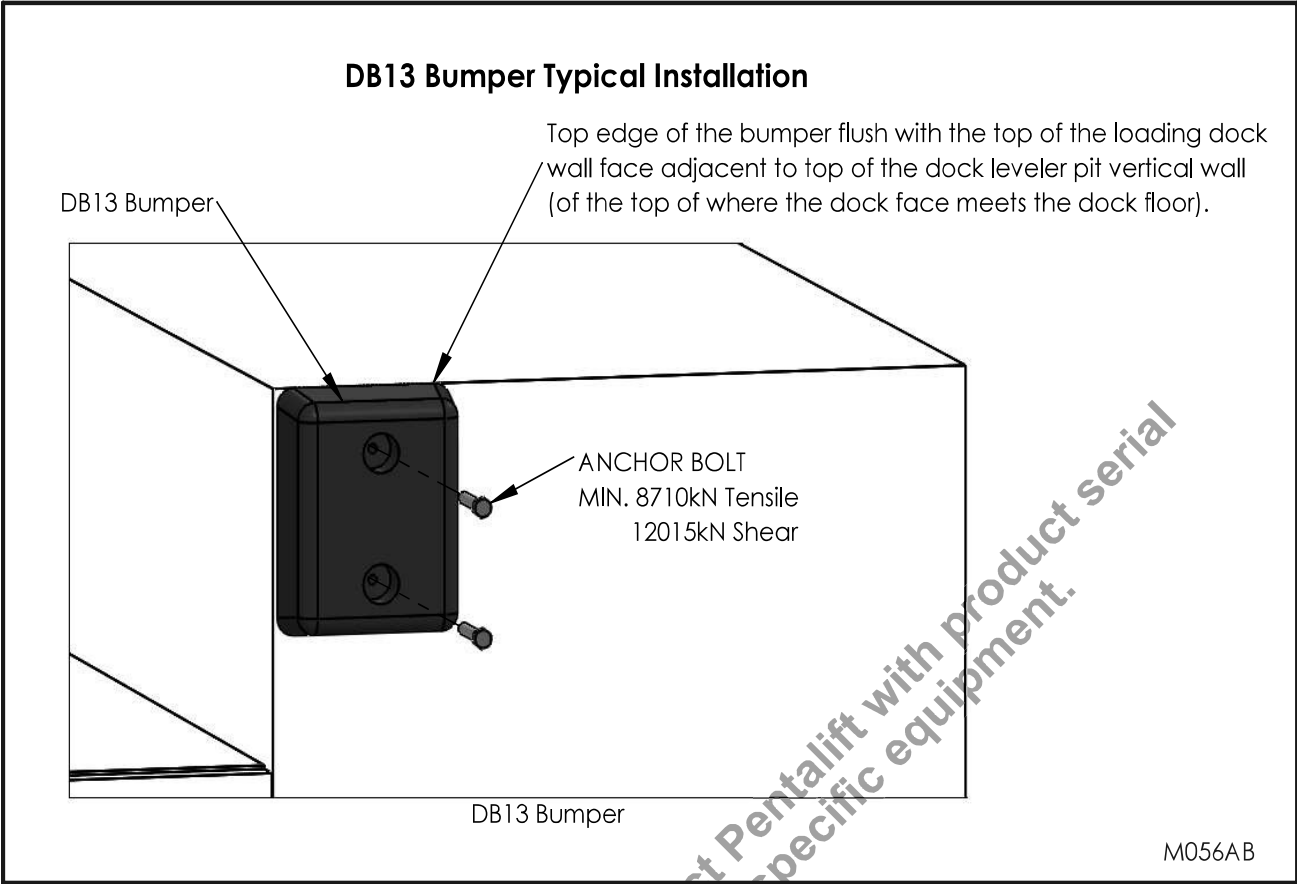

Figure 52: DB13 Installation

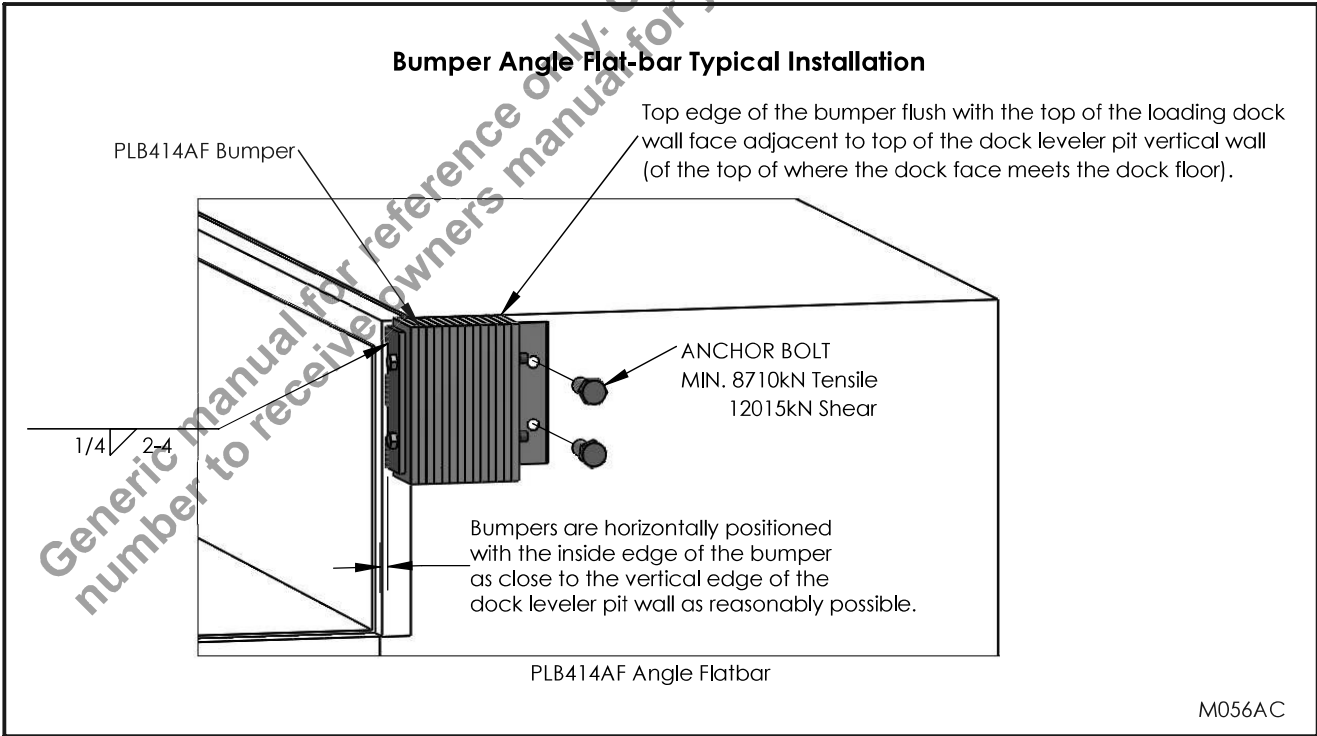

Figure 53: PLB414AF Installation

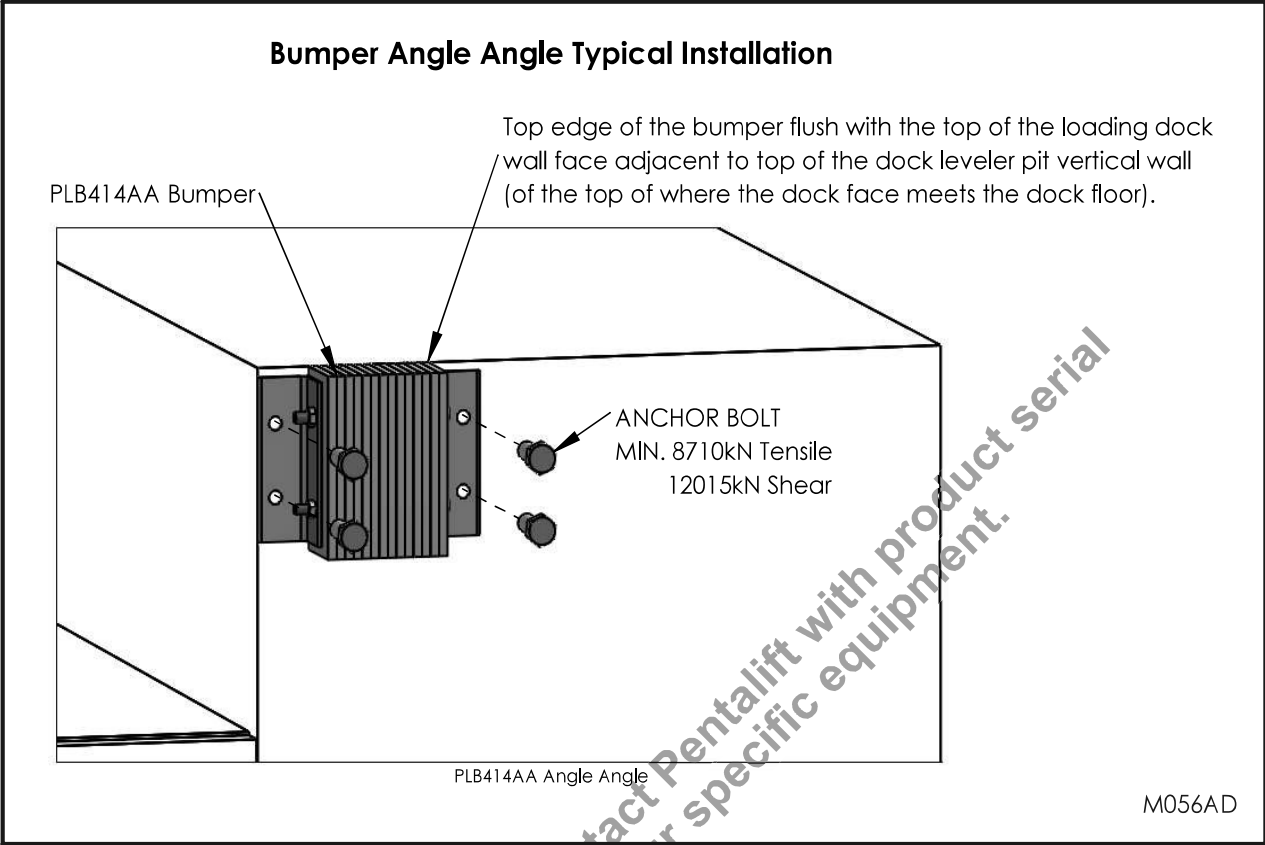

Figure 54: PLB414AA Installation

Generic manual for reference only. Contact Pentalift with product serial number to receive owners manual for your specific equipment.

BREAK-IN AND PERFORMANCE CHECK



BEFORE DOING ANY INSTALLATION, MAINTENANCE INSPECTION OR TROUBLE SHOOTING, BARRICADE ALL AREAS FROM TRAFFIC AROUND THE WORK AREA INSIDE (AND OUTSIDE IF APPLICABLE) FOR SAFETY AND POST APPROPRIATE WARNING SIGNS.

NOTE: IN SOME CASES THERE IS A CONSIDERABLE AMOUNT OF TIME BETWEEN THE SHIPMENT DATE AND USE OF YOUR DOCK LEVELER. THIS INITIAL BREAK-IN AND PERFORMANCE CHECK SHOULD BE PERFORMED BEFORE YOU BEGIN REGULAR USE OF YOUR DOCK LEVELER TO ENSURE THAT IT IS OPERATING PROPERLY.

NOTE: Read the SAFETY INFORMATION AND WARNINGS before operating the dock leveler. (See page iii)

NOTE: A very high level of field issues with this type of equipment can be directly attributed to improper or incomplete installation. The installation instructions and information provided for this equipment is thorough. A step by step sequence for installation is provided. All steps must be followed and completed to provide a complete installation. Incomplete or improper installations can lead to equipment malfunction and / or damage, create safety issues and void warranties. Please follow all installation and set ups steps as indicated in the installation instructions and owner's manual. If you are unclear or uncertain regarding any of the steps contact your Pentalift representative for clarification. A copy of the completed steps listing with the sign off and photos of the installation as indicated at the conclusion of the installation instructions will be required prior to any Pentalift factory trouble shooting assistance.

1. Ensure that any specified interlocks (e.g. overhead doors, restraints) are fully functional.



ALWAYS ASSURE NO ONE IS WITHIN 6 FEET OF THE FRONT (LIP END) OF THE DOCK LEVELER PRIOR TO ACTIVATION. STAY CLEAR OF DOCK LEVELER WHEN IT IS MOVING.

2. Operate the dock leveler several times as described in Operating Instructions.
3. Cycle the dock leveler through all its functions a minimum of ten times.

NOTE: As the truck will not be in place during this cycling, when dock leveler with the extended lips stops on the below stops or fallsafe legs, lift up on the front edge of the dock leveler lip. This will release the lip lock mechanism and allow the lip to lower into pendant as it would when it contacts the truck bed.

4. Raise leveler and install maintenance stand as outlined on page 49.
5. Inspect air bag for damage and leaks.
6. Lubricate all pivot points with Dexron III Automatic Transmission Fluid. (See "INSTALLATION, INSPECTION, MAINTENANCE AND LUBRICATION" on page 57)

7. **NOTICE** As the performance test is being conducted, watch closely for any signs that the dock leveler might not be operating properly. If you are in doubt, refer to "OPERATING INSTRUCTIONS" on page 46 and "TROUBLE SHOOTING GUIDE" on page 55 or contact your Pentalift representative.

OPERATING INSTRUCTIONS

Note On Capacity: The dock leveler capacity indicated on the serial plate must be divided with a factor to accommodate dynamic loading factors. For more information see Pentalift document - Dock Leveler Capacity – Understanding Loading Dock Capacity at <http://www.pentalift.com/dock-leveler-capacity.php>

NOTE: It is common for this product to be supplied in combination with other Pentalift Products. When the product supplied with other Pentalift products it is quite common for a combination control panel to be provided. The combination control panel will be a single control panel from which more than one product will be controlled and operated. If your installation incorporates the use of such a common control panel then read and follow all the instructions on the panel. If the instructions on the control panel conflict with instructions in this manual then follow the instructions on the control panel.

Note regarding above and above level ranges of dock levelers relative to dock leveler deck length :

This dock leveler is designed to accommodate truck and trailer beds that arrive at the facility with heights that are different than the dock height of the facility. The dock leveler deck assembly pivots and rests at angle to accommodate the variance in the truck or trailer bed height. In doing this dock leveler accommodates truck and trailer beds that are both above and below the loading dock floor height.

It is important to manage the extent of this compensation for the difference to a reasonable and desirable level. Factors that determine reasonable and desirable levels include but are not limited to the following:

- The length of the dock leveler deck assembly. The longer the dock leveler deck assembly is the better it will be for accommodating dimensional differences in the truck / trailer bed heights relative to the load dock height. For example, all other conditions being equal, an 8ft long dock leveler deck assembly accommodates a greater height differences than 6ft long dock leveler deck assembly. The longer deck assembly simply reduces the angle of incline that the loading / unloading equipment (IE fork lift or pump truck) have to drive up and down as they go in and out of the truck / trailer.
- The type of loading / unloading equipment being used at the loading dock. For example a gas powered fork lift truck will generally have more power and larger wheels to accommodate larger angles of incline than an electrically powered pallet truck or a manually pushed pallet truck or cart.
- For obvious reasons, larger inclines create more wear and tear on equipment that is powered driven and has brakes.
- Larger inclines can result impact loads applied to the dock leveler as the fork lift hits the inclined dock leveler assembly and this can overload the leveler and result in damage to the dock leveler.
- Large inclines can create safety concerns due to possible run away loads. This is particularly true for manually propelled pump trucks or carts. As well, large inclines can make it onerous to push the same equipment up the inclines.
- Consideration of these factors should be made at the time the loading dock is designed.
- These factors should also be considered whenever changes to the factors listed above change at the loading dock.

NOTE: Read the **SAFETY INFORMATION AND WARNINGS** before operating the dock leveler. (See page iii)



USE BY UNTRAINED PEOPLE CAN RESULT IN PROPERTY DAMAGE, BODILY INJURY OR DEATH. READ, KNOW, AND OBEY ALL OPERATING INSTRUCTIONS AND SAFETY INFORMATION. FOLLOW ALL OSHA REGULATIONS REGARDING THE USE OF THIS EQUIPMENT. DO NOT USE THE DOCK LEVELER IF ANY PART OF IT LOOKS BROKEN OR IF IT DOES NOT SEEM TO OPERATE PROPERLY. IF REPAIRS ARE NEEDED, CONTACT YOUR PENTALIFT REPRESENTATIVE.

⚠ DANGER

TO AVOID POSSIBLE PERSONNEL INJURY AS WELL AS, TO AVOID DAMAGE TO THE DOCK LEVELER AND /OR THE PRODUCT, DO NOT DRAG OR SLIDE ANYTHING ACROSS THE SURFACE OF THE DOCK LEVELER. ALWAYS ENSURE THE FORKLIFT FORKS ARE RAISED TO CLEAR THE DOCK LEVELER SURFACE AND THE DOCK LEVELER COMPONENTS.

NOTE: Always be certain that the truck/trailer is parked tight against the face of both dock bumpers and the truck wheels are chocked and/or that the truck is locked in place by a vehicle restraint (See “Figure 53: Minimum 4” Penetration” on page 47) before loading or unloading. All ‘air ride’ trailers must release the air from the suspension mechanism prior to activating the dock leveler for use.

DO NOT CONTINUE TO PUSH & HOLD THE RAISE BUTTON after the leveler has fully raised and lip has extended, doing so may result in damage to the air bag and / or dock leveler.

1. Load or unload End Loads with the deck and lip in the stored position as shown in “Figure 54: Deck in (Cross Traffic) Stored Position” on page 47(See “Figure 56: Below Level End Loads” on page 48)
2. Press and hold the **RAISE** button to raise the deck. The lip will automatically extend as the leveler deck is fully raised.
3. Release the **RAISE** button. The leveler will float down to the truck bed. If necessary release the optional fall safe legs to allow the dock leveler to float below level. **Note:** Restore the leveler to the dock level storage position for end loading (See “Figure 55: End Loading” on page 48)

⚠ WARNING

Never drive onto the leveler unless it is supported by either the truck bed, the below level stops or fall safe legs (if equipped). Doing so will increase the air bag pressure which may result in premature wear or damage to the leveler or air bag.

NOTE: If dock is equipped with “Fall Safe Legs” and they interfere with the dock levelers normal operation to float down onto the truck bed, remove the fall safe legs.

4. Proceed to load/unload the vehicle. When completed, return the dock to its stored position by depressing the RAISE button. As the leveler raises the lip will retract. When the lip is fully retracted and above the lip keepers or front angle of the frame, **release** the **RAISE** button. The leveler will float down to the stored position. Confirm lip is properly positioned behind lip keepers or tuck inside the frame front angle. (See “Figure 54: Deck in (Cross Traffic) Stored Position” on page 47)

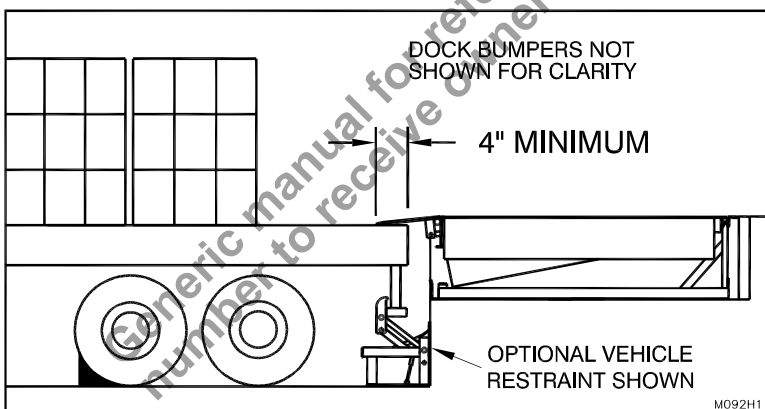

Figure 55: Minimum 4” Penetration

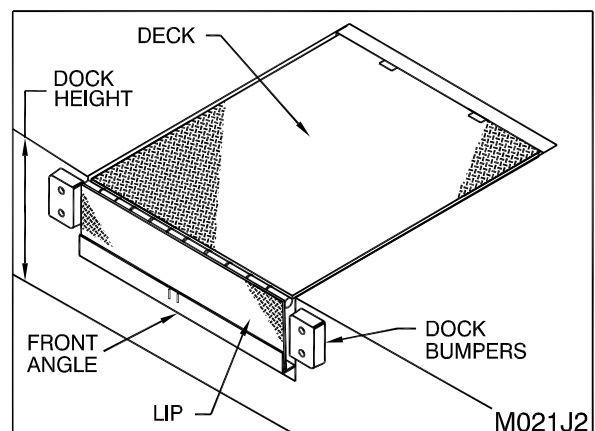

Figure 56: Deck in (Cross Traffic) Stored Position

END LOADING / UNLOADING

⚠️ DANGER

When the cargo at the rear of the truck does not allow the lip to fully extend and rest firmly on the truck bed as outlined under the operating instructions, then the end loading/unloading procedures must be used as outlined under the Operating Instructions. During end loading/unloading there will be a gap present between the dock leveler and the truck bed. Ensure that the front wheels of the fork truck never fall into the gap between the stored dock leveler and the truck. Immediately after the end loads are removed, the dock leveler is to be used with the lip extended as indicated under Operating Instructions.

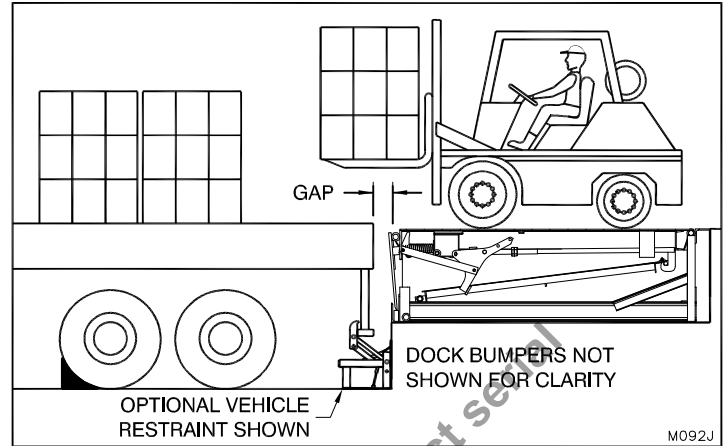

Figure 57: End Loading

END LOADING BELOW LEVEL CONTROL OPERATION

Below level end loading is required when the truck bed is below dock height and the cargo at the rear of the truck does not allow the lip to fully extend. In this instance, end loading/unloading cannot be completed with the leveler in its stored position. To position the leveler for end loading/unloading, follow the procedures outlined below.

1. Push and hold the RAISE button until the leveler is fully raised and the lip just starts to extend.

⚠️ CAUTION

ENSURE LIP DOES NOT OVER EXTEND AND DAMAGE FRAGILE CARGO.

2. Release the raise button and walk onto the dock leveler to pull the (optional) below level release ring (located at the front of the dock leveler) the lip will extend to clear the lip keepers as the dock leveler lowers to the below level stops (See "Figure 56: Below Level End Loads" on page 48).

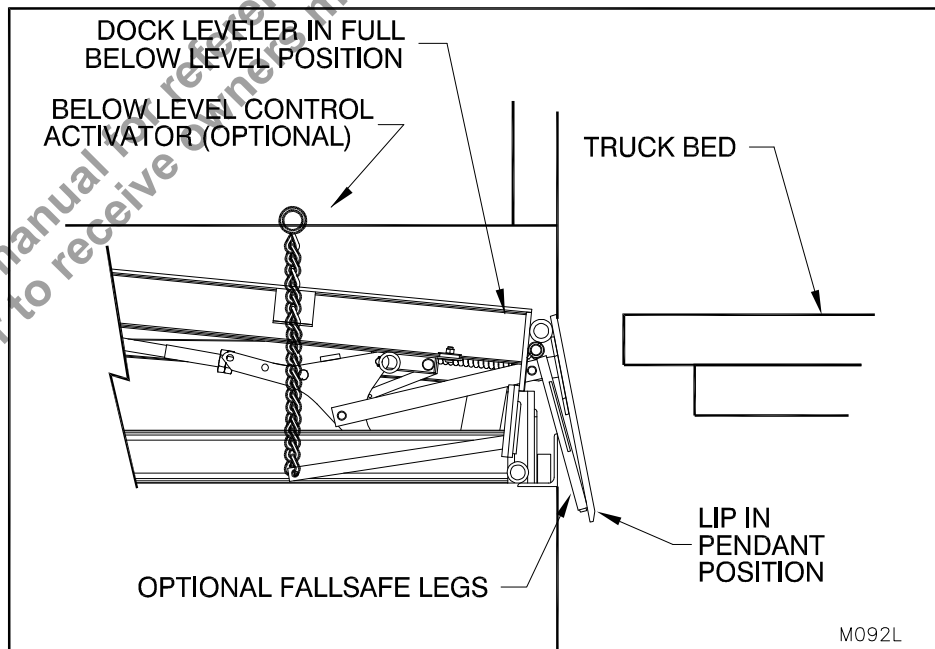

Figure 58: Below Level End Loads

SUPPORTING THE LEVELER FOR MAINTENANCE



Before doing any installation, maintenance, inspection or trouble shooting, barricade all areas from traffic around the work area inside (and outside if applicable) for safety and post appropriate warning signs.



NEVER GO BENEATH THE DOCK LEVELER FOR ANY REASON UNLESS THE DECK AND LIP ARE PROPERLY SUPPORTED AND THE POWER IS DISCONNECTED WITH A FUSED DISCONNECT, PROPERLY TAGGED AND LOCKED OUT. IT IS THE RESPONSIBILITY OF THE OWNER TO ENSURE THAT NO LOAD OR TRAFFIC IS PLACED ON THE DECK WHILE THE MAINTENANCE STAND IS ENGAGED. THE CONSTRUCTION OF THE MAINTENANCE STAND IS INTENDED TO SUPPORT THE WEIGHT OF THE UNLOADED DOCK LEVELER ONLY.



THE BLOCKING PROCEDURES DESCRIBED BELOW ARE SUITABLE ONLY FOR THE INSPECTION, TROUBLE SHOOTING AND MAINTENANCE PROCEDURES DESCRIBED IN THIS MANUAL. THEY MAY NOT BE SAFE FOR OTHER INSPECTION, MAINTENANCE AND REPAIR PROCEDURES THAT MAY BE REQUIRED. CONTACT YOUR AUTHORIZED PENTALIFT REPRESENTATIVE FOR DIRECTION PRIOR TO UNDERTAKING ANY ACTIONS OTHER THAN THOSE DESCRIBED IN THIS MANUAL. FAILURE TO PROPERLY ADHERE TO DECK BLOCKING PROCEDURES IS TO RISK THE SUDDEN AND UNCONTROLLED DESCENT OF THE DECK DURING MAINTENANCE OR INSPECTION. A FALLING DECK CAN CAUSE SEVERE INJURY OR DEATH. IF OTHER TYPE OF REPAIRS ARE REQUIRED, THEN A PENTALIFT AUXILIARY MAINTENANCE STAND IS TO BE UTILIZED. SEE PAGE *** FOR MORE INFORMATION ON HOW IT IS USED. THE AUXILIARY MAINTENANCE STAND IS AVAILABLE THROUGH THE PENTALIFT PARTS DEPARTMENT. IT IS PENTALIFT PART NUMBER 5000264



The maintenance stand of this dock leveler is designed for use only when the dock leveler is securely welded into the pit (see “Figure 13: Back Angle Weld of Dock Leveler” on page 16). To support the dock leveler at time when installation welding is not in place, utilize the auxiliary maintenance stand that supports the dock leveler more centered on the dock leveler width.

When performing any maintenance or trouble shooting of the dock leveler, always use the maintenance stand provided to support the dock leveler before attempting any routine maintenance or adjustments.

Raise the deck assembly to its maximum raised height and fully extend the lip. When facing the end of the Air Powered Dock Leveler, pull the maintenance stand from the stored position by pulling toward you until the maintenance stand is upright and the locking pin can be inserted, secure locking pin with padlock. Lower the deck assembly until both the deck and lip are supported by the maintenance stand as shown in the illustration below. If the deck and lip did not properly position, raise the deck assembly and reposition the maintenance stand so that the lip & deck are properly supported.

Also follow all safe working procedures and the Safety Instructions as stated in this manual.

See “Figure 59: Proper Placement of Maintenance Stand” on page 50 for the proper placement of the maintenance stand.

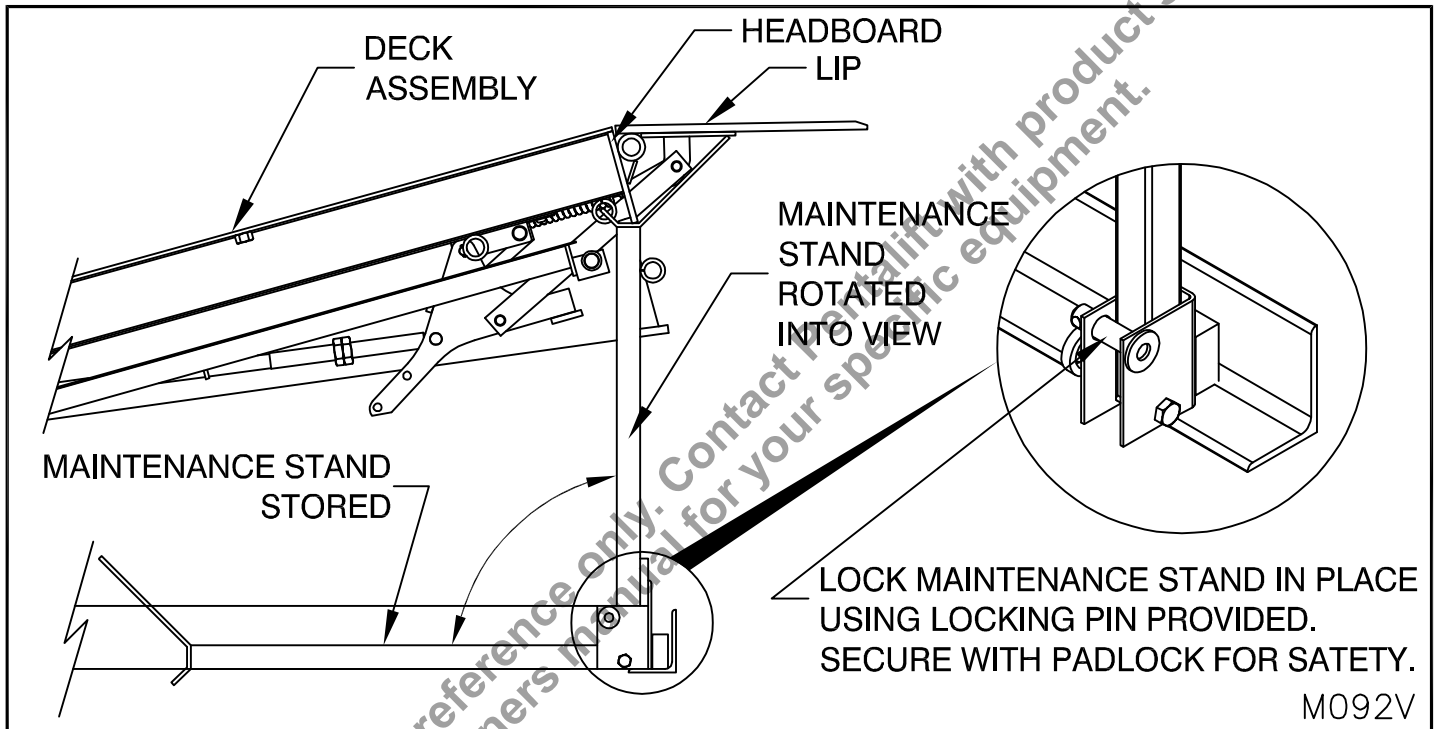

Figure 59: Proper Placement of Maintenance Stand

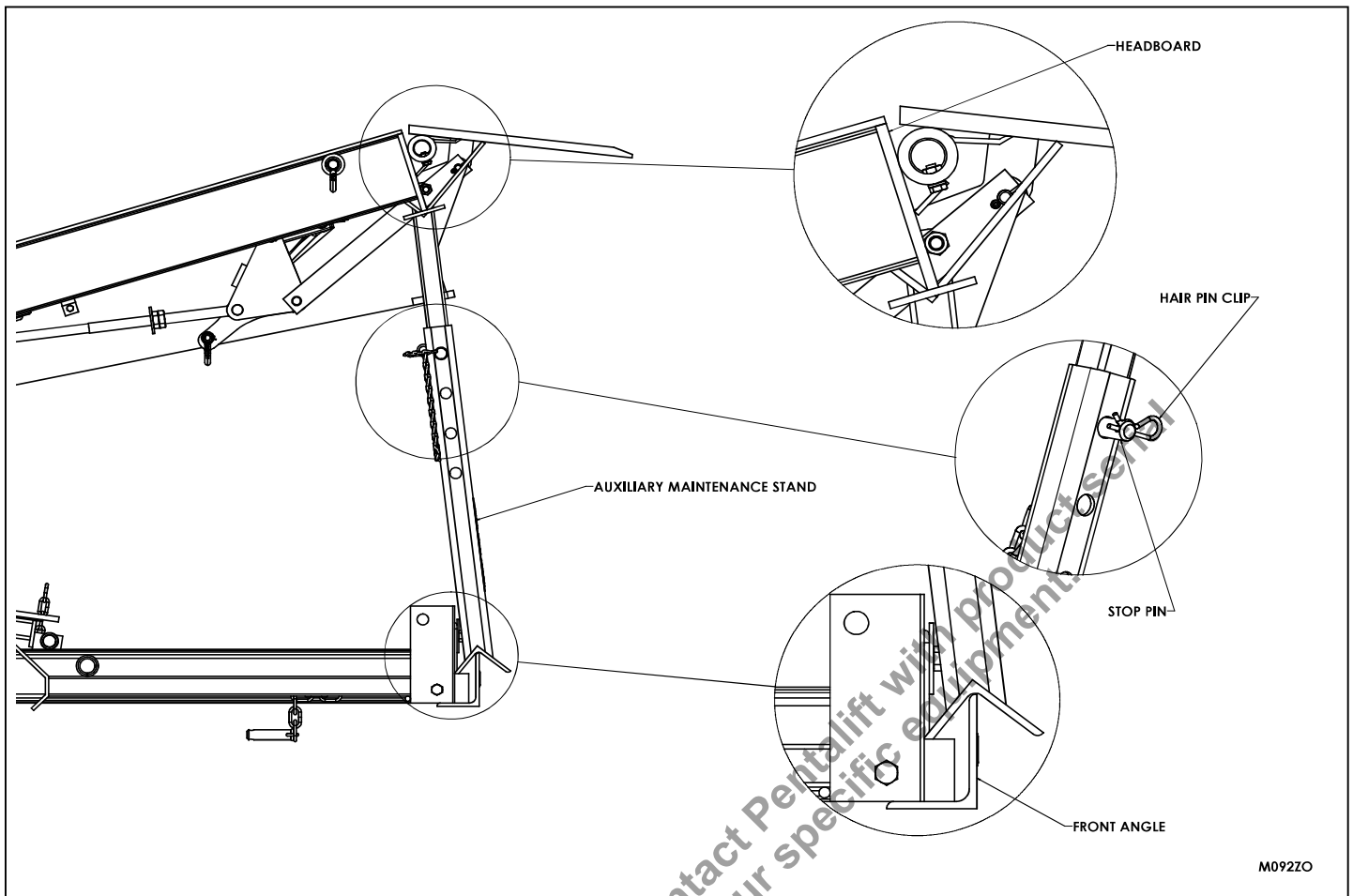

Figure 59.1: Supporting the Dock Leveler with the Auxiliary Maintenance Stand

Pentalift auxiliary maintenance stand

The auxiliary maintenance stand is available through the Pentalift part department. It is Pentalift part number 5000264. The Pentalift auxiliary maintenance stand is to be used whenever there are repairs or maintenance requirements of a more involved or substantial nature. Figure 59.1 on page 51 shows the stand. The stand is telescopic and facilitates its extension or retraction to match the required length for various models of dock leveler. The stand should be used by first engaging the integrated maintenance stand of the dock leveler as described in this manual. Then engage the auxiliary stand by locating the bottom end of the angle bracket on a substantial portion of the lower dock leveler fram. The upper angle bracket is then extended to capture a portion of the dock leveler headboard. The stop pin is utilized to lock the stand in one of the selectable extended positions. Retain the stop pin with the attached hair pin clip. Always make sure the maintenance stands are properly engaged prior to commencing repairs or going into the operating path of the dock leveler. If you are not confident regarding the proper application of the stands, do not commence work or go beneath the deck. Figure 59.1 on page 51 shows the proper use and location of the stand.

Note: In some instances, it may be best to utilize two auxiliary maintenance stands to support the dock leveler. The two maintenance stands can be spaced equally over the width of the dock leveler.



NEVER WALK ON THE LIP TO LOWER THE DOCK LEVELER.

Also follow all safe working procedures and the “SAFETY INFORMATION AND WARNINGS” on page II.

If the Air Powered Dock Leveler **IS EQUIPPED WITH** the **MECHANICAL FALLSAFE OPTION**, the following procedure must be used.

1. Raise the deck to its maximum raised height and fully extend the lip.
2. Facing the front of the Air Powered Dock Leveler locate the Maintenance Stand on left side, pull the Maintenance Stand from the stored position by pulling toward you until the maintenance stand is upright and the locking pin can be inserted and secured with a padlock. Lower the deck assembly until both the deck and lip are supported by the maintenance stand as shown in “Figure 59: Proper Placement of Maintenance Stand” on page 50. If the deck and lip did not properly position, push the raise button to raise the dock leveler and reposition the maintenance stand.

DISENGAGING THE MAINTENANCE STAND (ONCE ROUTINE MAINTENANCE HAS BEEN COMPLETED)

1. Ensure **NO TOOLS OR OTHER OBSTRUCTIONS** are in the pit area impeding the proper function and working space of the Air Powered Dock Leveler.
2. Remove the padlock securing the locking pin on the maintenance stand.
3. Press and hold the **RAISE** button until the lip extends and the deck assembly clears the maintenance stand.
4. Once the deck assembly has cleared the maintenance stand (allowing free movement) hold the **RAISE** button and remove the locking pin from the base of the maintenance stand. Lower the maintenance stand to its stored position.
5. Once Maintenance Stand is secured, release the **RAISE** button allowing the Air Powered Dock Leveler to deflate to its retracted position.
6. Placing both **GLOVED HANDS** on center of the lip push upward to disengage the locking mechanism (**CAUTION SUBSTANTIAL WEIGHT OF THE LIP WILL NOW BE SUPPORTED BY THE MAINTENANCE PERSON. ENSURE THERE IS NO POSSIBILITY OF BEING PINCHED OR TRAPPED BY THE LOWERING LIP**) lower lip to its standard vertical storage position.
7. Pressing the **RAISE** button, inflate the Air Powered Dock Leveler high enough so the lip may now return to its normal storing position. Air Powerd Dock Leveler is now ready for normal operation.

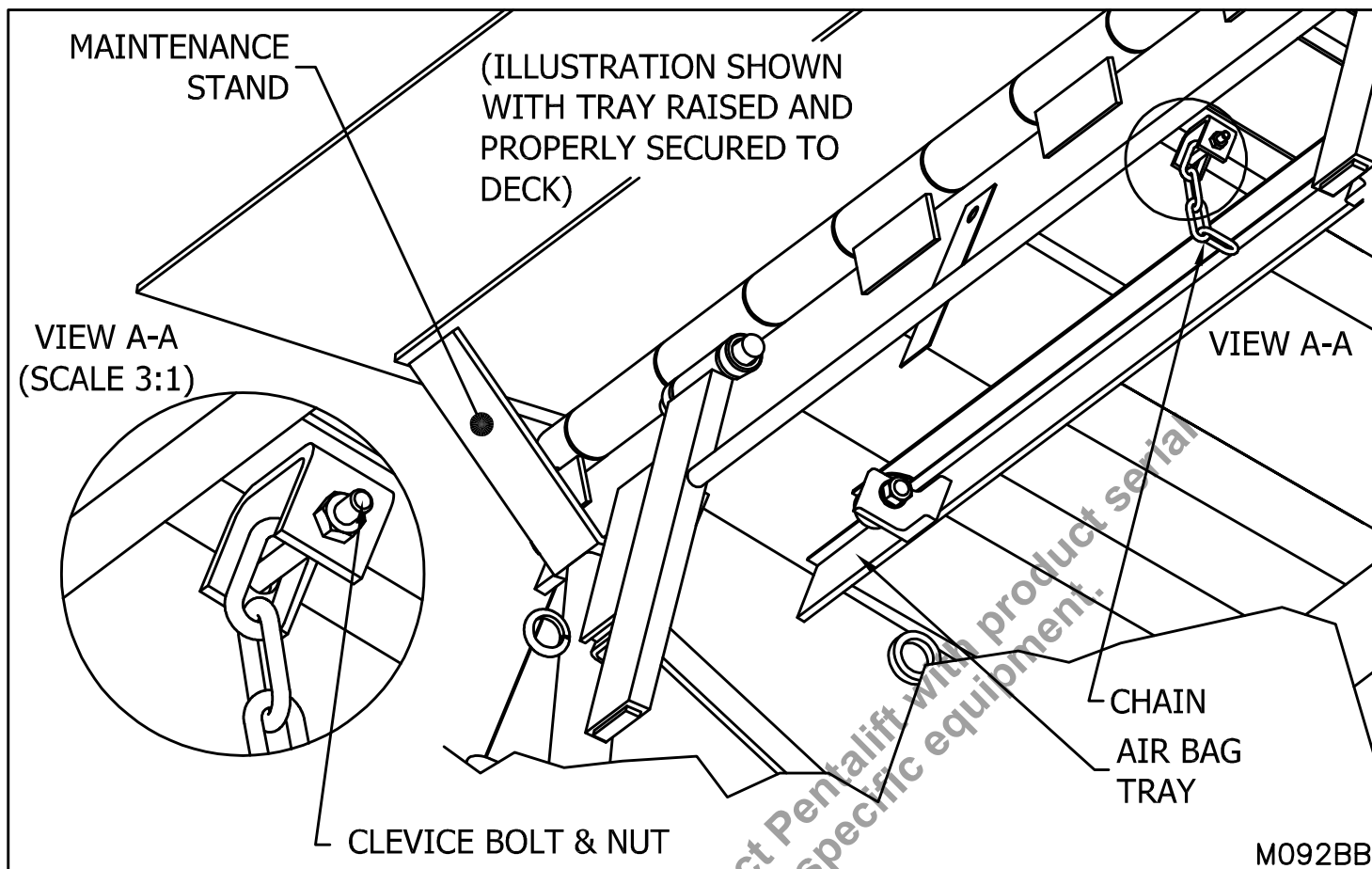

Figure 51B: Lifting and supporting the Air Bag Tray

Lifting and supporting the Air Bag Tray

1. Follow procedure as outlined in the section **“SUPPORTING THE LEVELER FOR MAINTENANCE”**.
2. When the Air Powered Dock Leveler has been properly secured and locked out, place a suitable lifting device such as a jack with sufficient travel between the underside of the tray and pit floor. Jack to raise the air bag tray so that the clevis bolt and chain can be secured as shown in “Figure 51B: Lifting and supporting the Air Bag Tray” on page 53.
3. Slip the clevis bolt through the chain loop and secure with the nut at the front edge of the tray as shown in “Figure 51B: Lifting and supporting the Air Bag Tray” on page 53.
4. **NEVER** go underneath the dock leveler / tray until it is fully secured to the underside of the deck with the clevis bolt & nut.
5. With the Air Bag tray now secured maintenance person now has access to the Blower Motor assembly for routine maintenance such as cleaning the “Air Filter” or replacement of the blower motor.

Disengaging the Air Bag Tray (Maintenance work completed, restoring to full operation)

1. Ensure **NO TOOLS OR OTHER OBSTRUCTIONS** are in the pit area impeding the proper function and working space of the Air Bag Dock Leveler.
2. With the jack supporting the air bag tray, remove the nut from the clevis bolt. Slide the clevis bolt out releasing the chain and lower the jacking device until the tray has been fully lowered to its normal operating position.
3. Now follow the procedures outline on **“DISENGAGING THE MAINTENANCE STAND”** on page 52

ADJUSTABLE LIP STOP

The lip stop for all capacities 30,000 through 50,000 lbs is adjustable. The lip stop stops the lip in the correct location when moving the dock leveler into the stored position. The threaded adjustment mechanism consists of a 5/8-11 bolt mounted through the headboard along with two 5/8-11 adjustment nuts.

NOTE: Proper adjustment is made at the factory and typically won't require further adjustment. Do not attempt any adjustments unless you are confident that adjustment is required.

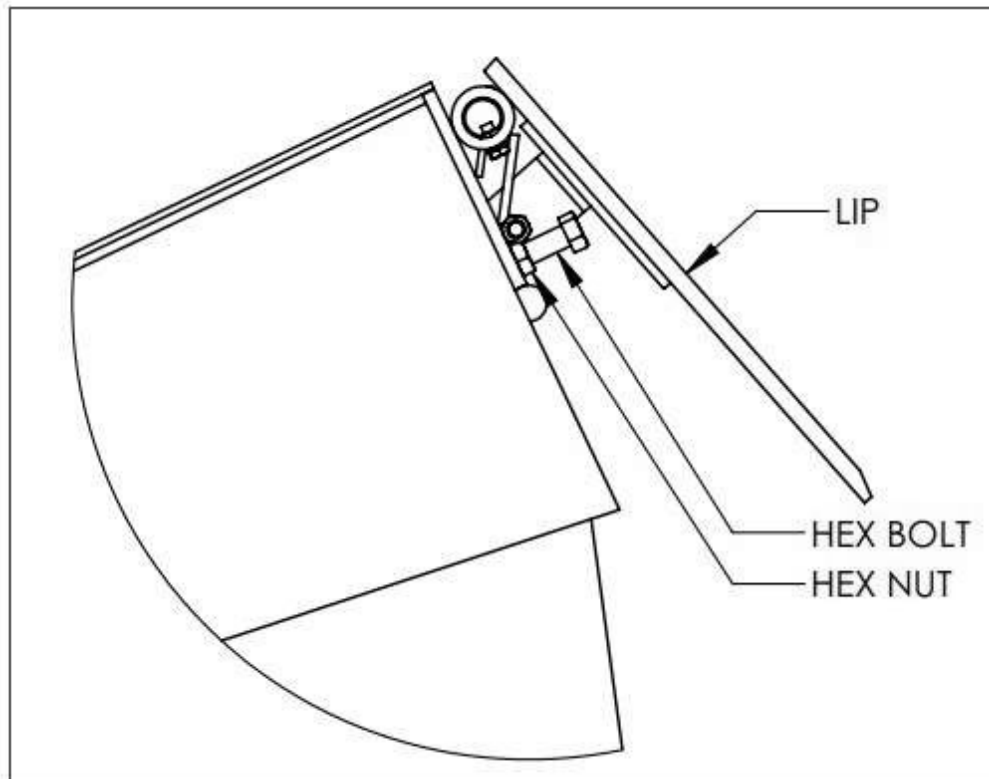

Figure 67: Adjustable Lip Stop

TROUBLE SHOOTING GUIDE

NOTE: This equipment has been fully tested and confirmed to be operational at the factory. Historically, the majority of operating problems are caused by unnecessary tampering by unqualified personnel. To conform to the terms of the Warranty, contact your authorized Pentalift representative if you are having any difficulty with the leveler during the warranty period. Do not risk voiding the warranty by tampering with the equipment.

NOTE: A very high level of field issues with this type of equipment can be directly attributed to improper or incomplete installation. The installation instructions and information provided for this equipment is thorough. A step by step sequence for installation is provided. All steps must be followed and completed to provide a complete installation. Incomplete or improper installations can lead to equipment malfunction, create safety issues and / or damage and void warranties. Please follow all installation and setup steps as indicated in the installation instructions and owners manual. If you are unclear or uncertain regarding any of the steps contact your Pentalift representative for clarification. A copy listing the steps completed including the sign off and photos of the installation as outlined in the installation instructions, will be required prior to any assistance by Pentalift factory personnel for trouble shooting.

DANGER

Before doing any installation, maintenance, inspection or trouble shooting, barricade all areas from traffic around the work area inside (and outside if applicable) for safety and post appropriate warning signs.

DANGER

BEFORE DOING ANY ELECTRICAL WORK, BE CERTAIN THAT THE POWER IS DISCONNECTED WITH A FUSED DISCONNECT, PROPERLY TAGGED AND LOCKED OUT. FUSED DISCONNECT AND LOCKOUT DEVICE (SUPPLIED AND INSTALLED BY OTHERS) MUST MEET WITH ALL APPLICABLE CODES AND REGULATIONS. ALL ELECTRICAL WORK MUST BE PERFORMED BY A QUALIFIED ELECTRICIAN IN ACCORDANCE WITH ALL APPLICABLE CODES AND REGULATIONS. ALL OTHER REPAIRS SHOULD BE DONE BY A TRAINED AUTHORIZED PENTALIFT REPRESENTATIVE.

DANGER

NEVER GO BENEATH THE DOCK LEVELER FOR ANY REASON UNLESS THE DECK AND LIP ARE PROPERLY SUPPORTED (SEE "SUPPORTING THE LEVELER FOR MAINTENANCE" on page 49) AND THE POWER IS DISCONNECTED WITH A FUSED DISCONNECT, PROPERLY TAGGED AND LOCKED OUT. IT IS THE RESPONSIBILITY OF THE OWNER TO ENSURE THAT NO LOAD OR TRAFFIC IS PLACED ON THE DECK WHILE THE MAINTENANCE STAND IS ENGAGED. THE CONSTRUCTION OF THE MAINTENANCE STAND IS INTENDED TO SUPPORT THE WEIGHT OF THE UNLOADED DOCK LEVELER ONLY.

DANGER

Arc flash and shock hazard PPE (personal protection equipment) required. De-energize equipment before working on or inside. Do not open cover without appropriate PPE. Refer to NFPA 70E for PPE requirements. This panel may contain more than one power source. Hazardous voltage will cause severe injury or death.

The Air Powered Dock Leveler functions through the use of stored spring and electrical energy. On your Pentalift Air Powered Dock Leveler there is one area where spring energy is utilized; spring energy is utilized in the lip actuator assembly extending and locking the lip. Under-adjustment of the lip assist spring will cause the lip to be effectively too heavy for the extension mechanism. Over-adjustment of the lip assist spring will cause the lip to be effectively too light and may create a situation where the lip will not retract to its storing position upon truck departure. Refer to "LIP ASSIST SPRING ADJUSTMENT" on page 60 on p"ADJUSTMENTS" on page 59.

Your Pentalift Air Powered Dock Leveler has been shipped from the factory adjusted for trouble free performance. It is important to understand because this is an electro-mechanical device, a "balance" between various mechanisms is required for proper operation. Improper adjustment can deteriorate the performance of your dock leveler and create dangerous situations. Never extend the length of the lip chain. **Any adjustments must be made by factory authorized service technicians.**

1. **Blower does not run when push button is engaged.**
 - a) Check circuit breaker or fuses at the main power supply and at the disconnect.
 - b) Check for loose wires in the control panel.
 - c) Check to ensure all connections made match the wiring diagram (supplied with the control panel).
 - d) If the issue cannot be solved, consult your authorized Pentalift representative.
2. **Blower motor runs but deck does not raise and or lip will not extend.**
 - a) Check for debris or obstruction that may interfere with the operation of any moving part.
 - b) Check to make sure air filter for blower is clean.
 - c) Check and make sure impeller of blower has not be damage. If a rattling noise is present, there is a good chance that the impeller has been damaged
 - d) The Air Bag may have a cut or may be damaged in some way.
 - e) If the issue cannot be solved, consult your authorized Pentalift representative.
3. **The lip will not return to pendant position**
 - a) Inspect lip spools for debris or obstruction.
 - b) Grease the lip. (See "MAINTENANCE AND LUBRICATION" on page 57)
 - c) Lip assist spring out of adjustment. Refer to "LIP ASSIST SPRING ADJUSTMENT" on page 60
 - d) If the issue cannot be solved, consult your authorized Pentalift representative.
4. **Main breaker or overload relay is tripping.**
 - a) Check for a short circuit in the wiring.
 - b) Check all wire connections and assure the unit is wired according to the wire diagram supplied with the control panel.
 - c) If the issue cannot be solved, consult your authorized Pentalift representative.
5. **Lip extends but will not lock into position**
 - a) Check for debris or obstruction that may interfere with the operation of any moving part in the lip hinge or lip operating assembly.
 - b) Refer to "LIP ASSIST SPRING ADJUSTMENT" on page 60 for proper adjustment.
 - c) Refer to item #2 above.
 - d) If issue cannot be solved, consult your authorized Pentalift representative.

If damaged or worn parts are detected upon inspection, replacement must be undertaken **immediately**. **The Dock leveler must not be used until replacement is completed.** Parts are readily available from your Pentalift representative.

INSTALLATION, INSPECTION, MAINTENANCE AND LUBRICATION

UNLESS OTHERWISE NOTED, THE FOLLOWING MAINTENANCE AND INSPECTION PROCEDURES SHOULD BE CONDUCTED AT A MINIMUM OF EVERY 30 DAYS. INCREASE FREQUENCY FOR MORE SEVERE ENVIRONMENTS.



WARNING Importance of following installation instructions: A very high level of field issues with this type of equipment can be directly attributed to improper or incomplete installation. The installation instructions and information provided for this equipment is thorough. A step by step sequence for installation is provided. All steps must be followed and completed to provide a complete installation. Incomplete or improper installations can lead to equipment malfunction, create safety issues and / or damage and void warranties. Please follow all installation and setup steps as indicated in the installation instructions and owners manual. If you are unclear or uncertain regarding any of the steps contact your Pentalift representative for clarification. A copy listing the steps completed including the sign off and photos of the installation as outlined in the installation instructions, will be required prior to any assistance by Pentalift factory personell for trouble shooting assistance.



DANGER Importance of inspection, monitoring and correcting structural damage: The deck, lip and frame assemblies of the dock leveler are structurally subjected to loads on going. It is important to regularly visually inspect the dock levelers structurally for signs of damage or wear. Damage could be in the form of distorted, cracked or broken structural members or welds. Areas to review include but are not limited to; lip and headboards tubes, deck beam adhesion to the head board, deck plate and tail board and rear frame attachment to rear curb angle. Any damage or signs of cracking, etc. should be noted and addressed immediately. Immediate attention and action to address issues of this nature generally results in simple repairs. Issues that are left unchecked and / or unaddressed result in significant repairs and even entire replacement as well as a serious critical failure resulting in serious injury or death. If structural issues are detected use of the equipment is to be discontinued until the appropriate corrections or alterations are made. continued use will result in further damage and potentially dangerous equipment failure. The frequency of reviews should be a maximum of every 30 days. The frequency should be increased for higher frequency and use applications i.e. multiple shifts or high traffic loading docks. For assistance and guidance in evaluating and correcting structural damage, contact your Pentalift representative.



DANGER BEFORE DOING ANY INSTALLATION, MAINTENANCE, INSPECTION OR TROUBLE SHOOTING, BARRICADE ALL AREAS FROM TRAFFIC AROUND THE WORK AREA INSIDE (AND OUTSIDE IF APPLICABLE) FOR SAFETY AND POST APPROPRIATE WARNING SIGNS. NEVER GO BENEATH THE DOCK LEVELER FOR ANY REASON UNLESS THE DECK AND LIP ARE PROPERLY SUPPORTED (SEE "SUPPORTING THE LEVELER FOR MAINTENANCE" on page 49) AND THE POWER IS DISCONNECTED WITH A FUSED DISCONNECT, PROPERLY TAGGED AND LOCKED OUT. IT IS THE RESPONSIBILITY OF THE OWNER TO ENSURE THAT NO LOAD OR TRAFFIC IS PLACED ON THE DECK WHILE THE MAINTENANCE STAND IS ENGAGED. THE CONSTRUCTION OF THE MAINTENANCE STAND IS INTENDED TO SUPPORT THE WEIGHT OF THE UNLOADED DOCK LEVELER ONLY.



Arc flash and shock hazard PPE (personal protection equipment) required. De-energize equipment before working on or inside. Do not open cover without appropriate PPE. Refer to NFPA 70E for PPE requirements. This panel may contain more than one power source. Hazardous voltage will cause severe injury or death.

NOTE: Read the SAFETY INFORMATION AND WARNINGS before servicing the dock leveler. (See page ii)

NOTE: It is the owner's responsibility to assure that all labeling remains legible and in its original position throughout the life of the product. (See "SAFETY LABELING" on page 50)

NOTE: Inspect equipment for protective coatings (i.e. paint) that has deteriorated or been removed. Prepare affected area and reapply protective coating as required.

NOTE: Inspect the equipment for structural damage as detailed on page 57

NOTE: At every maintenance interval, inspect the Dock Leveler for any damage or worn parts. If any damaged or worn parts are found, discontinue use of the dock leveler and repair immediately.

LUBRICATION:

Weekly: Once a week, or after repetitive operation, inspect the air bag for premature wear or is showing signs of tearing.

Monthly: The recommended lubrication **service interval is every 30 days** or at a greater frequency as required in severe environments. **Dexron III Automatic Transmission Fluid** is recommended. Use EP2 Multi-purpose grease or equivalent to lubricate the area that makes contact between lip yield clevis assembly, the yield mechanism assembly, and tray rear hinge bar (See "Figure 60: Lubrication Points" on page 58 for lubrication points). It is strongly urged that a maintenance log be maintained with the dates of monthly inspections, the name of the inspector and the results of the inspection.

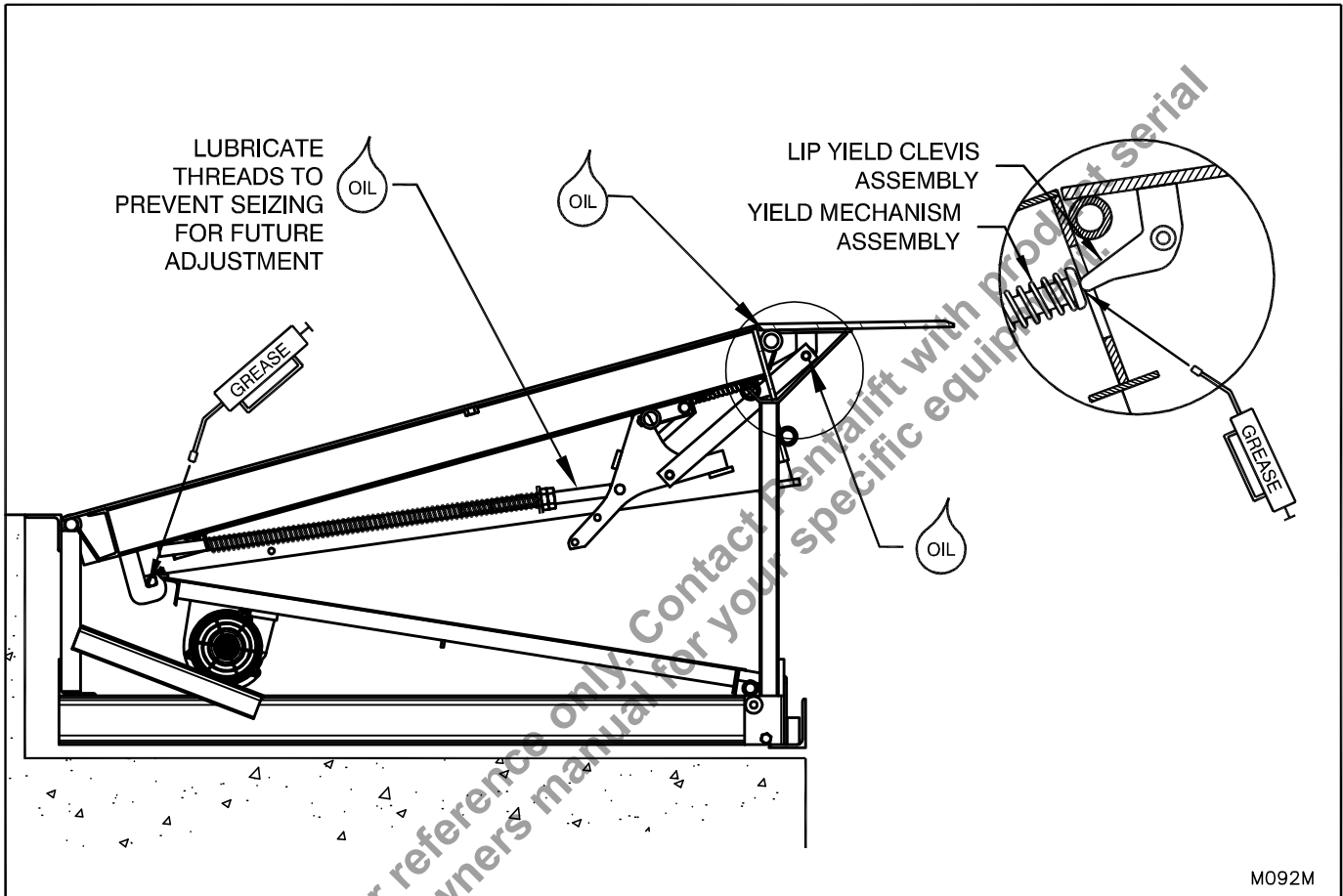

Figure 60: Lubrication Points

BLOWER:

Quarterly: The air filter must be checked every three months to ensure that it is clean with minimal debris or dirt present. The frequency will depend on the environmental conditions. A dirty filter will prevent the dock leveler from functioning properly. To perform this operation the dock leveler must be properly supported and the tray secured to the underside of the deck ("Figure 59: Proper Placement of Maintenance Stand" on page 50 and "Figure 51B: Lifting and supporting the Air Bag Tray" on page 53).

1. Loosen the gear clamp, holding the filter assembly on the blower.
2. Inspect the outward facing surface of the Air Filter Assembly. ("Figure 61: Blower Assembly Replacement Parts" on page 64) If dirt or debris is present replace with a new air filter (Available through your Pentlift representative). Alternatively it can be cleaned with an air pressure line, blowing from the inside portion of the filter assembly through the filter away from your body. Ensure you **DO NOT** blow the high pressure air in the direction of your skin or in the direction of any other persons.

ADJUSTMENTS



ONLY TRAINED AND QUALIFIED PERSONNEL ARE TO PERFORM INSPECTION OR MAINTENANCE AND SERVICE PROCEDURES.



BEFORE DOING ANY INSTALLATION, MAINTENANCE, INSPECTION OR TROUBLE SHOOTING, BARRICADE ALL AREAS FROM TRAFFIC AROUND THE WORK AREA INSIDE (AND OUTSIDE IF APPLICABLE) FOR SAFETY AND POST APPROPRIATE WARNING SIGNS. NEVER GO BENEATH THE DOCK LEVELER FOR ANY REASON UNLESS THE LIP AND DECK ARE PROPERLY SUPPORTED BY THE MAINTENANCE STAND (SEE “SUPPORTING THE LEVELER FOR MAINTENANCE” on page 49). IT IS THE RESPONSIBILITY OF THE OWNER TO ENSURE THAT NO LOAD OR TRAFFIC IS PLACED ON THE DECK WHILE THE MAINTENANCE STAND IS IN USE. THE CONSTRUCTION OF THE MAINTENANCE STAND IS INTENDED TO SUPPORT THE WEIGHT OF THE UNLOADED DOCK LEVELER ONLY.

DO NOT PERFORM ANY ADJUSTMENTS UNTIL THE PIT AND LEVELER ARE CLEANED, CHECKED FOR OBSTRUCTIONS AND THAT ALL PROPER LUBRICATION IS COMPLETED. REFER TO “MAINTENANCE AND LUBRICATION” on page 57.

NORMAL SEQUENCES OF STEPS TO ADJUST MECHANICAL DOCK LEVELER THAT IS NOT PROPERLY FUNCTIONING

Whenever there is an issue with the operation of the mechanical dock leveler the following steps should be completed.

Note: The dock levelers are tested and set up at the factory. Over time, springs take a set and change in tension. As well site conditions and the friction of weather seal (if provided) can affect the required adjustments on the dock levelers.

1. Confirm that lip hinge assembly is free from debris and obstructions. Concrete, stucco, parging materials, nails, screws, pieces of wood from pallets and skids and other debris can be present at the hinge assembly. Any debris of this nature can inhibit the proper operation by creating additional friction or impediments to lips rotational engagement movement. Debris of this nature should be removed on a regular ongoing basis. The user of the equipment should be made aware of this concern and the need to clean and maintain this aspect of the dock leveler on a regular basis.
2. Make sure the dock leveler lip hinge assembly is properly lubricated in accordance with the owner’s manual instructions (see “MAINTENANCE AND LUBRICATION” on page 57).
3. Make sure the dock leveler lip spring adjustment is set at the correct level as the instructions on (see “LIP ASSIST SPRING ADJUSTMENT” on page 60). This is a vital adjustment. Proper adjustment of the lip assist spring will allow the lip spring adjustment to be minimized and avert the issues listing item 1 above.

LIP ASSIST SPRING ADJUSTMENT

Note: This is a very important adjustment that is often not understood or properly set up.

Note: On deck levelers with lighter lips additional spring assist tension is not required and therefore the lip spring bar is provided with no threads for adjustment. For dock levelers of this configuration lip tension adjustment is not provided.

The purpose of the lip assist spring adjustment is to provide a means of compensating for the dock leveler lip weight to the point that the dock leveler lip is downward bias but with a lower level of downward bias. The benefit of proper adjustment of the lip assist spring is that it reduces the lift spring tension required in order to make the dock leveler properly function and extend and lock the lip when the dock leveler is activated.

Adjusting the lip assist spring with too much spring tension will result in the lip not having sufficient downward bias to move to the pendent and parked position and to fully retract behind the lip keepers when the dock leveler is in the stored position. Too little lip assist spring adjustment may result in one or more of the following issues:

- 1) When the dock leveler is activated from the stored / parked position the dock leveler lip assembly will not rotate sufficiently high to allow full locking activation of the lip into the extended position. This puts the dock leveler in a condition where it is not usable.
- 2) The air bag may not have sufficient lifting force to fully extend the lip.

To adjust the lip assist spring, release the lock nut and advance the adjustment nut clockwise 1 to 2 turns at a time (See "Figure 53A: Lip Spring Adjustment" on page 61) to produce the appropriate tension to allow the lip to extend and lock the lip while still allowing the lip to fully fall to the pendant position when the lip is released. To determine when sufficient spring tension adjustment has been achieved hold the dock leveler lip at 45 degrees. It should take approximately 15 to 20 lbs of force maximum to hold the lip from falling when in this position. If the force is more add more lip assist spring tension if the force is less remove lip assist spring tension. Also confirm that from the 45 degree position when the lip is released (let go) by hand, it will fall to the fully pendant position. If it does not then remove lip assist spring tension.

Note: The length of the lip chain at the front of the dock leveler is preset at the factory. The length of this chain must not be altered. Lengthening of the chain will allow the deck to over-travel causing the lifting arm roller to roll off the back of the cam. Shortening the chain will interrupt the dock levelers lip extension or cause the lip to extend too early resulting in a lowered above level service range for the dock leveler.

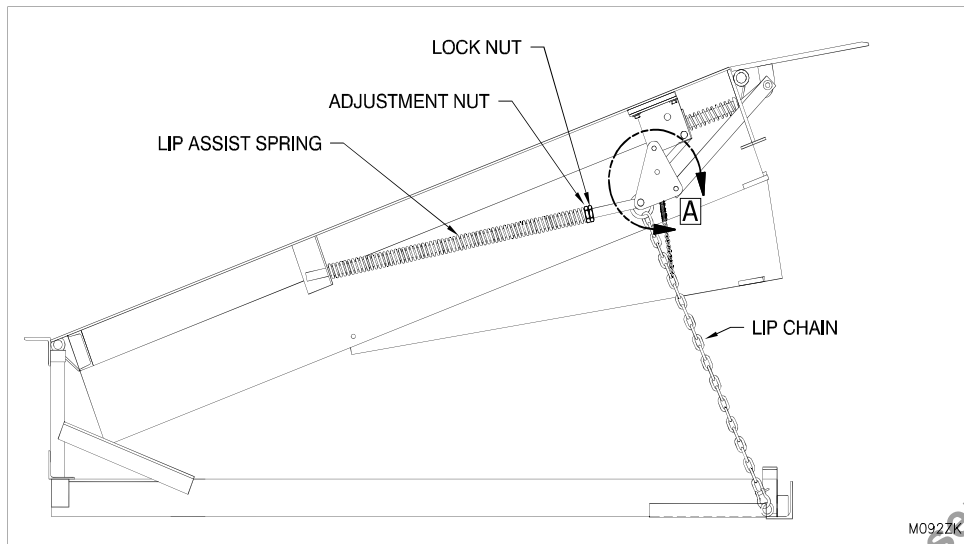

Figure 53A: Lip Spring Adjustment

LIP YIELD MECHANISM

Lip Actuator and Lip Assist Chain connections and routings;

Visually confirm that the component, spring and chain arrangements and routing paths shown in these illustrations exist on the subject dock leveler (see “Figure 66: Chains and Spring connection and routing for Lip Yieldable Mechanism” on page 62 and “Figure 64: Chains and Spring Components” on page 63). If anything is missing or appears damaged then repair or replace to match the arrangement shown here. Look for damaged or worn springs or spring connections.

Note: The length of the lip chain at the front of the dock leveler is preset at the factory. It is important that the length of this chain not be altered. Lengthening of the chain could allow the deck to over-travel causing the lifting arm roller to roll off the back of the cam and other functional issues. Shortening the chain will reduce the above level range of the dock leveler as well as cause other functional issues.

The following is the lip chain length for the various dock leveler length:

1. For a 6 feet long dock leveler, the lip chain length is 30 5/8 inches nominal.
2. For a 8 feet long dock leveler, the lip chain length is 35 1/2 inches nominal.

The following is the deck stop chain length for the various dock leveler length:

1. For a 6 feet long dock leveler, the lip chain length is 41 inches nominal.
2. For a 8 feet long dock leveler, the lip chain length is 46 3/4 inches nominal.

The tolerances on the lip chain length is +3/8 and -1/4 inches.

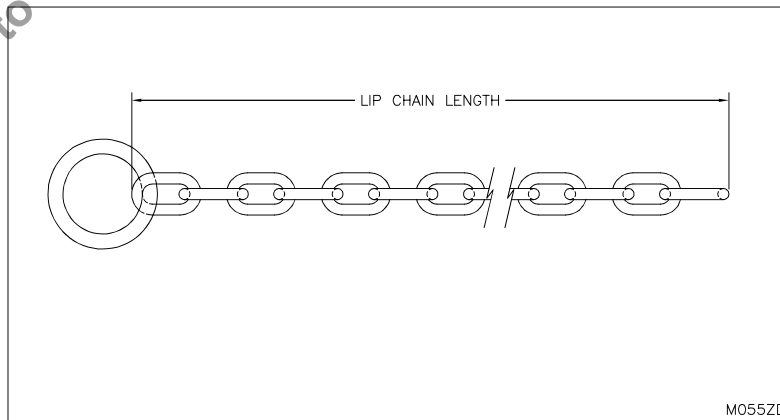

DETAIL "A"

(CONNECTION/ROUTING OF SPRINGS AND CHAINS)

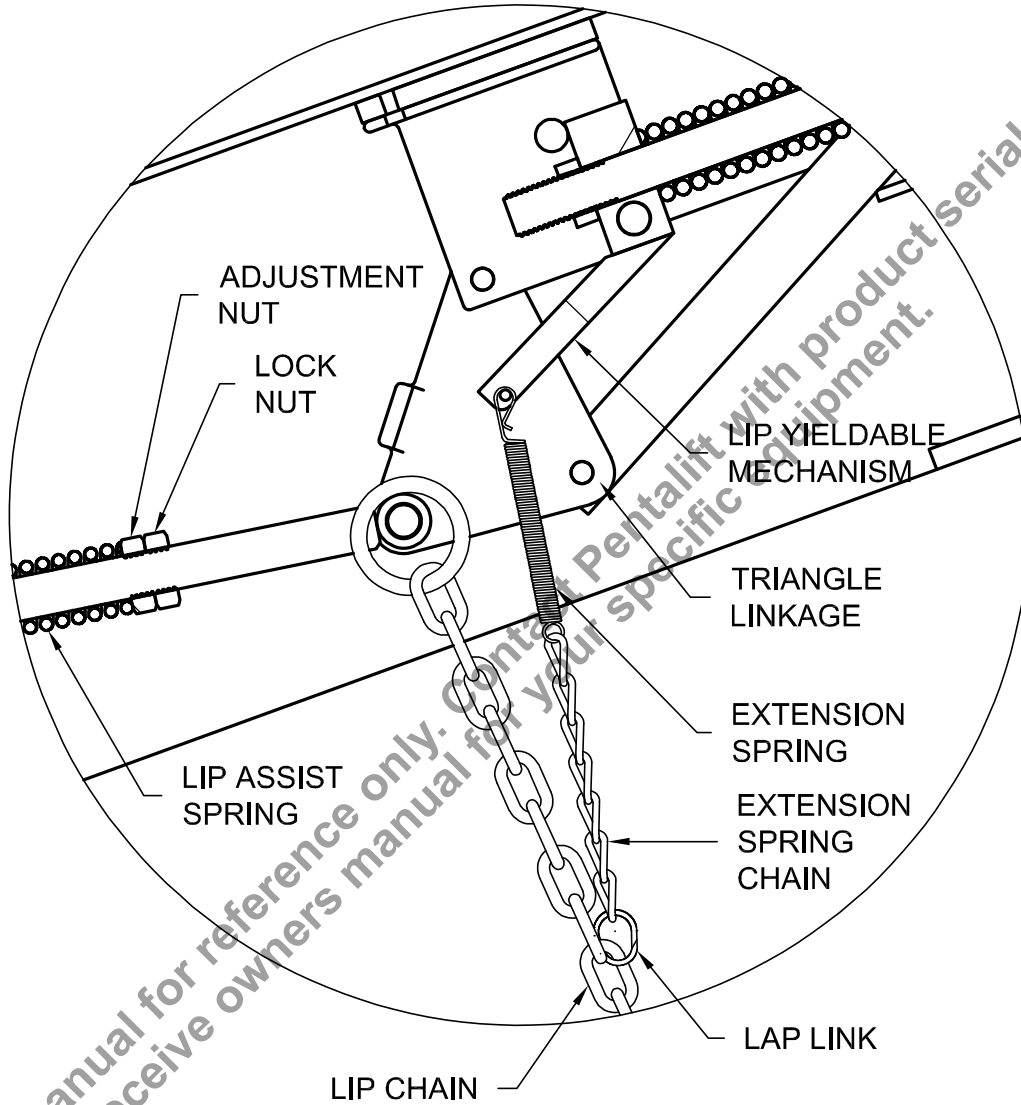

M055ZF

Figure 66: Chains and Spring connection and routing for Lip Yieldable Mechanism

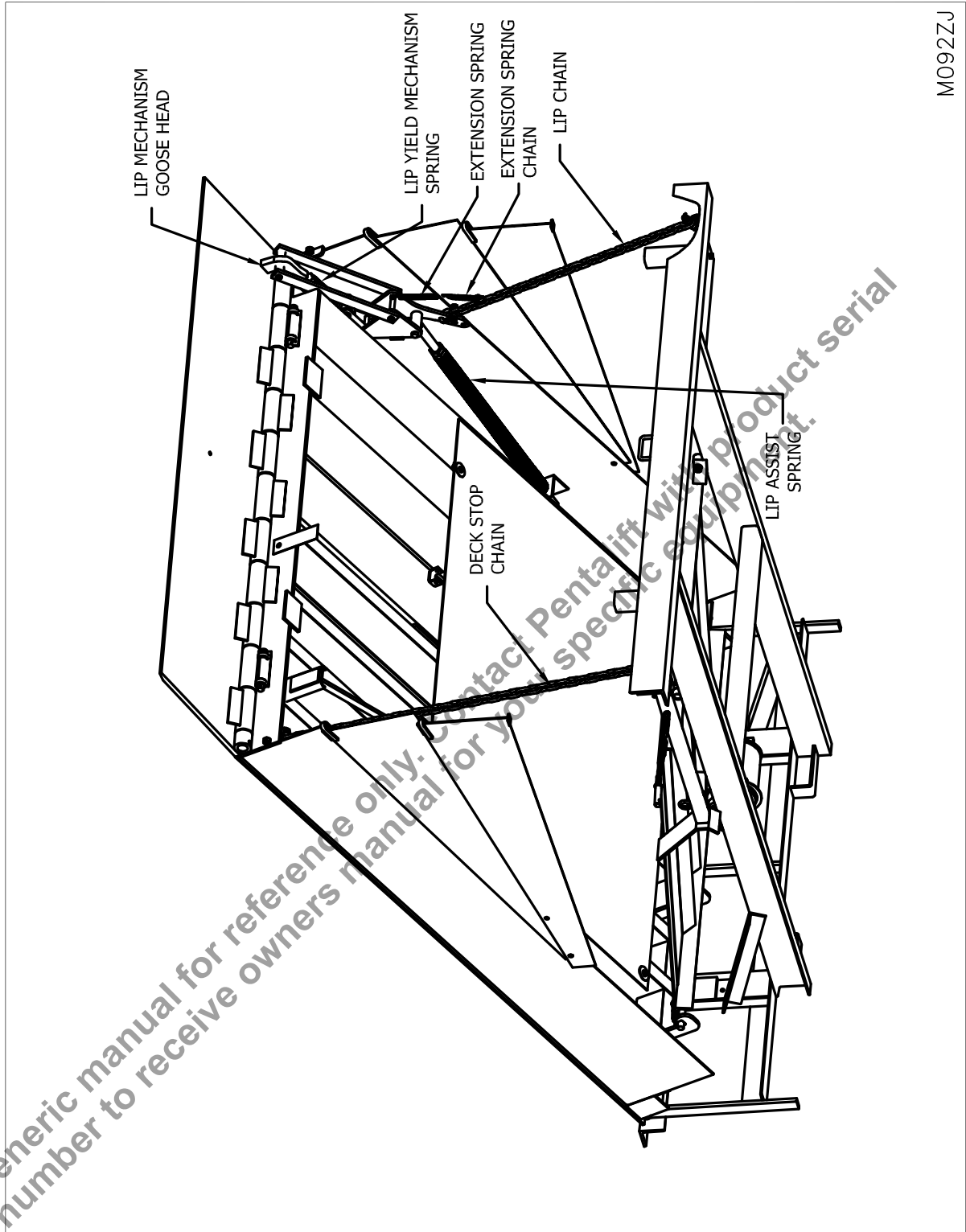

M092ZJ

Figure 64: Chains and Spring Components

REPLACEMENT PARTS

USE ONLY GENUINE PENTALIFT REPLACEMENT PARTS



To ensure proper functioning, durability and safety of the product, only genuine pentlift replacement parts must be used. Altering the product from its original manufactured configuration must not be done. Pentlift equipment Corporation disclaims all liability for failure to comply with this warning. Warranties are specifically disclaimed in the event the purchaser fails to comply with this warning.

To expedite order processing when ordering parts, provide the following information to your Pentlift representative:

1. Model and Serial Number of equipment.
2. Part Number, Description and Quantity.
3. Shipping Instructions.

BLOWER ASSEMBLY REPLACEMENT PARTS

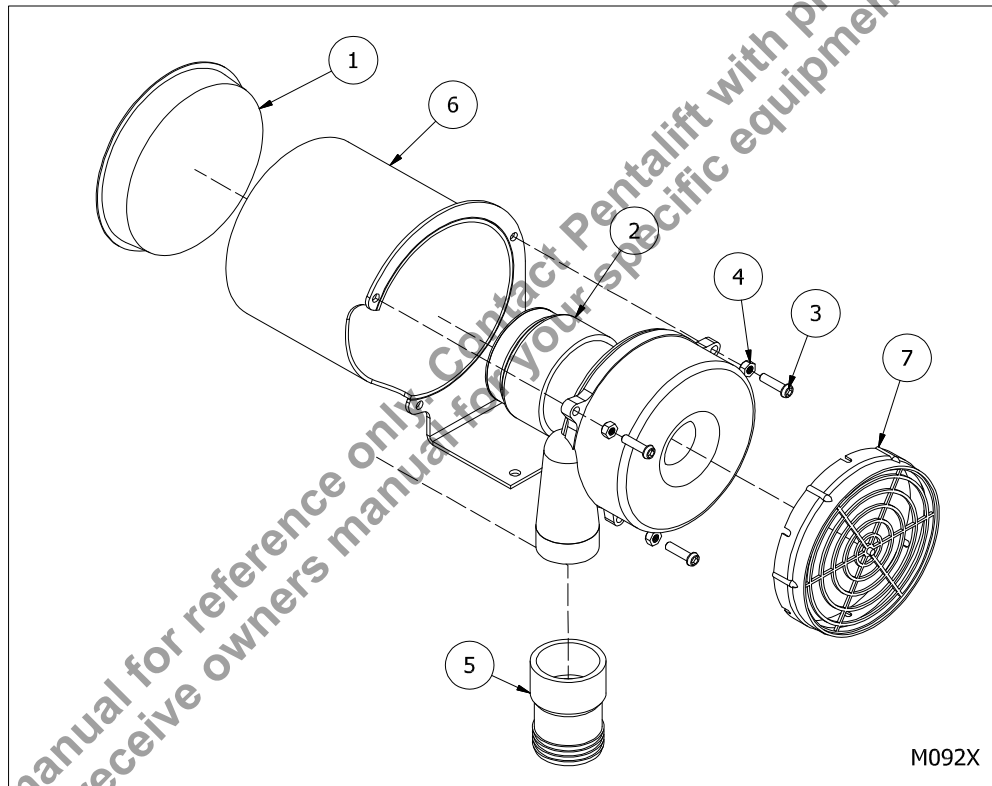

Figure 61: Blower Assembly Replacement Parts

<u>Item #</u>	<u>Part No.</u>	<u>Description</u>
1	0960053	End Plug
2	0600969	Blower
3	0720042	Screw
4	0700018	Nut
5	0960054	Barbed Connector
6	8023450	Blower Housing Assembly
7	0960055	Air Filter Assembly
8	0600457	Strain Relief (Not Shown)
9	0880005	Gear Clamp (Not Shown)

NOTE: State Model # and Serial # when ordering replacement parts.

REPLACEMENT PARTS

USE ONLY GENUINE PENTALIFT REPLACEMENT PARTS

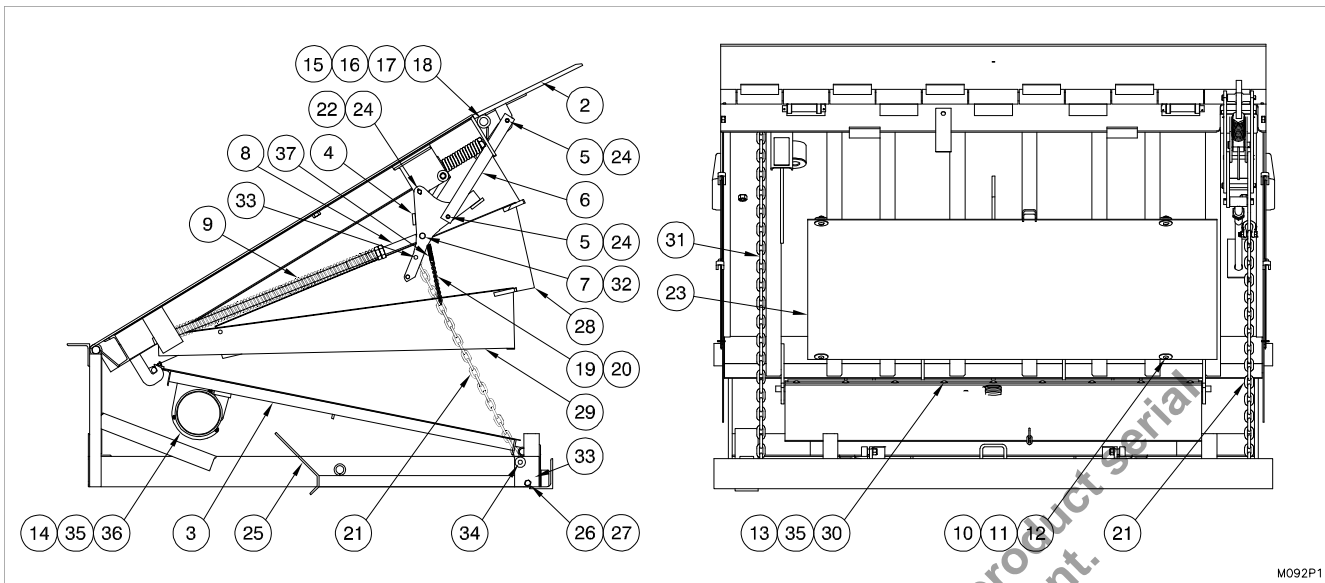

Figure 62: Replacement Parts

Item #	Part No.	Description
1	NOTE	Air Bag (Not Shown for Clarity)
2	NOTE	Lip Assembly
3	NOTE	Air Bag Rolling Tray
4	8023500	Linkage Mechanism
5	3021023	Middle Linkage Pin
6	3021458	Middle Linkage Arm
7	3021026	Lip Assist Rod Pin
8	8021828	Lip Assist Weldment
9	3021004	Lip Assist Spring
10	0700085	Nut
11	0720375	Bolt
12	0740115	Washer
13	3029040	Clamping Bar
14	8023448	Blower Assembly
15	NOTE	Lip Pin
16	0720018	Lip Pin Retaining Bolt
17	0700013	Lip Pin Retaining Nut
18	0740025	Lip Pin Retaining Washer
19	3021085	Extension Spring Chain
20	0870159	Lapl Link
21	NOTE	Lip Chain
22	3021025	Triangle Linkage Pin
23	NOTE	Upper Support Plate
24	0820001	Cotter Pin
25	8023446	Maintenance Stand
26	0720092	Screw
27	0700017	Nut
28	NOTE	Sliding Skirt
29	NOTE	Second Sliding Skirt
30	0720378	Carriage Bolt
31	NOTE	Deck Stop Chain
32	0820010	Cotter Pin
33	0870161	Shackle
34	8023457	Maintenance Stand Pin
35	0700085	Nut
36	0740016	Washer
37	3029100	Extension Spring

NOTE: State Model # and Serial # when ordering replacement parts.

OPTIONAL FALLSAFE REPLACEMENT PARTS

USE ONLY GENUINE PENTALIFT REPLACEMENT PARTS

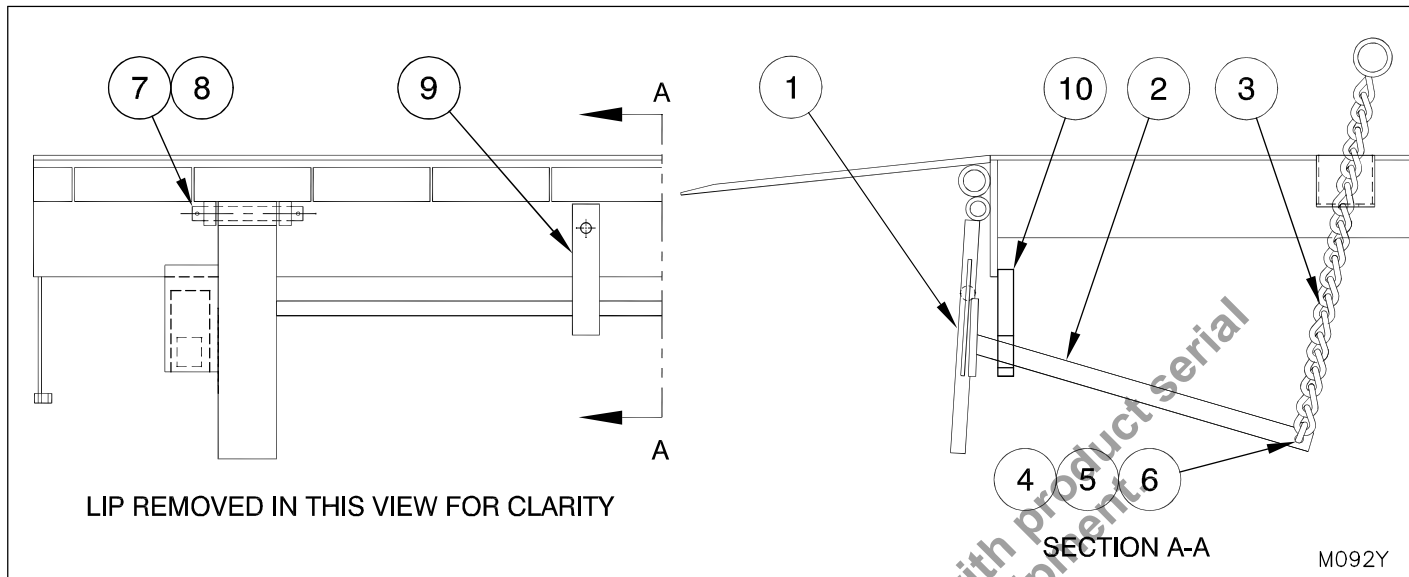

Figure 63: Optional Fallsafe Replacement Parts

<u>Item #</u>	<u>Part No.</u>	<u>Description</u>
1	8023451	Fallsafe Leg Assembly
2	8022751	Below Level Push Arm Assembly
3	8021026	Pull Chain Assembly
4	0720201	Bolt
5	0700056	Nut
6	0740005	Washer
7	3020634	Pin
8	0820010	Cotter Pin
9	3021154	Spring Bar
10	3021497	Push Arm Support Plate

NOTE: State Model # and Serial # when ordering replacement parts.

CONTROL PANEL REPLACEMENT PARTS

USE ONLY GENUINE PENTALIFT REPLACEMENT PARTS

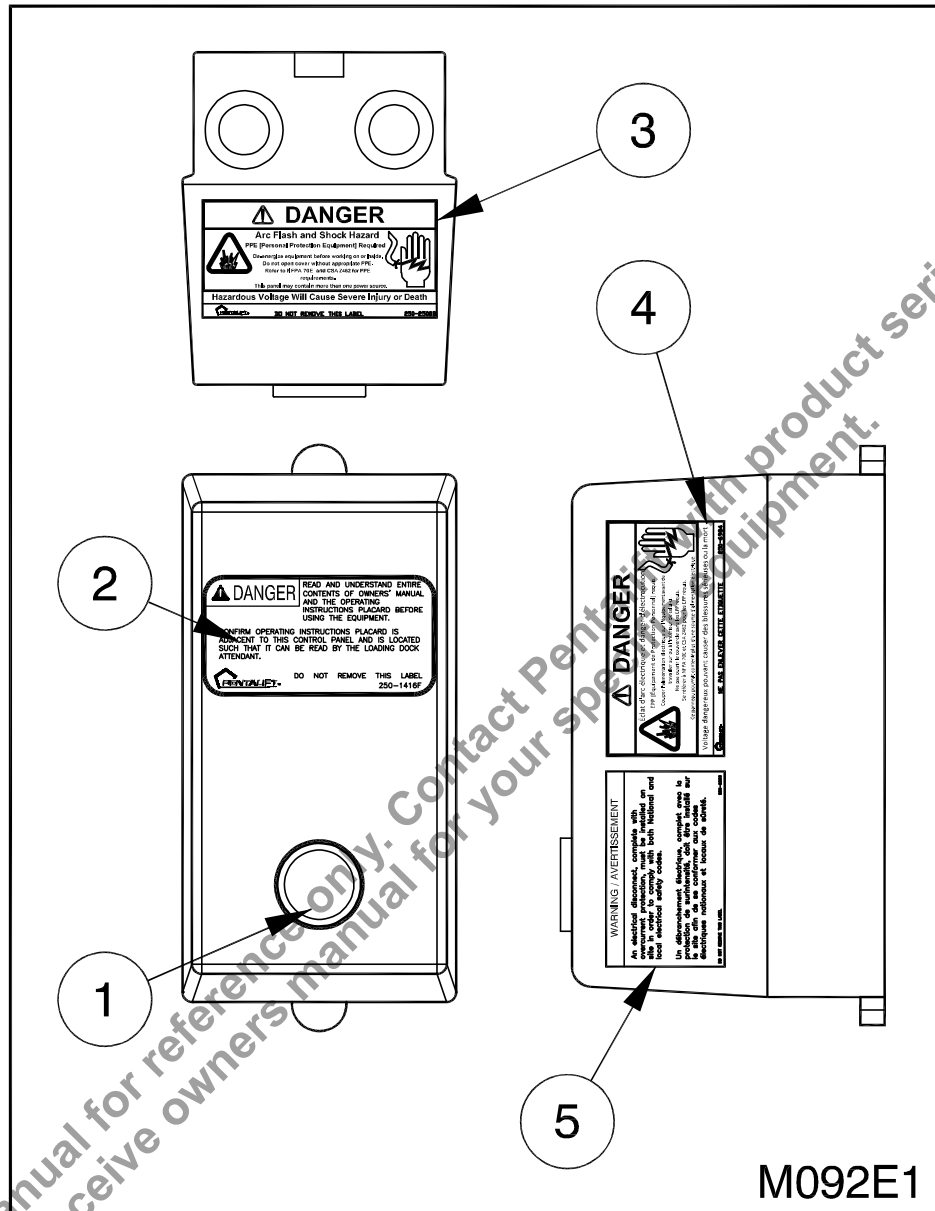

M092E1

Figure 63: Control Panel - Basic Model (Jog Start)

<u>Item</u>	<u>Part No.</u>	<u>Description</u>
1	060-0970	Jog Start Control Box
2	250-1416	Label for Jog Start Control Box
3	250-2508	Label Arc Flash - English
4	250-6984	Label Arc Flash - French
5	250-2296	Label Electrical Disconnect

NOTE: State Model # and Serial # when ordering replacement parts.

DRAWING NO. 061-1383

REV	REV. DATE	REVISION DESCRIPTION	BY
A	1/2/2017	UPDATE WIRING	BV

FIELD WIRING INSTRUCTIONS

CONNECT THE LINE SUPPLY LEAD (L) TO CONTACTOR TERMINAL 5
 CONNECT THE NEUTRAL LEAD (N) TO CONTACTOR TERMINAL 3
 CONNECT A JUMPER BETWEEN CONTACTOR TERMINAL 3 AND A2
 CONNECT A JUMPER BETWEEN CONTACTOR TERMINAL A1 AND PUSH BUTTON TERMINAL 4

IF AN OVERHEAD DOOR LIMIT SWITCH IS PURCHASED OR PROVIDED, CONNECT THE OVERHEAD DOOR LIMIT SWITCH SUPPLY LEAD TO CONTACTOR TERMINAL 5 AND OVERHEAD DOOR LIMIT SWITCH SIGNAL LEAD TO PUSH BUTTON TERMINAL 3

IF AN OVERHEAD DOOR LIMIT SWITCH IS NOT PURCHASED OR PROVIDED, CONNECT A JUMPER BETWEEN CONTACTOR TERMINAL 5 AND PUSH BUTTON TERMINAL 3

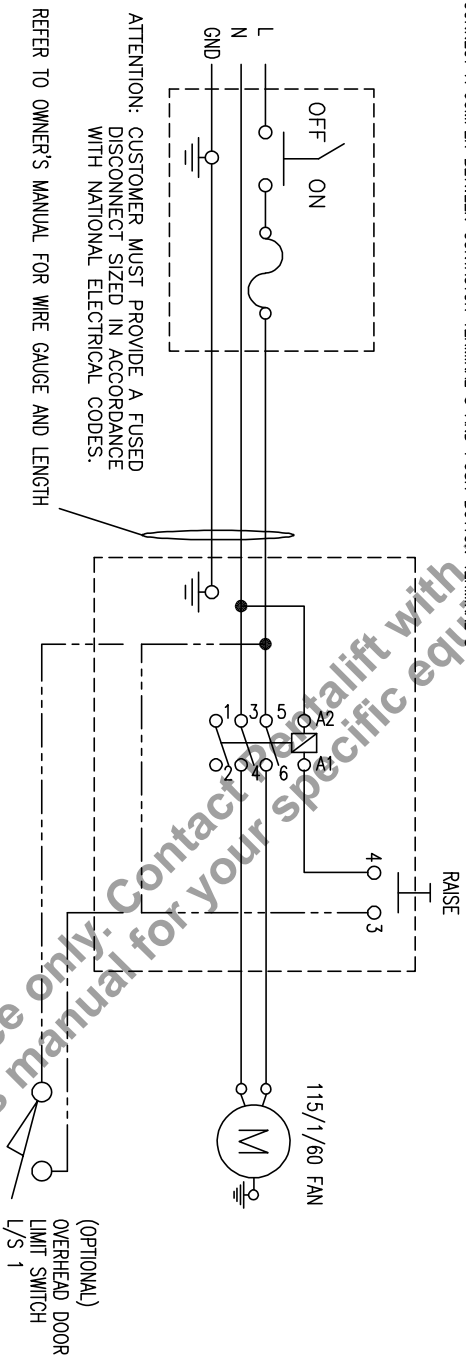

REFER PANEL LAYOUT 161-0418

PENTALIFT PENTALIFT EQUIPMENT CORPORATION
MATERIALS HANDLING EQUIPMENT

NOTICE: THIS DRAWING IN DESIGN AND DETAIL IS THE PROPERTY OF PENTALIFT EQUIPMENT CORPORATION AND IS LOANED SUBJECT TO RETURN ON DEMAND AND UNDER THE EXPRESS CONDITION THAT IT MUST NOT BE COPIED OR USED EXCEPT BY PERMISSION OF PENTALIFT EQUIPMENT CORPORATION.

TITLE	1 Ø 115V AIR POWERED DOCK LEVELER			FOR	
SCALE	N/A	LOT QTY		DRAWN BY	BV
	N/A	DECIMAL TOLERANCES (EXCEPT AS NOTED)	± .005	DATE	5/9/2016
		FRACTION TOLERANCES (EXCEPT AS NOTED)	± 1/32	DRAWING NO.	061-1383
				REV	A

M0922N

Figure 65: Electrical Schematics- Basic Model (Jog Start)

LIST OF ILLUSTRATIONS

Figure 1: Precautionary Labels	2
Figure 2A: Operation Placard	4
Figure 2: Precautionary Labels Continued	3
Figure 3a: Precautionary Label Location - Front Angle	6
Figure 3: Precautionary Label Location	5
Figure 4: Bolt Hole Locations	9
Figure 5: Attach Lifting Devices	9
Figure 6: Hoist Leveler with Chain	11
Figure 7a: Temporary Power Cord & Plug	12
Figure 7b: Power Cord & Junction Box	12
Figure 7c: Lip Chain tied up for shipping	13
Figure 7d: Deck stop chain tied up for shipping	13
Figure 8: Control Panel & Placard Location	14
Figure 11: Dock Leveler Front Shims	14
Figure 12: Dock Leveler Rear Shims	16
Figure 13: Back Angle Weld of Dock Leveler	16
Figure 14: Shim Stacking Method	17
Figure 15: Wedging the Rear Frame Angle to the Rear Pit Curb Angle	16
Figure 19: Rear Shim Location(4" High Rear Shim Shown)	17
Figure 21: Installing Leveler into Pit	18
Figure 22: Rear Shim (4" Shim Kit Shown)	18
Figure 23: 30,000 lb + Outer Rear Shims (4" Shim Kit Channel Shim Shown)	20
Figure 24a: Rear & Roller Shims (4" Shim Kit Shown)	23
Figure 24: Installation Shims (4" Shim Kit Channel Shim Shown)	22
Figure 25: Welding the 3 X 3 Square Tubing to the Curb Angles	24
Figure 26: Welding the 4 X 3 Rectangular Tubing to the Curb Angles	25
Figure 27: Welding the 4 X 3 Rectangular Tubing to the Curb Angles	26
Figure 28: Installing the filler plate	26
Figure 29: Welding the 4 X 3 Rectangular Tubing to the Curb Angles	27
Figure 30: Installing the filler plate	28
Figure 31: Front Angle & Deck Stop Shims	30
Figure 33: Rear Shims	30
Figure 34: Rear Angle Flush with Curb Angle	30
Figure 35: AD Model Curb Angle Force Chart	31
Figure 37: Pour-In Pan Components	33
Figure 38: Foundation cut out and support pad	34
Figure 40: Deck Alignment	36
Figure 41A: Shimming 20" Lips	36
Figure 41: Shimming 16" & 18" Lips	36
Figure 42: Dock Leveler in Position	35

Figure 43: One Inch (1") Gap	35
Figure 44: Conduits Required	37
Figure 45: Conduit Installation Zone	37
Figure 46: Shipping Wire, Bolts, and Lifting Devices.	39
Figure 48: Use Jacking Screw to Eliminate Dead Space	39
Figure 51B: Lifting and supporting the Air Bag Tray	51
Figure 51: Jacking Screw	40
Figure 52: DB13 Installation	43
Figure 53A: Lip Spring Adjustment	58
Figure 53: PLB414AF Installation	43
Figure 54: PLB414AA Installation	44
Figure 55: Minimum 4" Penetration	47
Figure 56: Deck in (Cross Traffic) Stored Position	47
Figure 57: End Loading	48
Figure 58: Below Level End Loads	48
Figure 59: Proper Placement of Maintenance Stand.	49
Figure 60: Lubrication Points	55
Figure 61: Blower Assembly Replacement Parts	61
Figure 62: Replacement Parts	62
Figure 63: Control Panel - Basic Model (Jog Start)	64
Figure 63: Optional Fallsafe Replacement Parts	63
Figure 64: Chains and Spring Components.	60
Figure 65: Electrical Schematics- Basic Model (Jog Start)	65
Figure 66: Chains and Spring connection and routing for Lip Yieldable Mechanism (Shown with Air Bag removed for clarity)	59 6
Figure 67: Adjustable Lip Stop	65

Generic manual for reference only. Contact Pentlift with product serial number to receive owners manual for your specific equipment.

PENTALIFT EQUIPMENT CORPORATION WARRANTY

WARRANTY

Pentalift Equipment Corporation expressly warrants that any product manufactured by **Pentalift Equipment Corporation** will be free from defects in material and workmanship under normal use for a period of one (1) year from the date of shipment of the equipment, provided the original purchaser maintains and operates the product in accordance with proper procedures. In the event the product proves defective in material or workmanship, **Pentalift Equipment Corporation** will at its option:

1. Replace the product or the defective portion thereof without charge to the purchaser; or
2. Alter or repair the product; on site or elsewhere, as **Pentalift Equipment Corporation** may deem advisable, without charge to the purchaser.

The warranty stated in the previous paragraph is that expressed by **PENTALIFT EQUIPMENT CORPORATION** AND IS IN LIEU OF ALL GUARANTEES AND WARRANTIES, EXPRESSED OR IMPLIED BY ANYONE OTHER THAN **PENTALIFT EQUIPMENT CORPORATION**. This warranty does not cover any failure caused by improper installation, misapplication, overloading, abuse, negligence, or failure to lubricate and adjust or maintain the equipment properly and regularly. Parts requiring replacement due to damage resulting from abuse, improper operations, improper or insufficient lubrication, lack of proper protection or vehicle impact are not covered by this warranty. **Pentalift Equipment Corporation** assumes no responsibility or liability for:

1. Consequential damages of any kind which result from use or misuse of the equipment.
2. Damage or failure resulting from the use of unauthorized replacement parts.
3. Damage or failure resulting from modification of the equipment.
4. Damage resulting from the misuse of the equipment.

THERE ARE NO WARRANTIES, EXPRESSED OR IMPLIED, WHICH EXTEND BEYOND THE DESCRIPTION ON THE FACE HEREOF, AND THERE IS NO WARRANTY OF MERCHANTABILITY OR OF FITNESS FOR A PARTICULAR PURPOSE.

Pentalift Equipment Corporation warranties extend only to the original product itself. In no event shall **Pentalift Equipment Corporation** be responsible for or liable to anyone, including third parties, for special, indirect, collateral, punitive, incidental or consequential damages, even if **Pentalift Equipment Corporation** has been advised of the possibility of such damages. Such excluded damages include, but are not limited to, loss of good will, loss of profits, loss of use, interruption of business or other similar indirect financial loss.

Pentalift Equipment Corporation DISCLAIMS all liability arising out of the workmanship, methods and materials used by the installer.

Pentalift Equipment Corporation DISCLAIMS all liability for premature product wear, product failure, property damage or bodily injury arising from improper installation and application.

Pentalift Equipment Corporation will not accept any warranty for which the original purchaser does not notify **Pentalift Equipment Corporation's** Warranty Department of the defect within ninety (90) days after the product defect is discovered. A fully completed Product Registration Card is required prior to the review or processing of any warranty requests or claims.

WARRANTIES, whether expressed or implied, relating to workmanship and materials used in connection with the installation of **Pentalift Equipment Corporation** products are specifically DISCLAIMED.

WR001R02



P.O. Box 1510, Buffalo, NY, U.S.A. 14240-1510
Phone: (519) 763-3625 □ FAX (519) 763-2894
21 Nicholas Beaver Rd, Puslinch, Ontario, N0B 2J0 Canada
Phone: (519) 763-3625 □ FAX (519) 763-2894

NOTE: All Pentalift Equipment Corporation products are subject to design improvement through modification without notice.