



PENTALIFT EQUIPMENT CORPORATION

MECHANICAL DOCK LEVELER OWNERS MANUAL

MODEL NUMBER : _____ **SERIAL NUMBER :** _____

CAPACITY : _____

Individual Model Number(s) and Serial Number(s) must be filled out by the user for future reference.

This manual is an important document.

It shall be kept with the machine or located where readily available to operators and maintenance personnel for reference purposes. Do not install, operate or service this product unless you have read and fully understand the entire contents of this manual. Failure to do so may result in property damage, bodily injury or death. Keep this manual in a safe place for future reference.

NOTE: A very high level of field issues with this type of equipment can be directly attributed to improper or incomplete installation. The installation instructions and information provided for this equipment is thorough. A step by step sequence for installation is provided. All steps must be followed and completed to provide a complete installation. Incomplete or improper installations can lead to equipment malfunction and / or damage, create safety issues and void warranties. Please follow all installation and set ups steps as indicated in the installation instructions and owner's manual. If you are unclear or uncertain regarding any of the steps contact your Pentalift representative for clarification. A copy of the completed steps listing with the sign off and photos of the installation as indicated at the conclusion of the installation instructions will be required prior to any Pentalift factory trouble shooting assistance.

**Pentalift Equipment Corporation
21 Nicholas Beaver Rd
Puslinch, ON N0B 2J0
Phone: 519-763-3625
Fax: 519-763-2894
Parts Phone: 519-763-3625 Extension 625
Ask for Parts Department**

Pentalift Equipment Corporation provides an owners manual when equipment is shipped. Additional manuals are available at \$25.00 each.

IMPORTANT: The owners manuals that are provided on Pentalift Equipment Corporations website are generic in nature. They are provided for general information only. For all purposes, only the owners manual that is specific to the equipment should be referenced and relied on. In order to receive the specific owners manual for specific Pentalift equipment, please contact your Pentalift representative and supply the specific serial number(s) for the equipment the manual is required for. Do not rely on the information in the generic owners manuals provided through the website as it may not be appropriate for your specific Pentalift equipment.

PRODUCT REGISTRATION



PRODUCT REGISTRATION CARD

To validate warranty and to advise of product updates please complete the following information and return to
Pentalift Equipment Corporation

To validate warranty on-line go to: www.pentalift.com

END USER INFORMATION

| | | |
|-------------------------------------|--|-------------------|
| *Company Name: | | |
| Contact *First Name: | *Last Name: | Title: |
| *Mailing Address: | | |
| *City: | *State/Prov. | *Zip/Postal Code: |
| *Phone: () - | Fax: () - | Email: |
| Check Products Purchased: | <input type="checkbox"/> Levelers, <input type="checkbox"/> Vehicle Restraints, <input type="checkbox"/> Seals/Shelters, <input type="checkbox"/> Elevating Docks, <input type="checkbox"/> Lift Tables | |
| *Serial Number(s): | Invoice # (if available): | |
| Dealer Name: | Sales Rep.: | |
| Manual Verification *Manual Number: | | |

Please return to:

Pentalift Equipment Corporation
P.O. Box 1510,
Buffalo, NY 14240-1510

or

Pentalift Equipment Corporation
21 Nicholas Beaver Rd
Puslinch, Ontario
N0B 2J0

Attention: Service Department

Or Fax to (519) 763-2894

SAFETY INFORMATION AND WARNINGS



READ THESE SAFETY PRACTICES BEFORE INSTALLING, OPERATING OR SERVICING THE DOCK LEVELER. FAILURE TO FOLLOW THESE SAFETY PRACTICES MAY RESULT IN PROPERTY DAMAGE, BODILY INJURY OR DEATH.

THE OPERATION OF THIS EQUIPMENT IS SUBJECT TO CERTAIN HAZARDS THAT CAN BE PROTECTED AGAINST ONLY BY THE EXERCISE OF CARE AND COMMON SENSE AND NOT BY MECHANICAL MEANS. IT IS, THEREFORE, ESSENTIAL TO HAVE COMPETENT, QUALIFIED OPERATORS TRAINED IN THE SAFE OPERATION AND CARE OF THIS TYPE OF EQUIPMENT. ALL PERSONNEL MUST COMPLETELY UNDERSTAND THIS SAFETY INFORMATION BEFORE WORKING ON OR NEAR THIS EQUIPMENT.



DANGER indicates an imminently hazardous situation which, if not avoided, will result in death or serious injury.



WARNING indicates a potentially hazardous situation which, if not avoided, could result in death or serious injury.



CAUTION, used with the safety alert symbol, indicates a potentially hazardous situation which, if not avoided, could result in minor or moderate injury.



NOTICE is used to address practices not related to personal injury.



BEFORE DOING ANY INSTALLATION, MAINTENANCE, INSPECTION OR TROUBLE SHOOTING, BARRICADE ALL AREAS FROM TRAFFIC AROUND THE WORK AREA INSIDE (AND OUTSIDE IF APPLICABLE) FOR SAFETY AND POST APPROPRIATE

WARNING SIGNS. NEVER GO BENEATH THE DOCK LEVELER FOR ANY REASON UNLESS THE LIP AND DECK ARE PROPERLY SUPPORTED BY THE MAINTENANCE STAND (SEE “SUPPORTING THE LEVELER FOR MAINTENANCE” on page 40). IT IS THE RESPONSIBILITY OF THE OWNER TO ENSURE THAT NO LOAD OR TRAFFIC IS PLACED ON THE DECK WHILE THE MAINTENANCE STAND IS IN USE. THE CONSTRUCTION OF THE MAINTENANCE STAND IS INTENDED TO SUPPORT THE WEIGHT OF THE UNLOADED DOCK LEVELER ONLY.



ALWAYS ENSURE NO ONE IS WITHIN 6 FEET OF THE FRONT (LIP END) OF THE DOCK LEVELER PRIOR TO ACTIVATION. THE HINGED LIP WILL EXTEND RAPIDLY AND LOCK INTO ITS WORKING POSITION DURING UPWARD MOVEMENT OF THE DECK. STAY CLEAR OF DOCK LEVELER WHEN IT IS MOVING.



DOCK LEVELER CAPACITY: THE RATED CAPACITY OF THE DOCK LEVELER AS STATED ON THE SERIAL NUMBER PLATE IS A STATIC RATING. NUMEROUS DYNAMIC LOADING FACTORS RESULT IN THE GROSS LOAD CAPACITY (ROLLOVER CAPACITY) BEING SIGNIFICANTLY LESS THAN THE RATED STATIC CAPACITY OF THE DOCK LEVELER. FACTORS WHICH AFFECT THE ROLL OVER CAPACITY ARE: WEIGHT OF THE LOAD; WEIGHT OF THE FORK TRUCK; SPEED OF THE FORK TRUCK AS IT ROLLS OVER THE DOCK LEVELER; INCLINE OR DECLINE SLOPE OF THE DOCK LEVELER DECK AND LIP WHEN IN USE; FREQUENCY OF USE AND DESIRED LIFE OF THE DOCK LEVELER. PRIOR TO USING THE DOCK LEVELER, OR IF THE APPLICATION CONDITIONS FOR THE DOCK LEVELER CHANGE IN ANY RESPECT, CONTACT YOUR AUTHORIZED PENTALIFT REPRESENTATIVE TO CONFIRM THE SPECIFIC DOCK LEVELER’S SUITABILITY FOR THE APPLICATION.



NEVER WALK ON THE LIP TO LOWER THE DOCK LEVELER ONTO A TRUCK BED. (SEE “Figure 44: Walk Down the Deck” on page 35)



TO AVOID POSSIBLE PERSONNEL INJURY AS WELL AS, TO AVOID DAMAGE TO THE DOCK LEVELER AND/OR THE PRODUCT, DO NOT DRAG OR SLIDE ANYTHING ACROSS THE SURFACE OF THE DOCK LEVELER. ALWAYS ENSURE THE FORKLIFT FORKS ARE RAISED TO CLEAR THE DOCK LEVELER SURFACE AND THE DOCK LEVELER COMPONENTS.



THE RATCHET HOLD DOWN CONTAINS A COMPRESSED SPRING WHICH WILL EJECT FROM THE TUBE IF OPENED AND COULD CAUSE SERIOUS INJURY OR DEATH. DO NOT TRY TO OPEN, TAKE APART OR TAMPER WITH THE TUBE. IF THIS PART IS DAMAGED, REMOVE AND REPLACE.

1. When not in use, the dock leveler must be in the stored (cross traffic) position, with the lip inside the front angle. (See “Figure 43: Deck in Stored Position” on page 34)
2. Before loading/unloading the truck, assure the trailer is in position firmly against both of the dock bumpers and **ENGAGE A VEHICLE RESTRAINT or CHOCK THE TRUCK WHEELS** to eliminate the possibility of the truck rolling or inching forward.
3. Return dock leveler to the stored position before allowing truck to depart.
4. Be certain no equipment, material or personnel are on the dock leveler before allowing truck to depart.
5. Regular inspection and maintenance must be performed to keep the equipment in proper operating condition in accordance with the detailed instructions in this manual.
6. Anyone using or in the vicinity of this equipment must wear protective footwear with steel toes.
7. The deck surface must be kept clean and free from oil, debris, etc. Keep debris, etc. from underneath the unit.
8. Never use anything other than the operator’s weight to lower the deck from its raised position.
9. Never stand between the dock and a truck.
10. Stay clear of operating path at all times.
11. Do not operate, use, maintain or install this equipment if you are impaired in any manner.
12. Assure that the equipment is not used by anyone if you believe that any part of it might be in disrepair (e.g. bent structural members, broken welds, etc.). See “INSTALLATION, INSPECTION, MAINTENANCE AND LUBRICATION” on page 45.
13. If you have any questions, contact your immediate supervisor or your authorized Pentalift representative for assistance.

OWNER RESPONSIBILITY

The Owner's Responsibilities include the following:

1. The owner shall recognize the inherent danger of the interface between dock and transport vehicle. The Owner shall, therefore, train and instruct operators in the safe use of dock leveling devices.
 2. When a transport vehicle is positioned as closely as practicable to a dock leveling device, there shall be at least 4" (100 mm) of overlap between the front edge of the lip and the edge of the floor or sill of the transport vehicle.
 3. Nameplates, cautions, instructions and posted warnings shall not be obscured from the view of operating or maintenance personnel for whom such warnings are intended.
 4. Manufacturer's recommended periodic maintenance and inspection procedures in effect at date of shipment shall be followed, and written records of performance of these procedures shall be kept.
 5. Dock leveling devices that are structurally damaged or have experienced a sudden loss of support while under load, such as might occur when a transport vehicle is pulled out from under the dock leveling device, shall be removed from service, inspected by **Pentalift Equipment Corporation's** authorized representative and repaired as needed before being placed back in service. The owner shall receive written authorization from **Pentalift Equipment Corporation** through the authorized Pentalift representative that they can continue to use the dock leveler.
 6. **Pentalift Equipment Corporation** shall supply replacement nameplates, caution or instruction labels and operating and maintenance manuals upon request of the owner. The owner shall see that all nameplates and caution and instruction markings or labels are in place and legible and that the appropriate operating and maintenance manuals are provided to users.
 7. Modifications or alterations of dock leveling devices shall be made only with written permission of **Pentalift Equipment Corporation**. Alteration permission must be signed by both the Pentalift Post Sale Customer Service Manager and the President to be valid.
 8. When industrial trucks are driven on and off transport vehicles during the loading and unloading operation, the brakes on the transport vehicle shall be applied and wheel chocks or positive restraints that provide the equivalent protection of wheel chocks engaged.
- NOTE:** It is recognized that these devices are intended to secure a transport vehicle to a loading dock by mechanical means. However, no standards currently exist for the strength, construction or attachment of the underride guard on a transport vehicle. It is therefore recommended that users of such positive restraint devices review:
- The means of attachment to the transport vehicle
 - The strength of the overall connection
 - The proper coordination of the actuation of devices with any signalling system used
 - The need to use wheel chocks
9. In selecting dock leveling devices, it is important to consider not only present requirements, but also future plans or adverse environments.



Unless specifically agreed to in writing by Pentalift Equipment Corporation at the time the equipment is ordered and prior to the equipment's manufacture, this equipment is sold as a complete package. It is not to be altered, changed or added to in any way or form, in its configuration and function, without the written permission of Pentalift Equipment Corporation.

TABLE OF CONTENTS

| | |
|---|----|
| PRODUCT REGISTRATION | I |
| SAFETY INFORMATION AND WARNINGS..... | II |
| OWNER RESPONSIBILITY | IV |
| TABLE OF CONTENTS | 1 |
| PRECAUTIONARY LABELING | 2 |
| INSTALLATION INSTRUCTIONS FOR PIT MODEL MECHANICAL DOCK LEVELERS | 5 |
| PREPARATION PRIOR TO INSTALLATION | 5 |
| INSTALLATION INTO PIT..... | 6 |
| WELDING REFERENCE INFORMATION | 8 |
| WELDING REFERENCE CHARTS..... | 8 |
| INSTALLATION INTO PIT USING SHIM KIT | 12 |
| INSTALLATION USING FILLER PLATE..... | 15 |
| INSTALLATION INSTRUCTIONS FOR 3-INCH FILLER PLATE | 15 |
| INSTALLATION INSTRUCTIONS FOR 4-INCH FILLER PLATE | 16 |
| FILLER PLATE INSTALLATION INSTRUCTIONS (WITH TWO TUBES & TWO SUPPORT BARS)..... | 17 |
| FILLER PLATE INSTALLATION INSTRUCTIONS (WITH TWO TUBES & FOUR SUPPORT BARS)..... | 18 |
| INSTALLATION PICTURES | 20 |
| INSTALLATION INSTRUCTIONS | 22 |
| POUR-IN DOCK LEVELERS | 22 |
| PREPARATION PRIOR TO INSTALLATION | 22 |
| INSTALLATION PICTURES | 27 |
| Bumper Installation Guide lines | 28 |
| Locating Dock Bumpers during installation: | 28 |
| Installation methods I.E. Lagging and or welding: | 28 |
| BREAK-IN AND PERFORMANCE CHECK | 31 |
| OPERATING INSTRUCTIONS..... | 33 |
| HYDRAULIC CONVERSION KIT -FOR CURRENT MECHANICAL DOCK LEVELER OWNER | 36 |
| END LOADING/ UNLOADING INSTRUCTIONS | 39 |
| END LOADING BELOW LEVEL CONTROL OPERATION..... | 39 |
| SUPPORTING THE LEVELER FOR MAINTENANCE..... | 40 |
| MAINTENANCE AND LUBRICATION | 44 |
| NORMAL SEQUENCES OF STEPS TO ADJUST MECHANICAL DOCK LEVELER THAT IS NOT PROPERLY FUNCTIONING | 50 |
| ADJUSTMENTS | 50 |
| LIP ASSIST SPRING ADJUSTMENT | 51 |
| adjustments TO LIP AND LIFT SPRINGS RELATIVE TO RATCHET HOLD DOWN..... | 54 |
| MAIN LIFT SPRING ADJUSTMENT | 54 |
| LIP YIELD MECHANISM..... | 55 |
| TROUBLE SHOOTING GUIDE | 57 |
| REPLACEMENT PARTS | 59 |
| DOCK LEVELER REPLACEMENT PARTS | 60 |
| OPTIONAL FALLSAFE REPLACEMENT PARTS | 61 |
| LIST OF ILLUSTRATIONS | 62 |
| PENTALIFT EQUIPMENT CORPORATION WARRANTY..... | 64 |

PRECAUTIONARY LABELING

① 250-1127
QTY: 2 PER UNIT

LIFT 1 DOCK ONLY (WITH NO LOAD ON IT)

FORKS HERE

↓

DO NOT REMOVE THIS LABEL. 250-1127

② 250-1140
QTY: 1 PER UNIT

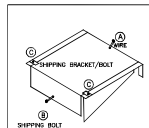

CAUTION

REMOVE WIRE A FROM RELEASE CHAIN AND LET CHAIN FALL BACK IN BEFORE REMOVING BOLT B OR REMOVING BRACKET/BOLT C

250-1140

③ 250-2058
QTY: 1 PER UNIT

DANGER / IMPORTANT

READ AND UNDERSTAND THE INSTALLATION INSTRUCTIONS AND OWNERS MANUAL IN THEIR ENTIRETY BEFORE COMPLETING CONCRETE WORK, INSTALLING AND/OR USING EQUIPMENT; FAILURE TO COMPLY MAY RESULT IN DEATH OR PERSONAL INJURY.

⑤ 250-1817
QTY: 1 PER UNIT

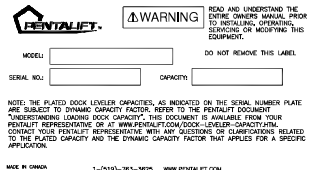

WARNING

READ AND UNDERSTAND THE ENTIRE OWNER MANUAL PRIOR TO INSTALLING, OPERATING, SERVICING OR MODIFYING THIS EQUIPMENT.

DO NOT REMOVE THIS LABEL.

MODEL: _____

SERIAL NO.: _____ CAPACITY: _____

NOTE: THE PLATED DOCK LEVELER CAPACITIES, AS INDICATED ON THE SERIAL NUMBER PLATE ARE SUBJECT TO DYNAMIC CAPACITY FACTOR. REFER TO THE PENTALIFT DOCUMENT "UNDERSTANDING LOADING DOCK CAPACITY" THIS DOCUMENT IS AVAILABLE FROM YOUR PENTALIFT REPRESENTATIVE OR AT WWW.PENTALIFT.COM/DOCK-LEVELER-CAPACITY. CONTACT YOUR PENTALIFT REPRESENTATIVE WITH ANY QUESTIONS OR CLARIFICATIONS RELATED TO THE PLATED CAPACITY AND THE DYNAMIC CAPACITY FACTOR THAT APPLIES FOR A SPECIFIC APPLICATION.

MADE IN CHINA 1-(219)-763-8825 WWW.PENTALIFT.COM 250-1817

⑥ 250-1143
QTY: 1 PER UNIT



⑬ 250-7090
QTY: 1 PER UNIT NEXT TO SERIAL NUMBER PLATE
QTY: 1 PER UNIT AFFIXED TO PLACARD

OWNER'S MANUAL



M083R22 250-7090

⑨ 250-1882
QTY: 2 PER UNIT

WARNING

TO AVOID PERSONAL INJURY READ OWNERS MANUAL BEFORE OPERATING

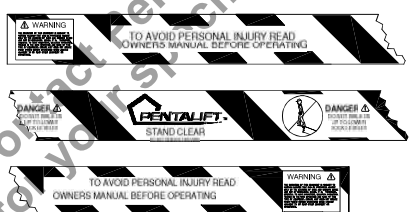

250-2467 ⑧
QTY: 1 PER UNIT

THIS SIDE OUT

DO NOT REMOVE THIS LABEL.

⑩ 250-2320
QTY: 2 PER UNIT

DANGER

Unsupported dock leveler ramps can lower unexpectedly.

Before allowing vehicle to leave the dock, always:

- Ensure that no equipment, material or people are on the dock leveler.
- Return the dock leveler to its stored position on dock level.

Failure to follow posted instructions could result in death or serious injury. DO NOT REMOVE THIS LABEL.

⑪ 250-1148
QTY: 1 PER UNIT

SAFETY INFORMATION

OPERATION

- Read and follow all instructions and warnings in the Owner's Manual.
- Use of dock leveler restricted to properly trained operators.
- Always ensure that truck trailer is properly supported from separate lifting device (dock leveler or hoist) to load or unload.
- Before extending dock leveler:
 - Ensure trailer is blocked in against bumpers.
 - Remove any load blocks if required.
 - Dock leveler is correct to avoid for interference. If it is does not lower to higher level, reposition vehicle.
 - Ensure that truck bed supports extended to or the leveler frame supports the ramp before driving on ramp.
- Clear of kingpins and front and sides of moving dock leveler.
- Never use damaged or malfunctioning dock leveler. Report problems immediately to supervisor.

MAINTENANCE/SERVICE

- Read and follow all instructions, warnings and maintenance schedules in the owner's manual.
- Maintenance/Service of dock leveler restricted to properly trained personnel.
- Place barriers on driveway and or dock floor to indicate service work is being performed.
- DO NOT OPERATE unless dock leveler is safely supported by maintenance stand.
- If electrically powered, turn off and use OSHA locked/tagged procedures.

INSPECTION

DATE _____

INSPECTED BY _____

⑫ 250-2495
QTY: 1 PER UNIT

DANGER

CRUSH HAZARD

DO NOT ENTER PIT unless dock leveler is safely supported by maintenance stand. Place barriers on drive way and dock floor to indicate service work being performed. Do not remove main springs until leveler is safely supported by maintenance stand. Main springs contain stored energy. Be sure springs are fully unloaded and ends are loose before removal. Failure to comply will result in death or serious injury. Refer to owner's manual for proper maintenance procedures.

DO NOT REMOVE THIS LABEL. PENTALIFT EQUIPMENT CORPORATION

⑦ 250-4969
QTY: 1 PER UNIT

WARNING

THIS PART CONTAINS A COMPRESSED SPRING WHICH WILL EJECT FROM THE TUBE IF OPENED AND COULD CAUSE SERIOUS INJURY OR DEATH. DO NOT TRY TO OPEN, TAKE APART, OR TAMPER WITH THIS TUBE. IF THIS PART IS DAMAGED, REMOVE AND REPLACE.

M083AAA4

Figure 1: Precautionary Labels

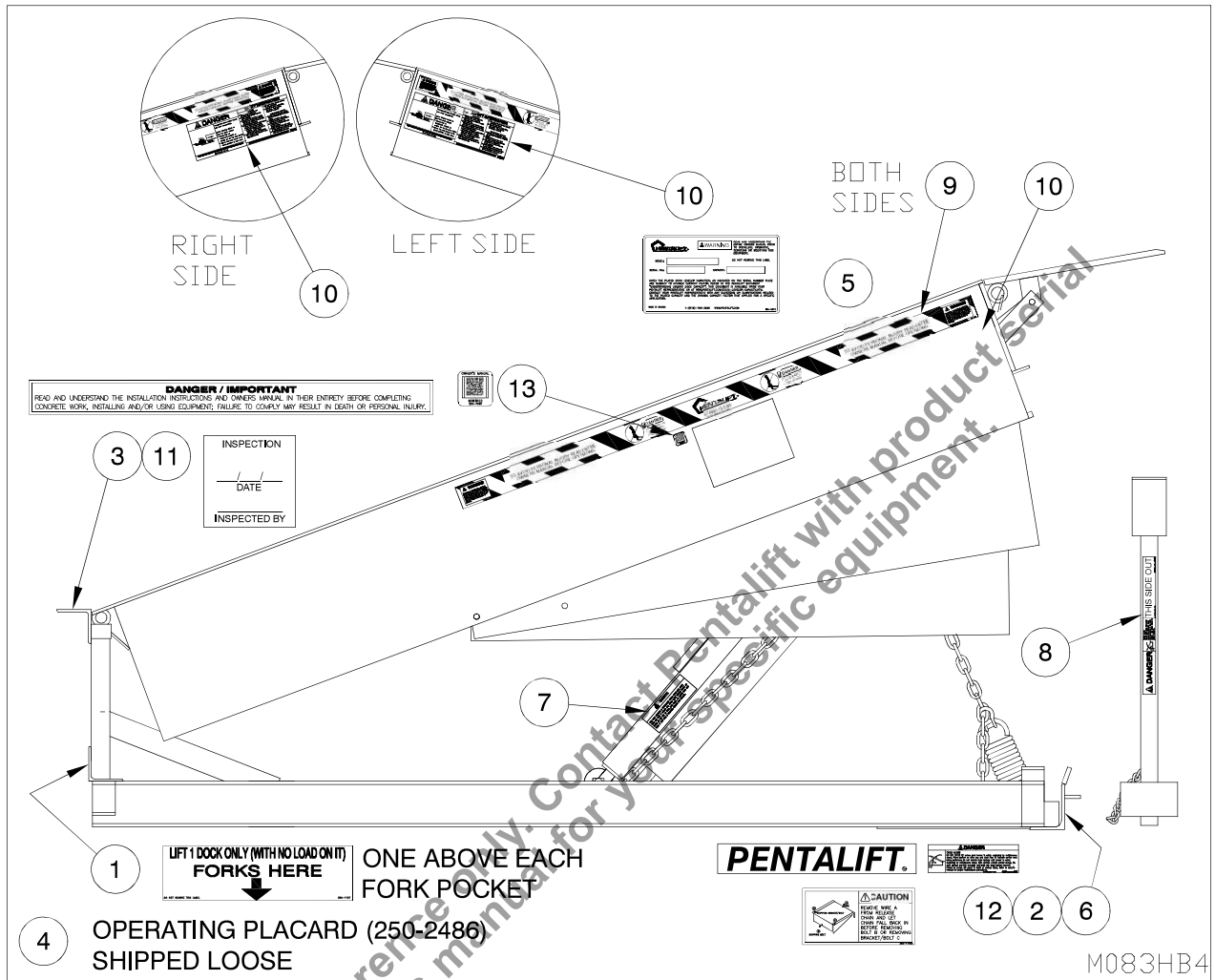

Figure 2: Precautionary Label Locations

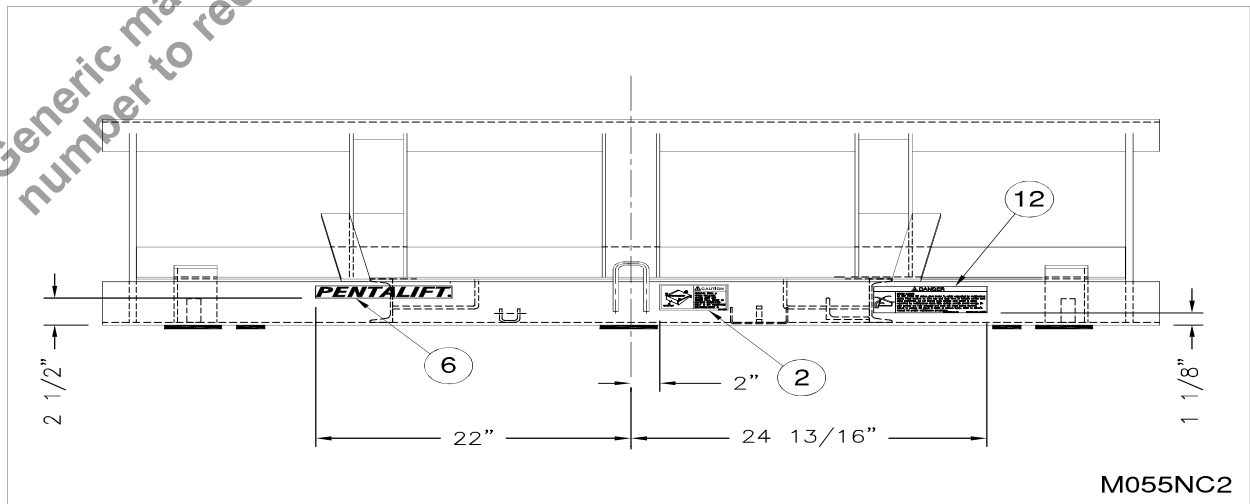

Figure 2a: Precautionary Label Locations - Front Angle

Be sure that all labeling is in place and intact when the unit is received. If any of the precautionary labels are missing or illegible, contact your Pentalift representative for immediate replacement.

NOTE: In some instances, product configuration and / or product options may dictate that the product labels will not be placed as indicated on the drawing (“Figure 2: Precautionary Label Locations” on page 3). Different label locations will be selected at the factory, when required, to avoid an impaired view of the labels. Note the label locations as supplied on the product, when it is received to accommodate future label replacement requirements.

NOTE: It is the owner’s responsibility to assure that all precautionary labeling remains legible and in its original position throughout the life of the product. It is also the owner’s responsibility to ensure that all labels are and will continue to be readily visible to the operators and people working with and around the equipment. If the visibility of any label is compromised for any reason then: either 1) Rectify the situation to allow the label to be readily visible 2) Order replacement label(s) from Pentalift for installation in a location that does facilitate complete visibility. If any of the precautionary labels are missing or illegible, contact your Pentalift representative for immediate replacement. Inspection shall be done during regular maintenance and lubrication (See “MAINTENANCE AND LUBRICATION” on page 45).

To re-order precautionary labels , use the following part numbers:

| | ITEM NO. | PART NO. | QTY/UNIT | DESCRIPTION |
|----------------------|----------|----------|----------|---------------------------------------|
| Precautionary Labels | 3 | 250-2058 | 1 | “IMPORTANT Read the installation...” |
| | 5 | 250-1817 | 1 | Specification Plate |
| | 6 | 250-1143 | 1 | “PENTALIFT” |
| | 7 | 250-4969 | 1 | “CONTAINS A COMPRESSED SPRING |
| | 8 | 250-2467 | 1 | “THIS SIDE OUT” |
| | 9 | 250-1882 | 2 | SAFETY STRIPE |
| | 10 | 250-2320 | 2 | “DANGER Unsupported Dock...” |
| | 11 | 250-1148 | 1 | Inspection Sticker |
| | 12 | 250-2495 | 1 | “DO NOT ENTER PIT...” |
| | 13 | 250-7090 | 1 | “DECAL;BARCODE;MD” |
| Installation | 1 | 250-1127 | 2 | Forks Here |
| | 2 | 250-1140 | 1 | “CAUTION Remove wire...” |
| | 4 | 250-2486 | 1 | Operating Instructions (Wall Mounted) |
| | 13 | 250-7090 | 1 | “DECAL;BARCODE;MD” (add to placard) |

NOTE: State Model # and Serial # when ordering replacement parts.

INSTALLATION INSTRUCTIONS FOR PIT MODEL MECHANICAL DOCK LEVELERS

⚠ DANGER

- WIRING MUST BE DONE BY A QUALIFIED ELECTRICIAN.
- ALWAYS USE APPROPRIATE LOCK-OUT PROCEDURES DURING ANY ELECTRICAL INSTALLATIONS.
- ENSURE SUPPLY VOLTAGE IS CORRECT.
- ON 3 PHASE UNITS ASSURE PHASE POLARITY IS CORRECT.
- ALWAYS OBSERVE ALL APPLICABLE ELECTRICAL CODES.

NOTE: A very high level of field issues with this type of equipment can be directly attributed to improper or incomplete installation. The installation instructions and information provided for this equipment is thorough. A step by step sequence for installation is provided. All steps must be followed and completed to provide a complete installation. Incomplete or improper installations can lead to equipment malfunction and / or damage, create safety issues and void warranties. Please follow all installation and set ups steps as indicated in the installation instructions and owner's manual. If you are unclear or uncertain regarding any of the steps contact your Pentlift representative for clarification. A copy of the completed steps listing with the sign off and photos of the installation as indicated at the conclusion of the installation instructions will be required prior to any Pentlift factory trouble shooting assistance.

IMPORTANT

PREPARATION PRIOR TO INSTALLATION

NOTE: Perform installation instructions in the same sequence as they are listed below. To accommodate a complete installation there is a blank space provided beside each numbered step in the installation instructions. Please check off the steps sequentially as they are completed. This will assist in confirming a complete installation.

⚠ DANGER

Before doing any installation, maintenance, inspection or trouble shooting, barricade all areas from traffic around the work area inside (and outside if applicable) for safety and post appropriate warning signs.

⚠ DANGER

NEVER GO BENEATH THE DOCK LEVELER FOR ANY REASON UNLESS THE DECK AND LIP ARE PROPERLY SUPPORTED BY THE MAINTENANCE STAND (SEE "SUPPORTING THE LEVELER FOR MAINTENANCE" on page 40) IT IS THE RESPONSIBILITY OF THE OWNER TO ENSURE THAT NO LOAD OR TRAFFIC IS PLACED ON THE DECK WHILE THE MAINTENANCE STAND IS IN USE. THE CONSTRUCTION OF THE MAINTENANCE STAND IS INTENDED TO SUPPORT THE WEIGHT OF THE UNLOADED DOCK LEVELER ONLY.

⚠ DANGER

MAKE SURE LIFTING AND SLINGING DEVICES ARE OF SUFFICIENT CAPACITY, USED IN THE CORRECT MANNER AND ARE IN GOOD WORKING ORDER. ALL LIFTING, POSITIONING AND INSTALLATION, AS WELL AS THE BREAK-IN AND PERFORMANCE CHECK MUST BE DONE BY QUALIFIED PERSONNEL TRAINED AND EXPERIENCED IN NECESSARY SAFETY PROCEDURES.

⚠ DANGER

INADEQUATE LIFTING EQUIPMENT OR PRACTICES CAN CAUSE A LIFTED LOAD TO FALL UNEXPECTEDLY. MAKE SURE THAT EYE BOLTS AND LIFTING CHAIN OR OTHER LIFTING DEVICES ARE IN GOOD CONDITION AND HAVE A RATED CAPACITY OF AT LEAST 3500 LBS FOR THE LIFTING ANGLE USED. CONFIRM THE SHIPPING WEIGHT OF THE DOCK LEVELER. IF IT IS GREATER THAN 3500 LBS THEN INCREASE THE RATED CAPACITY OF THE LIFTING DEVICE(S) TO ACCOMMODATE THE SHIPPING WEIGHT OF THE DOCK LEVELER WHEN IT IS BEING LIFTED OR PLACED INTO THE PIT. STAND CLEAR OF THE DOCK LEVELER WHEN IT IS BEING PLACED INTO THE PIT. FAILURE TO FOLLOW THIS WARNING CAN ALLOW THE DOCK LEVELER TO HIT SOMEONE, CAUSING SERIOUS INJURY OR DEATH.

1. ___ Assure pit conforms to appropriate Pentlift pit drawing.
2. ___ Confirm pit curb angle is properly installed and meets the force requirements as shown in “Figure 13: Curb Angle Force Chart” on page 11.
3. ___ Clean pit of all debris.
4. ___ For units with a nominal depth of 20” being installed into a deeper pit, proceed to the “INSTALLATION INTO PIT USING SHIM KIT” on page 12.

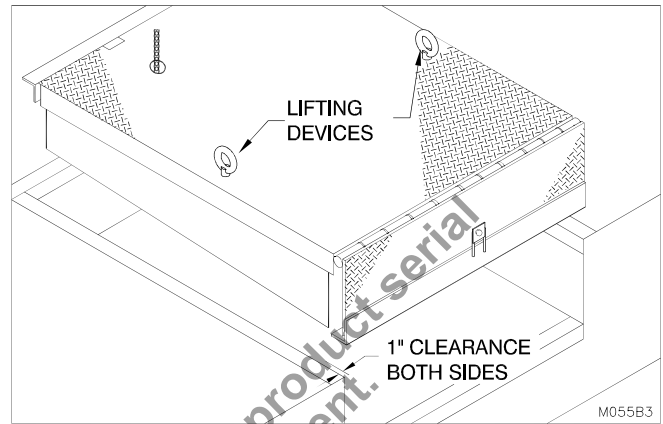

Figure 3: Hoist Using Lifting Devices

INSTALLATION INTO PIT

5. ___ Hoist leveler into pit. (See “Figure 3: Hoist Using Lifting Devices” on page 6) Position the leveler into the pit opening.
6. ___ **⚠ DANGER** MAKE SURE LIFTING AND SLINGING DEVICES ARE OF SUFFICIENT CAPACITY, USED IN THE CORRECT MANNER AND ARE IN GOOD WORKING ORDER. ALL LIFTING, POSITIONING AND INSTALLATION, AS WELL AS THE BREAK-IN AND PERFORMANCE CHECK MUST BE DONE BY QUALIFIED PERSONNEL TRAINED AND EXPERIENCED IN NECESSARY SAFETY PROCEDURES.
7. ___ **⚠ DANGER** INADEQUATE LIFTING EQUIPMENT OR PRACTICES CAN CAUSE A LIFTED LOAD TO FALL UNEXPECTEDLY. MAKE SURE THAT EYE BOLTS AND LIFTING CHAIN OR OTHER LIFTING DEVICES ARE IN GOOD CONDITION AND HAVE A RATED CAPACITY OF AT LEAST 3500 LBS FOR THE LIFTING ANGLE USED. CONFIRM THE SHIPPING WEIGHT OF THE DOCK LEVELER. IF IT IS GREATER THAN 3500 LBS THEN INCREASE THE RATED CAPACITY OF THE LIFTING DEVICE(S) TO ACCOMMODATE THE SHIPPING WEIGHT OF THE DOCK LEVELER WHEN IT IS BEING LIFTED OR PLACED INTO THE PIT. STAND CLEAR OF THE DOCK LEVELER WHEN IT IS BEING PLACED INTO THE PIT. FAILURE TO FOLLOW THIS WARNING CAN ALLOW THE DOCK LEVELER TO HIT SOMEONE, CAUSING SERIOUS INJURY OR DEATH.
8. ___ Assure that 1” clearance is maintained between the side of the leveler platform and the side pit wall and that the rear angle of the dock leveler is firmly against the rear curb angle.
9. ___ Remove the top shipping bolts and lifting devices. Some units come equipped with a front U-Bracket while others come equipped with a front Half Moon Bracket. If your unit comes with the front U-Bracket then **remove** the front shipping bolt then **remove** the U-bracket and clean up the remaining weld to ensure there is no interference with the lip operation. If your unit comes with the Half Moon Bracket, first **remove** the front shipping bolt and finally **remove** the Half Moon Bracket and clean up the remaining weld to ensure there is no interference with the lip operation. (See “Figure 4: Shipping Wire, Bolts and Lifting Devices” on page 7)
10. ___ Operate the dock leveler by pulling the release chain to its full extension and HOLDING until the deck’s upward movement stops; then let go of the chain and let it fall back into the pocket.



ALWAYS ENSURE NO ONE IS WITHIN 6 FEET OF THE FRONT (LIP END) OF THE DOCK LEVELER PRIOR TO ACTIVATION. THE HINGED LIP WILL EXTEND RAPIDLY AND LOCK INTO ITS WORKING POSITION DURING UPWARD MOVEMENT OF THE DECK. STAY CLEAR OF DOCK LEVELER WHEN IT IS MOVING.

11. ___ Support the dock leveler in accordance with instructions in the "SUPPORTING THE LEVELER FOR MAINTENANCE" on page 40.
12. ___ For units with full range toe guards, support the lower half of the toe guard and remove the self tapping screw which holds it in the shipping position. (See "Figure 4: Shipping Wire, Bolts and Lifting Devices" on page 7) Carefully lower the toe guard and avoid pinch points.
13. ___ Place shims of minimum length and width of 3" by 4" and a minimum thickness of 14 gauge under rear frame until top rear of dock leveler is flush with rear curb angle. (See "Figure 6: Shim Rear Frame" on page 7 for shim placement) Tack weld into position.

NOTE: Shims must be positioned to support the entire base of deck stops, fallsafe supports, and rear frame members.

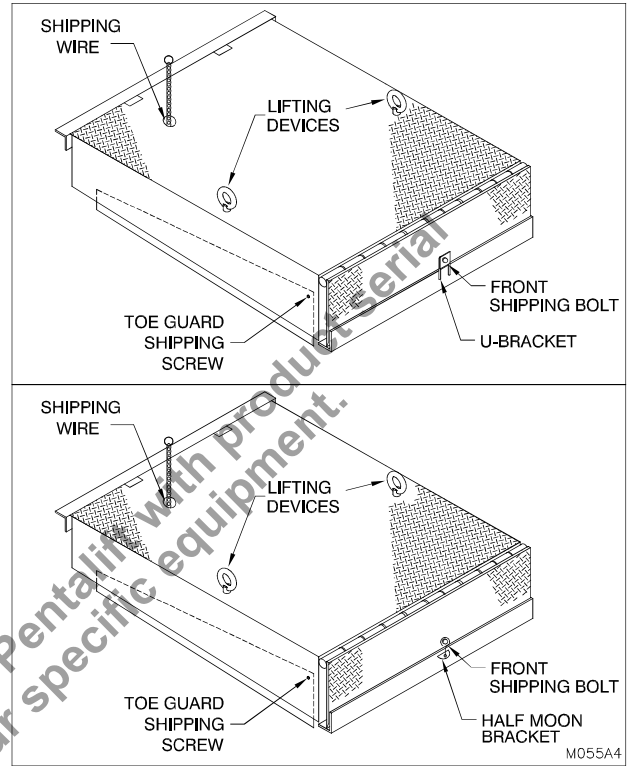

Figure 4: Shipping Wire, Bolts and Lifting Devices

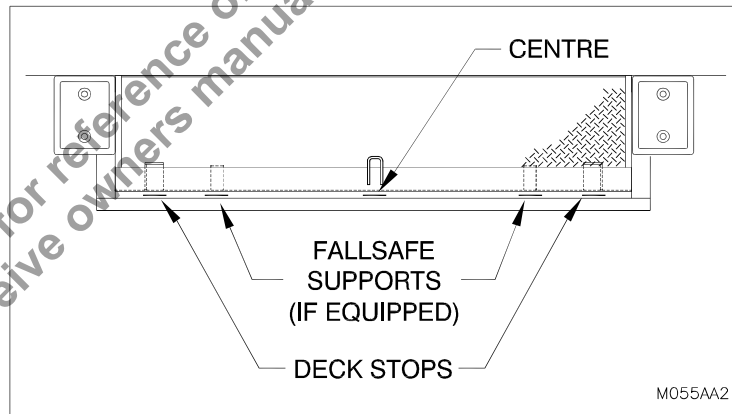

Figure 5: Shim Front Frame

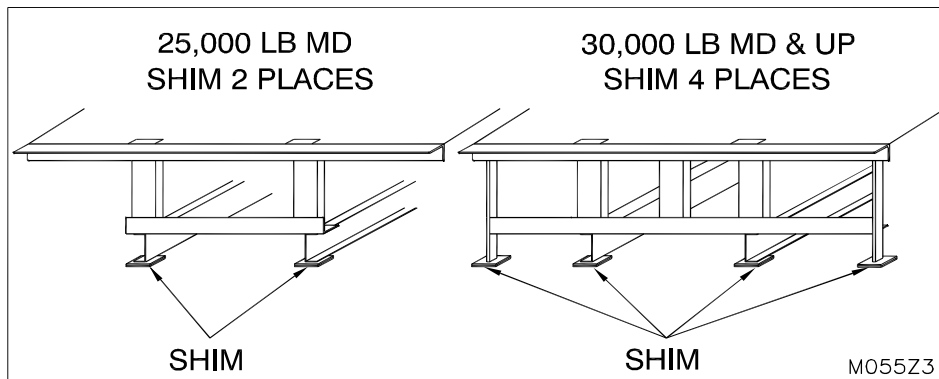

Figure 6: Shim Rear Frame

WELDING REFERENCE INFORMATION

- Observe and obey all welding safety requirements per AWS D1.1-92. (W117.2-74 in Canada.)
- Welding electrodes are to be clean and free from moisture.
- Material to be welded must be clean and free of oils, excessive millscale/rust etc.
- All craters are to be filled to a minimum of 85% of the cross sectional area of the weld.
- All under cutting is to be removed by either welding, grinding or a combination of both.
- Maximum reinforcement on butt welds is 1/8".
- Use highest current possible per chart below to obtain satisfactory weld.

WELDING REFERENCE CHARTS

| Rated Capacity | "A" Dimension, Figure 12, page 7 |
|--|-------------------------------------|
| 25,000 lb 30,000 lb 35,000 lb 40,000 lb | 3" |
| 45,000 lb 50,000 lb | 6" |

| Electrode | E7018 | |
|-----------|---------|---------|
| Diameter | 1/8" | 5/32" |
| Amperage | 130-150 | 140-180 |

14. ___ Lower the dock leveler to the stored position and shim the front frame under the two deck stops and in the center of the dock leveler until the deck plate is flush with the top of the front curb angle and the floor. For units equipped with Mechanical Fallsafe, also shim beneath the fallsafe supports. (See "Figure 5: Shim Front Frame" on page 7 for shim placement.)

Note: Mechanical dock levelers do cant side to side. This is normal. Do not unevenly shim the front frame angle to accommodate.

15. ___ Confirm that the back angle of dock leveler is firmly against and flush with the top of the rear curb angle and that the dock leveler has remained square in the pit before continuing.

16. ___ Make sure the rear pit curb angle is straight and level prior to installation. Make sure the dock leveler rear frame angle (or flat bar) is straight to match the rear pit curb angle. If the rear frame angle (or flat bar) is not straight then force the angle back to match the straight rear pit curb angle using a wedging device between the frame angle and the back of the deck as shown in "Figure 7: Wedging the Rear Frame Angle to the Rear Pit Curb Angle" on page 8. Tack weld the straightened angle to the rear pit curb angle. Repeat the wedging process as required over the length for the rear frame angle.

17. ___ Weld back angle of dock leveler to rear curb angle as shown in "Figure 8: Weld to Rear Curb Angle" on page 8 using the Welding Reference Information and Welding Reference Charts as a guide.

18. ___ Raise the dock leveler and support the deck and lip from closing. (See "SUPPORTING THE LEVELER FOR MAINTENANCE" on page 40)

19. ___ Weld front shim stacks securely to front curb angle (3" long weld) and to front frame of dock leveler. (See "Figure 9: Weld to Front Curb Angle" on page 9) Tack rear side of shims as well.

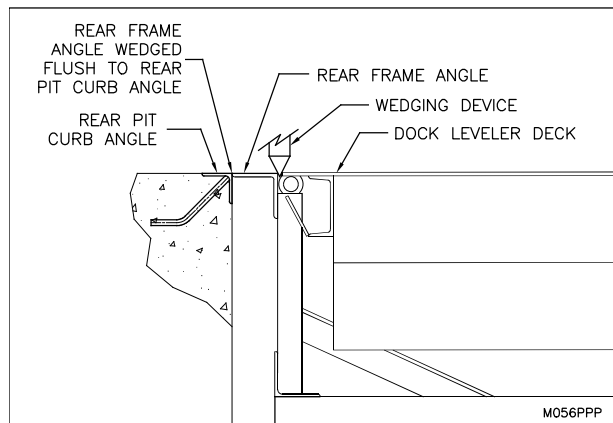

Figure 7: Wedging the Rear Frame Angle to the Rear Pit Curb Angle

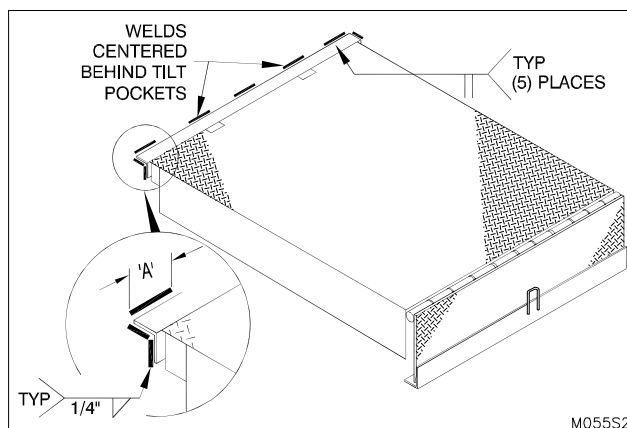

Figure 8: Weld to Rear Curb Angle

20. ___ Weld the rear shim stacks to the frame of the dock leveler. (See “Figure 6: Shim Rear Frame” on page 7)
21. ___ Place shims of minimum length and width of 3” by 4” and a minimum thickness of 14 gauge directly under lifting arm bracket. (See “Figure 10: Shim Beneath Lifting Arm Bracket” on page 9) Weld shim stacks to dock leveler frame.

NOTE: All shim stacks must be welded together.

22. ___ Once the leveler has been fully installed, remove the top flange of the lifting angle. (See “Figure 11: Top Flange Removal Diagram” on page 9)
23. ___ Tighten the lip chain shackles. (See “Figure 12: Tighten the Shackle” on page 10)
24. ___ Weld or bolt bumpers in place.
25. ___ Ensure that all bolts have been tightened and that all cotter pins and spring pins are in place.
26. ___ Clean and paint the welds using Tremclad High Performance Rust Enamel (Gloss Dark Machine Grey).
27. ___ Lubricate and test in accordance with the Break-in and Performance Check on page 31.

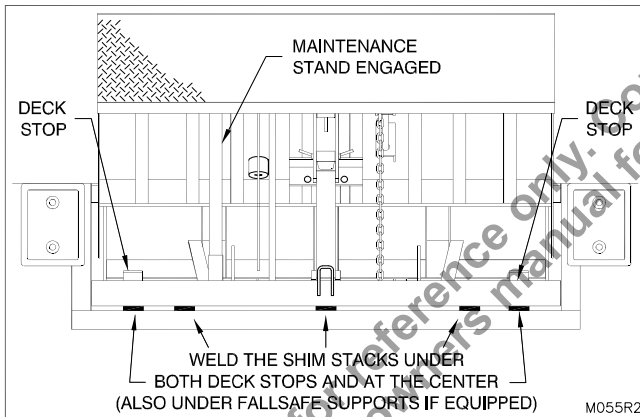

Figure 9: Weld to Front Curb Angle

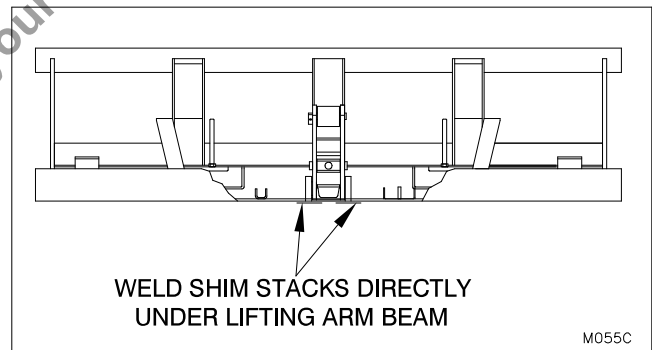

Figure 10: Shim Beneath Lifting Arm Bracket

28. ___ Mount Dock Leveler warning and operating instructions placard close to the Dock Leveler in a location that assures an unobstructed view and Complete Legibility at all times.
29. ___ Meet with the facility manager or maintenance foreman and turn over this maintenance manual with the reminder that instructions in the manual must be followed.
30. ___ Confirm that all steps of the installation instructions have been completed. Fill out the following information.

Your Pentalift mechanical dock leveler has been shipped from the factory adjusted for trouble free performance. It is important to understand that because this is a mechanical device, a “balance” between various mechanisms is required for proper operation. Improper adjustment can deteriorate the performance of your dock leveler and create dangerous situations. Never extend the length of the lip chain. **Any adjustments must be made by factory authorized service technicians.**

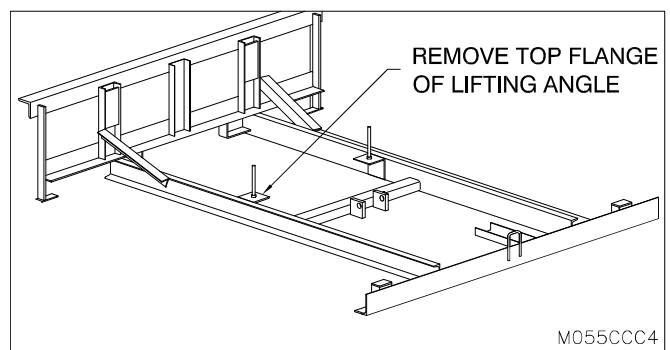

Figure 11: Top Flange Removal Diagram

Note On Capacity: The dock leveler capacity indicated on the serial plate must be divided with a factor to accommodate dynamic loading factors. For more information see Pentalift document - Dock Leveler Capacity – Understanding Loading Dock Capacity at <http://www.pentalift.com/dock-leveler-capacity.php>

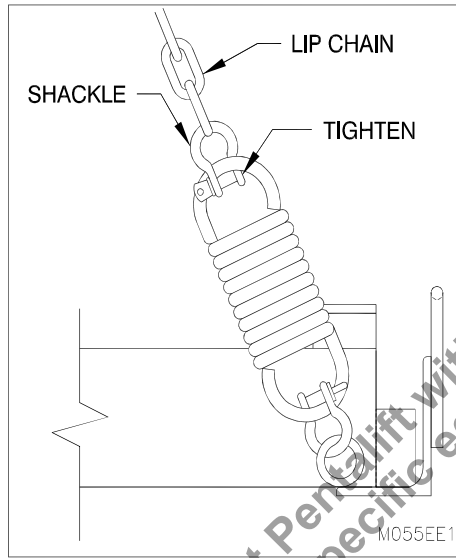

Figure 12: Tighten the Shackle

Installer Name (Print)

Installer Signature

Date Installation Completed

⚠ DANGER

FAILURE TO PROPERLY INSTALL ANY PENTALIFT DOCK LEVELER MAY RESULT IN PROPERTY DAMAGE, BODILY INJURY OR DEATH AND WILL VOID ALL WARRANTIES.

| CAPACITY (lbs) | RECOMMENDED CURB ANGLE SIZE | FORCE (Fa) (lbf) | FORCE (Fb) (lbf) |
|----------------|-----------------------------|------------------|------------------|
| 25000 | 2" X 2" X 3/16" | 7000 | 12000 |
| 30000MC | | 7500 | 13000 |
| 30000MD | | 8000 | 14500 |
| 35000 | | 9500 | 17000 |
| 40000 | | 10500 | 19000 |
| 45000 | | 12000 | 21500 |
| 50000 | | 13000 | 23500 |
| 25000 | 2" X 2" X 3/16" | 7000 | 13000 |
| 30000MC | | 7500 | 14500 |
| 30000MD | | 8000 | 15500 |
| 35000 | | 9500 | 18500 |
| 40000 | | 10500 | 21000 |
| 45000 | | 12000 | 23500 |
| 50000 | | 13000 | 26000 |
| 25000 | 3" X 3" X 3/16" | 7000 | 14000 |
| 30000MC | | 7500 | 15000 |
| 30000MD | | 8000 | 16500 |
| 35000 | | 9500 | 19000 |
| 40000 | | 10500 | 21500 |
| 45000 | | 12000 | 24500 |
| 50000 | | 13000 | 27000 |

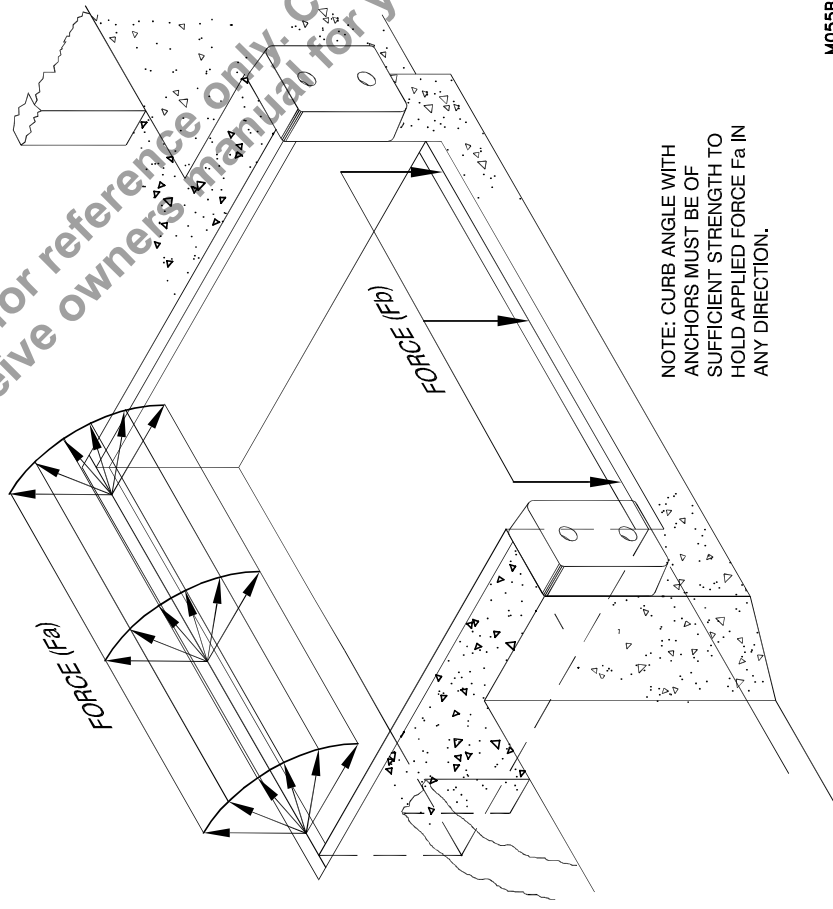

M055BB

Figure 13: Curb Angle Force Chart

INSTALLATION INTO PIT USING SHIM KIT

For units with a nominal depth of 20" being installed into a deeper pit, it will be necessary to install a shim kit. Shim kits are available in standard heights of 1", 2", 3" and 4".

- For 3" or 4" shim kits, weld two rear shims (see Table A) to a single shim plate each (3" x 4" x minimum ASTM A-36 or CSA G40.21 supplied by others) as shown in "Figure 14: Rear Shim (4" Shim Kit Shown)" on page 12. This step adds stability to the shims while installing the dock. This step is not required for 1" or 2" shim kits as the blocks are sufficiently stable as supplied.

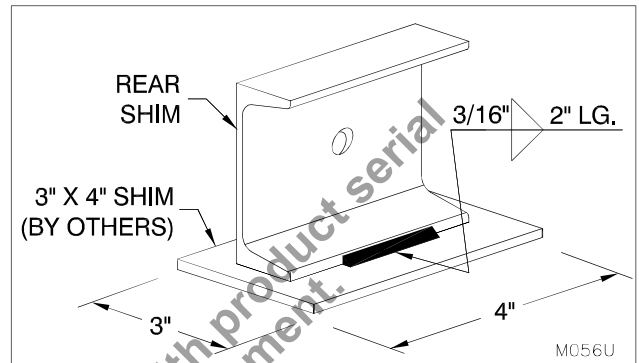

**Figure 14: Rear Shim
(4" Shim Kit Shown)**

Note: On the 25,000 lb model, there will be two rear shims; on 30,000 lb MD models and higher capacities, there will be four. Do not weld the outer rear shims (30,000 lb MD models and higher capacities) at this time.

- Place the two rear shims with welded-on shim plate at the rear of the pit, 35" center to center and 4" from the rear pit wall. (See "Figure 16: Rear Shim Location (4" High Rear Shim Shown)" on page 13)

| Table A - Rear Shims | |
|----------------------|--------------------------------------|
| 4" Shim Kit | C4 Channel x 4" Long |
| 3" Shim Kit | C3 Channel x 4" Long |
| 2" Shim Kit | 2" x 3" x 3/16" Rect. Tube x 4" Long |
| 1" Shim Kit | 1" x 3" Flat Bar x 4" Long |

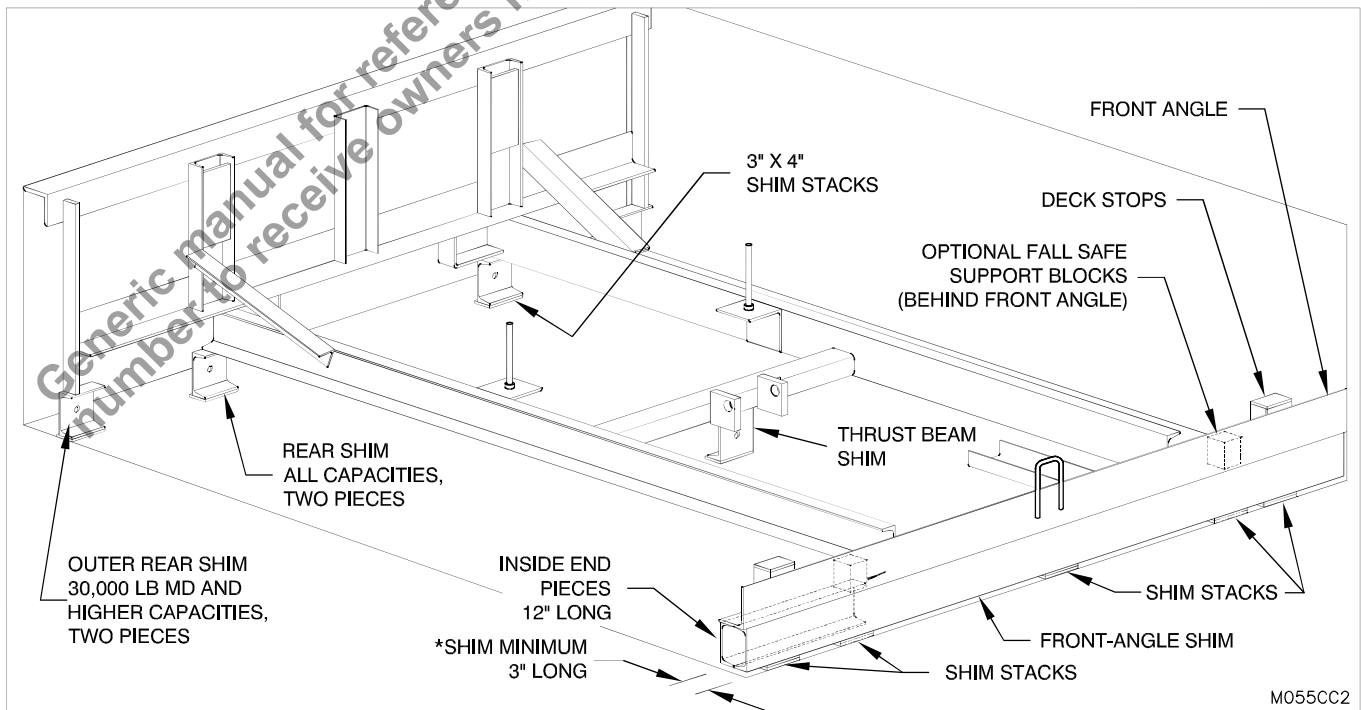
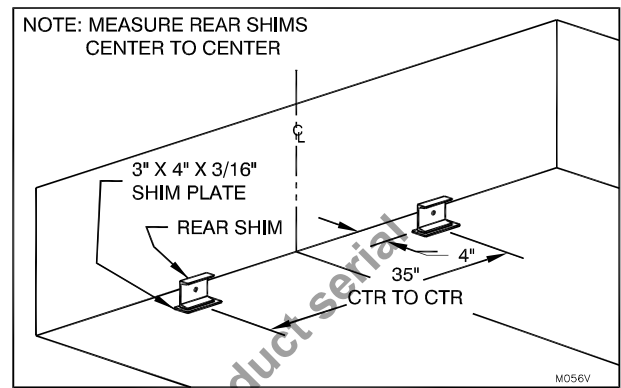

Figure 15: C-channel Shims

3. ___ Place the front-angle shim assembly into the pit at the front edge, centered across the dock leveler and pit width. When the front-angle shim is constructed of C-channel (3" & 4" shim kits) ensure the short pieces (12" long) on each end are installed toward the inside of the pit. (See "Figure 15: C-channel Shims" on page 12).
4. ___ Hoist the leveler into the pit with chain using appropriate lifting devices (See "Figure 17: Hoist Leveler with Chain" on page 13) and position the leveler into the pit opening.
5. ___ Assure that 1" clearance is maintained between the side of the leveler platform and the side pit wall and that the rear angle of the dock leveler is firmly against the rear curb angle of the pit (See "Figure 17: Hoist Leveler with Chain" on page 13).



**Figure 16: Rear Shim Location
(4" High Rear Shim Shown)**

6. ___ **Confirm that the back angle of the dock leveler is firmly against and flush with the top of the rear curb angle and that the dock leveler has remained square in the pit before continuing.**
7. ___ Weld the rear angle of the dock leveler to the rear curb angle of the pit, 1" wide butt weld, at the location of each tilt bar pocket (2 places). (See "Figure 17: Hoist Leveler with Chain" on page 13).
8. ___ Lower the dock leveler until the front angle of the dock leveler rests on the front-angle shim. Ensure the front-angle shim assembly is flush with the front angle of the dock leveler frame.
9. ___ Weld the front-angle shim assembly to the dock leveler frame.
10. ___ Remove the shipping wire. (**CAUTION**, if the shipping wire is not removed, the dock leveler deck and lip will rise once the shipping bolt is removed). Then remove the top shipping bolts and lifting devices. Some units come equipped with a front U-Bracket while others come equipped with a front Half Moon Bracket. If your unit comes with the front U-Bracket then remove the front shipping bolt then remove the U-bracket and clean up the remaining weld to ensure there is no interference with the lip operation. If your unit comes with the Half Moon Bracket, first remove the front shipping bolt and finally remove the Half Moon Bracket and clean up the remaining weld to ensure there is no interference with the lip operation. (See "Figure 17: Hoist Leveler with Chain" on page 13)
11. ___ Operate the dock leveler by pulling the release chain to its full extension and **HOLDING** until the deck's upward movement stops; then let go of the chain and let it fall back into the pocket. Cycle the dock several times to re-align after shipping.
12. ___ Return the dock to the stored position.

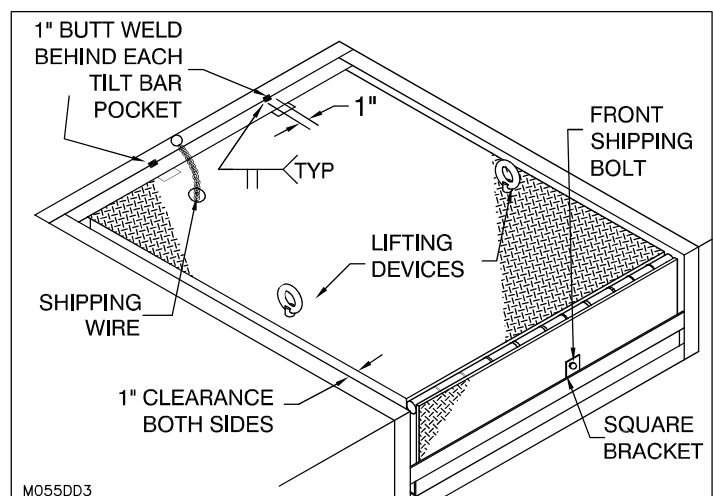

Figure 17: Hoist Leveler with Chain



ALWAYS ENSURE NO ONE IS WITHIN 6 FEET OF THE FRONT (LIP END) OF THE DOCK LEVELER PRIOR TO ACTIVATION. THE HINGED LIP WILL EXTEND RAPIDLY AND LOCK INTO ITS WORKING POSITION DURING UPWARD MOVEMENT OF THE DECK. STAY CLEAR OF DOCK LEVELER WHEN IT IS MOVING.

13. ___ Add shims (3" x 4" x required thickness) to increase the front height of the dock until the deck plate is flush with the dock height (or at desired final level). Ensure shims are located beneath the front-angle shim at the location of the two deck stops as well as at the center of the front angle. (See "Figure 15: C-channel Shims" on page 12 for shim locations.) All shims are to be minimum ASTM A-36 or CSA G40.21 material.

Note: The shim kit is to be installed with a minimum 3" length of front angle support at the headboard stops and, if equipped, at the mechanical fallsafe support blocks.

14. ___ Weld all shims in the stack to the front-angle shim, the front pit curb angle, and each other.
15. ___ Complete welding the back angle of the dock leveler to the rear pit curb angle as shown in "Figure 8: Weld to Rear Curb Angle" on page 8.

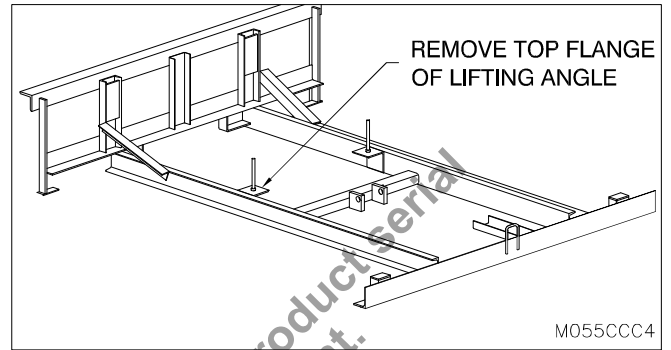

Figure 18: Top Flange Removal Diagram



NEVER GO BENEATH THE DOCK LEVELER UNLESS IT IS PROPERLY SUPPORTED ON THE FRONT SHIMS, THE REAR ANGLE IS SECURELY WELDED AND THE MAINTENANCE STAND IS ENGAGED.

16. ___ Support the dock leveler in accordance with instructions in "SUPPORTING THE LEVELER FOR MAINTENANCE" on page 40.
17. ___ Add shims (3" x 4" x required thickness) between the pit floor and the rear shim to close any gap and fully support the rear of the dock. Fully weld the two rear shims to the frame of the dock leveler and all shim plates in the stack to each other as well as to the rear shim.
18. ___ For 30,000 MD models and higher capacities, weld the additional two rear shims to the outside support bar of the frame as shown in "Figure 19: 30,000 lb + Outer Rear Shims (4" Shim Kit Channel Shim Shown)" on page 14 and shim until they are fully supported. Weld all of the shims to each other as well as to the dock leveler frame.

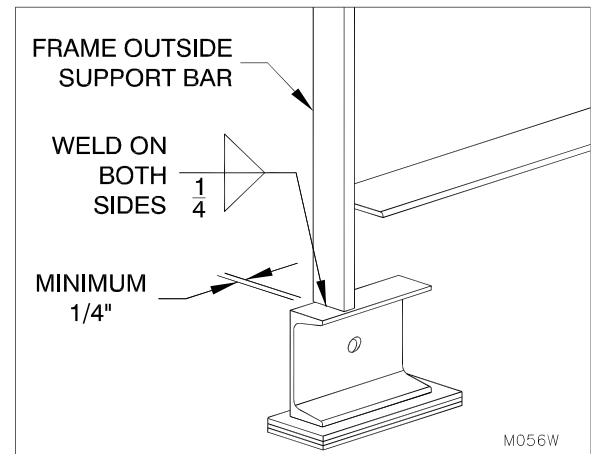

Figure 19: 30,000 lb + Outer Rear Shims (4" Shim Kit Channel Shim Shown)

19. ___ Weld the remaining shim beneath the lifting arm bracket, centered across the width of the beam and flush to the front. (See "Figure 15: C-channel Shims" on page 12) Insert shims beneath until it is fully supported. Weld all shims together as well as to the thrust beam.

NOTE: All shim stacks must be welded together.

20. ___ Once the leveler has been fully installed, remove the top flange of the lifting angle to allow clearance for the Hold Down Release Bar. (See "Figure 18: Top Flange Removal Diagram" on page 14)
21. ___ For units with full range toe guards, support the lower half of the toe guard and remove the self tapping screw which holds it in the shipping position. (See "Figure 3: Hoist Using Lifting Devices" on page 6) Carefully lower the toe guard and avoid pinch points.
22. ___ Tighten the lip chain shackle. (See "Figure 12: Tighten the Shackle" on page 10)

23. Weld or bolt bumpers in place.
24. Ensure that all bolts have been tightened and that all cotter pins and spring pins are in place.
25. Clean and paint the welds using Tremclad High Performance Rust Enamel (Gloss Dark Machine Grey).
26. Mount Dock Leveler warning and operating instructions placard close to the Dock Leveler in a location that assures an unobstructed view and Complete Legibility at all times.
27. Lubricate and test in accordance with the Break-in and Performance Check on page 31.
28. Meet with the facility manager or maintenance foreman and turn over this maintenance manual with the reminder that instructions in the manual must be followed.
29. Confirm that all steps of the installation instructions have been completed. Fill out the following information.

Installer Name (Print)

Installer Signature

Date Installation Completed

Your Pentalift mechanical dock leveler has been shipped from the factory adjusted for trouble free performance. It is important to understand that because this is a mechanical device, a “balance” between various mechanisms is required for proper operation. Improper adjustment can deteriorate the performance of your dock leveler and create dangerous situations. Never extend the length of the lip chain. **Any adjustments must be made by factory authorized service technicians.**

Note On Capacity: The dock leveler capacity indicated on the serial plate must be divided with a factor to accommodate dynamic loading factors. For more information see Pentalift document - Dock Leveler Capacity – Understanding Loading Dock Capacity at <http://www.pentalift.com/dock-leveler-capacity.php>



FAILURE TO PROPERLY INSTALL ANY PENTALIFT DOCK LEVELER MAY RESULT IN PROPERTY DAMAGE, BODILY INJURY OR DEATH AND WILL VOID ALL WARRANTIES.

INSTALLATION USING FILLER PLATE

INSTALLATION INSTRUCTIONS FOR 3-INCH FILLER PLATE

1. Before installing the filler plate and dock leveler, read the INSTALLATION INSTRUCTIONS FOR PIT MODEL MECHANICAL DOCK LEVELERS section of the owner’s manual on page 5.
2. Position the 3 inch square tube against the rear curb angle and flush to the top surface of the curb angle.
3. Weld the ends of the square tubing to the side curb angle (see “Figure 20: Welding the 3 X 3 Square Tubing to the Curb Angles” on page 16). Add vertical welds at the ends of the tube between tube surface and side curb angle surface.
4. Note the centerline positions of the tilt bar pockets on the dock leveler.
5. Transfer the centerline positions to the square tube.

6. ___ Weld 1 inch butt weld at the mark off locations on the square tube
7. ___ Based on the dock leveler's rated capacity, see WELDING REFERENCE CHARTS on page 8 to determine the length of the weld for dimension "A".
8. ___ Refer to the rest of the installation section of the owner's manual to install the dock leveler.
9. ___ Confirm that all steps of the installation instructions have been completed. Fill out the following information.

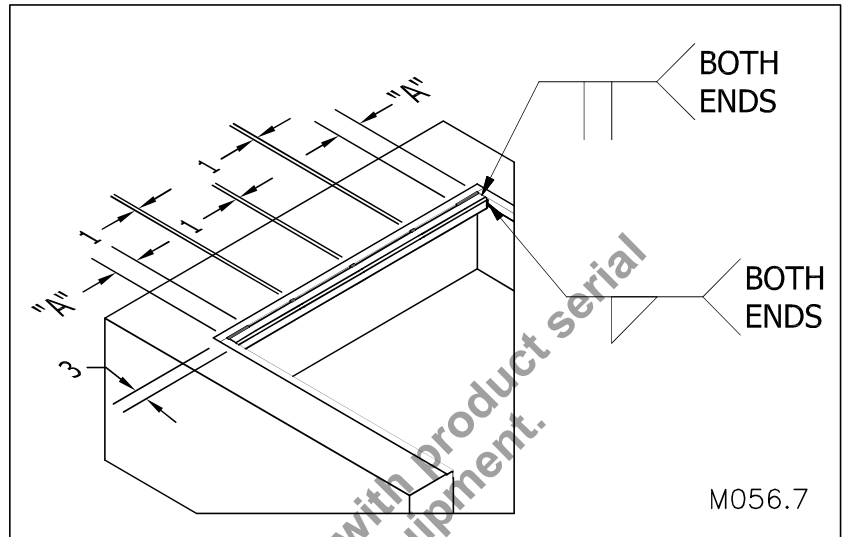

Figure 20: Welding the 3 X 3 Square Tubing to the Curb Angles

Installer Name (Print)

Installer Signature

Date Installation Completed

INSTALLATION INSTRUCTIONS FOR 4-INCH FILLER PLATE

1. ___ Before installing the filler plate and dock leveler, read the INSTALLATION INSTRUCTIONS FOR PIT MODEL MECHANICAL DOCK LEVELERS section of the owner's manual on page 5.
2. ___ Position the 4 X 3 inch rectangular tube against the rear curb angle and flush to the top surface of the curb angle.
3. ___ Weld the ends of the rectangular tubing to the side curb angle (see "Figure 21: Welding the 4 X 3 Rectangular Tubing to the Curb Angles" on page 16). Add vertical welds at the ends of the tube between tube surface and side curb angle surface.
4. ___ Note the centerline positions of the tilt bar pockets on the dock leveler.
5. ___ Transfer the centerline positions to the rectangular tube.
6. ___ Weld 1 inch butt weld at the mark off locations on the rectangular tube
7. ___ Based on the dock leveler's rated capacity, see WELDING REFERENCE CHARTS on page 8 to determine the length of the weld for dimension "A".

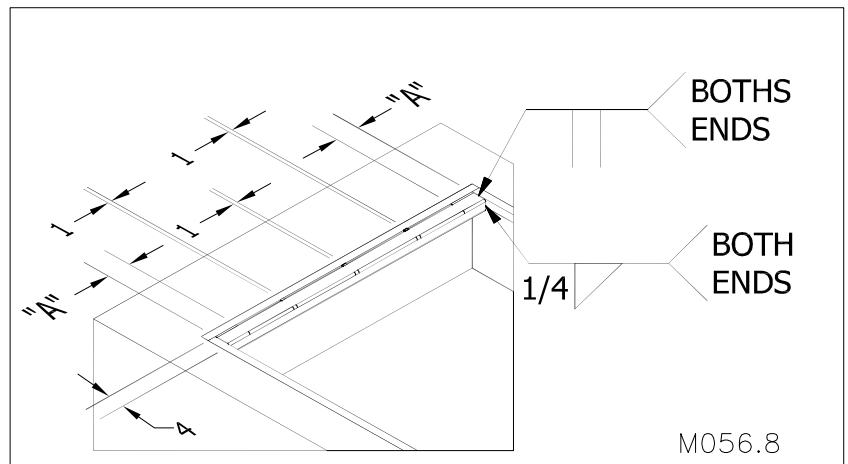

Figure 21: Welding the 4 X 3 Rectangular Tubing to the Curb Angles

8. ___ Refer to the rest of the installation section of the owner's manual to install the dock leveler.
9. ___ Confirm that all steps of the installation instructions have been completed. Fill out the following information.

Installer Name (Print)

Installer Signature

Date Installation Completed

FILLER PLATE INSTALLATION INSTRUCTIONS (WITH TWO TUBES & TWO SUPPORT BARS)

1. ___ Before installing the filler plate and dock leveler, read the INSTALLATION INSTRUCTIONS FOR PIT MODEL MECHANICAL DOCK LEVELERS section of the owner's manual on page 5.
2. ___ Locate the two support bars on one of the rectangular tubes. The support bar should be positioned halfway between the center span of the tube to the end of the tube.
3. ___ Weld the support bars in place using full fillet welds.
4. ___ Slip the levelling tubes over the support bars and lightly tack in place so that it does not fall off while inverting the rectangular tube as indicated in "Figure 22: Welding the 4 X 3 Rectangular Tubing to the Curb Angles" on page 17.
5. ___ Position the 4 X 3 inch rectangular tubes as indicated in "Figure 22: Welding the 4 X 3 Rectangular Tubing to the Curb Angles" on page 17. Make sure the top surface of the rectangular tube is $\frac{1}{4}$ " below the top surface of the curb angle. This will allow the filler plate to be welded flush to the top surface of the curb angle.
6. ___ Weld the ends of the rectangular tubing to the side curb angle as indicated in "Figure 22: Welding the 4 X 3 Rectangular Tubing to the Curb Angles" on page 17. Add vertical welds at the ends of the tube between tube surface and side curb angle surface.
7. ___ Remove the tack weld from step 4 and allow the levelling tubes to settle to the pit floor.
8. ___ Weld the levelling tubes to the support bars using full fillet welds as indicated in "Figure 22: Welding the 4 X 3 Rectangular Tubing to the Curb Angles" on page 17.

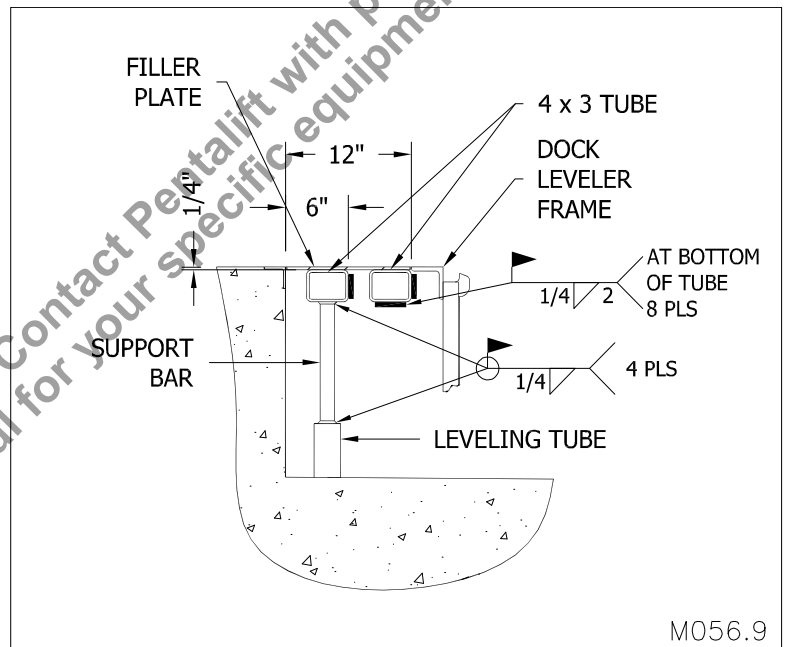

Figure 22: Welding the 4 X 3 Rectangular Tubing to the Curb Angles

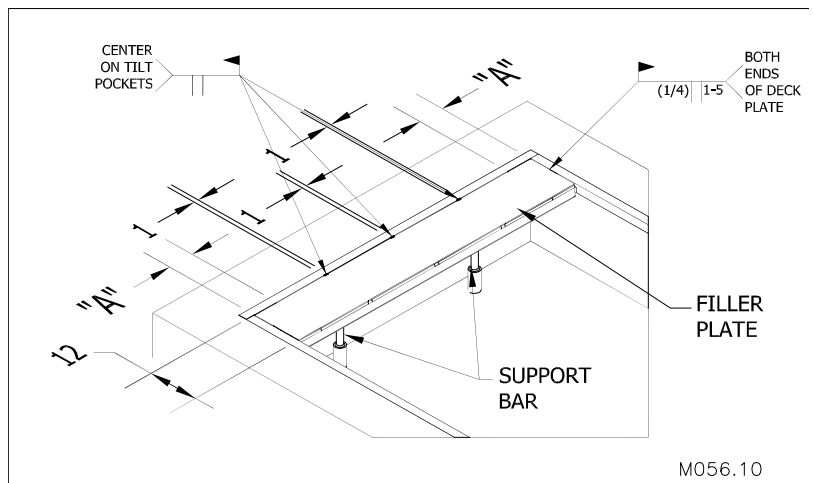

Figure 23: Installing the filler plate

9. ___ Note the centerline positions of the tilt bar pockets on the dock leveler.
10. ___ Transfer the centerline positions to the back side of the filler plate that will adjoin the rear curb angle.
11. ___ Place the filler plate on top of the rectangular tubes as indicated in "Figure 23: Installing the filler plate" on page 17 making sure the filler plate sits flat and square to the rear and side curb angles.
12. ___ Weld 1 inch butt weld at the mark off locations on the deck plate as indicated in "Figure 23: Installing the filler plate" on page 17.
13. ___ Based on the dock leveler's rated capacity, see WELDING REFERENCE CHARTS on page 8 to determine the length of the weld for dimension "A".
14. ___ Refer to the rest of the installation section of the owner's manual to install the dock leveler.
15. ___ Confirm that all steps of the installation instructions have been completed. Fill out the following information.

Installer Name (Print)

Installer Signature

Date Installation Completed

FILLER PLATE INSTALLATION INSTRUCTIONS (WITH TWO TUBES & FOUR SUPPORT BARS)

1. ___ Before installing the filler plate and dock leveler, read the INSTALLATION INSTRUCTIONS FOR PIT MODEL MECHANICAL DOCK LEVELERS section of the owner's manual on page 5.
2. ___ Locate the two support bars on the rectangular tubes (two support bars per rectangular tube). The support bar should be positioned halfway between the center span of the tube to the end of the tube.
3. ___ Weld the support bars in place using full fillet welds.
4. ___ Slip the levelling tubes over the support bars and lightly tack in place so that it does not fall off while inverting the rectangular tube as indicated in "Figure 24: Welding the 4 X 3 Rectangular Tubing to the Curb Angles" on page 18.
5. ___ Position the 4 X 3 inch rectangular tubes as indicated in "Figure 24: Welding the 4 X 3 Rectangular Tubing to the Curb Angles" on page 18. Make sure the top surface of the rectangular tube is 1/4" below the top surface of the curb angle. This will allow the filler plate to be welded flush to the top surface of the curb angle.
6. ___ Weld the ends of the rectangular tubing to the side curb angle as indicated in "Figure 24: Welding the 4 X 3 Rectangular Tubing to the Curb Angles" on page 18. Add vertical welds at the ends of the tube between tube surface and side curb angle surface.

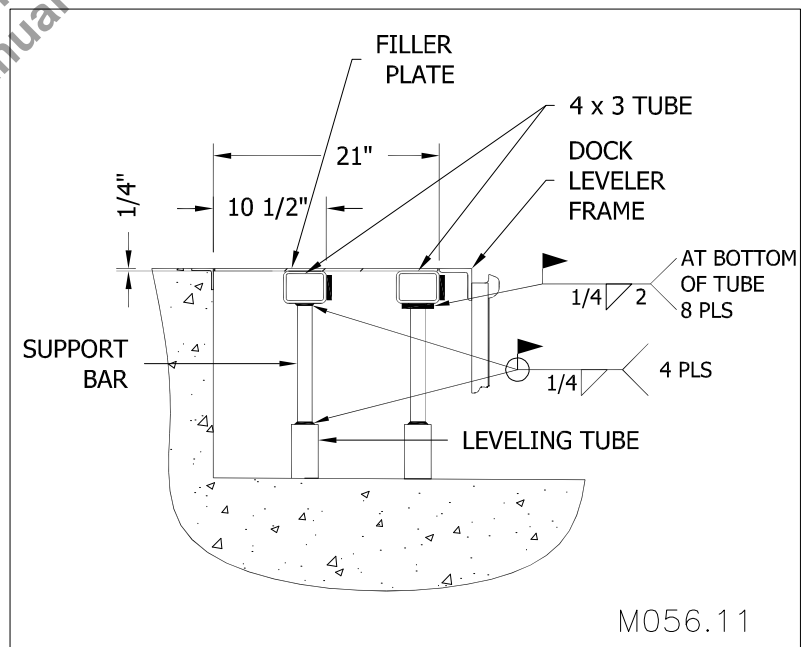

Figure 24: Welding the 4 X 3 Rectangular Tubing to the Curb Angles

7. Remove the tack weld from step 4 and allow the levelling tubes to settle to the pit floor.
8. Weld the levelling tubes to the support bars using full fillet welds as indicated in "Figure 24: Welding the 4 X 3 Rectangular Tubing to the Curb Angles" on page 18.
9. Note the centerline positions of the tilt bar pockets on the dock leveler.
10. Transfer the centerline positions to the back side of the filler plate that will adjoin the rear curb angle.
11. Place the filler plate on top of the rectangular tubes as indicated in "Figure 25: Installing the filler plate" on page 19 making sure the filler plate sits flat and square to the rear and side curb angles.
12. Weld 1 inch butt weld at the mark off locations on the deck plate as indicated in "Figure 25: Installing the filler plate" on page 19.
13. Based on the dock leveler's rated capacity, see WELDING REFERENCE CHARTS on page 8 to determine the length of the weld for dimension "A".
14. Refer to the rest of the installation section of the owner's manual to install the dock leveler.
15. Confirm that all steps of the installation instructions have been completed. Fill out the following information.

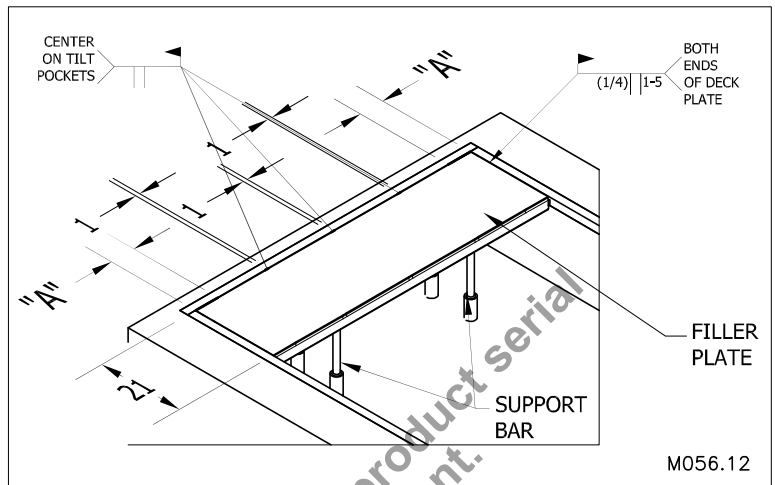

Figure 25: Installing the filler plate

Installer Name (Print)

Installer Signature

Date Installation Completed

INSTALLATION PICTURES

Upon completion of installation, photograph the following views as depicted below. Keep photos with owners manual.

1. ___ Front angle shims. (See “Figure 26: Front Angle and Optional Fallsafe Support Block Shims” on page 20)
2. ___ Fall safe support block shims. (See “Figure 26: Front Angle and Optional Fallsafe Support Block Shims” on page 20)
3. ___ Rear shims (Left and Right side). (See “Figure 28: Rear Shims” on page 21)
4. ___ Thrust beam shims. (See “Figure 27: Thrust Beam Shims” on page 20)
5. ___ Rear angle of dock leveler in parked position showing flush and level to the floor/curb angle. (See “Figure 29: Rear Angle Flush with Curb Angle” on page 21)

Installer Name (Print)

Installer Signature

Date Installation Completed

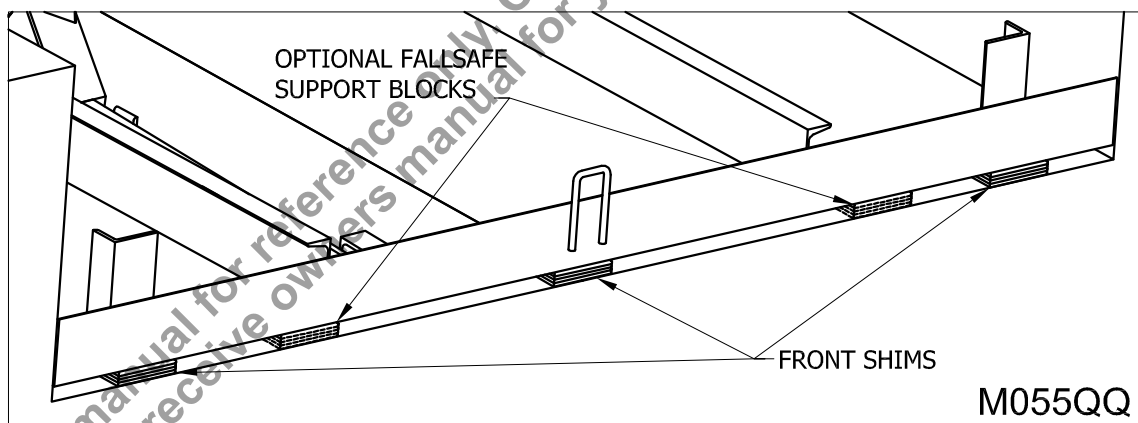

Figure 26: Front Angle and Optional Fallsafe Support Block Shims

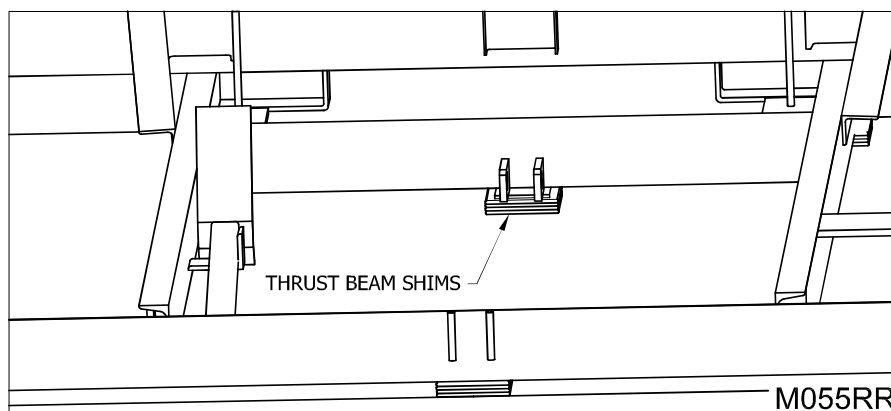

Figure 27: Thrust Beam Shims

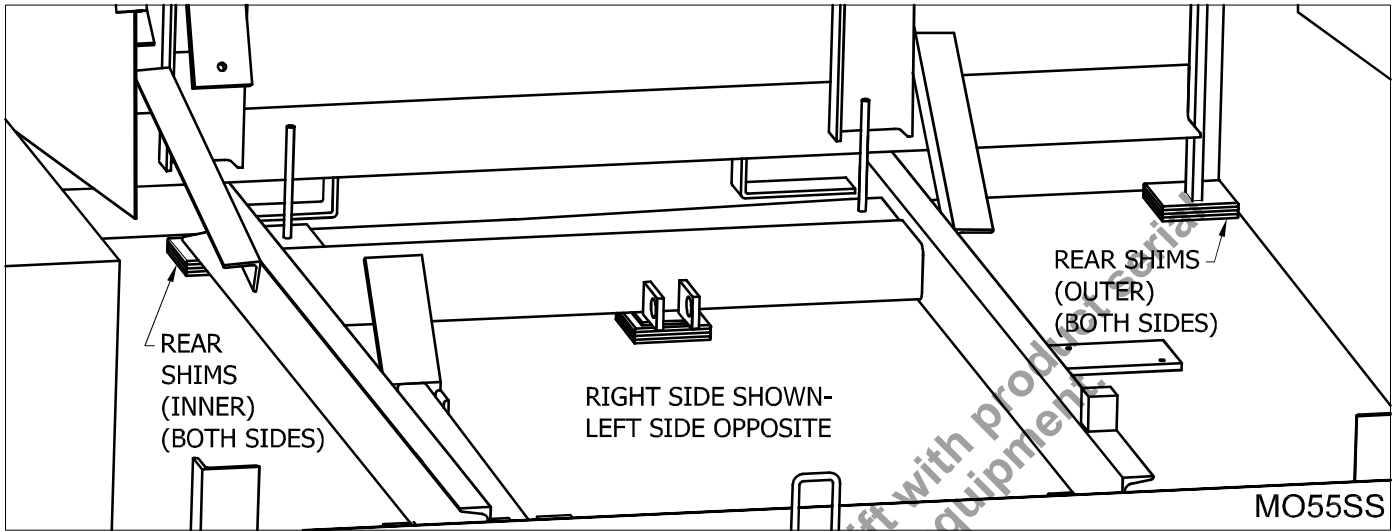

Figure 28: Rear Shims

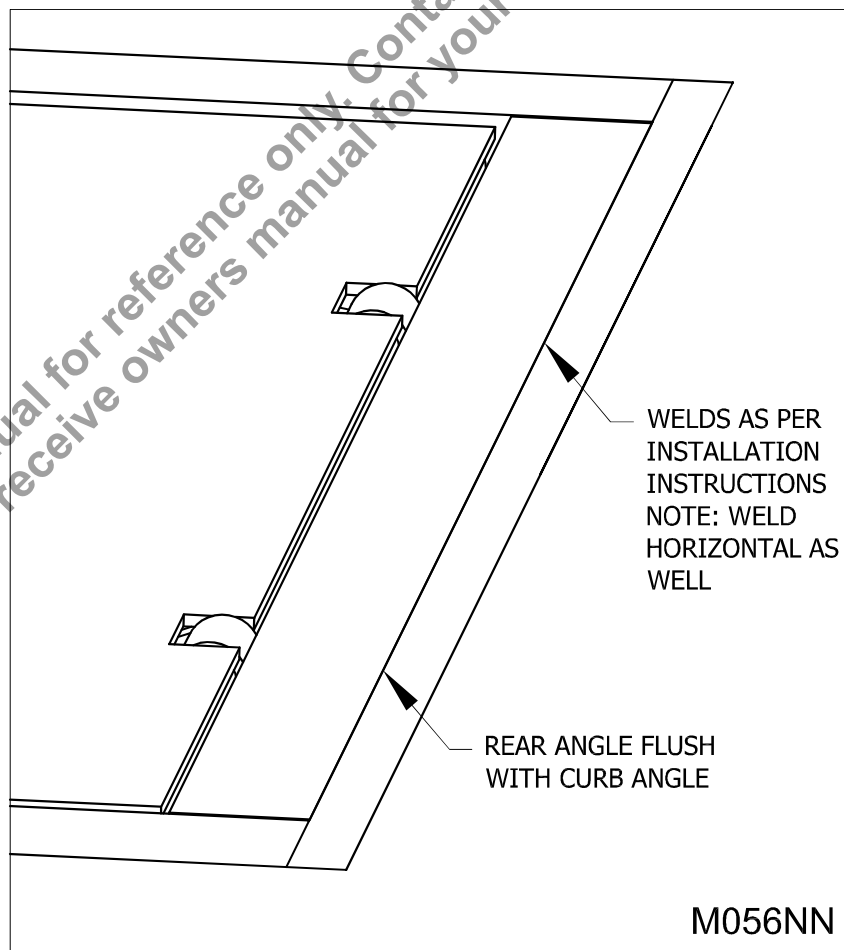

Figure 29: Rear Angle Flush with Curb Angle

INSTALLATION INSTRUCTIONS

POUR-IN DOCK LEVELERS



- WIRING MUST BE DONE BY A QUALIFIED ELECTRICIAN.
- ALWAYS USE APPROPRIATE LOCK-OUT PROCEDURES DURING ANY ELECTRICAL INSTALLATIONS.
- ENSURE SUPPLY VOLTAGE IS CORRECT.
- ON 3 PHASE UNITS ASSURE PHASE POLARITY IS CORRECT.
- ALWAYS OBSERVE ALL APPLICABLE ELECTRICAL CODES.

NOTE: A very high level of field issues with this type of equipment can be directly attributed to improper or incomplete installation. The installation instructions and information provided for this equipment is thorough. A step by step sequence for installation is provided. All steps must be followed and completed to provide a complete installation. Incomplete or improper installations can lead to equipment malfunction and / or damage, create safety issues and void warranties. Please follow all installation and set ups steps as indicated in the installation instructions and owner's manual. If you are unclear or uncertain regarding any of the steps contact your Pentalift representative for clarification. A copy of the completed steps listing with the sign off and photos of the installation as indicated at the conclusion of the installation instructions will be required prior to any Pentalift factory trouble shooting assistance.

IMPORTANT

PREPARATION PRIOR TO INSTALLATION

NOTE: Prior to accepting shipment and pouring, check pour-in pan and structural angle for damage. Perform installation instructions in the same sequence as they are listed below. To accommodate a complete installation there is a blank space provided beside each numbered step in the installation instructions. Please check off the steps sequentially as they are completed. This will assist in confirming a complete installation.

IMPORTANT: In some instances shipping and handling can result in damage to the dock leveler. Prior to accepting the shipment and prior to installing the equipment check the dock leveler for damage. Be sure to check the pour-in pan components and the pour in angles (See "Figure 30: Pour-In Pan Components" on page 23).

If damage does exist:

- 1) Do not accept the shipment until you have made a damaged notation on the delivery receipt. It is the consignees obligation to count and examine the condition of the shipment at the time of the delivery.
- 2) Do not install the equipment until appropriate repairs are made.
- 3) Contact your Pentalift representative for assistance.



Before doing any installation, maintenance, inspection or trouble shooting, barricade all areas from traffic around the work area inside (and outside if applicable) for safety and post appropriate warning signs.

⚠ DANGER

Before doing any electrical work, be certain that the power is disconnected with a fused disconnect, properly tagged and locked out. Fused disconnect and lockout device (supplied and installed by others) must meet with all applicable codes and regulations. All electrical work must be performed by a qualified electrician in accordance with all applicable codes and regulations.

⚠ DANGER

MAKE SURE LIFTING AND SLINGING DEVICES ARE OF SUFFICIENT CAPACITY, USED IN THE CORRECT MANNER AND ARE IN GOOD WORKING ORDER. ALL LIFTING, POSITIONING AND INSTALLATION, AS WELL AS THE BREAK-IN AND PERFORMANCE CHECK MUST BE DONE BY QUALIFIED PERSONNEL TRAINED AND EXPERIENCED IN NECESSARY SAFETY PROCEDURES.

⚠ DANGER

NEVER GO BENEATH THE DOCK LEVELER FOR ANY REASON UNLESS THE DECK AND LIP ARE PROPERLY SUPPORTED (SEE "HOW TO SUPPORT..." IN THE OWNER'S MANUAL) AND THE POWER IS DISCONNECTED, PROPERLY TAGGED AND LOCKED OUT. IT IS THE RESPONSIBILITY OF THE OWNER TO ENSURE THAT NO LOAD NOR TRAFFIC IS PLACED ON THE DECK WHILE THE MAINTENANCE STAND IS ENGAGED. THE CONSTRUCTION OF THE MAINTENANCE STAND IS INTENDED TO SUPPORT THE WEIGHT OF THE UNLOADED DOCK LEVELER ONLY.

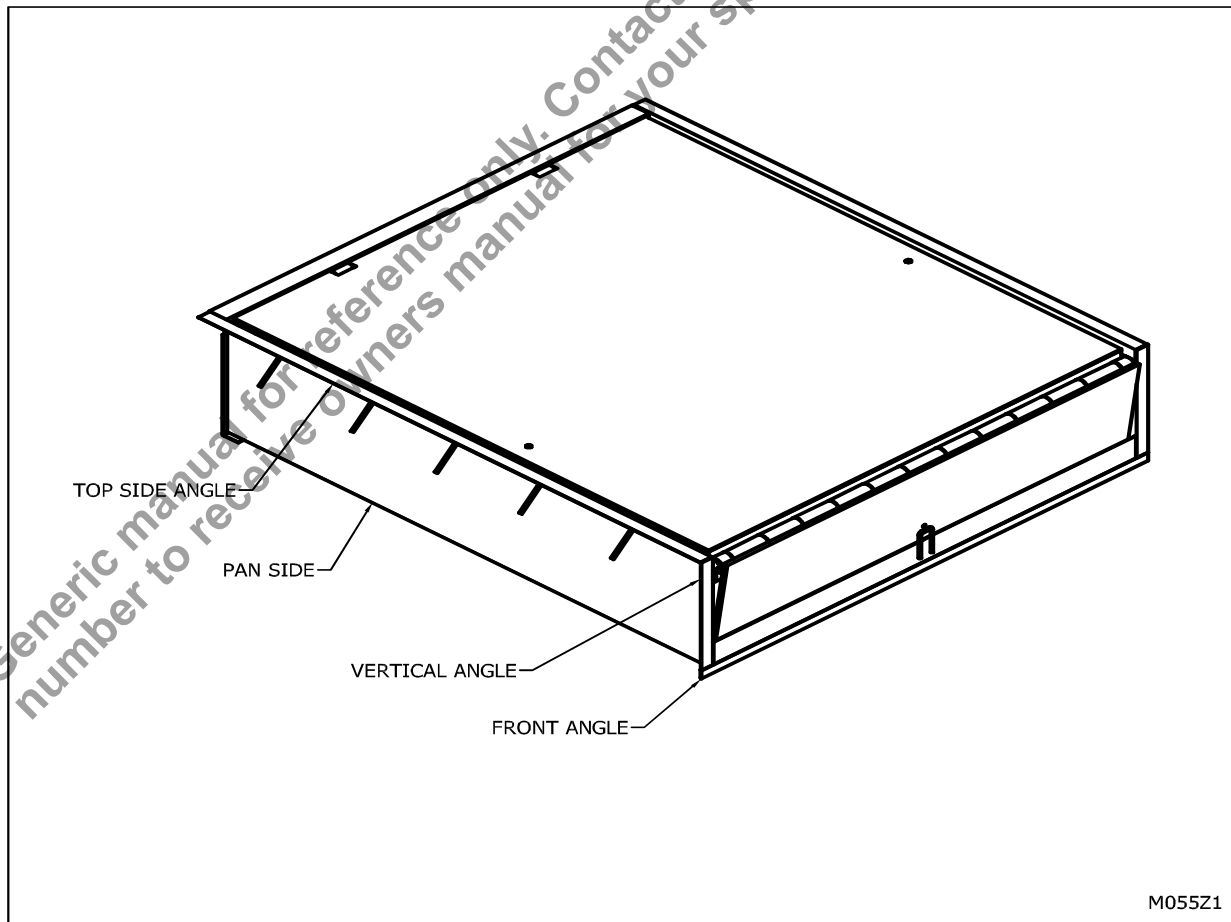

Figure 30: Pour-In Pan Components

1. ___ Find the pre-determined floor level (See “Figure 31: Foundation cut out and support pad” on page 24) and ensure the foundation cut-out and support pad are in place to properly locate and support the dock leveler is appropriate according to the sizes shown on the dock leveler drawing provided by the Pentalift. For the dimensions of the foundation cut-out refer to Pentalift drawing 260-4755.

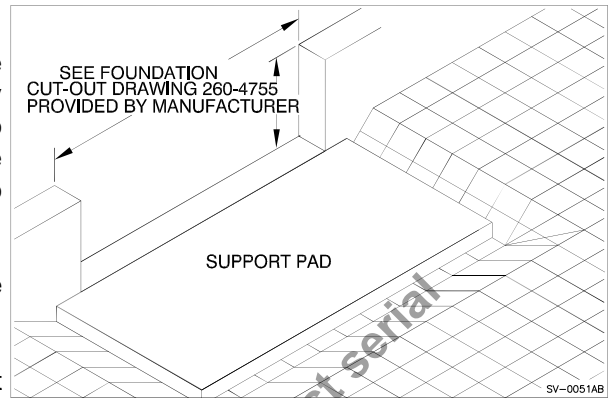

Figure 31: Foundation cut out and support pad

2. ___ Position the dock leveler into the foundation cutout (see “Figure 32: Dock Leveler in Position” on page 25).
3. ___ Shim the front and rear of the dock to the desired, correct and level position. Confirm side to side positioning at the pre-determined floor level.
4. ___ Ensure there is a one inch (1”) gap between the deck and side pan curb angle. Confirm this on both sides of the dock leveler. Once the gaps are confirmed as correct, ensure the adjusting bolts are in contact with the side panels. See “Figure 33: One Inch (1”) Gap” on page 25. Use the adjusting bolts to increase the gap to 1” if required.
5. ___ Securely brace the dock leveler to prevent any movement or “floating” during the pouring of the concrete. Use lag bolts in the provided lagging brackets to assist in securing the dock leveler (see “Figure 32: Dock Leveler in Position” on page 25). Note that these brackets are intended to assist in bracing the dock leveler and that consideration and use of additional supporting means may be required.
6. ___ Prior to pouring the concrete, confirm that pour-in pan sides and top side angles are straight and undamaged, reconfirm that the pan structure will maintain a 1” gap between edge of the dock leveler deck and the finished pan side walls for the entire length of the deck.
7. ___ Prior to pouring the concrete, re-examine the front and rear of the unit to ensure the top of the unit has remained level and in the desired final position. Once the concrete has been poured around the dock leveler, repositioning the dock leveler is very difficult and expensive.
8. ___ Pour concrete to finished floor level and flush with the curb angle on all three (3) sides in **two stages**.

NOTE: Care must be taken when placing concrete around pan of the dock leveler. Excessive concrete force on the pan components will cause distortion and or deflection of the pan assembly. It may also cause the dock leveler to move from the desired final position. This could create many serious issues including and not limited to; impeding the required movement of the dock leveler. Creating misalignment of the dock leveler with the trucks and trailers, and look bad visually. It is very important to not create excessive forces onto dock leveler pan components. Concrete tampers or compactors should be used carefully as these can create high forces.

First Stage – allow concrete to flow under entire base of pan and ten inches (10”) up the sides. The purpose of this pour is to have the concrete flow under dock leveler for proper below frame support and to further support and hold the dock leveler in the desired location during the second stage pour. Allow the concrete to cure to full strength.

Second Stage – fill to pre-determined floor level and flush with the curb angle on all three (3) sides.

9. ___ Remove all excess concrete.
10. ___ Once the concrete is cured, remove the side adjusting bolts. (see “Figure 33: One Inch (1”) Gap” on page 25)
11. ___ Remove the shipping wire. Then remove the top shipping bolts (if equipped) and front shipping bolts and lifting brackets. (See “Figure 34: Shipping Wire, Bolts and Lifting Devices.” on page 25)
12. ___ For any model of mechanical dock leveler, review the position of the top edge dock leveler deck relative to the top of the curb angle (See “Figure 35: Deck Alignment” on page 26). If the deck is too low in relation to the installation requirements, shim the dock leveler using steel shim(s) on both sides as indicated in “Figure 36: Shimming 16” & 18” Lips” on page 26 and in “Figure 36A: Shimming 20” Lips” on page 26.

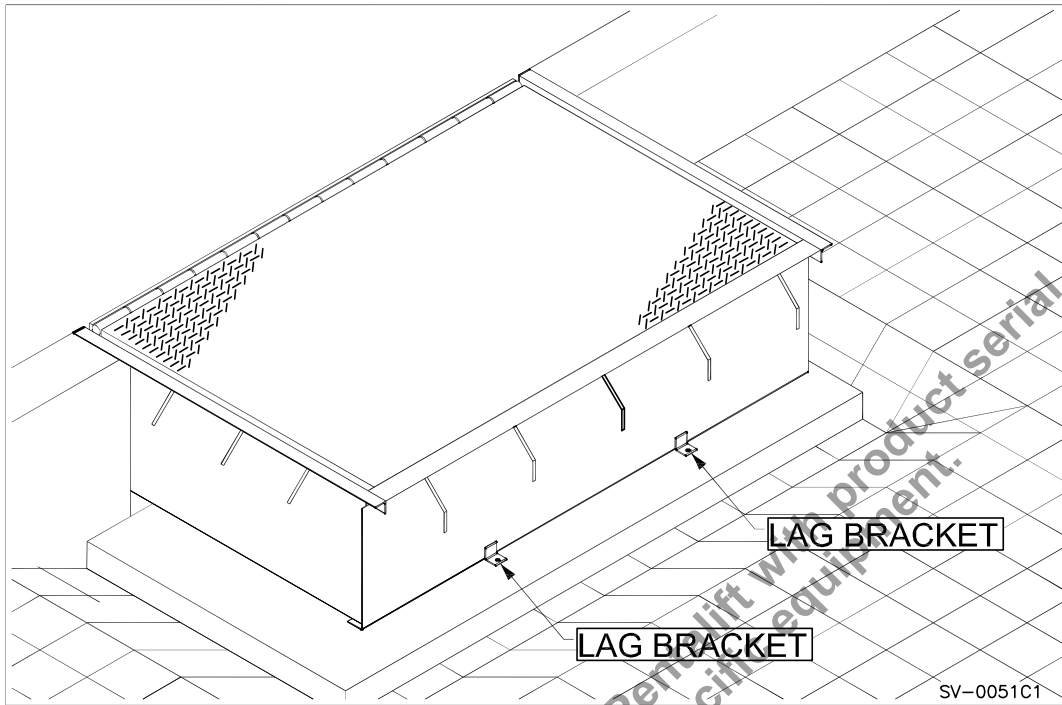

Figure 32: Dock Leveler in Position

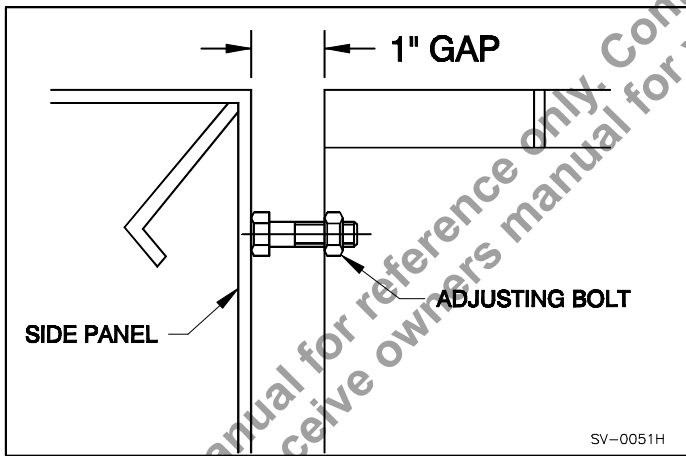

Figure 33: One Inch (1'') Gap

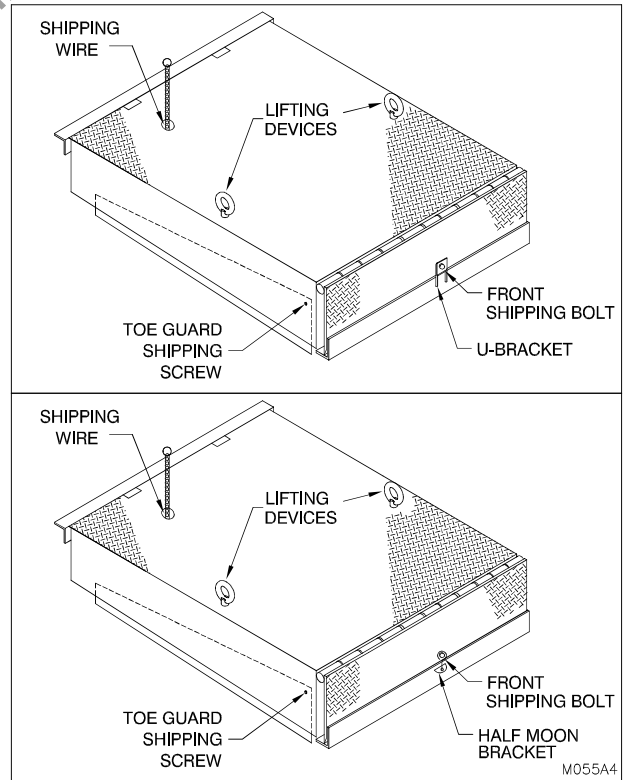

Figure 34: Shipping Wire, Bolts and Lifting Devices.

 Installer Name (Print)

 Installer Signature

 Date Installation Completed

⚠ DANGER

FAILURE TO PROPERLY INSTALL ANY PENTALIFT DOCK LEVELER MAY RESULT IN PROPERTY DAMAGE, BODILY INJURY OR DEATH AND WILL VOID ALL WARRANTIES.

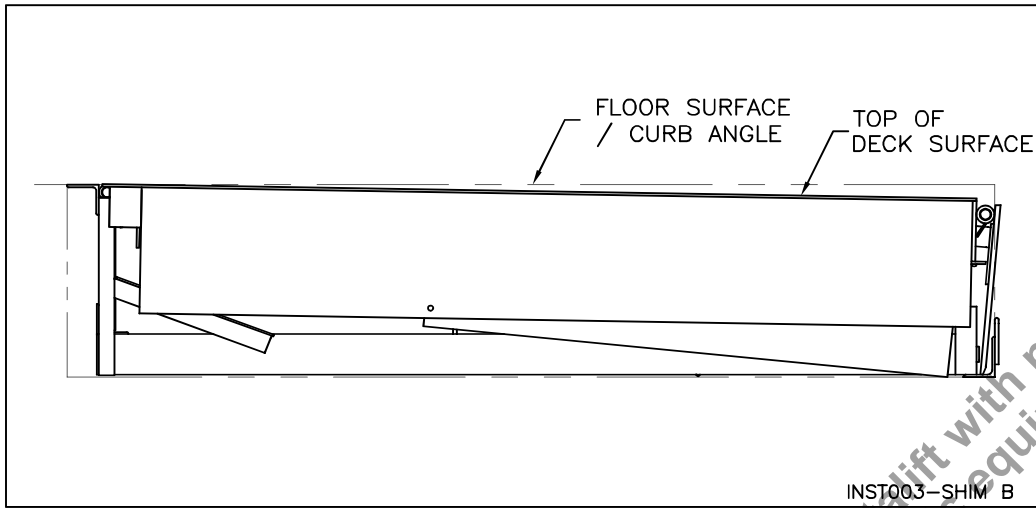

Figure 35: Deck Alignment

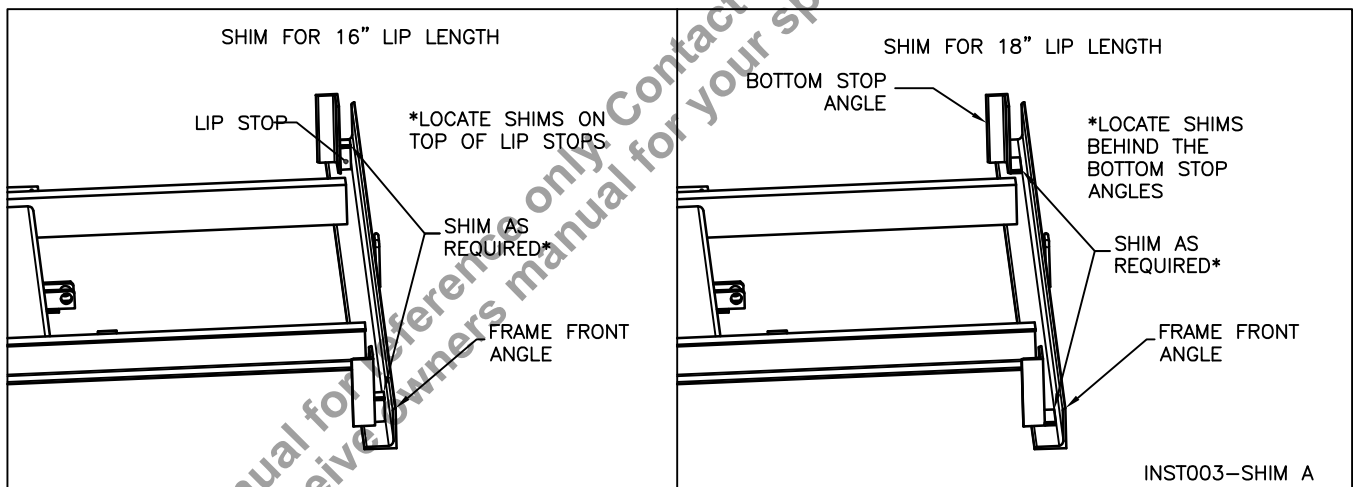

Figure 36: Shimming 16" & 18" Lips

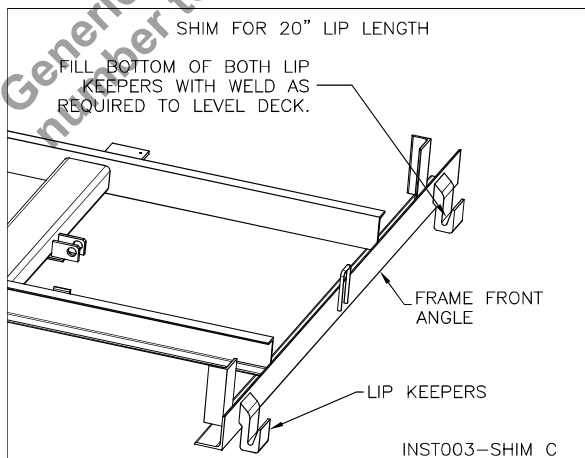

Figure 36A: Shimming 20" Lips

INSTALLATION PICTURES

Upon completion of installation, photograph the following views as depicted below. Keep photos with owners manual.

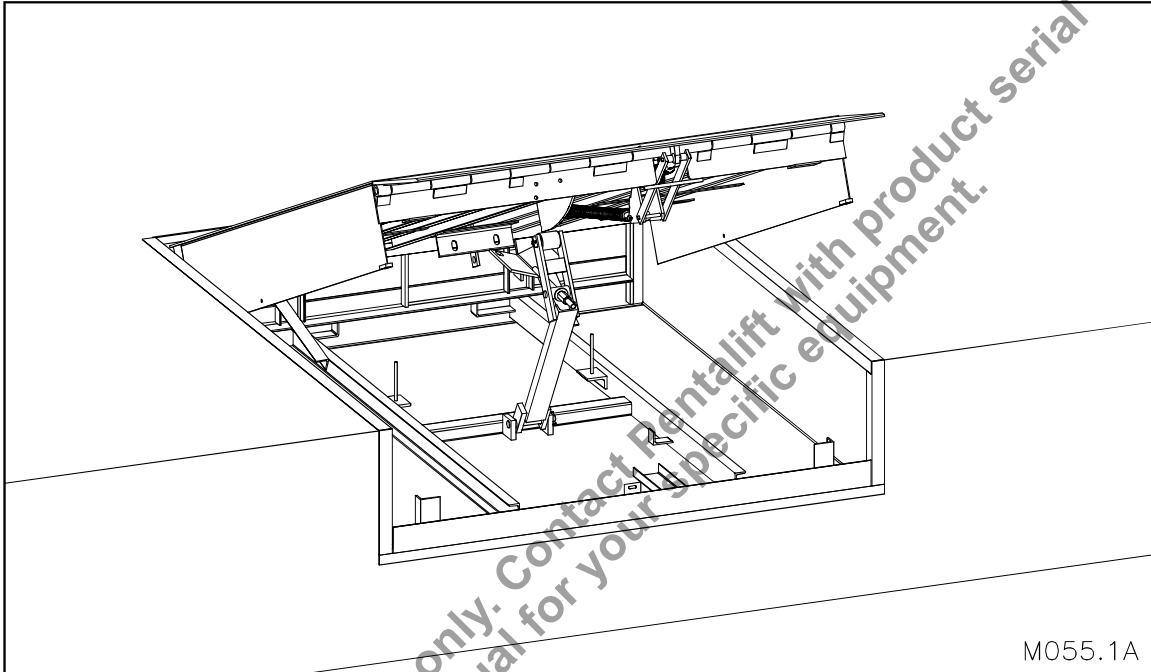

Figure 37: Dock Leveler Installed

Installer Name (Print)

Installer Signature

Date Installation Completed

Bumper Installation Guide lines

LOCATING DOCK BUMPERS DURING INSTALLATION:

1. For the majority of pit type dock leveler installations the dock bumpers are vertically positioned with the top edge of the bumper flush with the top of the loading dock wall face adjacent to top of the dock leveler pit vertical wall. (of the top of where the dock face meets the dock floor.)
2. For the majority of pit type dock leveler installations the dock bumpers are horizontally positioned with the inside edge of the bumper as close to the vertical edge of the dock leveler pit wall as reasonably possible.
3. Note: The word majority is utilized in the above two statements because there may be exceptions to these rules. The purpose of the dock bumper is to create a designed impact area for approaching truck / trailer traffic. If the above location guidelines would result in locating the bumper such that it will not be properly impacted by the truck and trailers intended to be serviced at the facility, adjustments in positioning and the actual bumper arrangements may be required. Remember that trucks and trailers come in different physical configurations and sizing. The dock bumpers should be positioned to accommodate all the variations that will be serviced. Bumper risers are optionally added to accommodate lower dock heights and / or higher trucks. Bumper extensions or projected pits are optionally added to accommodate applications where the normal bumper projection is insufficient such as declined dock approaches. Contact your Pentalift representative for more information or guidelines to suit a specific application.

Installation methods I.E. Lagging and or welding:

1. Dock bumpers are generally attached in two ways; 1) utilization of concrete lag bolts or 2) welding in position. The use of these two methods depends on the type and configuration of the bumpers selected and the actual installation location.
2. It is quite common for the installation to be a combination of concrete lag bolts and welding.
3. When concrete lag bolts are utilized the dock bumper is usually provided with holes or has a bracket(s) on it with holes to accommodate the lagging. The dock bumper can be moved into the correct final position and used as a template to mark the required hole location for the lag bolts. Lag bolts that accommodate a minimum tensile value of 8710kN and shear value of 12015kN are to be utilized. Confirm the concrete arrangement and composition as well the that bumper hole location provides sufficient concrete material and strength to accommodate the selected lag bolts. Install the lag bolts according to the lag bolt manufacturer's instructions.
4. For welding attachment of bumpers, both the dock bumper and the loading dock area must be designed to accommodate. Typically the bumper will be provided with a flat bar (in place of the bracket with holes). That flat bar will line up with a steel surface that has been located and is suitably anchored into the dock face. Weld the dock bumper flat bar with ¼" welds and 2" stitches a maximum of 4" apart. More weld is better than not enough. Clean and paint the welds after application and cooling.

DB13 Bumper Typical Installation

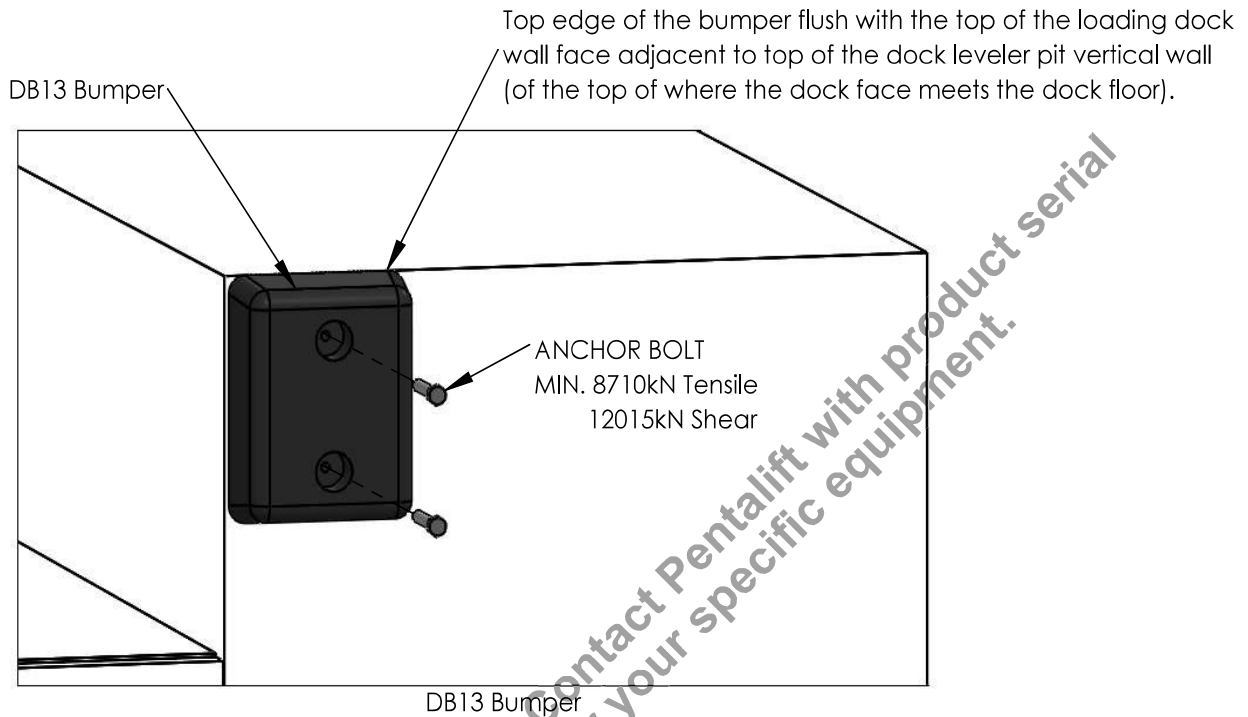

M056AB

Figure 38: DB13 Installation

Bumper Angle Flat-bar Typical Installation

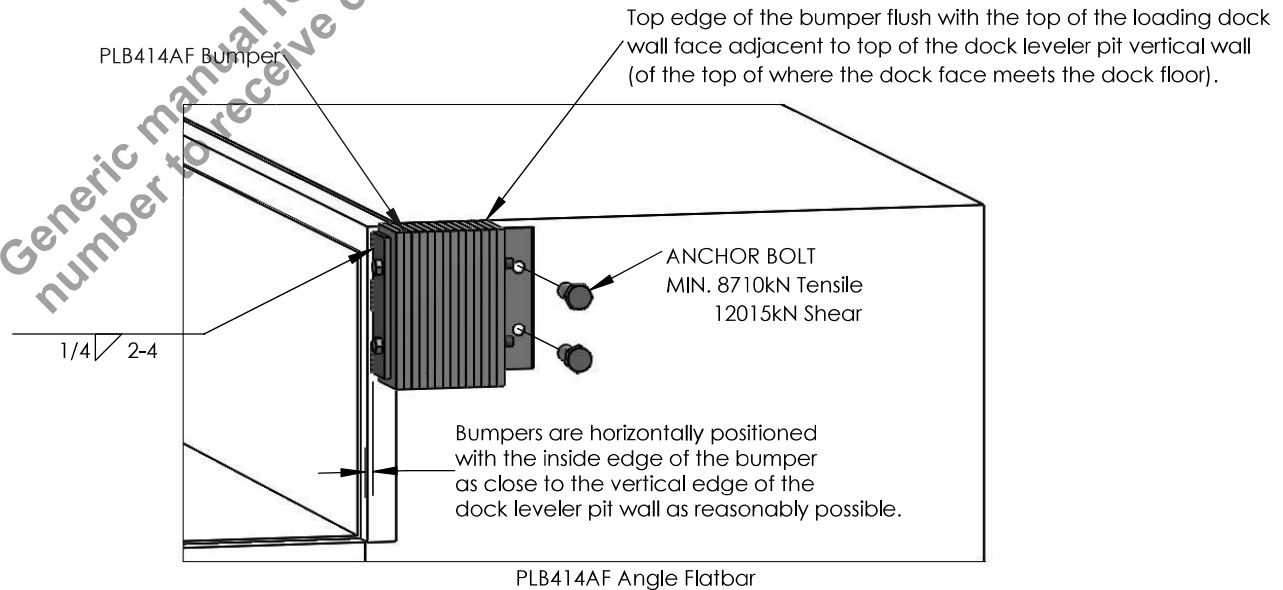

M056AC

Figure 39: PLB414AF Installation

Bumper Angle Angle Typical Installation

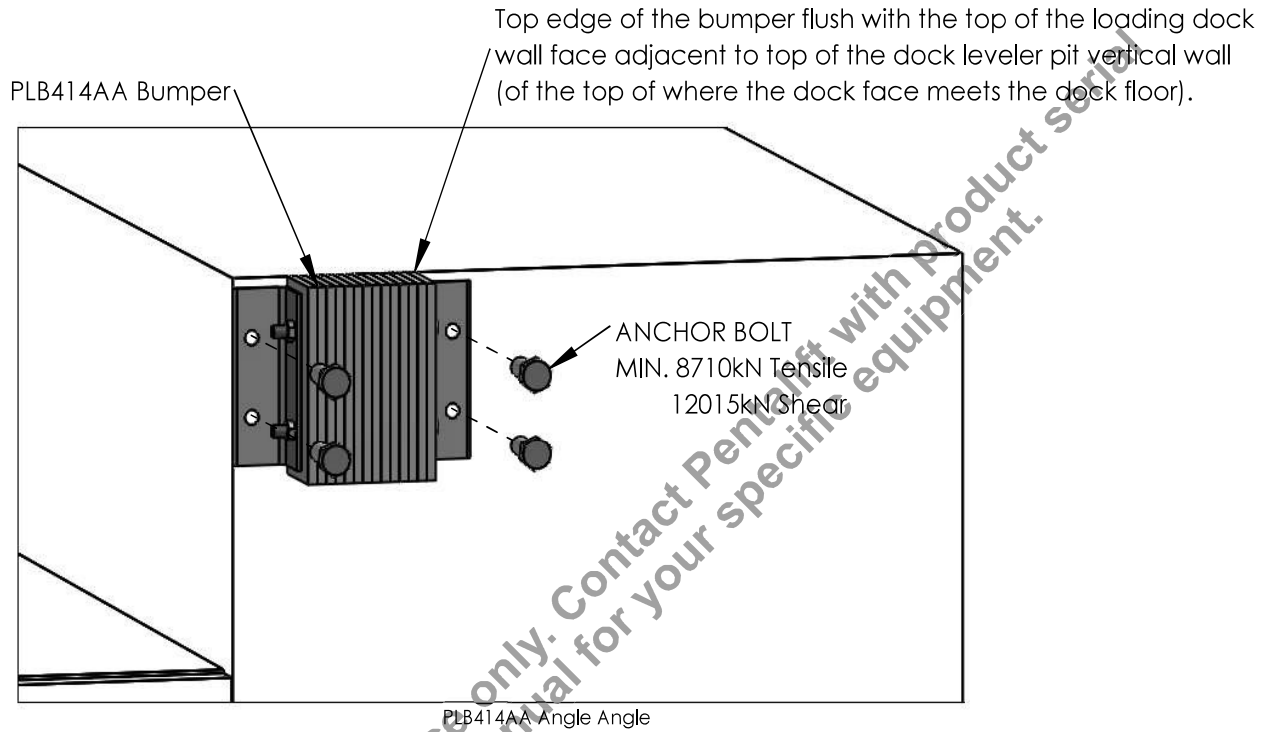

M056AD

Figure 40: PLB414AA Installation

BREAK-IN AND PERFORMANCE CHECK



BEFORE DOING ANY INSTALLATION, MAINTENANCE INSPECTION OR TROUBLE SHOOTING, BARRICADE ALL AREAS FROM TRAFFIC AROUND THE WORK AREA INSIDE (AND OUTSIDE IF APPLICABLE) FOR SAFETY AND POST APPROPRIATE WARNING SIGNS.

NOTE: IN SOME CASES THERE IS A CONSIDERABLE AMOUNT OF TIME BETWEEN THE SHIPMENT DATE AND USE OF YOUR DOCK LEVELER. THIS INITIAL BREAK-IN AND PERFORMANCE CHECK SHOULD BE PERFORMED BEFORE YOU BEGIN REGULAR USE OF YOUR DOCK LEVELER TO ENSURE THAT IT IS OPERATING PROPERLY.

NOTE: Read the SAFETY INFORMATION AND WARNINGS before operating the dock leveler. (See page iii)

1. Confirm that lip hinge assembly is free from debris and obstructions. Concrete, stucco, parging materials, nails, screws, pieces of wood from pallets and skids and other debris can be present at the hinge assembly. Any debris of this nature can inhibit the proper operation by creating additional friction or impediments to the lips rotational engagement. Debris of this nature should be removed on a regular ongoing basis. The user of the equipment should be made aware of this concern and the need to clean and maintain this aspect of the dock leveler on a regular basis.



ALWAYS ENSURE NO ONE IS WITHIN 6 FEET OF THE FRONT (LIP END) OF THE DOCK LEVELER PRIOR TO ACTIVATION. THE HINGED LIP WILL EXTEND RAPIDLY AND LOCK INTO ITS WORKING POSITION DURING UPWARD MOVEMENT OF THE DECK. STAY CLEAR OF DOCK LEVELER WHEN IT IS MOVING.

2. Make sure the dock leveler lip hinge assembly is properly lubricated in accordance with the owner's manual instructions (see "INSTALLATION, INSPECTION, MAINTENANCE AND LUBRICATION" on page 45).
3. Cycle the dock leveler by fully pulling and holding the release ring on the dock leveler. Confirm the dock leveler lip extends and locks into a fully extended position. If the dock leveler lip does not lock in an extended position then install the maintenance stand (see "SUPPORTING THE LEVELER FOR MAINTENANCE" on page 40) and move to step 6.
4. If the lip locks in an extended position then move to step 5.
5. With the deck raised, begin "walking" the dock leveler down until it bottoms out on the deck stops. **NEVER WALK ON THE LIP TO LOWER THE DOCK LEVELER.** (See Figure 41: Walk Down the Deck on page 32). If the dock leveler walks down with an acceptable lowering force, then the complete step 7.
6. **Do not** start by adding spring tension onto the dock leveler lift springs. This is by far the most common first step mistake that is made when addressing mechanical dock leveler issues. Adding lift spring tension at too high a level can be the source of other issues, including and not limited to:
 - a. Dock leveler deck twist when the dock leveler is in the parked position,
 - b. The hold down assembly not properly holding the dock leveler down. For example, the dock leveler floats up when parked or during use.
 - c. Too high of a walk down force or weight required to lower the dock leveler.
7. Make sure the other areas of the dock leveler are properly lubricated in accordance with the owner's manual instructions (see "MAINTENANCE AND LUBRICATION" on page 45).
8. Make sure the dock leveler lip assist spring adjustment is set at the correct level as per the instructions on (see "LIP ASSIST SPRING ADJUSTMENT" on page 52). This is a vital adjustment. Proper adjustment of the lip assist spring will allow the lift spring adjustment to be minimized and avert the issues listed item 5 above.
9. After confirming the lip assist spring adjustment is correct. Remove the maintenance stand.

10. If the maintenance stand has not released the lip then release the lip from its locked (extended) position by using the following set of steps.
 - a. Stand facing the lip end of the dock leveler and firmly grasp the lip with both hands (wear gloves).
(See Figure 41: Lift Until Liplock Releases 32 on page 62)
 - b. Lift the lip upwards until you feel the lip lock mechanism release.
 - c. Once the lip lock releases continue to bear the weight of the lip.
 - d. If the weight is excessive with the lip at 45 degrees (greater than approximately 15 to 20 lbs.) then adjust the lip assist spring tension as per (reference lip assist spring adjustment).
 - e. After lip spring adjust is completed, cycle the dock leveler again and confirm operation takes place. (See "Figure 42: Lower Until Vertical" on page 32). Again test the lip weight at 45 degrees is approximately 15 to 20 lbs. If it is then go to step 11. If not continue to add more tension to the lip assist spring until the approximately 15 to 20 lbs. weight is achieved.
11. Return the dock leveler to the parked position and cycle the dock leveler again. If the dock leveler deck assembly walks down with an acceptable weight then the adjustment and set up is complete. If not reduce lift spring tension by turning the lift spring tension nut counter clockwise 2 turns at a time. There is a balance that must be maintained between sufficient lift spring tension to lift the deck assembly and extend the lip versus the walk down force required to lower the leveler to the truck or to park it. Confirm that the dock leveler lift spring tension is properly set. The tension should be sufficient to extend the lip but with not too heavy a walk down force. If the lip is extending experiment with the lift spring tension by reducing the tension until activating the dock leveler by firmly pulling and holding the release chain to it's full extent. If the lip continues to extend and lock the lift spring tension is sufficient. If the lip does not extend and lock more lift spring tension maybe required. If the dock is too heavy to walk down adjust to less lift spring tension.
12. To return the dock leveler to its stored position, pull the release ring by jogging it up and down until the leveler raises slightly and the lip clears the front frame of the dock leveler. Then "walk" the dock leveler into its stored position.

NOTICE

As the performance test is being conducted, watch closely for any signs that the dock leveler might not be operating properly. If you are in doubt, refer to Operating Instructions on page 33 and Trouble Shooting Guide on page 58 or contact your Pentalift representative.

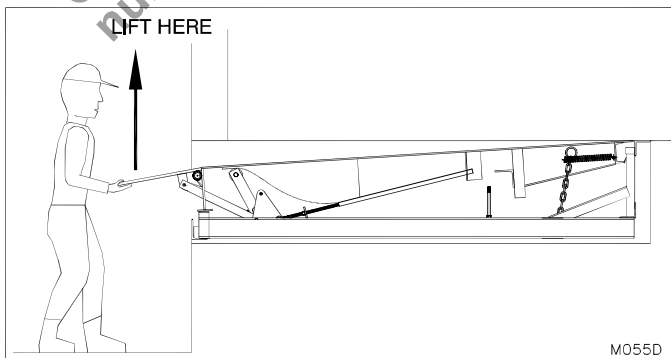

Figure 41: Lift Until Liplock Releases

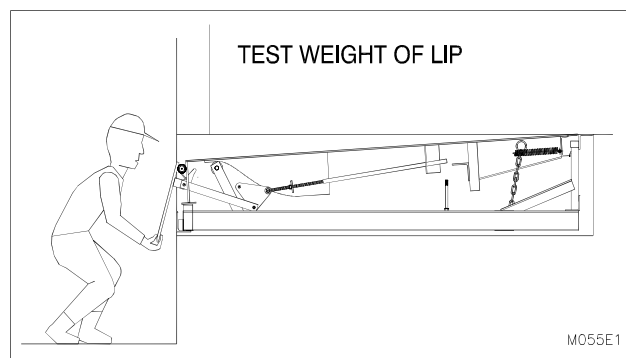

Figure 42: Lower Until Vertical

OPERATING INSTRUCTIONS

Note On Capacity: The dock leveler capacity indicated on the serial plate must be divided with a factor to accommodate dynamic loading factors. For more information see Pentalift document - Dock Leveler Capacity – Understanding Loading Dock Capacity at <http://www.pentalift.com/dock-leveler-capacity.php>

Note regarding above and above level ranges of dock levelers relative to dock leveler deck length :

This dock leveler is designed to accommodate truck and trailer beds that arrive at the facility with heights that are different than the dock height of the facility. The dock leveler deck assembly pivots and rests at angle to accommodate the variance in the truck or trailer bed height. In doing this dock leveler accommodates truck and trailer beds that are both above and below the loading dock floor height.

It is important to manage the extent of this compensation for the difference to a reasonable and desirable level. Factors that determine reasonable and desirable levels include but are not limited to the following:

- The length of the dock leveler deck assembly. The longer the dock leveler deck assembly is the better it will be for accommodating dimensional differences in the truck / trailer bed heights relative to the load dock height. For example, all other conditions being equal, an 8ft long dock leveler deck assembly accommodates a greater height differences than 6ft long dock leveler deck assembly. The longer deck assembly simply reduces the angle of incline that the loading / unloading equipment (IE fork lift or pump truck) have to drive up and down as they go in and out of the truck / trailer.
- The type of loading / unloading equipment being used at the loading dock. For example a gas powered fork lift truck will generally have more power and larger wheels to accommodate larger angles of incline than an electrically powered pallet truck or a manually pushed pallet truck or cart.
- For obvious reasons, larger inclines create more wear and tear on equipment that is powered driven and has brakes.
- Larger inclines can result impact loads applied to the dock leveler as the fork lift hits the inclined dock leveler assembly and this can overload the leveler and result in damage to the dock leveler.
- Large inclines can create safety concerns due to possible run away loads. This is particularly true for manually propelled pump trucks or carts. As well, large inclines can make it onerous to push the same equipment up the inclines.
- Consideration of these factors should be made at the time the loading dock is designed.
- These factors should also be considered whenever changes to the factors listed above change at the loading dock.



USE BY UNTRAINED PEOPLE CAN RESULT IN PROPERTY DAMAGE, BODILY INJURY OR DEATH. READ, KNOW, AND OBEY ALL OPERATING INSTRUCTIONS AND SAFETY INFORMATION. FOLLOW ALL OSHA REGULATIONS REGARDING THE USE OF THIS EQUIPMENT. DO NOT USE THE DOCK LEVELER IF ANY PART OF IT LOOKS BROKEN OR IF IT DOES NOT SEEM TO OPERATE PROPERLY. IF REPAIRS ARE NEEDED, CONTACT YOUR PENTALIFT REPRESENTATIVE.



TO AVOID POSSIBLE PERSONNEL INJURY AS WELL AS, TO AVOID DAMAGE TO THE DOCK LEVELER AND /OR THE PRODUCT, DO NOT DRAG OR SLIDE ANYTHING ACROSS THE SURFACE OF THE DOCK LEVELER. ALWAYS ENSURE THE FORKLIFT FORKS ARE RAISED TO CLEAR THE DOCK LEVELER SURFACE AND THE DOCK LEVELER COMPONENTS.

NOTE: Read the SAFETY INFORMATION AND WARNINGS before operating the dock leveler. (See page iii)

NOTE: Always be certain that the truck/trailer is parked tight against the face of both dock bumpers and that the truck is locked in place by a vehicle restraint and/or that the truck wheels are chocked (See “Figure 44: Walk Down the Deck” on page 35) before loading or unloading. All ‘air ride’ trailers must release the air from the suspension mechanism prior to activating the dock leveler for use.

1. Load or unload END LOADS with the deck and lip in the stored position as shown in “Figure 49: End Loading/ Unloading” on page 39. (See “END LOADING/ UNLOADING INSTRUCTIONS” on page 39 and “END LOADING BELOW LEVEL CONTROL OPERATION” on page 39)

⚠ DANGER ALWAYS ASSURE NO ONE IS WITHIN 6 FEET OF THE FRONT (LIP END) OF THE DOCK LEVELER PRIOR TO ACTIVATION. THE HINGED LIP WILL EXTEND RAPIDLY AND LOCK INTO ITS WORKING POSITION DURING UPWARD MOVEMENT OF THE DECK. STAY CLEAR OF OPERATING PATH AT ALL TIMES.

2. After end loading, operate the dock leveler by pulling the release chain to its full extension and HOLDING until the deck’s movement stops; then let go of the release chain and let it fall back into the pocket.

⚠ DANGER NEVER WALK ON THE LIP TO LOWER THE DOCK LEVELER ONTO A TRUCK BED. (SEE “Figure 44: Walk Down the Deck” on page 35) FAILURE TO ENSURE THE LIP CONTACTS THE TRUCK BED MAY RESULT IN DAMAGE TO THE DOCK LEVELER AND/OR THE TRUCK. NEVER USE ANYTHING OTHER THAN THE OPERATOR’S WEIGHT TO LOWER THE DECK FROM THE RAISED POSITION.

3. Walk out onto the front edge of the deck, lowering it until the lip rests firmly on the truck bed with at least 4” of penetration. (See “Figure 45: 4” Penetration” on page 35)

On dock levelers equipped with mechanical Fallsafe, and if the truck is below dock level, pull and hold the Below Level Control Activator (See “Figure 47: Below Level Control Operation” on page 38) as you move out on the deck lowering it until the lip makes firm contact with the truck bed.

Note: The lip must extend a minimum of 4” onto the truck bed. (See “Figure 45: 4” Penetration” on page 35)

4. Complete loading or unloading.

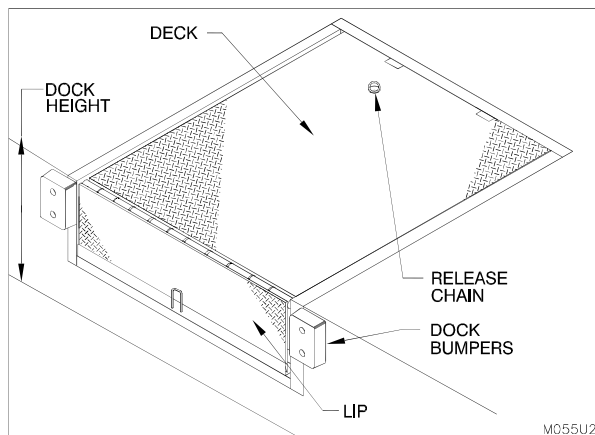

Figure 43: Deck in Stored Position

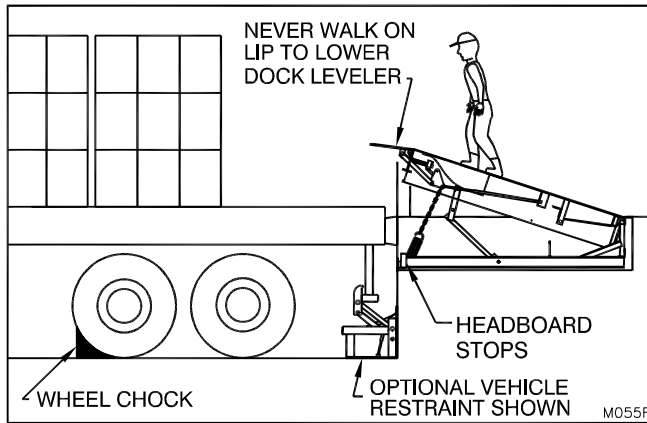

Figure 44: Walk Down the Deck

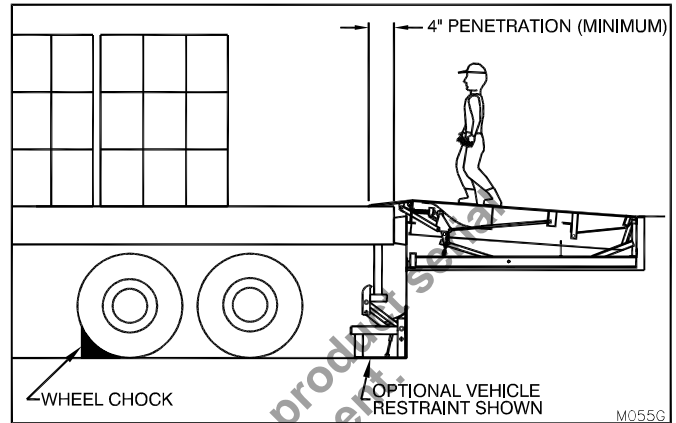

Figure 45: 4" Penetration

5. **NOTE: On dock levelers equipped with Mechanical Fallsafe, the below dock movement is limited by below level leg supports. As the truck and suspension are compressed during the loading or unloading operation, it may be necessary to readjust the support leg setting so the lip is always fully extended and in firm contact with the truck bed. To lower the deck to the next lower setting, pull and hold the Below Level Control Activator as you move toward the front of the deck. (See "Figure 47: Below Level Control Operation" on page 38) Never attempt to adjust the below level position while a load is on the deck.**
6. When loading or unloading is complete, or to handle end loads, operate the dock leveler by jogging the release chain until the lip clears the truck bed and falls to the pendant position. (Jogging the release chain reduces the momentum of the rising deck thus lessening the shock impact on the hold down) Release the chain and walk the deck down to the stored position, assuring that the lip is behind the front angle. (See "Figure 48: Lip Keeper" on page 38)
7. Once loading and/or unloading is complete, remove wheel chocks or disengage the vehicle restraint. The truck may now leave the dock.

NOTE: If the truck being loaded or unloaded is below dock level, see End Loading Below Level Control Operation.

NOTE: In the event that the truck departs prior to the dock leveler being stored, one of the following methods are to be used to store the dock leveler:

- If the deck was 4" or more above dock level when the truck departed, the lip will fall to the pendant position. Walk the dock leveler down to its stored position assuring that the lip is behind the front angle. (See "Figure 48: Lip Keeper" on page 38)
- If the deck was less than 4" above dock level, the lip will fall to the pendant position in front of the front angle. To store the dock, jog the release chain and allow the dock leveler to rise a minimum of 4" above dock level to ensure the lip will clear the front angle. Walk the dock leveler down to its stored position, assuring that the lip is behind the front angle. (See "Figure 48: Lip Keeper" on page 38).

HYDRAULIC CONVERSION KIT - FOR CURRENT MECHANICAL DOCK LEVELER OWNER

Note: This dock leveler is easy to convert from the existing manual mechanical operation to hydraulic – push button operation by utilizing Pentalift's MDHCK conversion kit. The conversion will provide the following benefits:

Ergonomics: Converting the dock leveler to push button operation from manual release chain operation improves ergonomics. Operators are not put at risk from bending and pulling the manual release chain. As well, concerns with the limitations of lighter operator's ability to walk down the mechanical dock leveler are eliminated.

Safety: Push button operation simplifies and assists operator control, thereby increasing safety. Dock leveler can be interlocked with a new vehicle restraint, overhead door and other equipment.

Hydraulic Operation: Both the deck assembly and the lip operator are activated by the hydraulic cylinder.

Reliability: Elimination of mechanical components such as hold-downs and the lifting spring mechanisms reduces breakdowns and down time and maintenance costs.

Push Button Operation: NEMA 12, wall mounted push button facilitates simple and efficient operation of the dock leveler.

Maintenance & Operating Cost: Costs are significantly lowered or eliminated through hydraulic conversion.

Reduced Noise Levels: Smoother hydraulic operation reduces operating noise levels.

For more information go to www.pentalift.com and search MDHCK conversion kit. For installation pricing contact your Pentalift representative.

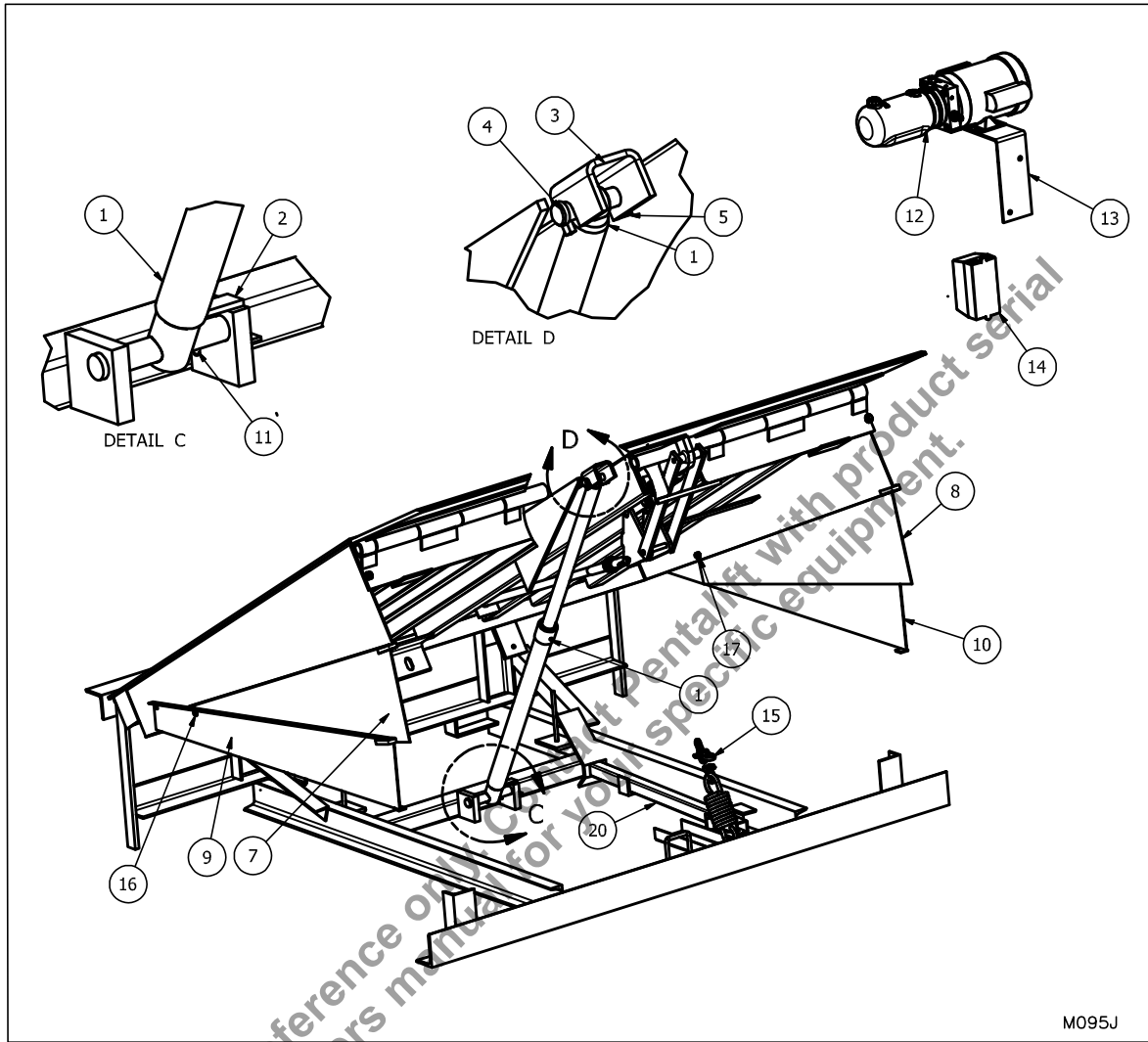

Figure 46: Hydraulic Conversion Kit

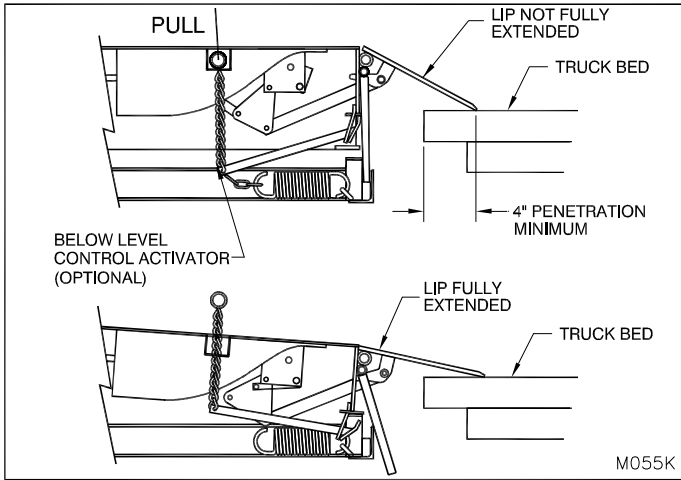

Figure 47: Below Level Control Operation

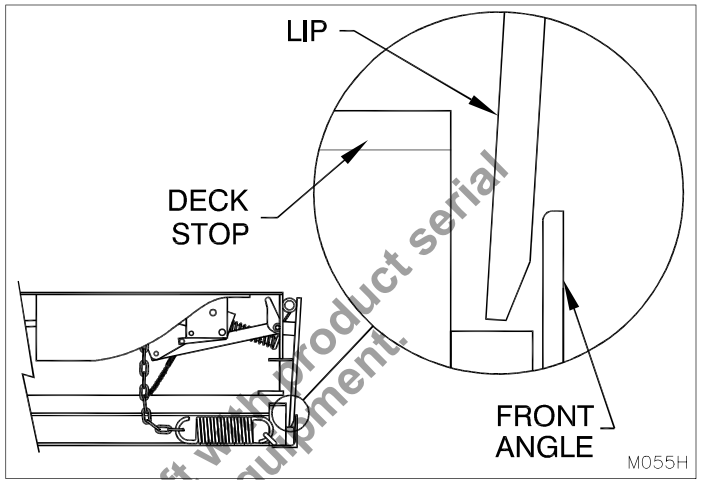

Figure 48: Lip Keeper

Generic manual for reference only. Contact Pentalift with product serial number to receive owners manual for your specific equipment.

END LOADING/ UNLOADING INSTRUCTIONS



WHEN THE CARGO AT THE REAR OF THE TRUCK DOES NOT ALLOW THE LIP TO

FULLY EXTEND AND REST FIRMLY ON THE TRUCK BED AS OUTLINED UNDER THE OPERATING INSTRUCTIONS (SEE page 33), THEN THE END LOADING/ UNLOADING PROCEDURES MUST BE USED AS OUTLINED UNDER THE OPERATING INSTRUCTIONS.

DURING END LOADING/ UNLOADING THERE WILL BE A GAP PRESENT BETWEEN THE DOCK LEVELER AND THE TRUCK BED. ENSURE THAT THE FRONT WHEELS OF THE FORK TRUCK NEVER FALL INTO THE GAP BETWEEN THE DOCK LEVELER AND THE TRUCK.

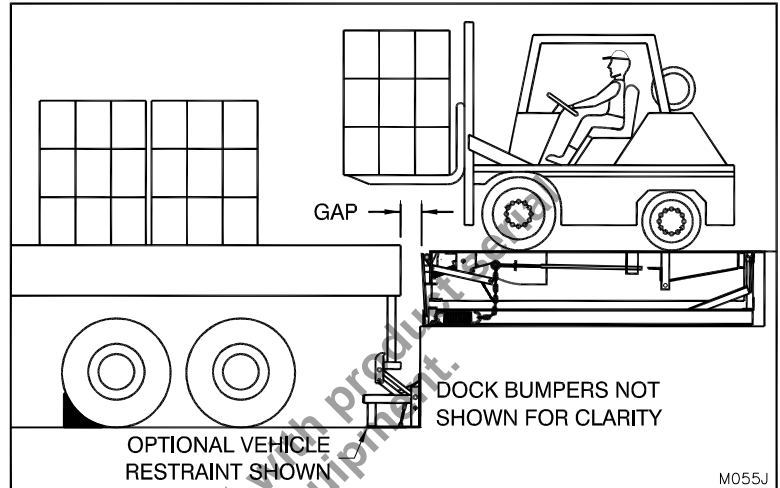

Figure 49: End Loading/ Unloading

WHEN UNLOADING, IMMEDIATELY AFTER THE END LOADS ARE REMOVED, THE DOCK LEVELER IS TO BE USED WITH THE LIP EXTENDED AS INDICATED UNDER THE OPERATING INSTRUCTIONS.

END LOADING BELOW LEVEL CONTROL OPERATION

To lower the dock leveler for end loading, without extending the lip:

1. Jog the release chain and allow the dock leveler to raise a minimum of 4" above dock level. Release the chain before the dock reaches its fully raised position.
2. Pull the optional Below Level Control activator. Walk forward on the dock leveler while continuing to pull the handle until your weight forces the dock leveler to lower to the fully below dock level position. (See "Figure 50: Below Level End Loads" on page 39)
3. Load or unload end loads.
4. To return the dock leveler to the stored position: Repeat #1 above and walk the dock leveler into its stored position, assuring the lip is behind the front angle. (See "Figure 48: Lip Keeper" on page 38)

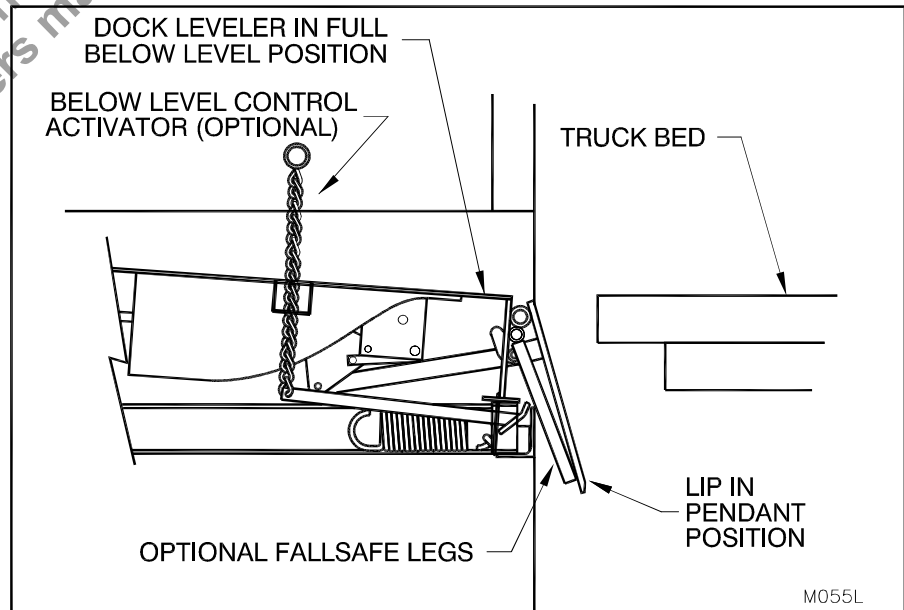

Figure 50: Below Level End Loads

SUPPORTING THE LEVELER FOR MAINTENANCE



ONLY TRAINED AND QUALIFIED PERSONNEL ARE TO PERFORM INSPECTION OR MAINTENANCE AND SERVICE PROCEDURES.



BEFORE DOING ANY INSTALLATION, MAINTENANCE, INSPECTION OR TROUBLE SHOOTING, BARRICADE ALL AREAS FROM TRAFFIC AROUND THE WORK AREA INSIDE (AND OUTSIDE IF APPLICABLE) FOR SAFETY AND POST APPROPRIATE WARNING SIGNS. NEVER GO BENEATH THE DOCK LEVELER FOR ANY REASON UNLESS THE LIP AND DECK ARE PROPERLY SUPPORTED BY THE MAINTENANCE STAND (SEE “SUPPORTING THE LEVELER FOR MAINTENANCE” on page 40). IT IS THE RESPONSIBILITY OF THE OWNER TO ENSURE THAT NO LOAD OR TRAFFIC IS PLACED ON THE DECK WHILE THE MAINTENANCE STAND IS IN USE. THE CONSTRUCTION OF THE MAINTENANCE STAND IS INTENDED TO SUPPORT THE WEIGHT OF THE UNLOADED DOCK LEVELER ONLY.



THE BLOCKING PROCEDURES DESCRIBED BELOW ARE SUITABLE ONLY FOR THE INSPECTION, TROUBLE SHOOTING AND MAINTENANCE PROCEDURES DESCRIBED IN THIS MANUAL. THEY MAY NOT BE SAFE FOR OTHER INSPECTION, MAINTENANCE AND REPAIR PROCEDURES THAT MAY BE REQUIRED. CONTACT YOUR AUTHORIZED PENTALIFT REPRESENTATIVE FOR DIRECTION PRIOR TO UNDERTAKING ANY ACTIONS OTHER THAN THOSE DESCRIBED IN THIS MANUAL. FAILURE TO PROPERLY ADHERE TO DECK BLOCKING PROCEDURES IS TO RISK THE SUDDEN AND UNCONTROLLED DESCENT OF THE DECK DURING MAINTENANCE OR INSPECTION. A FALLING DECK CAN CAUSE SEVERE INJURY OR DEATH. IF OTHER TYPES OF REPAIRS ARE REQUIRED, THEN A PENTALIFT AUXILIARY MAINTENANCE STAND IS TO BE UTILIZED. SEE PAGE 43 FOR MORE INFORMATION ON HOW IT IS USED. THE AUXILIARY MAINTENANCE STAND IS AVAILABLE THROUGH THE PENTALIFT PARTS DEPARTMENT. IT IS PENTALIFT PART NUMBER 5000264.



The maintenance stand of this dock leveler is designed for use only when the dock leveler is securely welded into the dock leveler pit. Use of the stand is not recommended if the dock leveler is not securely welded into the pit (see “Figure 8: Weld to Rear Curb Angle” on page 8). To support the dock leveler at times when installation welding is not in place, utilize the auxiliary maintenance stand that supports the dock leveler more centered on the dock leveler width.



THE RATCHET HOLD DOWN CONTAINS A COMPRESSED SPRING WHICH WILL EJECT FROM THE TUBE IF OPENED AND COULD CAUSE SERIOUS INJURY OR DEATH. DO NOT TRY TO OPEN, TAKE APART OR TAMPER WITH THE TUBE. IF THIS PART IS DAMAGED, REMOVE AND REPLACE.

When performing any maintenance, adjustments or troubleshooting on the dock leveler, always use the maintenance stand to support the leveler before going beneath the deck (See “SUPPORTING THE LEVELER FOR MAINTENANCE” on page 41).

For Dock Leveler Without Mechanical Fallsafe

1. Raise the deck to its maximum raised height and fully extend the lip.
2. Lift the maintenance stand out of the cradles and place on the front angle in a position so that it will not interfere with a deck beam.
3. Carefully walk the deck down until the headboard makes contact with the maintenance stand. If the deck and lip did not properly position, raise the deck and reposition the maintenance stand. (See Figure 51: Supporting the Dock Leveler for Maintenance on page 41)

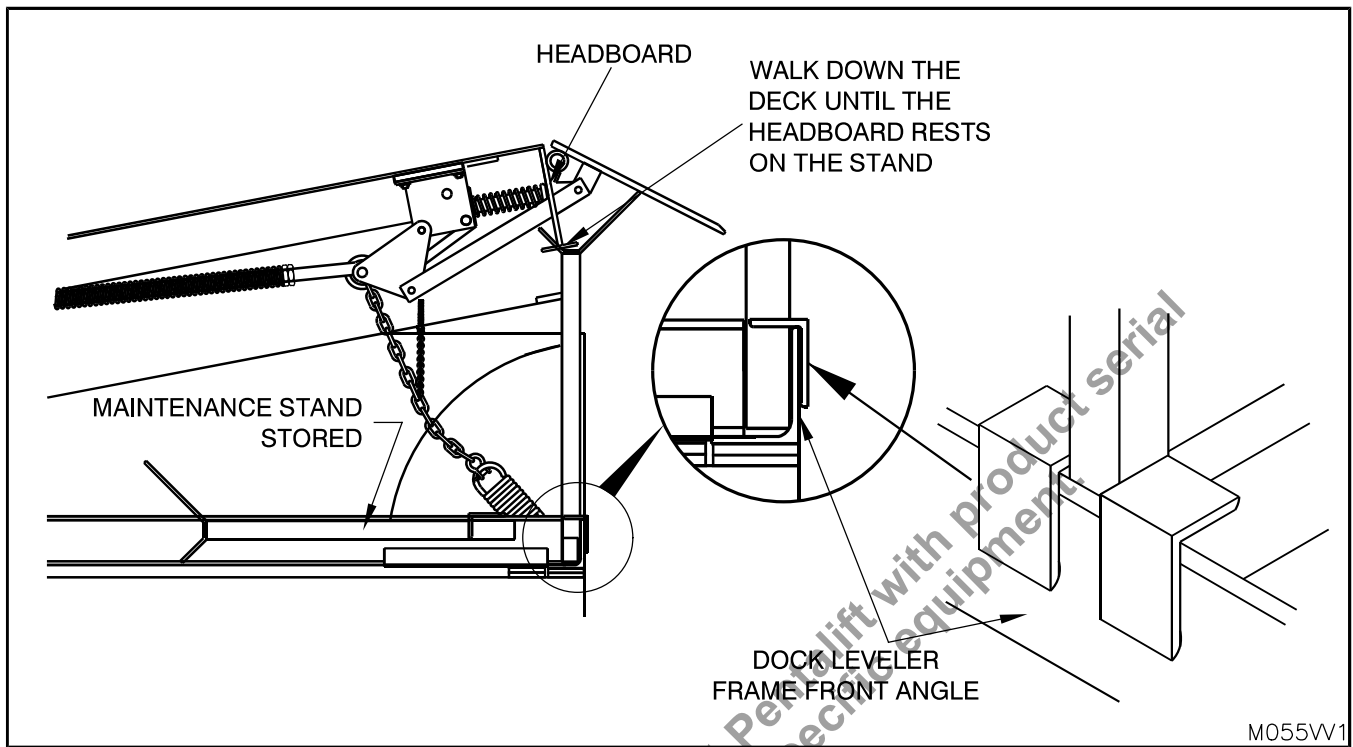

Figure 51: Supporting the Dock Leveler for Maintenance



NEVER WALK ON THE LIP TO LOWER THE DOCK LEVELER. (SEE “Figure 44: Walk Down the Deck” on page 35)

Also follow all safe working procedures and the “SAFETY INFORMATION AND WARNINGS” on page II.

For Dock Levelers with Mechanical Fallsafe Option

1. Raise the deck to its maximum raised height and fully extend the lip.
2. Lift the maintenance stand out of the cradles and place on the front angle in a position so that it will not interfere with a deck beam.
3. While holding the maintenance stand, pull down on the lip while guiding the front tang of the stand between the headboard and mechanical fallsafe crossbar (See “Figure 52: Supporting the Dock Leveler with Mechanical Fallsafe” on page 43).

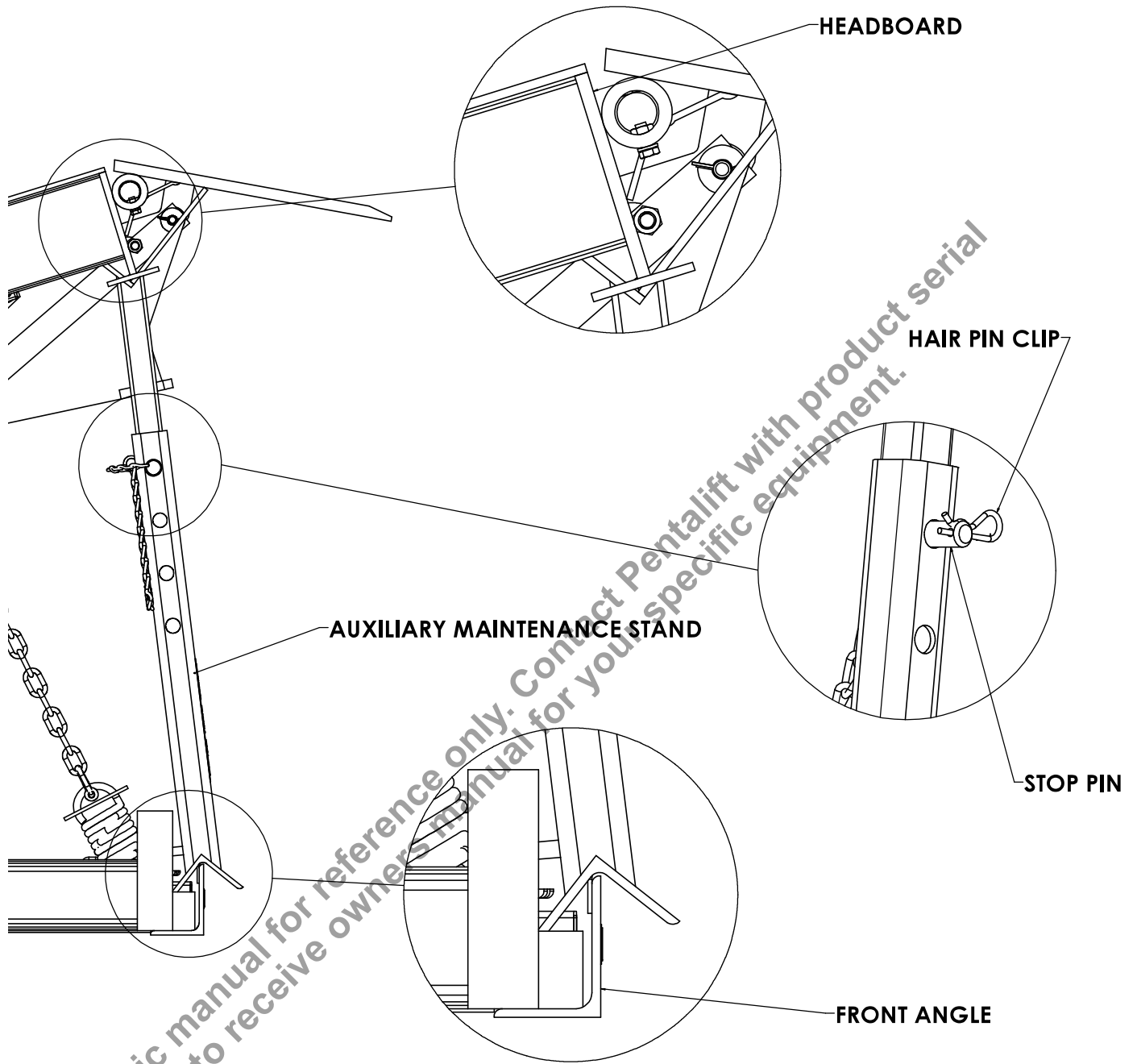

M0083J

Figure 51.1: Supporting the Dock Leveler with the Auxiliary Maintenance Stand

Pentalift auxiliary maintenance stand

The auxiliary maintenance stand is available through the Pentalift part department. It is Pentalift part number 5000264. The Pentalift auxiliary maintenance stand is to be used whenever there are repairs or maintenance requirements of a more involved or substantial nature. Figure 51.1 on page 42 shows the stand. The stand is telescopic and facilitates its extension or retraction to match the required length for various models of dock leveler. The stand should be used by first engaging the integrated maintenance stand of the dock leveler as described in this manual. Then engage the auxiliary stand by locating the bottom end of the angle bracket on a substantial portion of the lower dock leveler frame. The upper angle bracket is then extended to capture a portion of the dock leveler headboard. The stop pin is utilized to lock the stand in one of the selectable extended positions. Retain the stop pin with the attached hair pin clip. Always make sure the maintenance stands are properly engaged prior to commencing repairs or going into the operating path of the dock leveler. If you are not confident regarding the proper application of the stands do not commence work or go beneath the deck. Figure 51.1 on page 42 shows the proper use and location of the stand.

Note: In some instances it may be best to utilize two auxiliary maintenance stands to support the dock leveler. The two maintenance stands can be spaced equally over the width of the dock leveler.

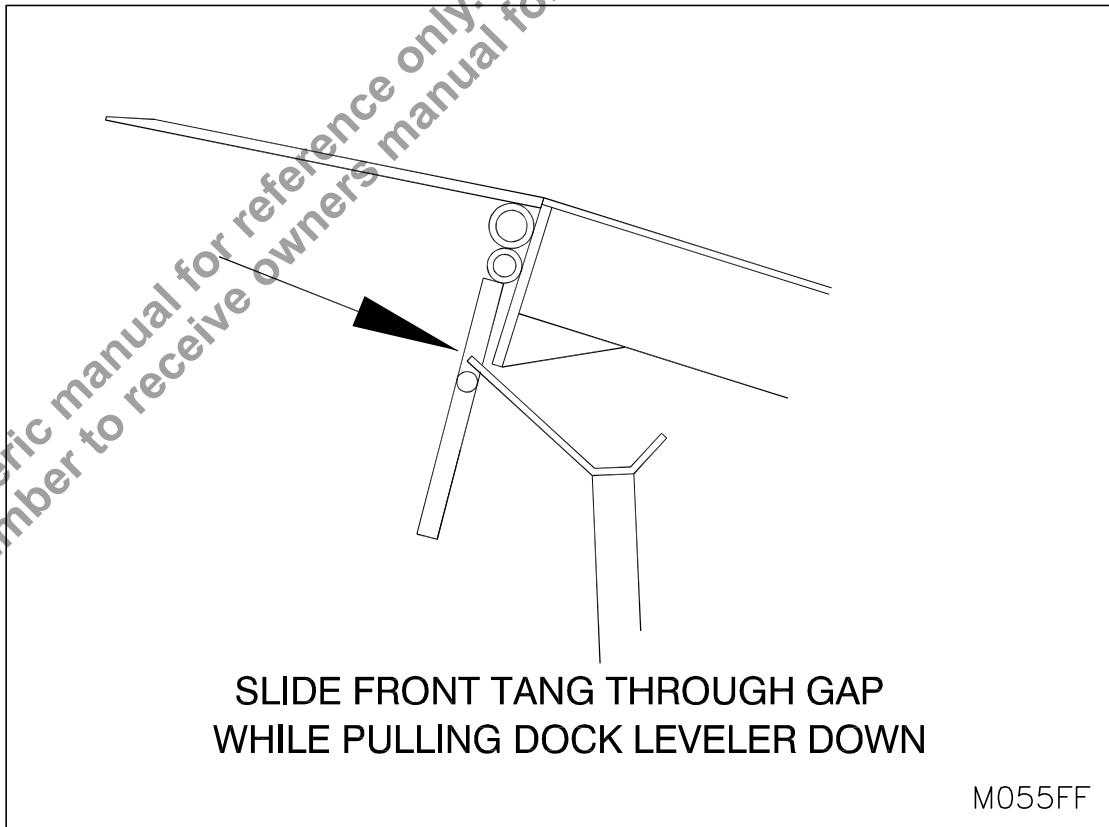

Figure 52: Supporting the Dock Leveler with Mechanical Fallsafe

ADJUSTABLE LIP STOP

The lip stop for all capacities 30,000 through 50,000 lbs is adjustable. The lip stop stops the lip in the correct location when moving the dock leveler into the stored position. The threaded adjustment mechanism consists of a 5/8-11 bolt mounted through the headboard along with two 5/8-11 adjustment nuts.

NOTE: Proper adjustment is made at the factory and typically won't require further adjustment. Do not attempt any adjustments unless you are confident that adjustment is required.

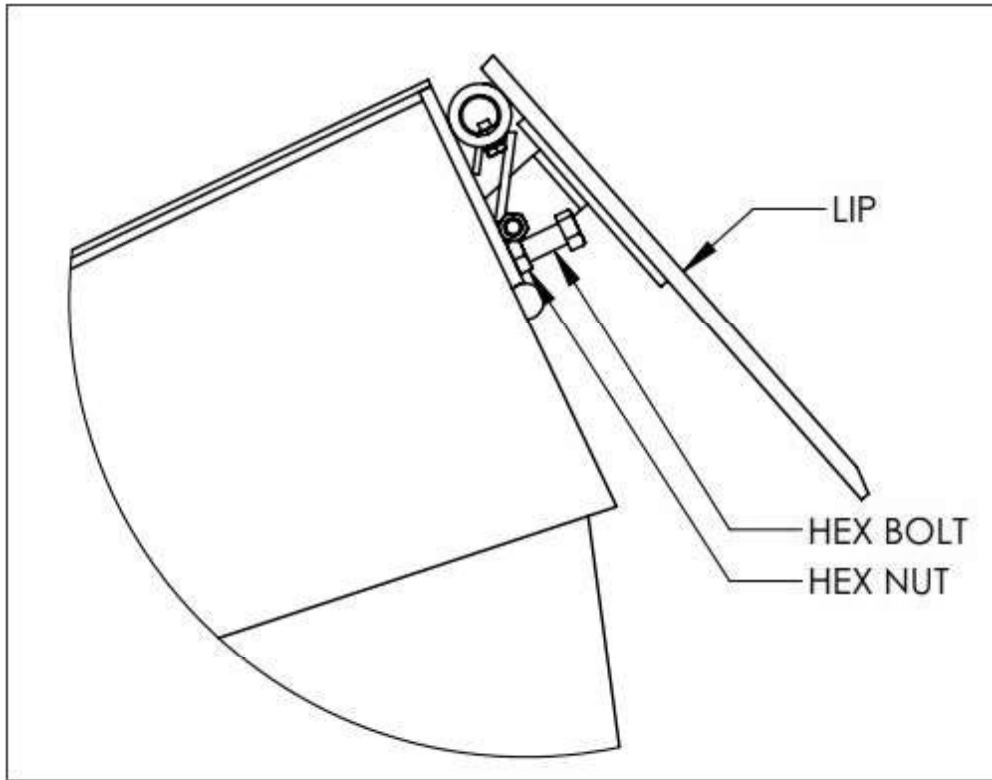

Figure 63: Adjustable Lip Stop

INSTALLATION, INSPECTION, MAINTENANCE AND LUBRICATION

UNLESS OTHERWISE NOTED, THE FOLLOWING MAINTENANCE AND INSPECTION PROCEDURES SHOULD BE CONDUCTED AT A MINIMUM OF EVERY 30 DAYS. INCREASE FREQUENCY FOR MORE SEVERE ENVIRONMENTS.



Importance of following installation instructions: A very high level of field issues with this type of equipment can be directly attributed to improper or incomplete installation. The installation instruction and information provided for this equipment is thorough. A step by step sequence for installation is provided. All steps must be followed and completed to provide a complete installation. Incomplete or improper installations can lead to equipment malfunction and / or damage, create safety issues and void warranties. Please follow all installation and set ups steps as indicated in the installation instructions and owner's manual. If you are unclear or uncertain regarding any of the steps contact your Pentlift representative for clarification. A copy of the completed steps listing with the sign off and photos of the installation as indicated at the conclusion of the installation instructions will be required prior to any Pentlift factory trouble shooting assistance.



Importance of inspection, monitoring and correcting structural damage: The deck, lip and frame assemblies of the dock leveler are structurally subjected to loads on going. It is important to regularly visually inspect the dock levelers structurally for signs of damage or wear. Damage could be in the form of distorted, cracked or broken structural members or welds. Areas to review include but are not limited to; lip and headboards tubes, deck beam adhesion to the head board, deck plate and tail board and rear frame attachment to rear curb angle. Any damage or signs of cracking, etc. should be noted and addressed immediately. Immediate attention and action to address issues of this nature generally results in simple repairs. Issues that are left unchecked and / or unaddressed result in significant repairs and even entire replacement as well as a serious critical failure resulting in serious injury or death. If structural issues are detected us of the equipment is to discontinued until the appropriate corrections or alterations are made. Continued use will result in further damage and potentially dangerous equipment failure.

NOTE: The frequency of reviews should be a maximum of every 30 days. The frequency should be increased for higher frequency and use applications i.e. multiple shifts or high traffic loading docks. For assistance and guidance in evaluating and correcting structural damage contact your Pentlift representative.



ONLY TRAINED AND QUALIFIED PERSONNEL ARE TO PERFORM INSPECTION OR MAINTENANCE AND SERVICE PROCEDURES.



BEFORE DOING ANY INSTALLATION, MAINTENANCE, INSPECTION OR TROUBLE SHOOTING, BARRICADE ALL AREAS FROM TRAFFIC AROUND THE WORK AREA INSIDE (AND OUTSIDE IF APPLICABLE) FOR SAFETY AND POST APPROPRIATE WARNING SIGNS. NEVER GO BENEATH THE DOCK LEVELER FOR ANY REASON UNLESS THE LIP AND DECK ARE PROPERLY SUPPORTED BY THE MAINTENANCE STAND (SEE "SUPPORTING THE LEVELER FOR MAINTENANCE" on page 40). IT IS THE RESPONSIBILITY OF THE OWNER TO ENSURE THAT NO LOAD OR TRAFFIC IS PLACED ON THE DECK WHILE THE MAINTENANCE STAND IS IN USE. THE CONSTRUCTION OF THE MAINTENANCE STAND IS INTENDED TO SUPPORT THE WEIGHT OF THE UNLOADED DOCK LEVELER ONLY.

On an ongoing basis perform the following:

- Read the **SAFETY INFORMATION AND WARNINGS** before servicing the dock leveler. (See page II.)
- Remove all debris from the dock leveler and pit area. Make sure that all lip hinges are free from debris.
- It is the owner's responsibility to assure that all labeling remains legible and in its original position throughout the life of the product. (See Figure 1: Precautionary Labels on page 2)
- Inspect equipment for protective coatings (i.e. paint) that has deteriorated or been removed. Prepare affected area and reapply protective coating as required.
- Inspect the equipment for structural damage as detailed on page 45.
- Inspect equipment for loose bolts, missing cotter pins or spring pins. If any are found, replace missing cotter pins or spring pins and/or retighten loose bolts.
- At every maintenance interval, inspect the dock leveler for any damaged or worn parts. If any damaged or worn parts are found, discontinue use of the dock leveler and/or repair immediately. If the dock is equipped with Mechanical Fall Safe, check to ensure the spring bar is not bent or removed. (See spring bar on "Figure 62: Optional Fallsafe Replacement Parts" on page 62)

Inspect the lifting arm and the lifting arm roller's physical relationship with the cam. Confirm the lifting arm roller is running predominately in the center of the cam. If the lifting arm roller is not running predominately in the center of the cam determine the reason and address (see "Figure 54: CAM ROLLER POSITION" on page 48)

The lip chain, shackle retainer, lip chain spring function as an assembly to help activate the lip. They also serve the important function of stopping the dock levelers upward travel. They prevent the dock leveler from upward over travel. If these components break or are compromised, significant consequences may result. Confirm the proper placement and function of these components. If the components appear, worn damaged or compromised in any way discontinue the use of the dock leveler and replace the components immediately.

See the preceding adjustments pages for more information regarding adjustments to the dock leveler. Read the adjustments section entirely prior to making adjustments.

LUBRICATION: The recommended lubrication service interval is every 30 days or at a greater frequency as required in severe environments. **Dexron III Automatic Transmission Fluid is recommended.** Use EP2 Multi-purpose grease or equivalent to lubricate the area that makes contact between the lip yield clevis assembly, the yield mechanism assembly and lifting arm assembly (See "Figure 53: Lubrication Points" on page 47 and 39). It is strongly urged that a maintenance log be maintained with the dates of monthly inspections, the name of the inspector and results of the inspection.

NOTE: This dock leveler is easy to convert from the existing manual mechanical operation to hydraulic – push button operation by utilizing Pentalift's MDHCK conversion kit. (See (HYDRAULIC CONVERSION KIT - FOR CURRENT MECHANICAL DOCK LEVELER OWNER on page 36)

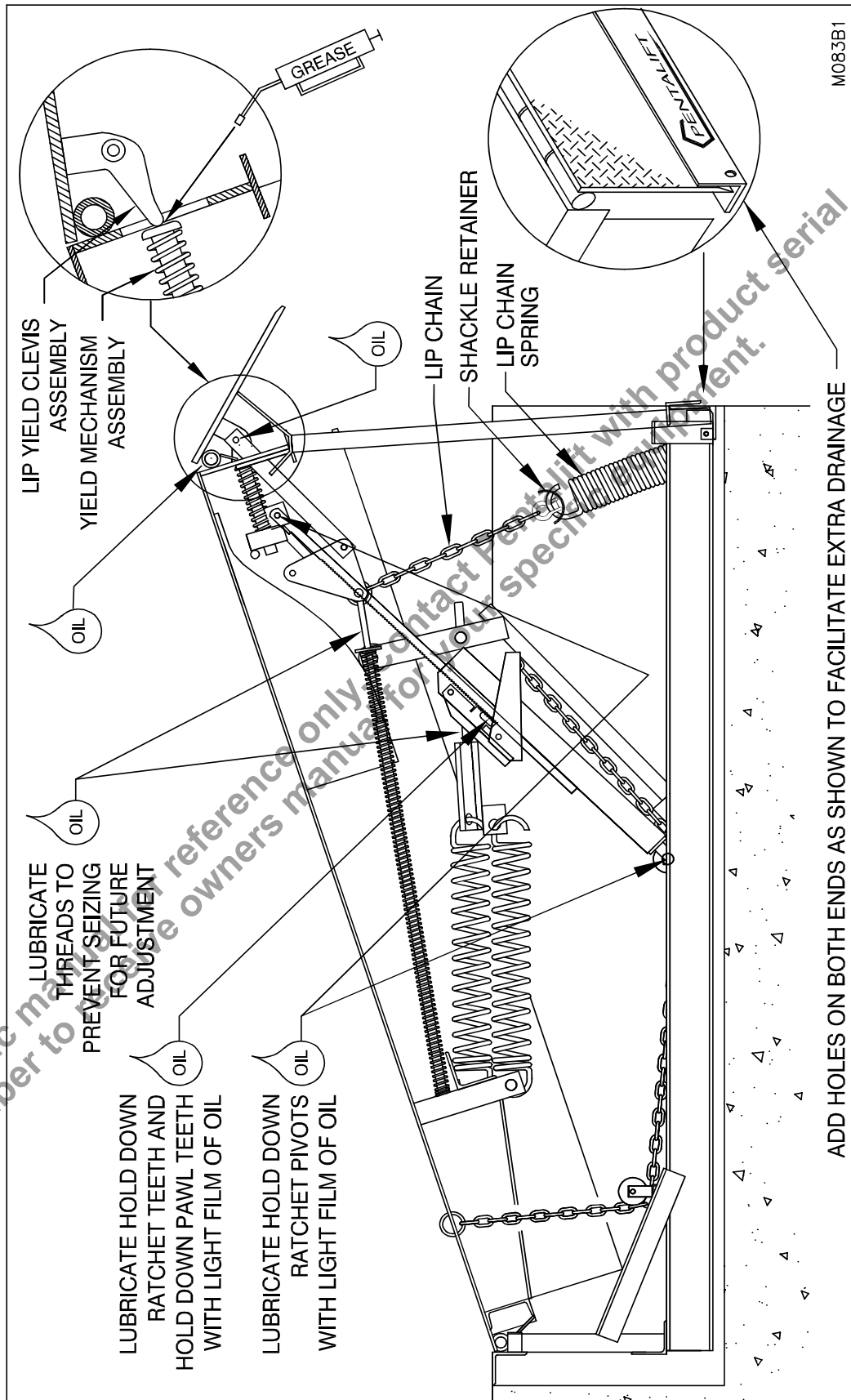

Figure 53: Lubrication Points

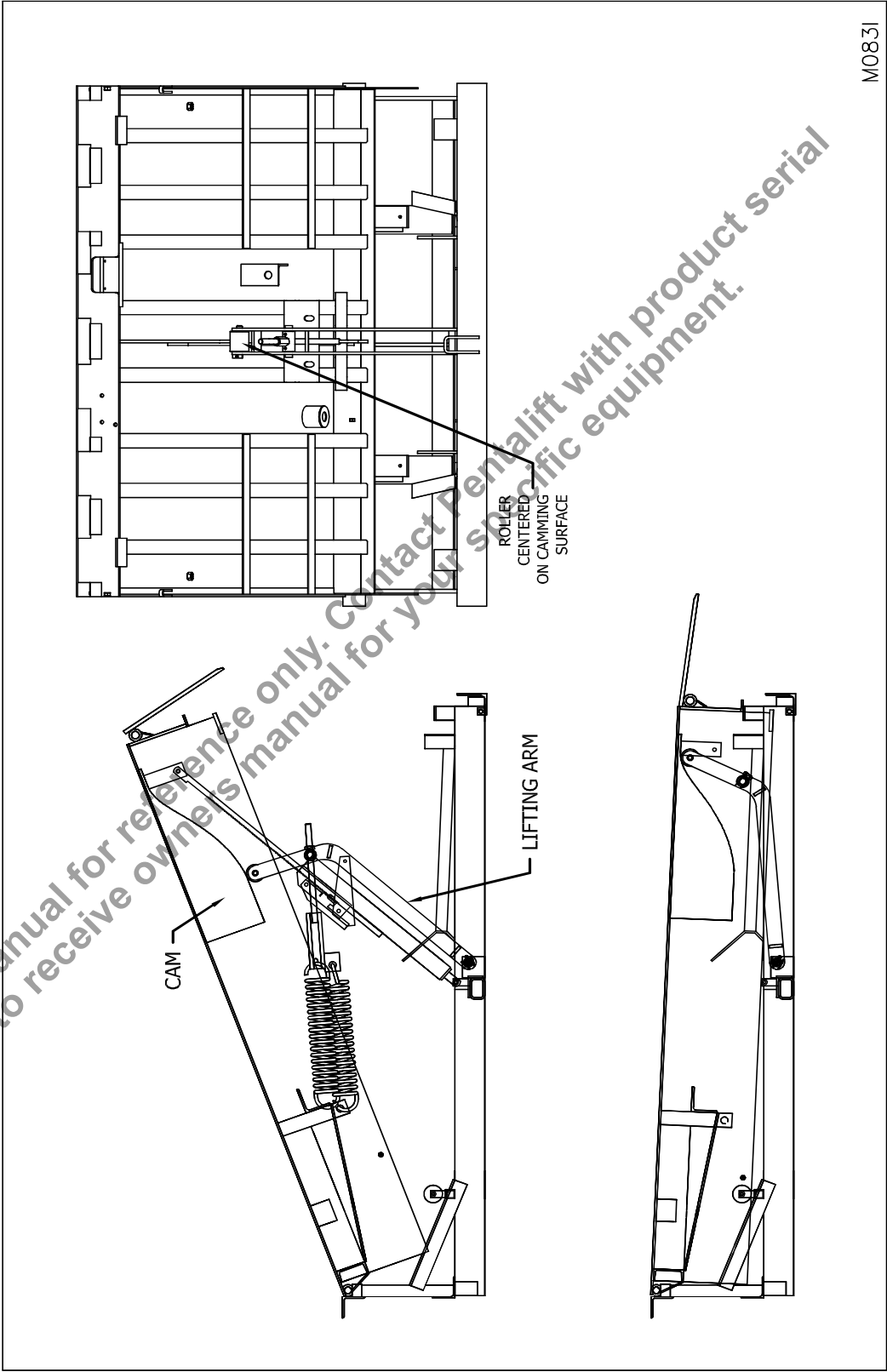

Figure 54: CAM ROLLER POSITION

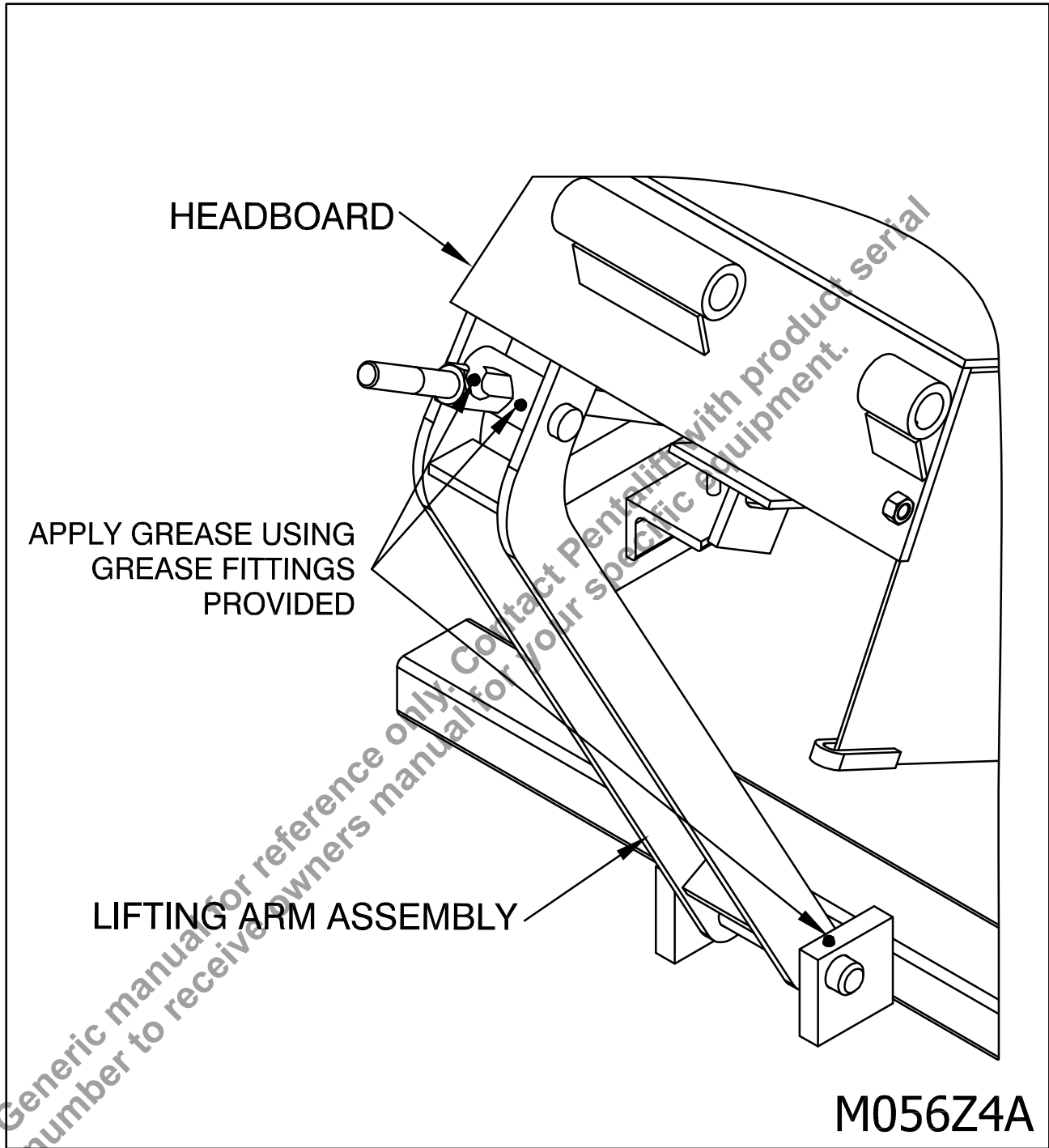

Figure 55.1: Lubrication Points for Lifting Arm Assembly

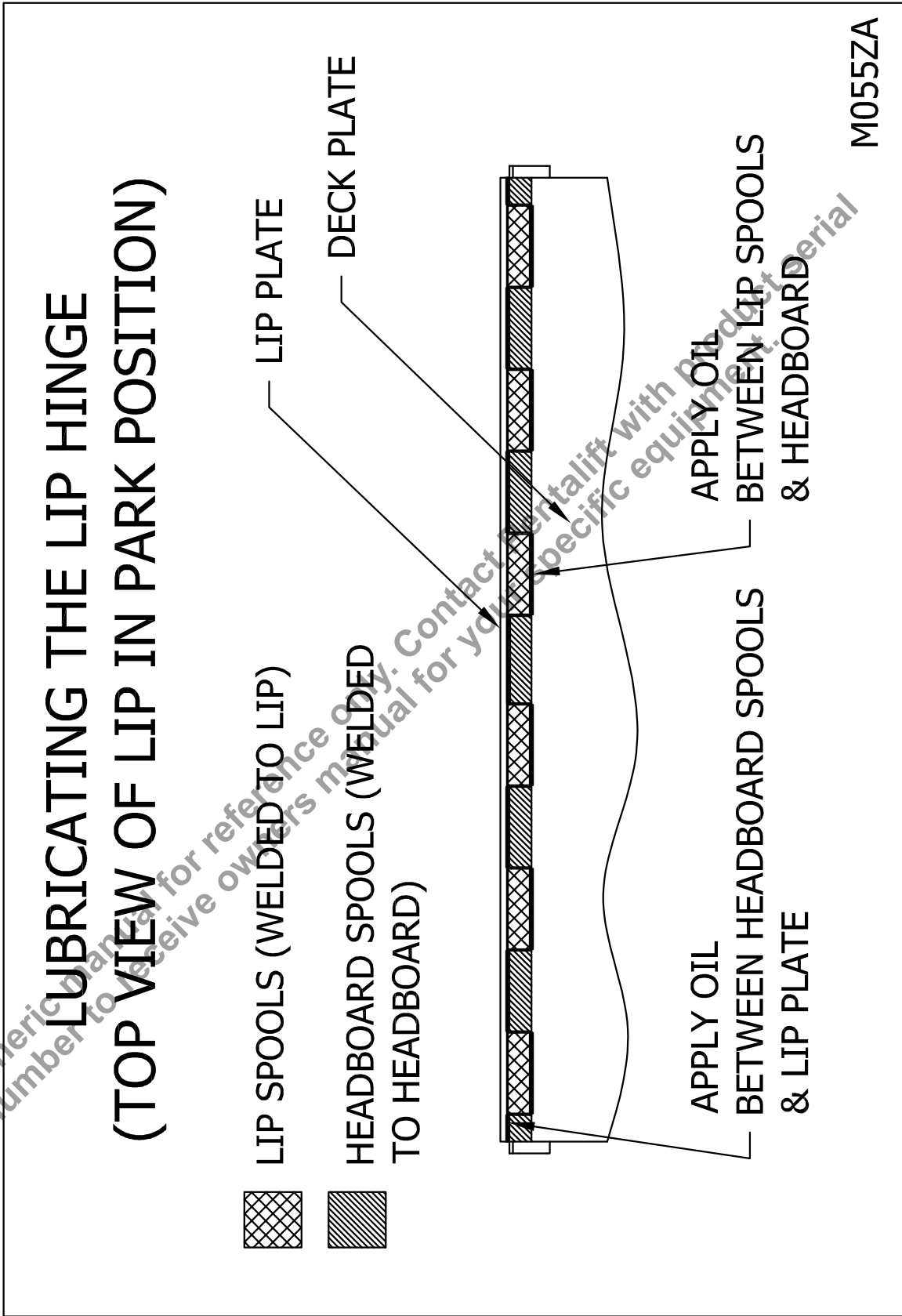

Figure 55.2: Lubrication Points (Lip spools and Headboard spools)

ADJUSTMENTS



ONLY TRAINED AND QUALIFIED PERSONNEL ARE TO PERFORM INSPECTION OR MAINTENANCE AND SERVICE PROCEDURES.



BEFORE DOING ANY INSTALLATION, MAINTENANCE, INSPECTION OR TROUBLE SHOOTING, BARRICADE ALL AREAS FROM TRAFFIC AROUND THE WORK AREA INSIDE (AND OUTSIDE IF APPLICABLE) FOR SAFETY AND POST APPROPRIATE WARNING SIGNS. NEVER GO BENEATH THE DOCK LEVELER FOR ANY REASON UNLESS THE LIP AND DECK ARE PROPERLY SUPPORTED BY THE MAINTENANCE STAND (SEE “SUPPORTING THE LEVELER FOR MAINTENANCE” on page 40). IT IS THE RESPONSIBILITY OF THE OWNER TO ENSURE THAT NO LOAD OR TRAFFIC IS PLACED ON THE DECK WHILE THE MAINTENANCE STAND IS IN USE. THE CONSTRUCTION OF THE MAINTENANCE STAND IS INTENDED TO SUPPORT THE WEIGHT OF THE UNLOADED DOCK LEVELER ONLY.

DO NOT PERFORM ANY ADJUSTMENTS UNTIL THE PIT AND LEVELER ARE CLEANED, CHECKED FOR OBSTRUCTIONS AND THAT ALL PROPER LUBRICATION IS COMPLETED. REFER TO “MAINTENANCE AND LUBRICATION” on page 45.

NORMAL SEQUENCES OF STEPS TO ADJUST MECHANICAL DOCK LEVELER THAT IS NOT PROPERLY FUNCTIONING

Whenever there is an issue with the operation of the mechanical dock leveler the following steps should be completed.

Note: The dock levelers are tested and set up at the factory. Over time, springs take a set and change in tension. As well site conditions and the friction of weather seal (if provided) can affect the required adjustments on the dock levelers.

1. **Do not** start by adding spring tension onto the dock leveler lift springs. This is the most common first step mistake that is made when addressing mechanical dock leveler issues. Adding lift spring tension at too high a level can be the source of other issues, including and not limited to: a) dock leveler deck twist when the dock leveler is in the parked position, b) hold down assembly not properly holding the dock leveler down or c) too high of a walk down force or weight required to lower the dock leveler.
2. Confirm that lip hinge assembly is free from debris and obstructions. Concrete, stucco, parging materials, nails, screws, pieces of wood from pallets and skids and other debris can be present at the hinge assembly. Any debris of this nature can inhibit the proper operation by creating additional friction or impediments to lips rotational engagement movement. Debris of this nature should be removed on a regular ongoing basis. The user of the equipment should be made aware of this concern and the need to clean and maintain this aspect of the dock leveler on a regular basis.
3. Make sure the dock leveler lip hinge assembly is properly lubricated in accordance with the owner’s manual instructions (see “MAINTENANCE AND LUBRICATION” on page 45).
4. Make sure the dock leveler lip spring adjustment is set at the correct level as the instructions on (see “LIP ASSIST SPRING ADJUSTMENT” on page 52). This is a vital adjustment. Proper adjustment of the lip assist spring will allow the lip spring adjustment to be minimized and avert the issues listing item 1 above.
5. Confirm that the hold-down is holding the deck correctly. (See ADJUSTMENTS TO LIP AND LIFT SPRINGS RELATIVE TO RATCHED HOLD DOWN on page 49)
6. Confirm that the dock leveler lift spring tension is properly set. The tension should be sufficient to extend the lip (with proper adjustment on the lip assist spring) but with not too heavy a walk down force. If the lip is fully extending when the dock leveler is activated, experiment with the lift spring tension by reducing the tension until the low possible walk down force required results but yet the lip still extends and locks when the dock leveler is activated from the stored / parked position. The goal is to balance the force required to extend the lip to lock when the dock leveler is activated against the a low walk down force. Activating the dock leveler by firmly pulling and holding the release chain to it’s full extent. If the lip continues to extend and lock the lift spring tension is sufficient. If the lip does not extend and lock more lift spring tension may be required. Again, you are working on a balance point.

LIP ASSIST SPRING ADJUSTMENT

Note: This is a very important adjustment that is often not understood or properly set up.

Note: On deck levelers with lighter lips additional spring assist tension is not required and therefore the lip spring bar is provided with no threads for adjustment. For dock levelers of this configuration lip tension adjustment is not provided.

The purpose of the lip assist spring adjustment is to provide a means of compensating for the dock leveler lip weight to the point that the dock leveler lip is downward bias but with a lower level of downward bias. The benefit of proper adjustment of the lip assist spring is that it reduces the lift spring tension required in order to make the dock leveler properly function and extend and lock the lip when the dock leveler is activated.

Adjusting the lip assist spring with too much spring tension will result in the lip not having sufficient downward bias to move to the pendent and parked position and to fully retract behind the lip keepers when the dock leveler is in the stored position. Too little lip assist spring adjustment may result in one or more of the following issues:

- 1) When the dock leveler is activated from the stored / parked position the dock leveler lip assembly will not rotate sufficiently high to allow full locking activation of the lip into the extended position. This puts the dock leveler in a condition where it is not usable.
- 2) If the lift springs are adjusted with more (and too much) tension to compensate for the insufficient adjustment of the lip assist spring this will result in one or more of the following issues:
 - a. Dock leveler deck twist when the dock leveler is in the parked position
 - b. The hold down assembly not properly holding the dock leveler down. The dock leveler deck drifts up when parked or bounces up as weight is driven over it. This is due to an overload of upward force due to too much lift spring tension.
 - c. Too high of a walk down force or weight required to lower the dock leveler after it is activated into the raised position with the lip extended.

To adjust the lip assist spring, release the lock nut and advance the adjustment nut clockwise 1 to 2 turns at a time (See "Figure 56: Lip Spring Adjustment" on page 53) to produce the appropriate tension to allow the lip to extend and lock the lip while still allowing the lip to fully fall to the pendant position when the lip is released. To determine when sufficient spring tension adjustment has been achieved hold the dock leveler lip at 45 degrees. It should take approximately 15 to 20 lbs of force maximum to hold the lip from falling when in this position. If the force is more add more lip assist spring tension if the force is less remove lip assist spring tension. Also confirm that from the 45 degree position when the lip is released (let go) by hand, it will fall to the fully pendant position. If it does not then remove lip assist spring tension.

Note: The length of the lip chain at the front of the dock leveler is preset at the factory. The length of this chain must not be altered. Lengthening of the chain will allow the deck to over-travel causing the lifting arm roller to roll off the back of the cam. Shortening the chain will interrupt the dock levelers lip extension or cause the lip to extend too early resulting in a lowered above level service range for the dock leveler.

Note: When replacing lip chain, extension spring chain and extension spring, ensure each component is properly connected, routed and secured to the appropriate connection points (see "Figure 57: Chain and Spring connection and routing for Lip Yieldable Mechanism" on page 54).

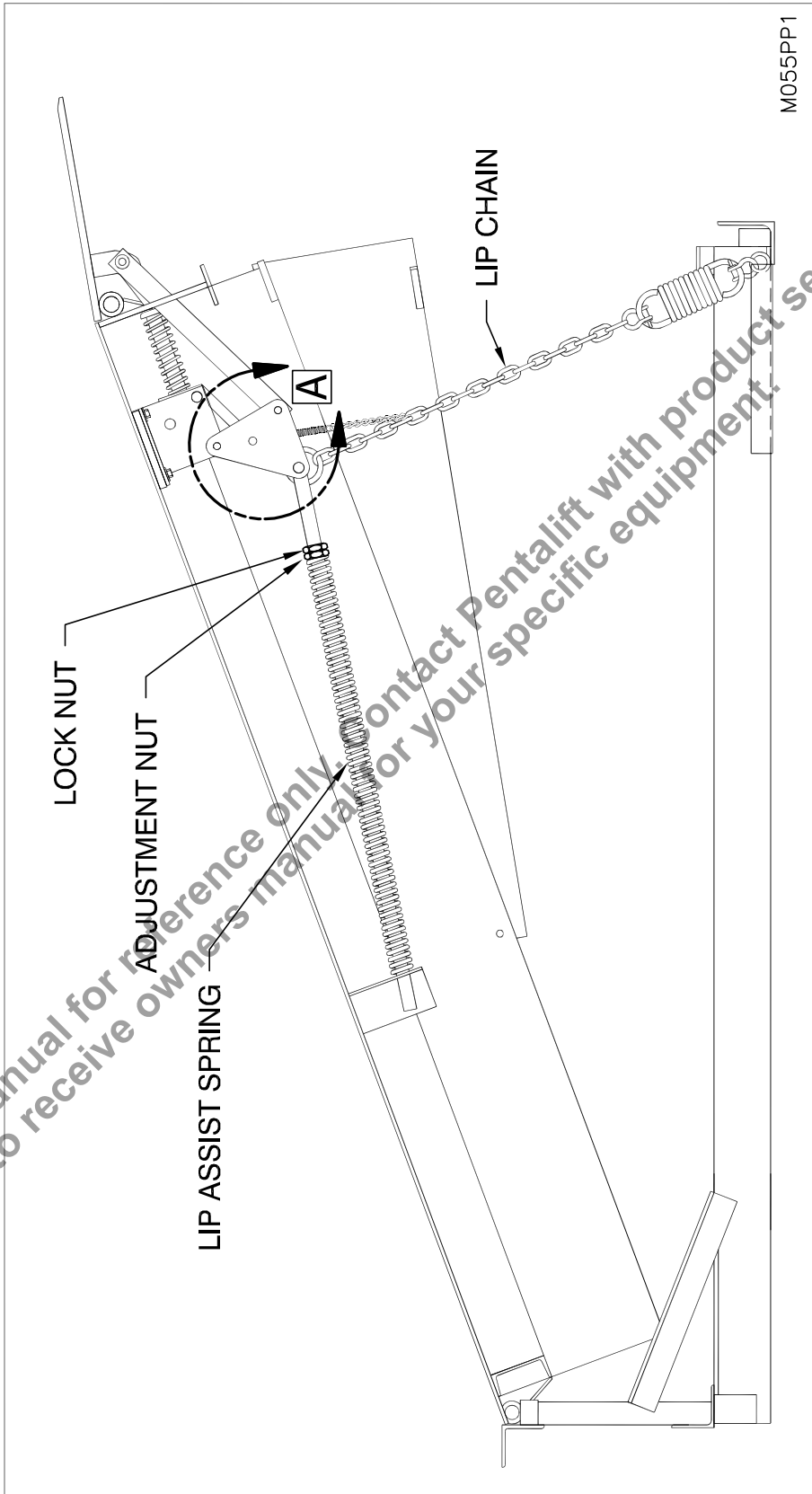

Figure 56: Lip Spring Adjustment

DETAIL "A"

(CONNECTION/ROUTING OF SPRINGS AND CHAINS)

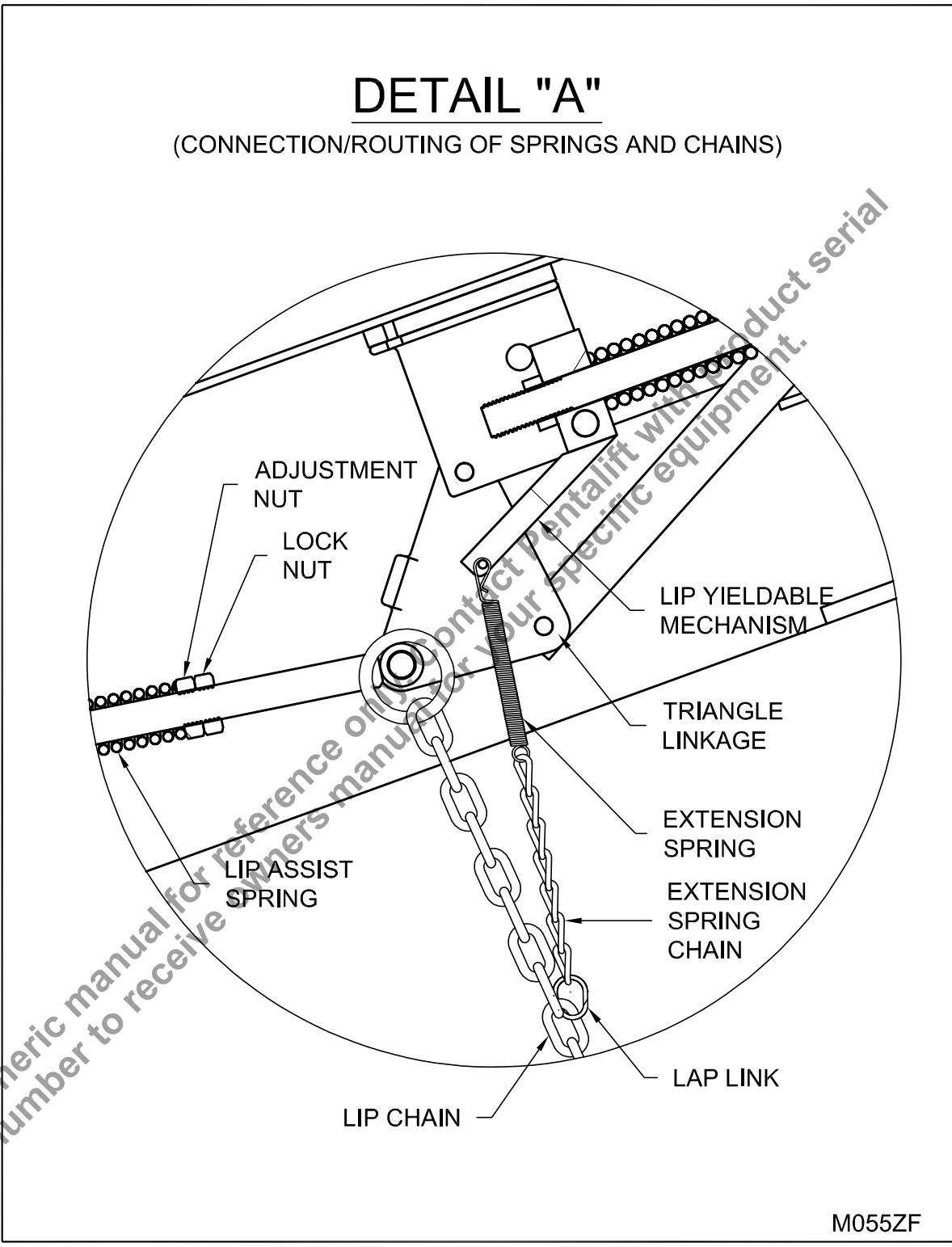

Figure 57: Chain and Spring connection and routing for Lip Yieldable Mechanism

MAIN LIFT SPRING ADJUSTMENT

Do not attempt to adjust the Main Lift Springs until the Lip Assist Springs have been adjusted. Refer to “Normal sequence to adjust Mechanical Dock Leveler that is not properly functioning” (see “NORMAL SEQUENCES OF STEPS TO ADJUST MECHANICAL DOCK LEVELER THAT IS NOT PROPERLY FUNCTIONING” on page 51). Proper adjustment of the main lift spring is to provide enough spring tension to allow the deck to fully rise with sufficient speed and force to completely extend and lock the lip at the fully raised position while not having too much tension. If the deck appears to have enough speed and force to fully raise the deck but the lip does not extend and lock refer to lip assist spring adjustment. Too much spring tension will make the leveler too hard to walk down into the working position, while too little spring tension will not allow the deck to fully rise or completely lock the lip. To adjust the spring tension, turn the coupling nut (See “Figure 58: Main Lift Spring Adjustment” on page 55) clockwise $\frac{1}{2}$ turn at a time. (Note: assure that the coupling nut maintains full thread contact with the spring plate weldment) Lower (walk) the leveler to the stored position. Activate the leveler and watch the action of the lip. If the deck appears to have enough speed to fully raise the deck but the lip does not extend and lock refer to lip assist spring adjustment.

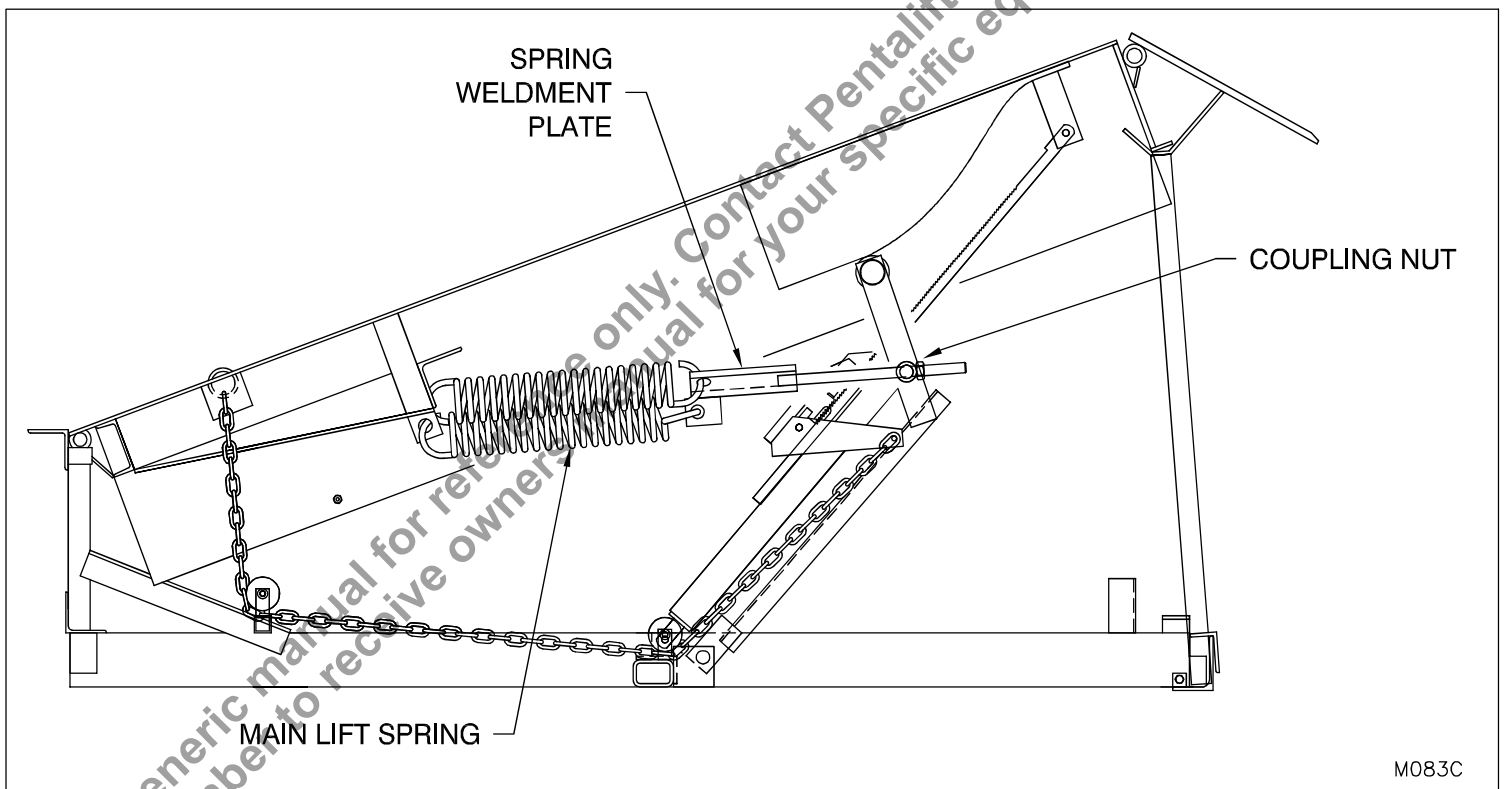

Figure 58: Main Lift Spring Adjustment

ADJUSTMENTS TO LIP AND LIFT SPRINGS RELATIVE TO RATCHET HOLD DOWN

If the deck of the dock leveler has a tendency to have an excessive upward float, confirm the Lip Assist and Main Lift Springs are properly adjusted. If the dock leveler raises back up slightly when it is “walked down” to the cross traffic or parked position, the ratchet or pawl may be worn or broken (with broken teeth) and require repair.

LIP YIELD MECHANISM

Lip Actuator and Lip Assist Chain connections and routings;

Visually confirm that the component, spring and chain arrangements and routing paths shown in these illustrations exist on the subject dock leveler (See “Figure 60: Chains and Spring Components” on page 57). If anything is missing or appears damaged then repair or replace to match the arrangement shown here. Look for damaged or worn springs or spring connections.

Note: The length of the lip chain at the front of the dock leveler is preset at the factory. It is important that the length of this chain not be altered. Lengthening of the chain could allow the deck to over-travel causing the lifting arm roller to roll off the back of the cam and other functional issues. Shortening the chain will reduce the above level range of the dock leveler as well as cause other functional issues.

The following is the lip chain length for the various dock leveler length: There may be additional unused links in the chain to achieve the correct lip chain length.

1. For a 6 foot long nominal length dock leveler, the lip chain length is 22 inches nominal.
2. For a 8 foot long nominal length dock leveler, the lip chain length is 23 3/4 inches nominal.
3. For a 10 foot long nominal length dock leveler, the lip chain length is 25 5/8 inches nominal.

The tolerances on the lip chain length is +3/8 and -1/4 inches.

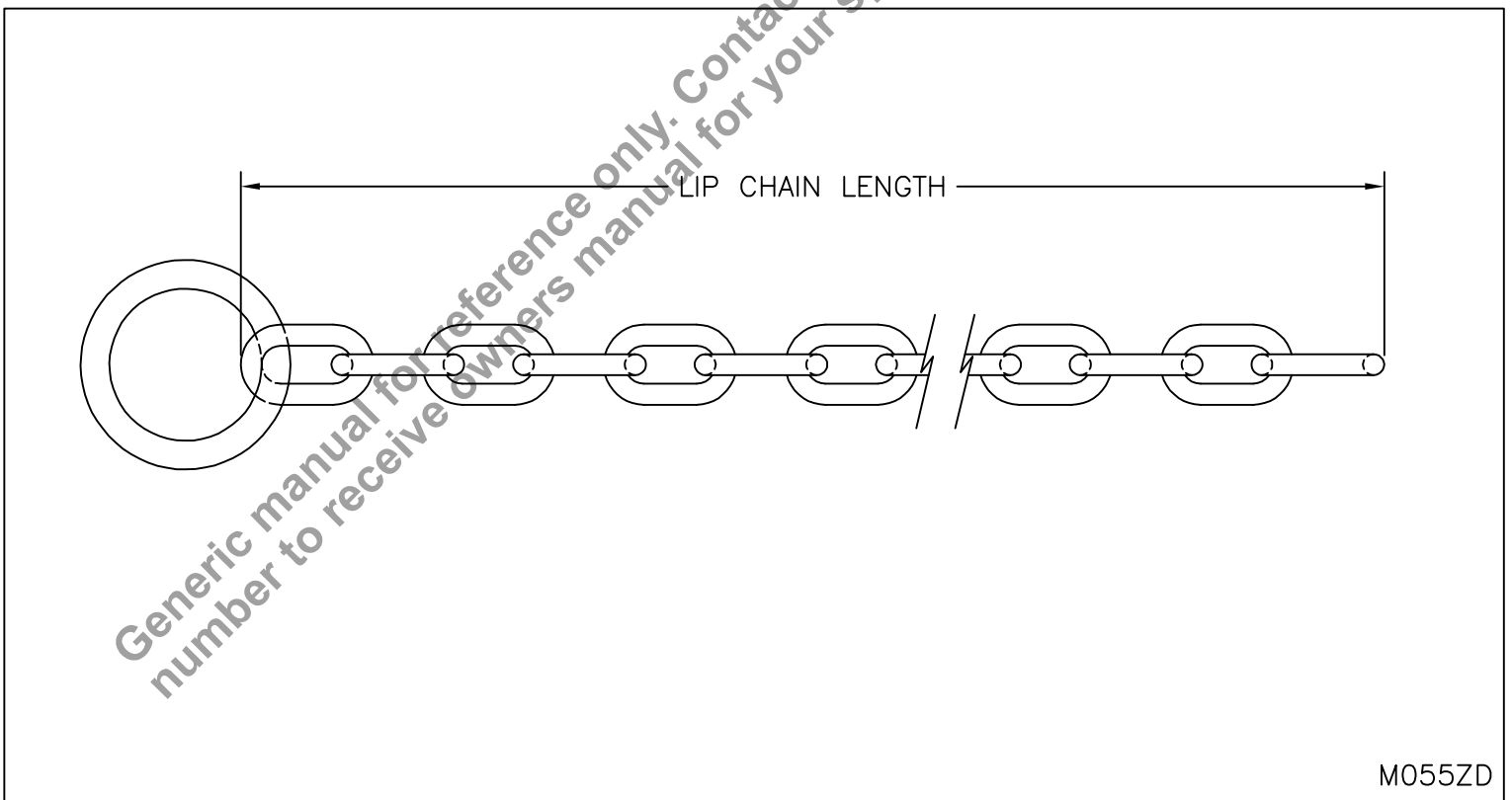

Figure 59: Lip Chain

NOTE: This dock leveler is easy to convert from the existing manual mechanical operation to hydraulic – push button operation by utilizing Pentalift’s MDHCK conversion kit. (See (HYDRAULIC CONVERSION KIT - FOR CURRENT MECHANICAL DOCK LEVELER OWNER on page 36)

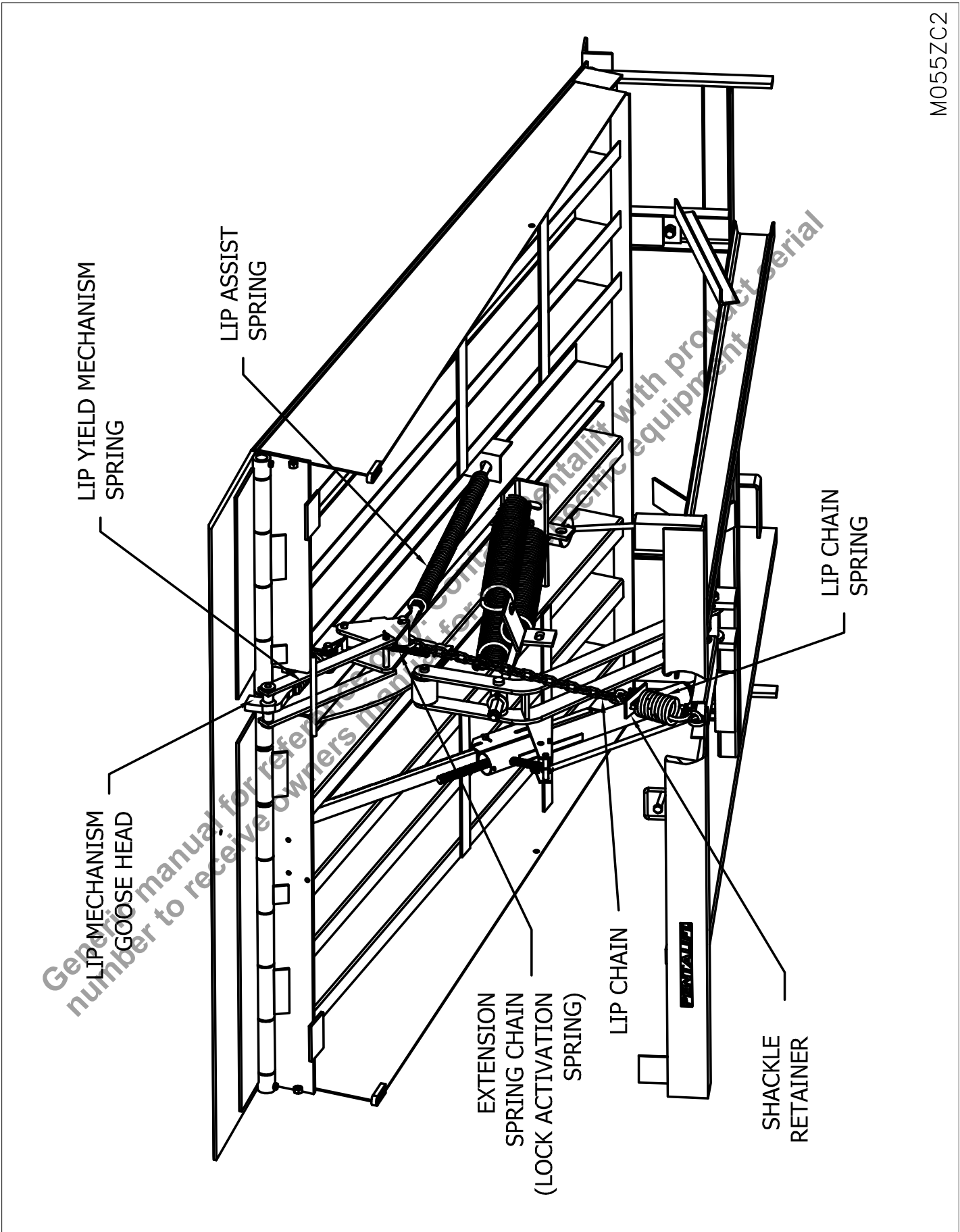

Figure 60: Chains and Spring Components

TROUBLE SHOOTING GUIDE

NOTE: This equipment has been fully tested and confirmed to be operational at the factory. Historically, the majority of operating problems are caused by unnecessary tampering or improper adjustment. To conform to the terms of the warranty, contact your authorized Pentalift representative if you are having any difficulty with the leveler during the warranty period. Do not risk voiding the warranty by incorrectly adjusting or tampering with the equipment.



ONLY TRAINED AND QUALIFIED PERSONNEL ARE TO PERFORM INSPECTION OR MAINTENANCE AND SERVICE PROCEDURES.

A mechanical dock leveler functions through the use of stored spring energy. On your Pentalift mechanical dock leveler there are two areas where spring energy is utilized; the first area is the main lift spring assembly. These springs are located in the center of the dock leveler; suspended from the underside of the deck to the back frame. The main lift springs pull on the cantilever lifting arm causing the dock leveler deck to be biased upwards. Too little tension on these springs will cause the dock leveler deck to raise with insufficient force to function properly. Too much tension on these springs will cause the dock leveler to lift with too much force and also be difficult to walk down. Refer to "MAIN LIFT SPRING ADJUSTMENT" on page 55.

The second area where spring energy is utilized is in the lip actuator assembly. The lip actuator assembly extends and locks the lip. Under-adjustment of the lip assist spring will cause the lip to be effectively too heavy for optimal operation of the dock leveler. Over-adjustment of the lip assist spring will cause the lip to be effectively too light and may create a situation where the lip will not retract to its pendant position upon truck departure. Refer to "LIP ASSIST SPRING ADJUSTMENT" on page 52.

It is important to understand that because this is a mechanical device relying on a proper "balance" between various mechanisms for proper operation. Improper adjustment can deteriorate the performance of your dock leveler and create dangerous situations. Never extend the length of the lip chain. **Any adjustments must be made by factory authorized service technicians.**

Below are some common symptoms and potential corrective actions. Utilizing these points of information make sure that all aspects of the normal sequence of steps to adjust the mechanical dock leveler have been followed (see "NORMAL SEQUENCES OF STEPS TO ADJUST MECHANICAL DOCK LEVELER THAT IS NOT PROPERLY FUNCTIONING" on page 51).



BEFORE DOING ANY INSTALLATION, MAINTENANCE, INSPECTION OR TROUBLE SHOOTING, BARRICADE ALL AREAS FROM TRAFFIC AROUND THE WORK AREA INSIDE (AND OUTSIDE IF APPLICABLE) FOR SAFETY AND POST APPROPRIATE WARNING SIGNS. NEVER GO BENEATH THE DOCK LEVELER FOR ANY REASON UNLESS THE LIP AND DECK ARE PROPERLY SUPPORTED BY THE MAINTENANCE STAND (SEE "SUPPORTING THE LEVELER FOR MAINTENANCE" on page 40). IT IS THE RESPONSIBILITY OF THE OWNER TO ENSURE THAT NO LOAD OR TRAFFIC IS PLACED ON THE DECK WHILE THE MAINTENANCE STAND IS IN USE. THE CONSTRUCTION OF THE MAINTENANCE STAND IS INTENDED TO SUPPORT THE WEIGHT OF THE UNLOADED DOCK LEVELER ONLY.

Deck fails to rise when release ring is pulled.

1. Confirm the release chain is fully pulled quickly to its stopping point and held at the stopping point until the dock leveler discontinues to move. Partially pulling the chain or letting the chain go too soon will cause the dock leveler to malfunction.
2. Check release chain to ensure it is properly attached to release arm.
3. Check for any friction points that may be holding the dock leveler from moving.
4. Follow all steps of steps to adjust main lift spring (see "MAIN LIFT SPRING ADJUSTMENT" on page 55).
5. If the problem cannot be solved, consult your authorized Pentalift representative.

Deck fails to rise completely and or the dock leveler lip fails to extend when the release ring is pulled.

1. Confirm the release chain is fully pulled quickly to its stopping point and is held at the stopping point until the dock leveler discontinues to move. Partially pulling the chain or letting the chain go too soon will cause the dock leveler to malfunction.
1. Ensure all steps have been properly followed to adjust main lift spring and/or lift assist spring (see “ADJUSTMENTS” on page 51)
2. Check for debris or obstruction that may interfere with the operation of any moving parts. Specifically inspect & remove any debris or obstructions in the lip hinges of the dock leveler.
3. If the problem cannot be solved, consult your authorized Pentalift representative.

Deck cannot be walked down.

- 1) Confirm that the weight of the person walking down the dock leveler is sufficient. The weight required will vary depending on the size and configuration of the dock leveler.
- 2) Check deck assembly for obstruction.
- 3) Too much main lift spring tension or improper adjustment (see “ADJUSTMENTS” on page 51). Follow all steps under sequence of adjustment.
- 4) If the problem cannot be solved, consult your authorized Pentalift representative.

Deck drifting up when parked.

1. Confirm the release chain and link is not binding and preventing the ratchet from fully engaging.
2. Inspect that no foreign substances such as grease, paint or dirt are on the ratchet teeth. Remove any foreign substances that may interfere with the operation of the hold down.
3. Check for broken teeth on the ratchet or pawl. Replace damaged ratchet and pawl.
4. Excessive lift spring tension. Excessive lift spring tension results in an overloading of upward force on the hold down, which results in ratchet slippage. Follow steps on dock leveler set up. (see “ADJUSTMENTS” on page 51)
5. If the problem cannot be solved, consult your authorized Pentalift representative.

Lip will not return to pendant position.

- 1) Inspect lip spools for debris or obstruction.
- 2) Make sure the dock leveler is properly lubricated. Focus in particular on the lip hinge maintenance. (See “MAINTENANCE AND LUBRICATION” on page 45)
- 3) Lip assist spring is out of adjustment (see “ADJUSTMENTS” on page 51).
- 4) If the problem cannot be solved, consult your authorized Pentalift representative.

Lip Fails to Extend and Lock When Dock Leveler is Activated.

1. Follow all steps under sequence of steps for addressing dock leveler.
2. If the problem cannot be solved, consult your authorized Pentalift representative.

If damaged or worn parts are detected upon inspection, replacement must be undertaken **immediately**. **The dock leveler must not be used until replacement is completed.** Parts are readily available from your Pentalift representative.

NOTE: This dock leveler is easy to convert from the existing manual mechanical operation to hydraulic – push button operation by utilizing Pentalift’s MDHCK conversion kit. (See (HYDRAULIC CONVERSION KIT - FOR CURRENT MECHANICAL DOCK LEVELER OWNER on page 36)

REPLACEMENT PARTS

USE ONLY GENUINE PENTALIFT REPLACEMENT PARTS



To ensure proper functioning, durability and safety of the product, only genuine pentlift replacement parts must be used. Altering the product from its original manufactured configuration must not be done. Pentlift equipment Corporation disclaims all liability for failure to comply with this warning. Warranties are specifically disclaimed in the event the purchaser fails to comply with this warning.

To expedite order processing when ordering parts, provide the following information to your Pentlift representative:

1. Model and Serial Number of equipment.
2. Part Number, Description and Quantity.
3. Shipping Instructions.

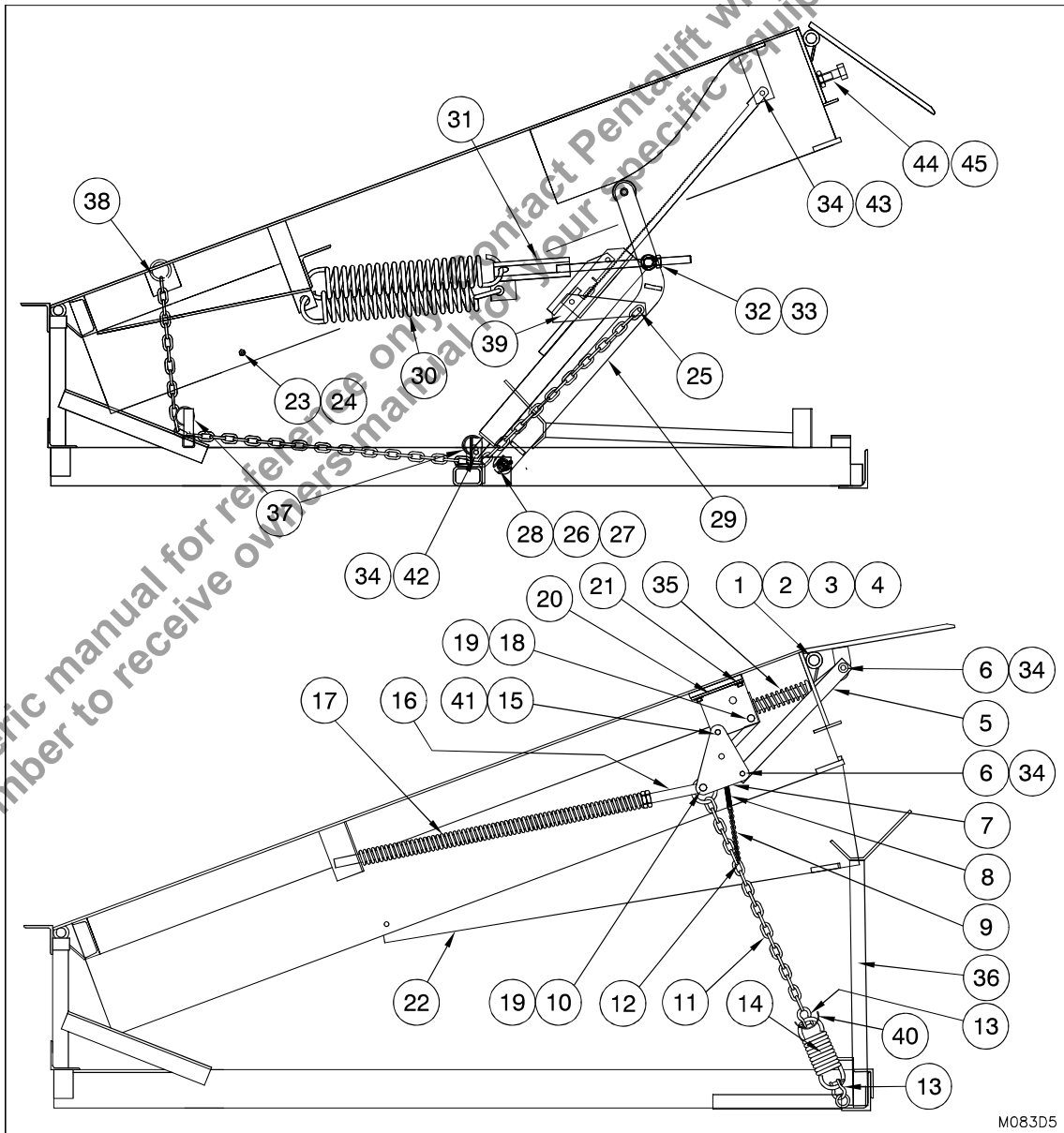

Figure 61: Dock Leveler Replacement Parts

NOTE: State Model # and Serial # when ordering replacement parts.

DOCK LEVELER REPLACEMENT PARTS

USE ONLY GENUINE PENTALIFT REPLACEMENT PARTS

| <u>Item #</u> | <u>Part No.</u> | <u>Description</u> | <u>Item #</u> | <u>Part No.</u> | <u>Description</u> |
|---------------|-----------------|---|---------------|-----------------|--|
| 1 | 302-0379 | Lip Pin for 6 ft wide deck | 23 | 072-0095 | Toe Guard Bolt |
| | 302-0381 | Lip Pin for 7 ft wide deck | 24 | 070-0022 | Toe Guard Lock-Nut |
| 2 | 072-0018 | Lip Pin Retaining Bolt | 25 | 087-0173 | Lap Link 1/8" |
| 3 | 070-0013 | Lip Pin Retaining Nut | 26 | 302-9007 | Lifting Arm Pivot |
| 4 | 074-0025 | Lip Pin Retaining Washer | 27 | 080-0001 | Spring Pin |
| 5 | 302-1010 | Middle Linkage Arm | 28 | 052-0170 | Grease fitting |
| 6 | 302-1023 | Middle Linkage Pin | 29 | 802-3099 | Lifting Arm Weldment |
| 7 | 802-1830 | Triangle Linkage Weldment | 30 | 302-0390 | Lift Spring |
| 8 | 302-9100 | Extension Spring | 31 | 802-3975 | Spring Plate Weldment (3) |
| 9 | 302-1085 | Extension Spring Chain | | 802-3974 | Spring Plate Weldment (4) |
| 10 | 302-1026 | Lip Assist Rod Pin | | 802-3973 | Spring Plate Weldment (5) |
| 11 | NOTE | Lip Chain for a (see note below) | 32 | 074-0035 | Washer 3/4" |
| | 802-2307 | 6 & 8 ft long dock leveler | 33 | 070-0082 | Coupling Nut 3/4" |
| | 802-2308 | 10 ft long dock leveler | 34 | 082-0001 | 1/8" x 1" Cotter Pin |
| 12 | 087-0159 | Lap Link 3/16" | 35 | 802-1832 | Lip Yield Mechanism Assembly |
| 13 | 087-0037 | Shackle 5/16" | 36 | 802-2716 | Maintenance Stand |
| 14 | 302-0951 | Lip Chain Spring | 37 | 302-1509 | Chain Roller |
| 15 | 302-1025 | Triangle Linkage Pin | 38 | 802-2764 | Release Chain for 6ft Deck |
| 16 | NOTE | Lip Assist Weldment for a | | 802-2765 | Release Chain for 8ft Deck |
| | 802-3191 | 16" lip and 1/2" thick lip plate | | 802-2766 | Release Chain for 10ft Deck |
| | 802-1828 | Lip greater than 16" and/or lip thickness greater than 1/2" | 39 | 500-0167 | Ratchet Hold Down |
| 17 | 302-1004 | Lip Assist Spring | 40 | 302-9048 | Rubber Shackle Retainer |
| 18 | 302-1024 | Yield Mechanism Pivot Pin | 41 | 080-0026 | Spring Pin 3/16" x 3/4" |
| 19 | 082-0010 | Cotter Pin 3/16" x 2" | 42 | 080-0040 | Clevis pin 1/2" x 1-5/8" |
| 20 | 802-1829 | Bracket Box Weldment | 43 | 080-0039 | Clevis pin 1/2" x 2-3/32" |
| 21 | 072-0362 | Bracket Box Bolts 3/8" | 44 | 072-0250 | Hex Head Bolt (for lips which park in front angle) |
| 22 | NOTE | Full Range Toe Guards (Optional) | 44 | 072-0409 | Hex Head Bolt (for lips with lip keepers) |
| | 302-1053 | 10 ft Upper | 45 | 072-0021 | Hex Nut |
| | 302-1054 | 10 ft Lower | | | |
| | 302-1048 | 8 ft Upper | | | |
| | 302-1051 | 6/8 ft Lower | | | |
| | 302-1050 | 6 ft Upper | | | |

NOTE: State Model # and Serial # when ordering replacement parts.

For the Lip Chain (Item 11), the same part is used on a 6ft. and 8ft. long dock leveler. The position of the connecting shackle is different for a different effective length. There may be additional unused link in the chain.

See Figure 56: Lip Chain on page 50.

OPTIONAL FALLSAFE REPLACEMENT PARTS

USE ONLY GENUINE PENTALIFT REPLACEMENT PARTS

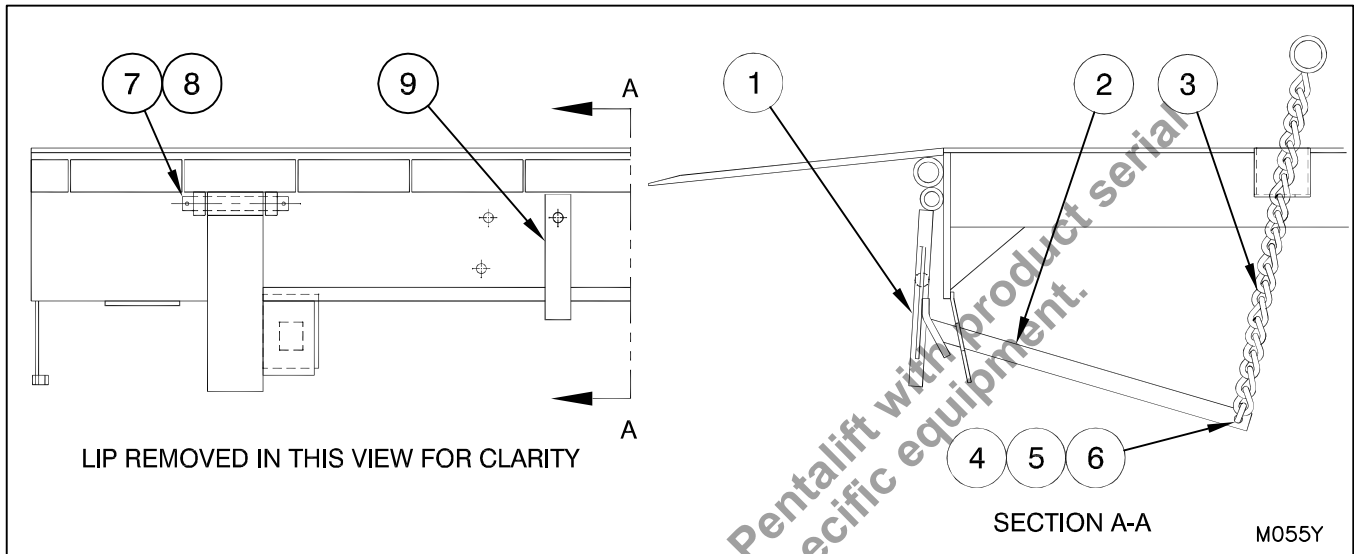

Figure 62: Optional Fallsafe Replacement Parts

| <u>Item #</u> | <u>Part No.</u> | <u>Description</u> |
|---------------|-----------------|-----------------------|
| 1 | 802-2013 | Fallsafe Leg Assembly |
| 2 | 802-2751 | Push Tube |
| 3 | 802-1026 | Chain Assembly |
| 4 | 072-0005 | Bolt |
| 5 | 070-0018 | Nut |
| 6 | 074-0006 | Washer |
| 7 | 302-0634 | Pin |
| 8 | 082-0010 | Cotter Pin |
| 9 | 302-1154 | Spring Bar |

NOTE: State Model # and Serial # when ordering replacement parts.

LIST OF ILLUSTRATIONS

| | |
|--|----|
| Figure 1: Precautionary Labels | 2 |
| Figure 2: Precautionary Label Locations | 3 |
| Figure 2a: Precautionary Label Locations - Front Angle | 3 |
| Figure 3: Hoist Using Lifting Devices. | 6 |
| Figure 5: Shim Front Frame. | 7 |
| Figure 6: Shim Rear Frame | 7 |
| Figure 4: Shipping Wire, Bolts and Lifting Devices | 7 |
| Figure 7: Wedging the Rear Frame Angle to the Rear Pit Curb Angle | 8 |
| Figure 8: Weld to Rear Curb Angle | 8 |
| Figure 9: Weld to Front Curb Angle | 9 |
| Figure 10: Shim Beneath Lifting Arm Bracket | 9 |
| Figure 11: Top Flange Removal Diagram | 9 |
| Figure 12: Tighten the Shackle | 10 |
| Figure 13: Curb Angle Force Chart. | 11 |
| Figure 15: C-channel Shims | 12 |
| Figure 14: Rear Shim (4" Shim Kit Shown) | 12 |
| Figure 17: Hoist Leveler with Chain | 13 |
| Figure 16: Rear Shim Location (4" High Rear Shim Shown) | 13 |
| Figure 18: Top Flange Removal Diagram | 14 |
| Figure 19: 30,000 lb + Outer Rear Shims (4" Shim Kit Channel Shim Shown) | 14 |
| Figure 20: Welding the 3 X 3 Square Tubing to the Curb Angles. | 16 |
| Figure 21: Welding the 4 X 3 Rectangular Tubing to the Curb Angles | 16 |
| Figure 22: Welding the 4 X 3 Rectangular Tubing to the Curb Angles | 17 |
| Figure 23: Installing the filler plate | 17 |
| Figure 24: Welding the 4 X 3 Rectangular Tubing to the Curb Angles | 18 |
| Figure 25: Installing the filler plate | 19 |
| Figure 26: Front Angle and Optional Fallsafe Support Block Shims | 20 |
| Figure 27: Thrust Beam Shims | 20 |
| Figure 28: Rear Shims | 21 |
| Figure 29: Rear Angle Flush with Curb Angle | 21 |
| Figure 30: Pour-In Pan Components | 23 |
| Figure 31: Foundation cut out and support pad | 24 |
| Figure 33: One Inch (1") Gap. | 25 |
| Figure 32: Dock Leveler in Position | 25 |
| Figure 34: Shipping Wire, Bolts and Lifting Devices. | 25 |
| Figure 36A: Shimming 20" Lips | 26 |
| Figure 35: Deck Alignment | 26 |
| Figure 36: Shimming 16" & 18" Lips | 26 |
| Figure 37: Dock Leveler Installed | 27 |
| Figure 38: DB13 Installation | 29 |
| Figure 39: PLB414AF Installation | 29 |
| Figure 40: PLB414AA Installation | 30 |
| Figure 41: Lift Until Liplock Releases. | 32 |

| | |
|--|----|
| Figure 42: Lower Until Vertical | 32 |
| Figure 43: Deck in Stored Position | 34 |
| Figure 44: Walk Down the Deck | 35 |
| Figure 45: 4" Penetration | 35 |
| Figure 46: Hydraulic Conversion Kit | 37 |
| Figure 47: Below Level Control Operation | 38 |
| Figure 48: Lip Keeper | 38 |
| Figure 50: Below Level End Loads | 39 |
| Figure 49: End Loading/ Unloading | 39 |
| Figure 51: Supporting the Dock Leveler for Maintenance | 41 |
| Figure 51.1: Supporting the Dock Leveler with the Auxiliary Maintenance Stand | 42 |
| Figure 52: Supporting the Dock Leveler with Mechanical Fallsafe | 43 |
| Figure 53: Lubrication Points | 46 |
| Figure 54: CAM ROLLER POSITION | 47 |
| Figure 55.1: Lubrication Points for Lifting Arm Assembly | 48 |
| Figure 55.2: Lubrication Points (Lip spools and Headboard spools) | 49 |
| Figure 56: Lip Spring Adjustment | 52 |
| Figure 57: Chain and Spring connection and routing for Lip Yieldable Mechanism | 53 |
| Figure 58: Main Lift Spring Adjustment | 54 |
| Figure 59: Lip Chain | 55 |
| Figure 60: Chains and Spring Components | 56 |
| Figure 61: Dock Leveler Replacement Parts | 59 |
| Figure 62: Optional Fallsafe Replacement Parts | 61 |
| Figure 63: Adjustable Lip Stop | 44 |

Generic manual for reference only. Contact Pentalift with product serial number to receive owners manual for your specific equipment.

PENTALIFT EQUIPMENT CORPORATION WARRANTY

WARRANTY

Pentalift Equipment Corporation expressly warrants that any product manufactured by **Pentalift Equipment Corporation** will be free from defects in material and workmanship under normal use for a period of one (1) year from the date of shipment of the equipment, provided the original purchaser maintains and operates the product in accordance with proper procedures. In the event the product proves defective in material or workmanship, **Pentalift Equipment Corporation** will at its option:

1. Replace the product or the defective portion thereof without charge to the purchaser; or
2. Alter or repair the product; on site or elsewhere, as **Pentalift Equipment Corporation** may deem advisable, without charge to the purchaser.

The warranty stated in the previous paragraph is that expressed by **PENTALIFT EQUIPMENT CORPORATION** AND IS IN LIEU OF ALL GUARANTEES AND WARRANTIES, EXPRESSED OR IMPLIED BY ANYONE OTHER THAN **PENTALIFT EQUIPMENT CORPORATION**. This warranty does not cover any failure caused by improper installation, misapplication, overloading, abuse, negligence, or failure to lubricate and adjust or maintain the equipment properly and regularly. Parts requiring replacement due to damage resulting from abuse, improper operations, improper or insufficient lubrication, lack of proper protection or vehicle impact are not covered by this warranty. **Pentalift Equipment Corporation** assumes no responsibility or liability for:

1. Consequential damages of any kind which result from use or misuse of the equipment
2. Damage or failure resulting from the use of unauthorized replacement parts
3. Damage or failure resulting from modification of the equipment
4. Damage resulting from the misuse of the equipment

THERE ARE NO WARRANTIES, EXPRESSED OR IMPLIED, WHICH EXTEND BEYOND THE DESCRIPTION ON THE FACE HEREOF, AND THERE IS NO WARRANTY OF MERCHANTABILITY OR OF FITNESS FOR A PARTICULAR PURPOSE.

Pentalift Equipment Corporation warranties extend only to the original product itself. In no event shall **Pentalift Equipment Corporation** be responsible for or liable to anyone, including third parties, for special, indirect, collateral, punitive, incidental or consequential damages, even if Pentalift Equipment Corporation has been advised of the possibility of such damages. Such excluded damages include, but are not limited to, loss of good will, loss of profits, loss of use, interruption of business or other similar indirect financial loss.

Pentalift Equipment Corporation DISCLAIMS all liability arising out of the workmanship, methods and materials used by the installer.

Pentalift Equipment Corporation DISCLAIMS all liability for premature product wear, product failure, property damage or bodily injury arising from improper installation and application.

Pentalift Equipment Corporation will not accept any warranty for which the original purchaser does not notify **Pentalift Equipment Corporation's** Warranty Department of the defect within ninety (90) days after the product defect is discovered. A fully completed Product Registration Card is required prior to the review or processing of any warranty requests or claims.

WARRANTIES, whether expressed or implied, relating to workmanship and materials used in connection with the installation of **Pentalift Equipment Corporation** products are specifically DISCLAIMED.

WR001R03

PENTALIFT EQUIPMENT CORPORATION

P.O. Box 1510, Buffalo, NY 14240-1510, U.S.A 21 Nicholas Beaver Rd. Puslinch, ON N0B 2J0, Canada
(519) 763-3625 Fax (519) 763-2894
www.pentalift.com