



## PENTALIFT EQUIPMENT CORPORATION

# PENTALOCK HFR32 VEHICLE RESTRAINT OWNERS MANUAL

SERIAL NUMBER : \_\_\_\_\_

Individual Serial Number(s) must be filled out by the user for future reference.

**This manual is an important document.**

It shall be kept with the machine or located where readily available to operators and maintenance personnel for reference purposes. Do not install, operate or service this product unless you have read and fully understand the entire contents of this manual. Failure to do so may result in property damage, bodily injury or death. Keep this manual in a safe place for future reference.

**NOTE:** A very high level of field issues with this type of equipment can be directly attributed to improper or incomplete installation. The installation instructions and information provided for this equipment is thorough. A step by step sequence for installation is provided. All steps must be followed and completed to provide a complete installation. Incomplete or improper installations can lead to equipment malfunction and / or damage, create safety issues and void warranties. Please follow all installation and set ups steps as indicated in the installation instructions and owner's manual. If you are unclear or uncertain regarding any of the steps contact your Pentalift representative for clarification. A copy of the completed steps listing with the sign off and photos of the installation as indicated at the conclusion of the installation instructions will be required prior to any Pentalift factory trouble shooting assistance.

**Pentalift Equipment Corporation  
21 Nicholas Beaver Rd  
Puslinch, ON N0B 2J0  
Phone: 519-763-3625  
Fax: 519-763-2894  
Parts Phone: 519-763-3625 Extension 625  
Ask for Parts Department**

**Pentalift Equipment Corporation provides an owners manual when equipment is shipped. Additional manuals are available at \$25.00 each.**

**IMPORTANT:** The owners manuals that are provided on Pentalift Equipment Corporations website are generic in nature. They are provided for general information only. For all purposes, only the owners manual that is specific to the equipment should be referenced and relied on. In order to receive the specific owners manual for specific Pentalift equipment, please contact your Pentalift representative and supply the specific serial number(s) for the equipment the manual is required for. Do not rely on the information in the generic owners manuals provided through the website as it may not be appropriate for your specific Pentalift equipment.

# PRODUCT REGISTRATION



## PRODUCT REGISTRATION CARD

To validate warranty and to advise of product updates  
please complete the following information and return to  
**Pentalift Equipment Corporation**  
To validate warranty on-line go to: [www.pentalift.com](http://www.pentalift.com)

### End User Information

*Company Name:		
Contact *First Name:	*Last Name:	Title:
*Mailing Address:		
*City:	*State/Prov.	*Zip/Postal Code:
*Phone: ( ) -	Fax: ( ) -	Email:
Check Products Purchased: <input type="checkbox"/> Levelers, <input type="checkbox"/> Vehicle Restraints, <input type="checkbox"/> Seals/Shelters, <input type="checkbox"/> Elevating Docks, <input type="checkbox"/> Lift Tables		
*Serial Number(s):		Invoice # (if available):
Dealer Name:		Sales Rep.:
Manual Verification *Manual Number:		

\*Indicates information that must be provided.

Please return to:

Pentalift Equipment Corporation  
P.O. Box 1510,  
Buffalo, NY 14240-1510

or

Pentalift Equipment Corporation  
21 Nicholas Beaver Rd  
Puslinch, Ontario N0B 2J0

Attention: Service Department

Or Fax to (519) 763-2894

# SAFETY INFORMATION AND WARNINGS



**READ THESE SAFETY PRACTICES BEFORE INSTALLING, OPERATING OR SERVICING THE PENTALOCK HFR32 VEHICLE RESTRAINT. FAILURE TO FOLLOW THESE SAFETY PRACTICES MAY RESULT IN PROPERTY DAMAGE, BODILY INJURY OR DEATH.**

THE OPERATION OF THIS EQUIPMENT IS SUBJECT TO CERTAIN HAZARDS THAT CAN BE PROTECTED AGAINST ONLY BY THE EXERCISE OF CARE AND COMMON SENSE AND NOT BY MECHANICAL MEANS. IT IS, THEREFORE, ESSENTIAL TO HAVE COMPETENT, QUALIFIED OPERATORS TRAINED IN THE SAFE OPERATION AND CARE OF THIS TYPE OF EQUIPMENT. ALL PERSONNEL MUST COMPLETELY UNDERSTAND THIS SAFETY INFORMATION BEFORE WORKING ON OR NEAR THIS EQUIPMENT.



**DANGER** indicates an imminently hazardous situation which, if not avoided, will result in death or serious injury.



**WARNING** indicates a potentially hazardous situation which, if not avoided, could result in death or serious injury.



**CAUTION**, used with the safety alert symbol, indicates a potentially hazardous situation which, if not avoided, could result in minor or moderate injury.



**NOTICE** is used to address practices not related to personal injury.



**Before doing any installation, maintenance, inspection or trouble shooting, barricade all areas from traffic around the work area inside (and outside if applicable) for safety and post appropriate warning signs.**



**Arc flash and shock hazard PPE (personal protection equipment) required. De-energize equipment before working on or inside. Do not open cover without appropriate PPE. Refer to NFPA 70E for PPE requirements. This panel may contain more than one power source. Hazardous voltage will cause severe injury or death.**



**Before doing any electrical work, be certain that the power is disconnected with a fused disconnect, properly tagged and locked out. Fused disconnect and lockout device (supplied and installed by others) must meet with all applicable codes and regulations. All electrical work must be performed by a qualified electrician in accordance with all applicable codes and regulations.**



**It is the responsibility of others to ensure the proper mounting of any wall mounted equipment such as remote power units, control panels and light packages and to ensure that the mounting surface is capable of fully supporting the loads generated by the equipment.**

1. **Do not load/unload any truck without visually confirming that the vehicle restraint has securely engaged the truck's R.I.G. (Rear Impact Guard) and the appropriate signal lights are illuminated as indicated by the operating instructions in the Owners Manual and on the control panel. If the vehicle restraint fails to engage the truck's R.I.G. for any reason, be certain to restrain the truck with appropriate alternate means and to follow the override procedures listed in this manual before proceeding with any loading/unloading.**
2. Never stand between the dock and a truck.
3. Stay clear of operating path at all times.
4. When not in use, the restraint must always be in the stored position.
5. Regular inspection and maintenance must be performed to keep the equipment in proper operating condition in accordance with the detailed instructions in this manual. (See the MAINTENANCE & LUBRICATION section of this manual on page 24)
6. Ensure that the equipment is not used by anyone if you believe that any part of it might be in disrepair (e.g. loose wires, leaking hoses, bent structural members, broken welds, etc.). See Warranty Section.
7. If you have any questions, contact your immediate supervisor or your authorized Pentlift representative for assistance.
8. Do not operate, use, maintain or install this equipment if you are impaired in any manner.

# OWNER RESPONSIBILITY

The Owner's Responsibilities include the following:

6.3.1 The owner should recognize inherent danger of the interface between dock and transport vehicle. The owner shall, therefore, train and instruct loading dock operating personnel in the proper use of restraining devices in accordance with information provided in Section 6.1.2.

6.3.2 Nameplates, cautions, instructions, posted warnings and communication lights shall not be obscured from the view of loading dock operating personnel or maintenance personnel for whom such warnings are intended (also see 6.1.3 and 6.3.5).

6.3.3 Manufacturer's recommended periodic maintenance and inspection procedures in effect at date of shipment shall be followed, and written records of the performance of these procedures should be kept.

6.3.4 Restraining devices that are structurally damaged shall be removed from service, inspected by the manufacturer's authorized representative, and repaired as needed before being placed back in service.

6.3.5 The manufacturer shall supply replacement nameplates, communication lights, caution or instructional labels, and operating and maintenance manuals upon request of the owner. The owner shall see that all nameplates, communication lights, and caution and instruction markings or labels, are in place and legible and that the appropriate operating and maintenance manuals are provided to users (see also 6.1.3 and 6.3.2).

6.3.6 Modifications or alterations of restraining devices shall be made only with written permission of the original manufacturer. These changes shall be in conformance with all applicable provisions of this standard and shall be at least as safe as the equipment was before modification. These changes shall also satisfy all safety recommendations of the original equipment manufacturer for the particular application of the restraint.

6.3.7 When industrial vehicles are driven on or off a transport vehicle during loading or unloading operation, the parking brakes on the transport vehicle shall be applied and wheel chocks or another vehicle restraint that provides equal or better protection shall be engaged. Also, whenever possible air-ride suspension systems should have the air exhausted prior to performing said loading or unloading operations.

6.3.8 When a vehicle restraint is unable to properly engage a transport vehicle, the user shall activate the applicable communication if so included, or provide an alternate method to address a "not restrained vehicle condition" to alert and or protect the loading dock operating personnel.

6.3.9 When selecting a restraining device, it is important to consider not only present requirements but also future plans or adverse environments.

6.3.10 The restraint should never be used in a manner not intended by its design. It must also be compatible with the loading dock equipment and other conditions relating to the loading dock area.

**NOTE:** The MH30 Committee recognizes the devices intended to secure a transport vehicle to a loading dock by mechanical means. The NHTSA Standard 49CFR ch.V 571.223 specifies the strength of the rear impact guard and 49 CFR Ch.V 571.224 specifies the size and locations of the rear impact guard. It is, therefore, recommended that users of such positive restraint devices review:

- The means of attachment to the transport vehicle
- The strength of the overall connection
- The proper coordination of the actuation of devices with any signaling system used
- The need to use wheel chocks



Unless specifically agreed to in writing by Pentalift Equipment Corporation at the time the equipment is ordered and prior to the equipment's manufacture, this equipment is sold as a complete package. It is not to be altered, changed or added to in any way or form, in its configuration and function, without the written permission of Pentalift Equipment Corporation.

If requested by a customer, Pentalift Equipment Corporation is not supplying all or some of the power unit and / or control components for the equipment's application. The power unit and controls constitute important safety and functional aspects of the equipment. It is the customer's responsibility to address the operational and safety issues associated with providing the required controls and power units to satisfy the operational and safety requirements of the equipment.

The customer's decision to supply all or some of these components indicates that the customer is taking full responsibility for any and all possible operational, safety and liability issues associated to the product and its configuration. The customer also agrees to absolve Pentalift Equipment Corporation from any and all possible operation, safety and liability issues.

# TABLE OF CONTENTS

PRODUCT REGISTRATION .....	I
SAFETY INFORMATION AND WARNINGS .....	II
OWNER RESPONSIBILITY .....	III
TABLE OF CONTENTS .....	1
SAFETY LABELING .....	2
INSTALLATION INSTRUCTIONS .....	3
WELDING REFERENCE INFORMATION .....	11
OPTIONAL EXTENSION PLATE INSTALLATION INSTRUCTIONS .....	12
INSTALLATION INSTRUCTIONS FOR OPTIONAL HORIZONTAL (SURFACE) MOUNTED RESTRAINT (MODEL HFR32SM) .....	14
ELECTRICAL INSTALLATION INSTRUCTIONS .....	17
OPERATION AND PERFORMANCE CHECK .....	19
OPERATING INSTRUCTIONS .....	21
DOCK VACANT / READY TO RECEIVE A VEHICLE .....	21
TRAILER IN POSITION .....	21
LOADING / UNLOADING COMPLETE .....	22
R.I.G CANNOT BE ENGAGED BY RESTRAINT .....	23
LOADING / UNLOADING COMPLETE .....	23
MAINTENANCE AND LUBRICATION .....	24
TROUBLE SHOOTING GUIDE .....	27
SETTING THE DOWN TRAVEL LIMIT SWITCH LOWERED POSITION: .....	30
RESTRAINT ADJUSTMENTS .....	30
SIGNAL BAR SWITCH ADJUSTMENTS .....	31
ADJUSTMENT OF RESTRAINT ENGAGE HEIGHT .....	32
REPLACEMENT PARTS .....	33
3 PHASE TRANSFORMER AND OVERLOAD .....	33
RESTRAINT REPLACEMENT PARTS LIST .....	35
CONTROL PANEL REPLACEMENT PARTS .....	36
SINGLE PHASE .....	36
THREE PHASE .....	37
SINGLE PHASE - COMBO PANEL .....	38
THREE PHASE OR 208V/240V SINGLE PHASE - COMBO PANEL .....	39
VERTICAL DOCK LEVELER .....	40
DELUXE OUTSIDE LIGHT REPLACEMENT PARTS .....	41
REPLACEMENT SIGNS .....	42
LIST OF ILLUSTRATIONS .....	43
PENTALIFT EQUIPMENT CORPORATION WARRANTY .....	44

# SAFETY LABELING

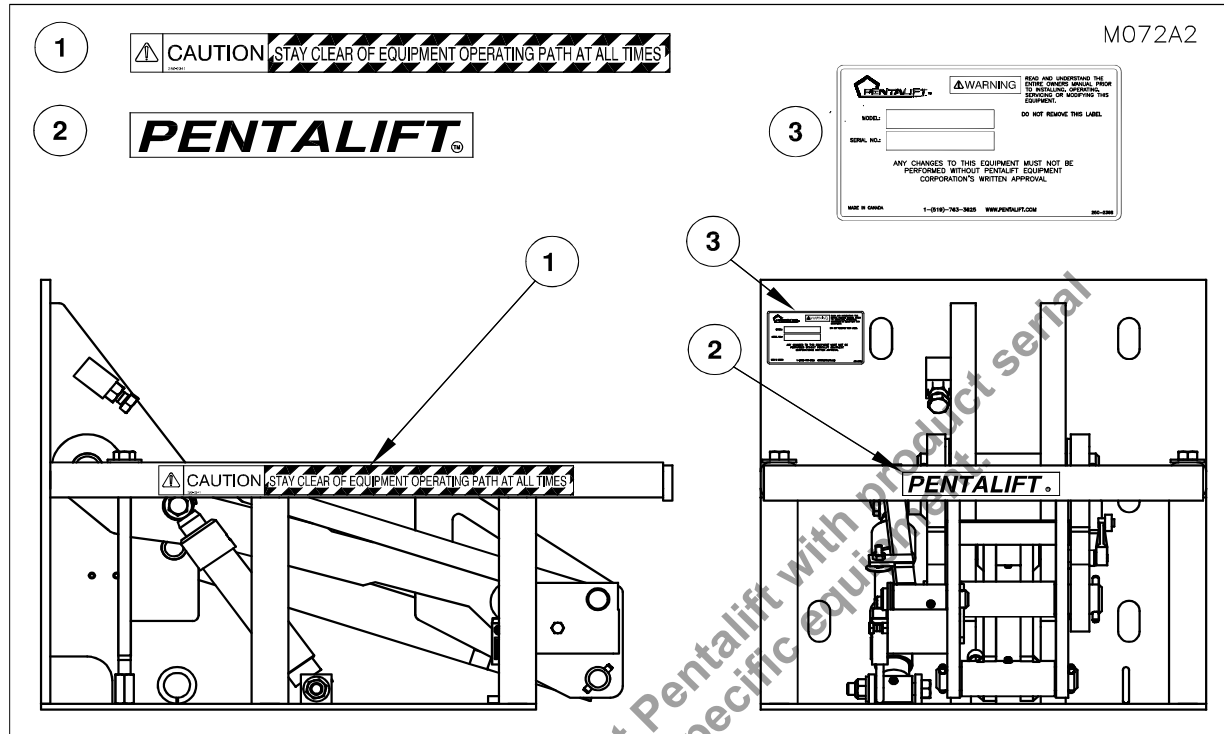

Figure 1: Safety Labeling

Be sure that all labeling is in place and intact when the unit is received. If any of the safety labels or decals are missing or illegible, contact your Pentalift representative for immediate replacement.

**NOTE:** In some instances, product configuration and / or product options may dictate that the product labels will not be placed as indicated on the drawing ("Figure 1: Safety Labeling"). Different label locations will be selected at the factory, when required, to avoid an impaired view of the labels. Note the label locations as supplied on the product, when it is received to accommodate future label replacement requirements.

**NOTE:** It is the owner's responsibility to ensure that all safety labeling remains legible and in its original position throughout the life of the product. It is also the owner's responsibility to ensure that all labels are and will continue to be readily visible to the operators and people working with or around the equipment. If visibility of any of label is compromised for any reason then; either 1) Rectify the situation to allow the label to be readily visible 2) Order replacement label(s) from Pentalift for installation in a location that does facilitate complete visibility. If any of the safety labels or decals are missing or illegible, contact your Pentalift representative for immediate replacement. Inspection shall be done during regular maintenance and lubrication (See Maintenance Section, page 24)

To re-order labels and decals, use the following part numbers:

<u>Item</u>	<u>Part No.</u>	<u>Description</u>
1	250-2341	"CAUTION Stay clear of equipment..."
2	250-1143	"Pentalift"
3	250-2368	Specification Plate

**NOTE:** State Model # and Serial # when ordering replacement parts.

# INSTALLATION INSTRUCTIONS



Do not install, operate or service this product unless you have read and fully understand the entire contents of this manual. Failure to do so may result in property damage, bodily injury or death.

**NOTE:** A very high level of field issues with this type of equipment can be directly attributed to improper or incomplete installation. The installation instructions and information provided for this equipment is thorough. A step by step sequence for installation is provided. All steps must be followed and completed to provide a complete installation. Incomplete or improper installations can lead to equipment malfunction and / or damage, create safety issues and void warranties. Please follow all installation and set ups steps as indicated in the installation instructions and owner's manual. If you are unclear or uncertain regarding any of the steps contact your Pentalift representative for clarification. A copy of the completed steps listing with the sign off and photos of the installation as indicated at the conclusion of the installation instructions will be required prior to any Pentalift factory trouble shooting assistance.

---

## IMPORTANT

### PREPARATION PRIOR TO INSTALLATION

---

Follow all installation instructions in the precise consecutive order that they are written. If the equipment cannot be installed in the order as outlined below, contact Pentalift Equipment Corporation for written instructions on how to proceed. Do not proceed with an alternate installation method unless written confirmation has been provided by Pentalift Equipment Corporation. To accommodate a complete installation there is a blank space provided beside each numbered step in the installation instructions. Please check off the steps sequentially as they are completed. This will assist in confirming a complete installation.



Before doing any installation, maintenance, inspection or trouble shooting, barricade all areas from traffic around the work area inside (and outside if applicable) for safety and post appropriate warning signs.



Arc flash and shock hazard PPE (personal protection equipment) required. De-energize equipment before working on or inside. Do not open cover without appropriate PPE. Refer to NFPA 70E for PPE requirements. This panel may contain more than one power source. Hazardous voltage will cause severe injury or death.



Before doing any electrical work, be certain that the power is disconnected with a fused disconnect, properly tagged and locked out. Fused disconnect and lockout device (supplied and installed by others) must meet with all applicable codes and regulations. All electrical work must be performed by a qualified electrician in accordance with all applicable codes and regulations.



MAKE SURE LIFTING AND SLINGING DEVICES ARE OF SUFFICIENT CAPACITY, USED IN THE CORRECT MANNER AND ARE IN GOOD WORKING ORDER. ALL LIFTING, POSITIONING AND INSTALLATION, AS WELL AS THE BREAK-IN AND PERFORMANCE CHECK MUST BE DONE BY QUALIFIED PERSONNEL TRAINED AND EXPERIENCED IN NECESSARY SAFETY PROCEDURES.



BE SURE ALL HYDRAULIC FITTINGS ARE RATED FOR HYDRAULIC SYSTEMS THAT MAY PEAK OUT AT 4000PSI. HARDWARE STORE ITEMS CAN BURST AT 150PSI. ONLY BUY REPLACEMENT PARTS FROM PENTALIFT.



It is the responsibility of others to ensure the proper mounting of any wall mounted equipment such as remote power units, control panels and light packages and to ensure that the mounting surface is capable of fully supporting the loads generated by the equipment.

## **WARNING**

THIS RESTRAINT IS DESIGNED TO OPERATE WITH THE FACE OF THE DOCK BUMPERS EXTENDED 4" PAST THE POSITION OF THE BACK PLATE OF THE RESTRAINT ONCE IT IS INSTALLED. THIS DIMENSION RELATIONSHIP IS CRITICAL TO ASSURING THE PROPER OPERATIONAL POSITIONING OF THE RESTRAINT. PRIOR TO COMMENCING WITH THE INSTALLATION, CONFIRM THAT THE ABOVE NOTED RELATIONSHIP BETWEEN THE DOCK BUMPER AND THE RESTRAINT WILL EXIST ONCE THE INSTALLATION IS COMPLETED. ONCE THIS IS CONFIRMED, COMMENCE THE INSTALLATION. IF THE PROPER RELATIONSHIP WILL NOT EXIST, A RESTRAINT INSTALLATION EXTENSION PLATE MAY BE REQUIRED. CONSULT YOUR AUTHORIZED REPRESENTATIVE FOR ASSISTANCE.

1. \_\_\_ Ensure concrete and anchor bolts have sufficient strength to meet the draw pull forces which will be applied simultaneously. (See "Figure 2: Draw Pull Forces" on page 4).
2. \_\_\_ Ensure that the required conduits are in place (see "Figure 8: Conduit / Outside Light / Outside Sign Locations" on page 11).
3. \_\_\_ Mark the centerline of the dock and the center line of the restraint back plate.
4. \_\_\_ Position the HFR32 by matching the centerline of the dock and the center line of the restraint back plate (See "Figure 3: Shim Locations" on page 5).

## **NOTICE**

THE RESTRAINT MUST BE AT FINISHED DRIVEWAY LEVEL AND FLUSH WITH THE FOUNDATION WALL.

5. \_\_\_ Remove the guard assembly from the restraint (See "Figure 4: Remove/Replace the Guard Assembly" on page 5).
6. \_\_\_ If the wall and/or ground are not square with respect to the back plate and the bottom plate of the restraint, metal shims must be inserted to prevent the back plate from twisting during lagging to the wall (See "Figure 3: Shim Locations" on page 5). Shims must be placed under the bottom plate below the hydraulic cylinder and at the front end of the bottom plate for proper support.
7. \_\_\_ If the dock face is equipped with a cast in weld plate, proceed to step 9. Otherwise, drill the required holes into the foundation wall, using the back plate of the restraint as a template.
8. \_\_\_ Recommended fasteners are  $\frac{3}{4}$ " diameter x minimum 7" long wedge anchors with a minimum shear value of 18,500 lbs (8,390kg), and a tension value of 16,400 lbs (7,440 kg). Torque to manufacturers specifications.
9. \_\_\_ If a weld plate has been pre-cast into the foundation, apply a  $\frac{3}{8}$ " fillet weld 3" long at 6" intervals around the two sides and the top of the back plate. Also, weld all slots in the back plate to the foundation weld plate. For more information, see WELDING REFERENCE INFORMATION on page 11 as well as "Figure 5: Weld Locations" on page 6.

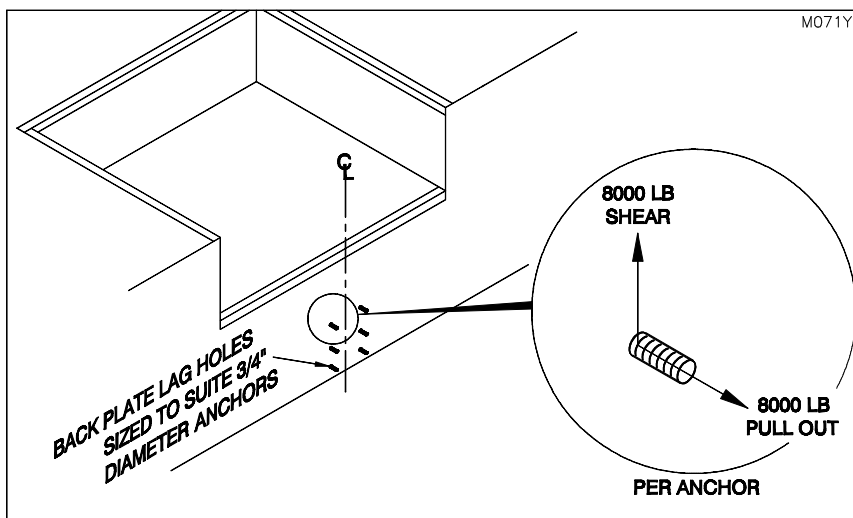

Figure 2: Draw Pull Forces

10. \_\_\_ Weld all shims in a stack to each other as well as to the back plate.

11. Mount the power unit horizontally with the reservoir breather facing up (See “Figure 6: Power Unit and Control Panel” on page 6). When mounting the power unit on a wall, position the power unit above the wall bracket keeping the ½” wall mount holes below the power unit. This ensures easier access to all the wall bracket holes when mounting the power unit (See “Figure 7: Wall Mounted Power Unit” on page 6). Note: The hydraulic power unit and the control panel are important components of the equipment. It is important that they be installed in a location that is free from dirt, debris and splashing and / or wash down. The location should also be free from the likelihood of impacts. Each application has different conditions and design features. Evaluation of the specific site conditions and parameters in conjunction with common sense should be used to determine the appropriate hydraulic power unit and control panel installation location. Confirm the hose(s) length is sufficient to accommodate the desired routing path from the equipment to the power unit.

**Note:** If restraint is not a standalone unit, meaning the restraint will be hydraulically driven by the dock leveler power unit, then refer to Figure “Figure 6B: DOCK LEVELER/RESTRAINT COMBO UNIT” on page 8, “Figure 6C: VERTICAL DOCK LEVELER/RESTRAINT COMBO UNIT” on page 9 , or “Figure 6D: 100K DOCK LEVELER/RESTRAINT COMBO UNIT” on page 10 for the appropriate hook up of the restraint to the leveler power unit.

**REFER TO THE DOCK LEVELER OWNER MANUAL FOR SUPPORTING THE DOCK LEVELER FOR MAINTENANCE.**

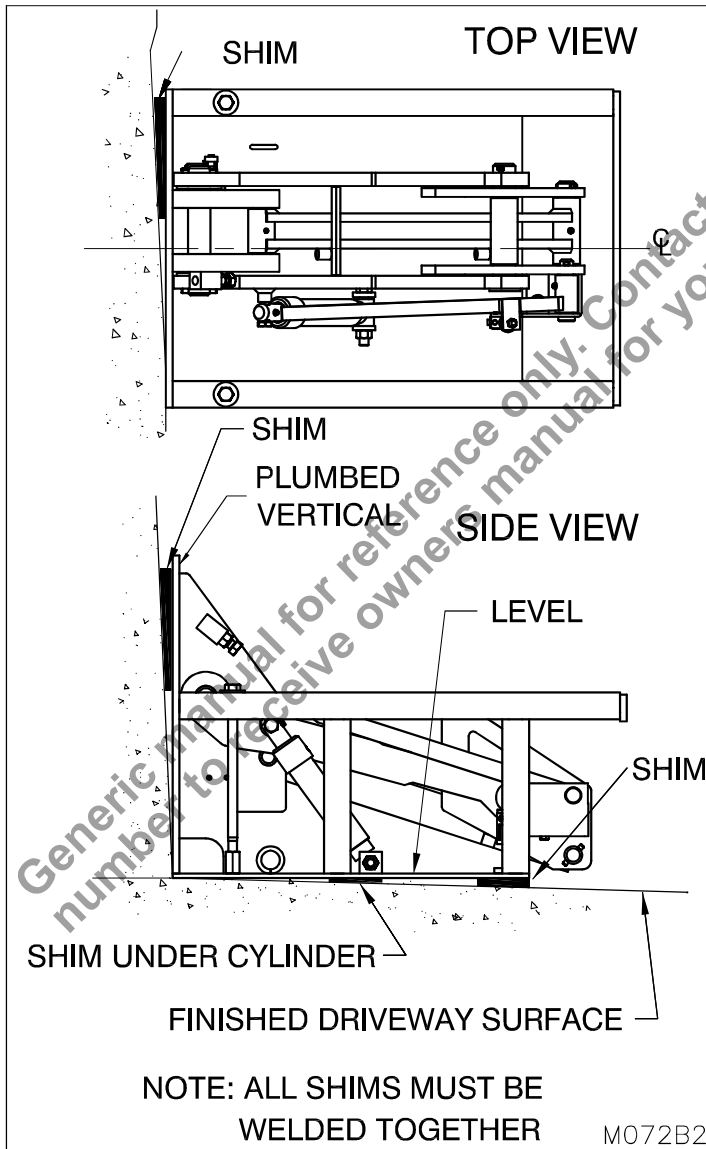

**Figure 3: Shim Locations**

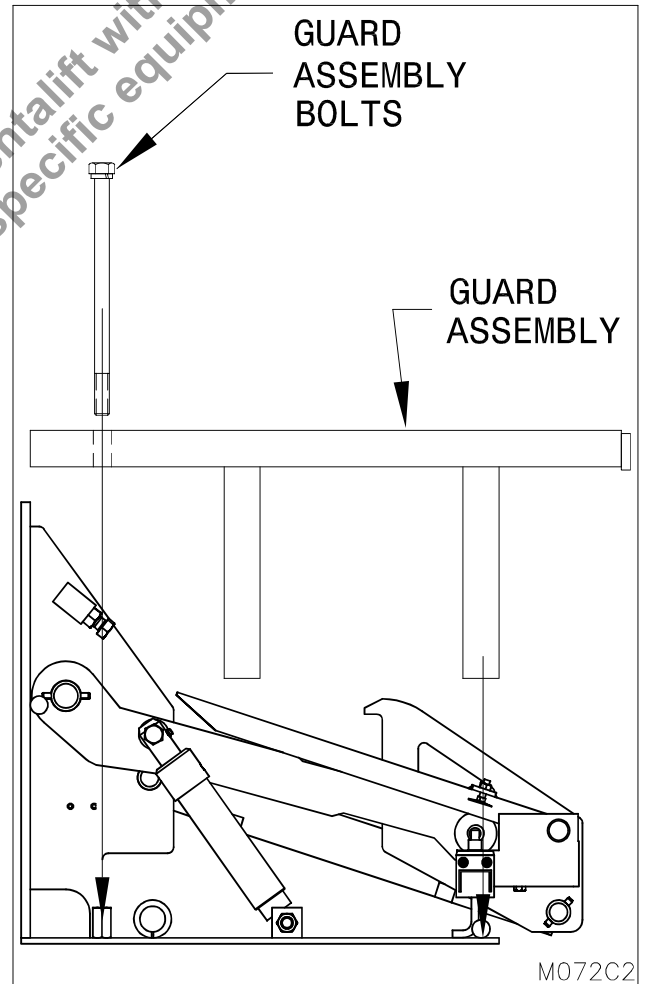

**Figure 4: Remove/Replace the Guard Assembly**

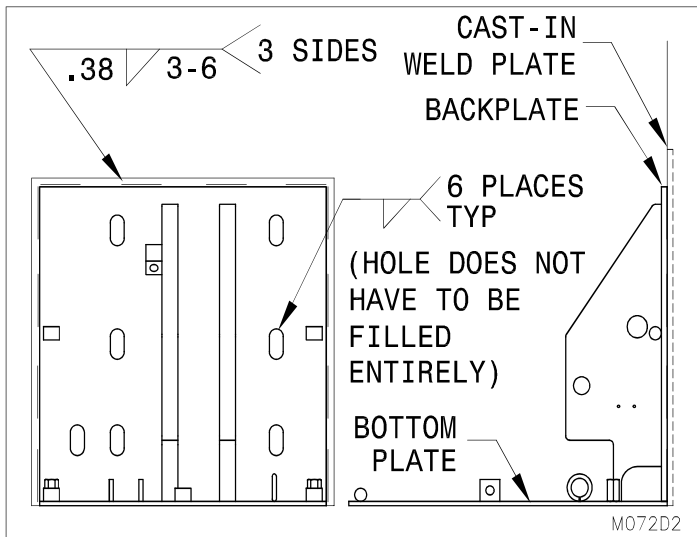

Figure 5: Weld Locations

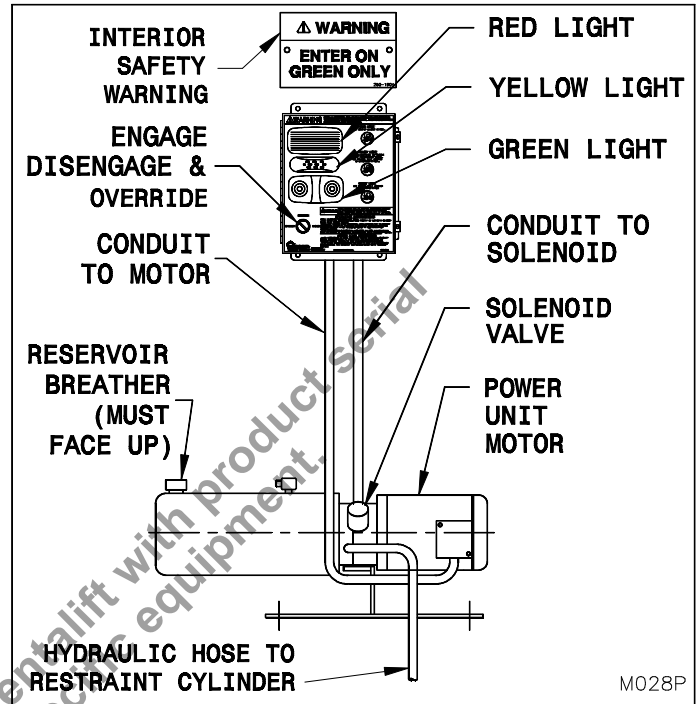

Figure 6: Power Unit and Control Panel

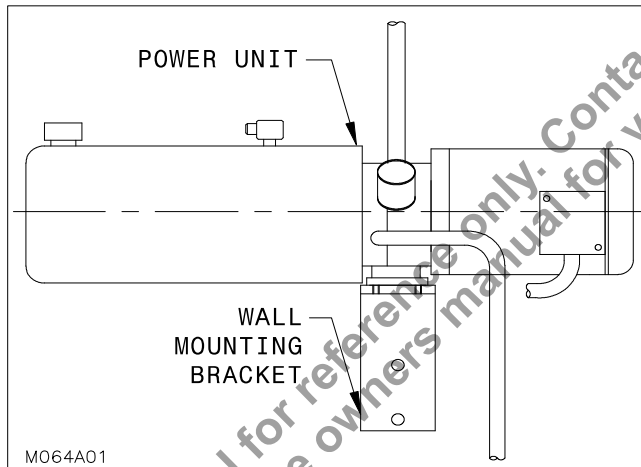

Figure 7: Wall Mounted Power Unit

12. \_\_\_ Feed the hydraulic hose through the conduit from the power unit to the cylinder on the restraint, connect and secure.
13. \_\_\_ Mount the outside light approximately 90" high from the finished driveway level (See "Figure 8: Conduit / Outside Light / Outside Sign Locations" on page 11).
14. \_\_\_ Mount the mirror image "Caution" sign above the outside light and normal vision "Caution" sign below the outside light.
15. \_\_\_ Connect all electrical lines as per the instructions on page 17 and the wiring diagram which is inside the electrical control panel.
16. \_\_\_ Lubricate all pivot points (See "MAINTENANCE AND LUBRICATION" on page 24).
17. \_\_\_ Clean and Paint Welds using Tremclad High Performance Rust Enamel (Gloss Dark Machine Grey) if unit is not zinc coated. If unit is zinc coated, use Tremclad Gloss Aluminum Rust paint.
18. \_\_\_ Re-install the Guard Assembly (See "Figure 4: Remove/Replace the Guard Assembly" on page 5).
19. \_\_\_ Test operation (See "OPERATION AND PERFORMANCE CHECK" on page 19).
20. \_\_\_ Check the raised height of the restraint and ensure that it is properly set. If adjustment is required follow the adjustment instructions. (See "ADJUSTMENT OF RESTRAINT ENGAGE HEIGHT" on page 32).
21. \_\_\_ Confirm that all steps of the installation instructions have been completed. Fill out the following information.

\_\_\_\_\_

**Installer Name (Print)**

\_\_\_\_\_

**Installer Signature**

\_\_\_\_\_

**Date Installation Completed**



**FAILURE TO PROPERLY INSTALL THE PENTALOCK HFR32 MAY RESULT IN PROPERTY DAMAGE, BODILY INJURY OR DEATH AND WILL VOID ALL WARRANTIES.**

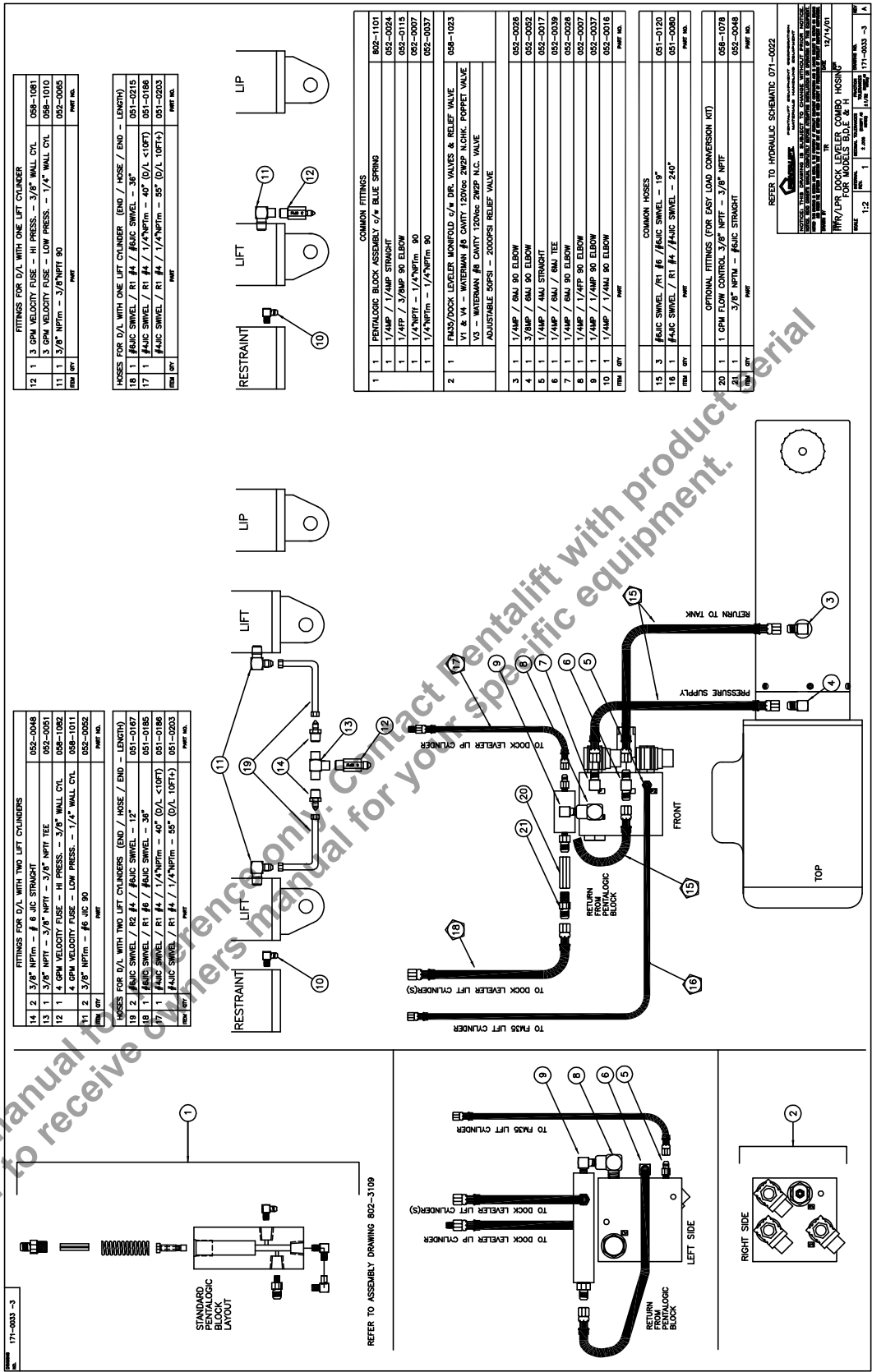

**Figure 6B: DOCK LEVELER/RESTRAINT COMBO UNIT**  
(Reference drawing 171-0033-3)

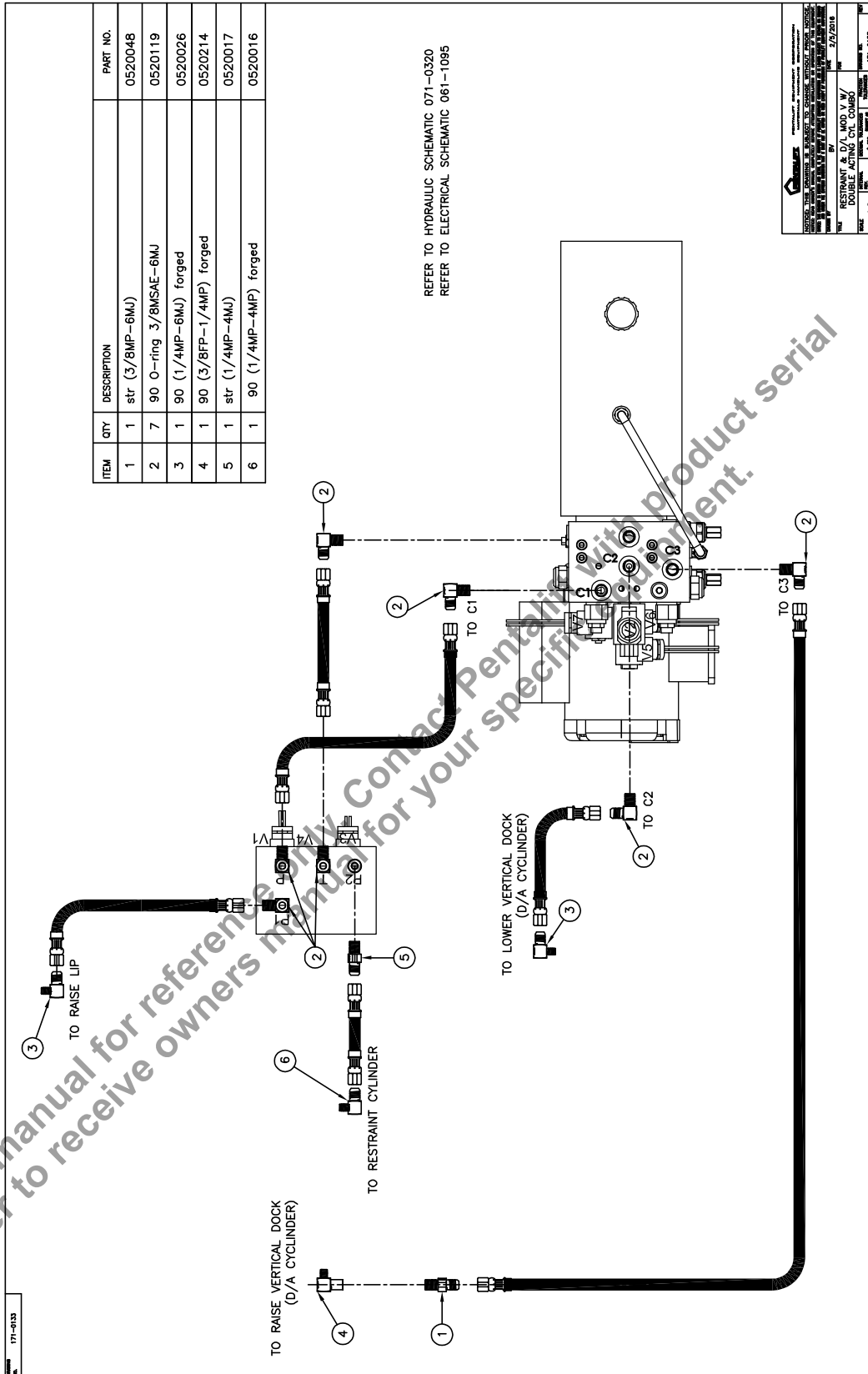

**Figure 6C: VERTICAL DOCK LEVELER/RESTRAINT COMBO UNIT**  
(Reference drawing 171-0133)



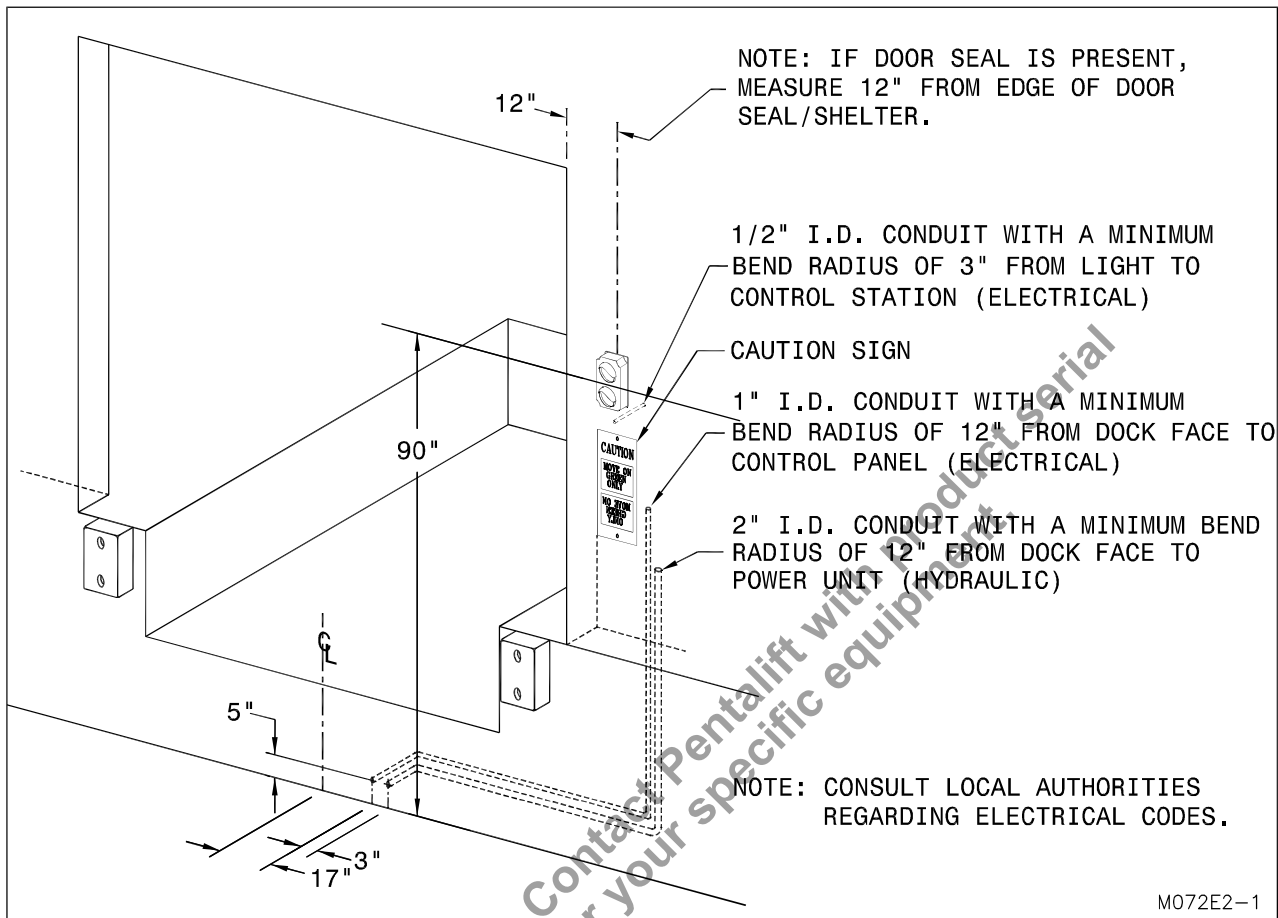

Figure 8: Conduit / Outside Light / Outside Sign Locations

## WELDING REFERENCE INFORMATION

- Observe and obey all welding safety requirements per AWS D1.1-92. (W117.2-74 in Canada.)
- Welding electrodes are to be clean and free from moisture.
- Material to be welded must be clean and free of oils, excessive millscale/rust etc.
- All craters are to be filled to a minimum of 85% of the cross sectional area of the weld.
- All under cutting is to be removed by either welding, grinding or a combination of both.
- Maximum reinforcement on butt welds is 1/8".
- Use highest current possible per chart below to obtain satisfactory weld.

Electrode	E7018	
Diameter	1/8"	5/32"
Amperage	130-150	140-180

## OPTIONAL EXTENSION PLATE INSTALLATION INSTRUCTIONS



Before doing any installation, maintenance, inspection or trouble shooting, barricade all areas from traffic around the work area inside (and outside if applicable) for safety and post appropriate warning signs.



THIS RESTRAINT IS DESIGNED TO OPERATE WITH THE FACE OF THE DOCK BUMPERS EXTENDED 4" PAST THE POSITION OF THE BACK PLATE OF THE RESTRAINT ONCE IT IS INSTALLED. THIS DIMENSION RELATIONSHIP IS CRITICAL TO ASSURING THE PROPER OPERATIONAL POSITIONING OF THE RESTRAINT. THE OPTIONAL EXTENSION IS REQUIRED ONLY WHEN THIS RELATIONSHIP BETWEEN THE DOCK BUMPER AND THE RESTRAINT WILL NOT EXIST ONCE THE INSTALLATION IS COMPLETED. ONCE IT IS CONFIRMED THAT A RESTRAINT INSTALLATION EXTENSION PLATE IS REQUIRED, FOLLOW THESE INSTRUCTIONS TO INSTALL IT PROPERLY. (CONSULT YOUR AUTHORIZED PENTALIFT REPRESENTATIVE FOR ASSISTANCE IN ACQUIRING THE CORRECT EXTENSION)

1. \_\_\_ Ensure that the required conduits are in place (See "Figure 8: Conduit / Outside Light / Outside Sign Locations" on page 11).
2. \_\_\_ Ensure concrete has sufficient strength to meet the draw pull forces which will be applied (See "Figure 2: Draw Pull Forces" on page 4).
3. \_\_\_ Mark the center line of the dock, the center line of the restraint back plate between the mounting holes and the center line of the extension back plate.
4. \_\_\_ If a cast in weld plate has been installed in the dock face, proceed to instruction 9.
5. \_\_\_ Center the extension back plate on the center line of the dock.
6. \_\_\_ If required, shim behind the extension back plate (as shown in "Figure 9: Extension Shim Locations" on page 12) to ensure the extension back plate is plumb and flush with the foundation wall.
7. \_\_\_ Drill required holes into the foundation using the extension plate as a template.

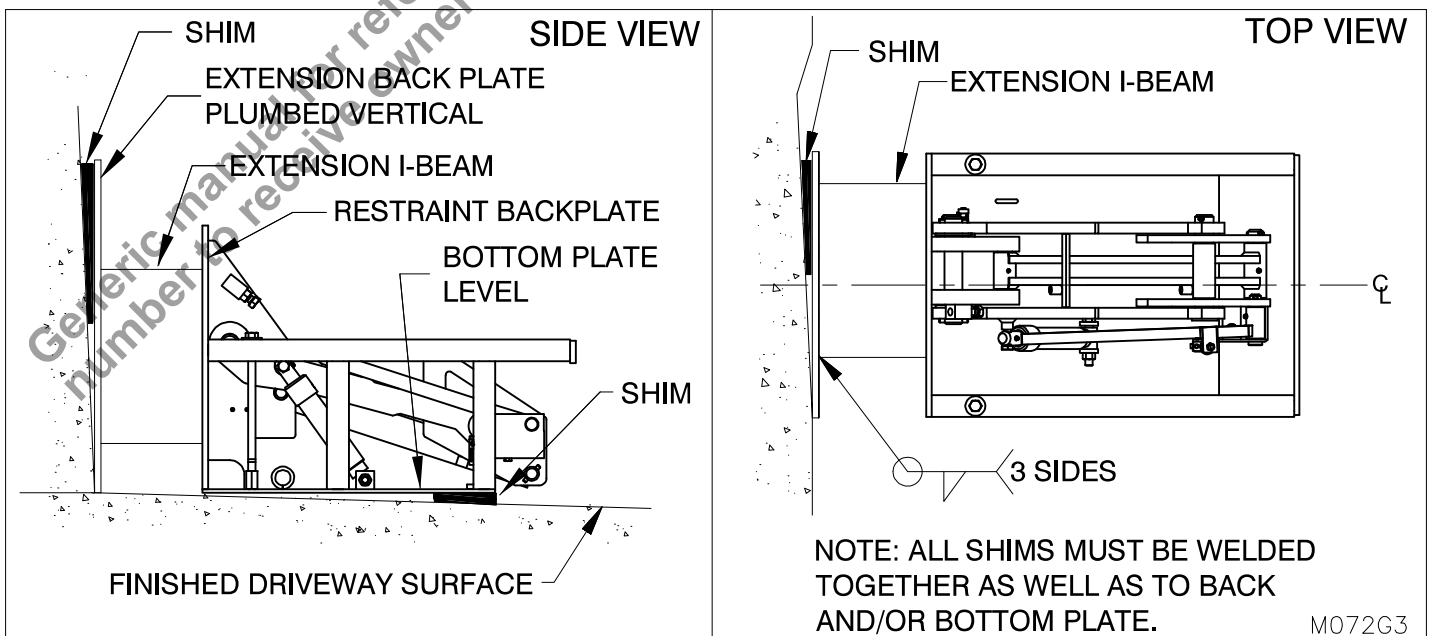
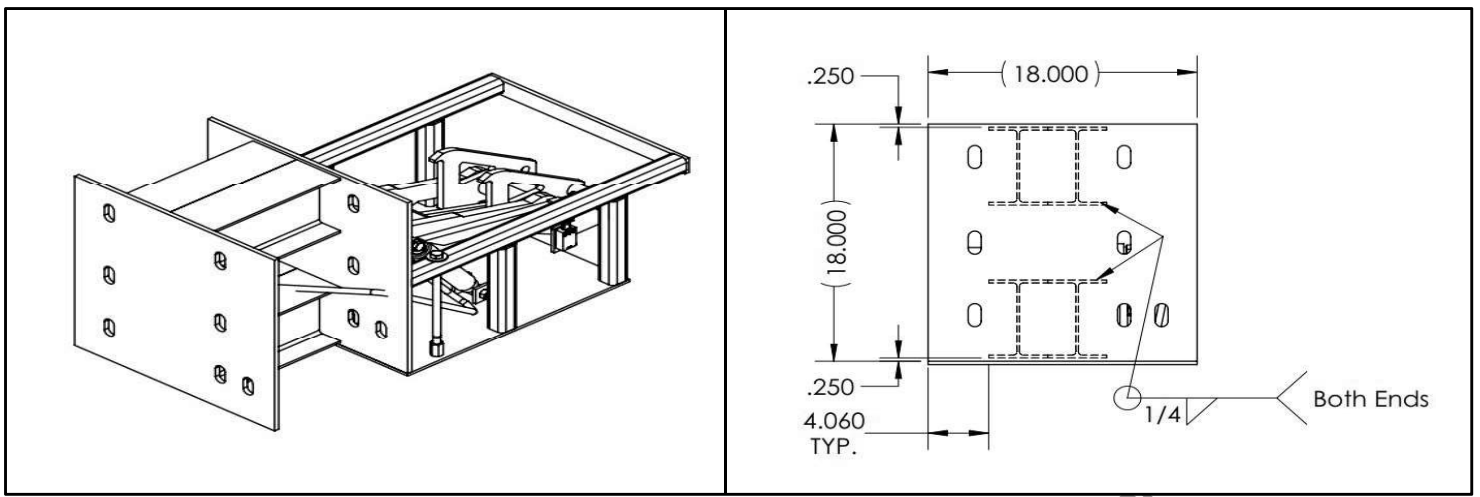

Figure 9: Extension Shim Locations



**Figure 10: Optional Extension**

8. \_\_\_ Recommended fasteners are 3/4" diameter x minimum 7" long wedge anchors with a minimum shear value of 18,500 lbs (8,390 kg), and tension value of 16,400 lbs (7,440 kg). Torque to manufacturers' specifications.
9. \_\_\_ Weld the I - beams to the restraint backplate, as shown in "Figure 10A: Optional Extension" on page 13, and weld using a minimum 1/4" leg on the welds and 2" long welds on 4" centers. (Refer to the "WELDING REFERENCE INFORMATION" on page 11)
10. \_\_\_ Position the restraint, complete with I - beams, centered vertically and horizontally to the extension plate.
11. \_\_\_ If required, shim beneath the restraint as shown in "Figure 9: Extension Shim Locations" on page 12.
12. \_\_\_ Weld the I - beams to the extension back plate (or cast-in weld plate) using the same weld specifications as noted for welding the I - beams to the back plate of the restraint in "Figure 10: Optional Extension" on page 13.
13. \_\_\_ Weld all shims in a stack to each other as well as to the back plate and/or bottom plate.
14. \_\_\_ Lubricate all pivot points (See "MAINTENANCE AND LUBRICATION" on page 24).
15. \_\_\_ Clean and paint welds using Tremclad High Performance Rust Enamel (Gloss Dark Machine Grey) if unit is not zinc coated. If unit is zinc coated, use Tremclad Gloss Aluminum Rust paint.
16. \_\_\_ Test operation (See "OPERATION AND PERFORMANCE CHECK" on page 19).
17. \_\_\_ Check the raised height of the restraint and ensure that it is properly set. If adjustment is required follow the adjustment instructions. (See "ADJUSTMENT OF RESTRAINT ENGAGE HEIGHT" on page 32).
18. \_\_\_ Confirm that all steps of the installation instructions have been completed. Fill out the following information.

\_\_\_\_\_  
**Installer Name (Print)**

\_\_\_\_\_  
**Installer Signature**

\_\_\_\_\_  
**Date Installation Completed**

# INSTALLATION INSTRUCTIONS FOR OPTIONAL HORIZONTAL (SURFACE) MOUNTED RESTRAINT (MODEL HFR32SM)

If the intent is to surface mount the vehicle restraint on a horizontal surface (typically the loading dock driveway) without attaching it to the loading dock wall face, the first step is to confirm the restraint has been ordered and provided to accommodate surface mounting. Note the standard HFR32 is not suitable for surface mounting (without attachment to the loading dock wall face) and must be ordered and built optionally to the model HFR32SM to accommodate surface mounting. To confirm, review the vehicle restraint serial number plate. The model number should be indicated as HFR32SM. Also confirm the gussets, side lagging brackets and holes in the horizontal base plate are present as shown (see “Figure 11: Horizontal Surface Mounting Installation” on page 16).



Before doing any installation, maintenance, inspection or trouble shooting, barricade all areas from traffic around the work area inside (and outside if applicable) for safety and post appropriate warning signs.



THIS RESTRAINT IS DESIGNED TO OPERATE WITH THE FACE OF THE DOCK BUMPERS EXTENDED 4" PAST THE POSITION OF THE BACK PLATE OF THE RESTRAINT ONCE IT IS INSTALLED. THIS DIMENSION RELATIONSHIP IS CRITICAL TO ASSURING THE PROPER OPERATIONAL POSITIONING OF THE RESTRAINT.

**Important note:** A horizontal surface mounting option creates the ability for the vehicle restraint to be installed on horizontal surface only without the requirement of being installed to a vertical support surface. This support surface is typically the driveway in front of the loading dock. The dimensional location of the vehicle restraint on the loading dock is critical in maximizing the restraints functionality and ability to properly restrain truck and trailers. When installing the vehicle restraint with surface mounting option, install the restraint so that it is centered laterally on the loading dock door and in a location from the dock face so that the back plate of the restraint is located 4" behind the face of the loading dock bumpers.

As well, confirm the installation surface in combination with the lag bolts (supplied by others) to be used for the installation has suitable strength to accept the forces as indicated in “Figure 11: Horizontal Surface Mounting Installation” on page 16. Note: Asphalt is typically not a suitable surface. Typically concrete of a sufficient depth and strength is required to accommodate the forces and loads as indicated.

If you are not certain in accommodating these requirements do not proceed with the installation.

1.  Inspect the HFR32SM. Confirm that the HFR32SM is configured for surface mounting. The optional horizontal surfacing mounting option consists of a series of holes in the bottom plate to accommodate the lagging as well as additional gusseting (see “Figure 11: Horizontal Surface Mounting Installation” on page 16)
2.  If there is damage to the restraint, rectify the damage by contacting the manufacturer. If there is no damage, proceed with the installation.
3.  Clean surface mounting area of all debris.
4.  Mark the center line of the dock leveler and the center line of the HFR32SM.
5.  Center the HFR32SM with the centerline of the dock leveler.
6.  Orient the restraint at the appropriate distance that places the back of the restraint 4" behind the front face of the loading dock bumper.
7.  Use a level to ensure that the HFR32SM is level side to side and front to back. Shimming may be required. All shims must be welded together and to the bottom of the HFR32SM. It is critical to ensure that the bottom of the HFR32SM make full contact with the supporting surface or grade especially underneath the gussets and hydraulic cylinder as indicated “Figure 11: Horizontal Surface Mounting Installation” on page 16. Make sure no voids exist under these areas.

8.  Lag the HFR32SM to the supporting surface using 3/4" diameter lag bolts (minimum shear force: 5,000 lbf; minimum tension value of 4,000 lbf). **Note: Lagging bolts are supplied by others. The lag bolt must provide the indicated tension and shear values. Follow the lag bolt manufacturer's instructions for installation as well as shear and tension values. Confirm the installation location is constructed to withstand the specified forces for the lag bolts. (see "Figure 11: Horizontal Surface Mounting Installation" on page 16)**
9.  Clean and paint welds using Tremclad High Performance Rust Enamel (Gloss Dark Machine Grey) if unit is not zinc coated. If unit is zinc coated, use Tremclad Gloss Aluminum Rust paint.
10.  Confirm that all steps of the installation instructions have been completed. Fill out the following information.

Generic manual for reference only. Contact Pentalift with product serial number to receive owners manual for your specific equipment.

\_\_\_\_\_  
**Installer Name (Print)**

\_\_\_\_\_  
**Installer Signature**

\_\_\_\_\_  
**Date Installation Completed**

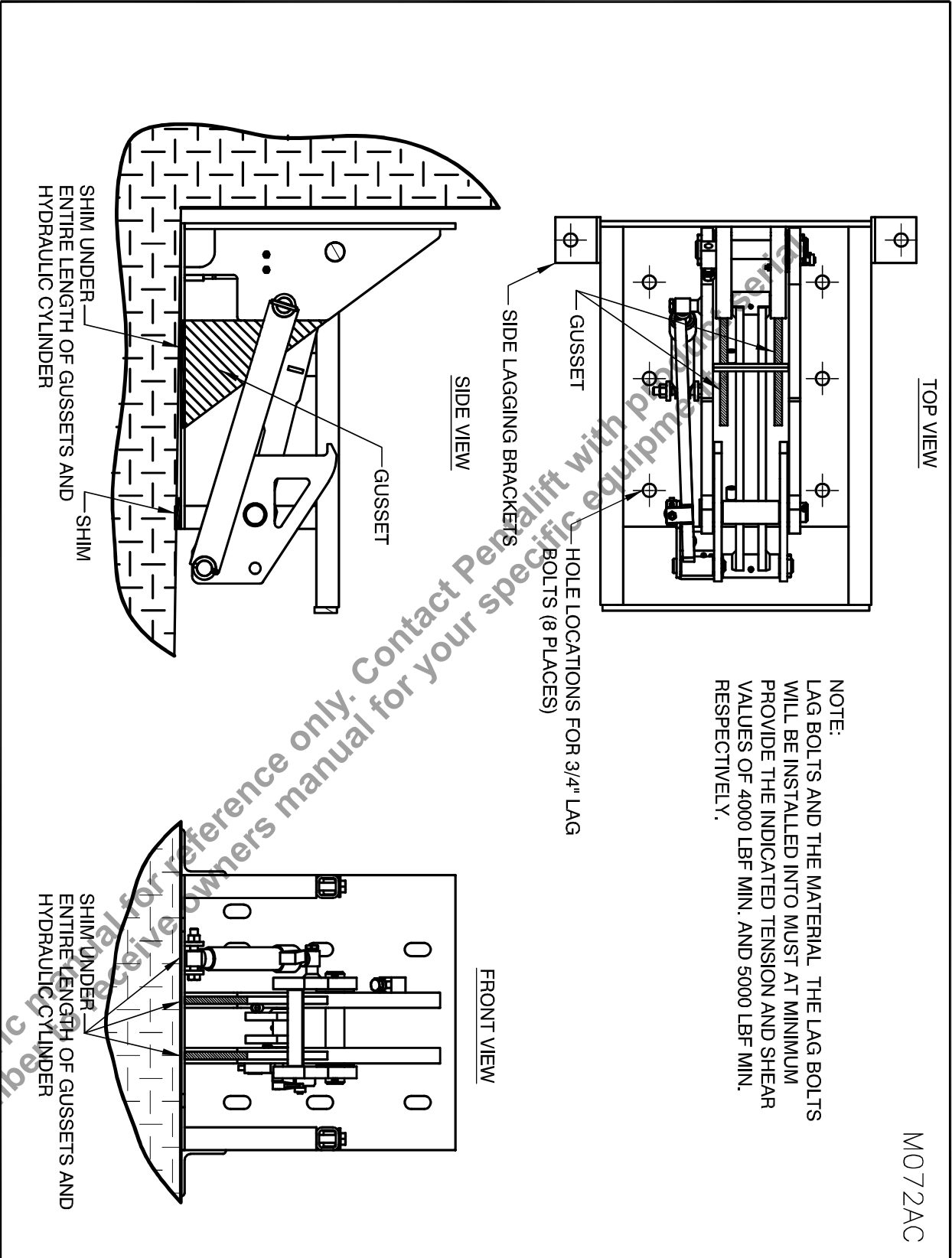

Figure 11: Horizontal Surface Mounting Installation

## ELECTRICAL INSTALLATION INSTRUCTIONS

The Pentalock HFR32 system is supplied in four separate main components consisting of the power unit, control panel, outside lights and the restraint. Each component is internally wired at the factory. They must all be connected to each other on site.

### **⚠ DANGER**

- **WIRING MUST BE DONE BY A QUALIFIED ELECTRICIAN.**
- **ALWAYS USE APPROPRIATE LOCK-OUT PROCEDURES DURING ANY ELECTRICAL INSTALLATIONS.**
- **ENSURE SUPPLY VOLTAGE IS CORRECT.**
- **ON 3 PHASE UNITS ENSURE PHASE POLARITY IS CORRECT. INCORRECT POLARITY WILL CAUSE THE MOTOR TO RUN BACKWARDS RESULTING IN CAVITATION AND POSSIBLE DAMAGE TO THE PUMP.**
- **ALWAYS OBSERVE ALL APPLICABLE ELECTRICAL CODES.**

### **⚠ DANGER**

Arc flash and shock hazard PPE (personal protection equipment) required. De-energize equipment before working on or inside. Do not open cover without appropriate PPE. Refer to NFPA 70E for PPE requirements. This panel may contain more than one power source. Hazardous voltage will cause severe injury or death.

### **⚠ DANGER**

Before doing any electrical work, be certain that the power is disconnected with a fused disconnect, properly tagged and locked out. Fused disconnect and lockout device (supplied and installed by others) must meet with all applicable codes and regulations. All electrical work must be performed by a qualified electrician in accordance with all applicable codes and regulations.

The following instructions apply to standard units:

1. \_\_\_ Run 7 wires or one 8-conductor cable rated SJ or SOW (minimum 18 AWG – check all applicable codes) from the control panel to a water proof junction box on the outside wall (junction box by others).
2. \_\_\_ Attach wires to the control panel. Carefully compare to the wiring schematic (located inside the control panel) to make sure that all limit switches are wired properly.
3. \_\_\_ Run two 4-conductor cables, one from each of the two limit switches on the vehicle restraint, to the waterproof junction box (supplied by others) and connect to the appropriate leads.
4. \_\_\_ Run 3 wires (minimum 18 AWG – check all applicable codes) from the control panel terminal strip to the outside signal lights.
5. \_\_\_ For units equipped with a motor starter assembly, ensure that the thermal overload is set to match the full load current as shown on the motor name plate. Confirm motor full load amps and size the supply cable accordingly, starting with 12 AWG as a minimum.
6. \_\_\_ Connect the motor power leads to the overload/starter assembly for 208-230V 1 phase or 3 phase units. For stand alone units with 120V 1 phase, the motor neutral connects to the terminal “N” and the hot connects to Terminal “6”.
7. \_\_\_ Connect the AC Power supply.

**NOTE: Power unit requires full voltage at motor. Wire size should be sufficiently sized to prevent line voltage drop when the motor is under load.**

8. \_\_\_ Fully raise and lower the unit a minimum of 10 times and check the performance of the switches and lights to ensure correct operation. (See “OPERATION AND PERFORMANCE CHECK” on page 19)

9. \_\_\_ Clean and paint welds using Tremclad High Performance Rust Enamel (Gloss Dark Machine Grey) if unit is not zinc coated. If unit is zinc coated, use Tremclad Gloss Aluminum Rust paint.
10. \_\_\_ Lubricate all pivot points. (See "MAINTENANCE AND LUBRICATION" on page 24)
11. \_\_\_ Re-install guard assembly on restraint. (See "Figure 4: Remove/Replace the Guard Assembly" on page 5)
12. \_\_\_ Unit is ready to operate. Test operation to ensure unit is operating properly.
13. \_\_\_ Confirm that all steps of the installation instructions have been completed. Fill out the following information.

\_\_\_\_\_  
**Installer Name (Print)**

\_\_\_\_\_  
**Installer Signature**

\_\_\_\_\_  
**Date Installation Completed**



**FAILURE TO PROPERLY INSTALL THE PENTALOCK HFR32 MAY RESULT IN PROPERTY DAMAGE, BODILY INJURY OR DEATH AND WILL VOID ALL WARRANTIES.**

*Generic manual for reference only. Contact Pentallift with Pentalift number to receive owners manual for your specific equipment.*

## OPERATION AND PERFORMANCE CHECK



Before doing any installation, maintenance, inspection or trouble shooting, barricade all areas from traffic around the work area inside (and outside if applicable) for safety and post appropriate warning signs.



Arc flash and shock hazard PPE (personal protection equipment) required. De-energize equipment before working on or inside. Do not open cover without appropriate PPE. Refer to NFPA 70E for PPE requirements. This panel may contain more than one power source. Hazardous voltage will cause severe injury or death.



Before doing any electrical work, be certain that the power is disconnected with a fused disconnect, properly tagged and locked out. Fused disconnect and lockout device (supplied and installed by others) must meet with all applicable codes and regulations. All electrical work must be performed by a qualified electrician in accordance with all applicable codes and regulations.



**FAILURE TO CONFIRM THE CORRECT OPERATION OF THE VEHICLE RESTRAINT IN ACCORDANCE WITH THESE INSTRUCTIONS MAY RESULT IN PROPERTY DAMAGE, BODILY INJURY OR DEATH.**

**NOTE:** A very high level of field issues with this type of equipment can be directly attributed to improper or incomplete installation. The installation instructions and information provided for this equipment is thorough. A step by step sequence for installation is provided. All steps must be followed and completed to provide a complete installation. Incomplete or improper installations can lead to equipment malfunction and / or damage, create safety issues and void warranties. Please follow all installation and set ups steps as indicated in the installation instructions and owner's manual. If you are unclear or uncertain regarding any of the steps contact your Pentalfit representative for clarification. A copy of the completed steps listing with the sign off and photos of the installation as indicated at the conclusion of the installation instructions will be required prior to any Pentalfit factory trouble shooting assistance.

**NOTE: IN SOME CASES THERE IS A CONSIDERABLE AMOUNT OF TIME BETWEEN THE SHIPMENT DATE AND USE OF YOUR VEHICLE RESTRAINT. THIS INITIAL BREAK-IN AND PERFORMANCE CHECK SHOULD BE PERFORMED BEFORE YOU BEGIN REGULAR USE OF YOUR VEHICLE RESTRAINT TO ENSURE THAT IT IS OPERATING PROPERLY.**

1. Confirm the down travel and signal bar switches are set up properly (see "Figure 22: Setting the Down Travel Limit Switch" on page 30 and "Figure 23: Setting the Signal Bar Limit Switch" on page 31).
2. Confirm restraint engage height adjust as instructed in "ADJUSTMENT OF RESTRAINT ENGAGE HEIGHT" on page 32.
3. Ensure the vehicle restraint has been returned to the **STORED** position (hook fully lowered). The **inside RED** light and the **outside GREEN** light must be illuminated.
4. Turn the selector switch to the "**ENGAGE**" position. The Restraint must move to the **FULLY** raised position. The **inside red** light must be illuminated while the **outside red** light is also illuminated and the audible alarm must be sounding. (See "Figure 17: Inside Light Red and Alarm Sounding" on page 23)
5. Return the vehicle restraint to the **STORED** position by turning the selector switch to the "**DISENGAGE**" position.
6. Turn the selector switch to the "**ENGAGE**" position. The vehicle restraint will begin to rise. While the vehicle restraint is rising (before it gets to the end of the upward travel) depress the signal bar. The upward movement of the vehicle restraint movement should stop and **inside green** light should illuminate while the **inside red and yellow** lights are off. Allow the signal bar to move to the normal (inactivated) position for a short distance by lifting hand off it slightly. Confirm the restraint rises and the buzzer sounds until the signal bar is again depressed. **Note:** An optional delay buzzer is available for the vehicle restraint. This delay option will cause a delay in the buzzer sounding for up to 2 seconds after the signal bar is no longer depressed.

7. **Depress and hold the signal bar** (See “Figure 23: Setting the Signal Bar Limit Switch” on page 31). This will simulate a truck’s R.I.G. The **inside GREEN** light must be illuminated. The **outside RED** light must be illuminated and the audible alarm must turn off.
8. To test the **OVERRIDE** feature, ensure the signal bar is not depressed and follow the entire sequence outlined in Step 2. With the restraint in the fully raised position and with the audible alarm sounding, turn the selector switch to the “**OVERRIDE**” position. The hooking arm will automatically return to the lowered position, and the audible alarm will be silenced. The **outside RED** light must be illuminated and the **inside YELLOW** light must be illuminated. (See Figure 17 and Figure 18, page 23).
9. Replace any burnt out light bulbs on the control panel or defective LED modules immediately.
10. Lubricate all pivot points as outlined in the MAINTENANCE & LUBRICATION Section on page 24.

The above steps describe and confirm the correct operation of this important piece of safety equipment. If the unit you have does not meet the requirements listed above, discontinue its use and/or repair it immediately. See the Troubleshooting section to correct problems. Contact your Pentalift representative for any required assistance.

Generic manual for reference only. Contact Pentalift with product serial number to receive owners manual for your specific equipment.

# OPERATING INSTRUCTIONS



Use by untrained people can result in property damage, bodily injury or death. Read, know, and obey all operating instructions and safety information. Follow all OSHA regulations regarding the use of this equipment. Do not use the vehicle restraint if any part of it looks broken or if it does not seem to operate properly. If repairs are needed, contact your pentalift representative.

**NOTE:** It is common for this product to be supplied in combination with other Pentalift Products. When the product supplied with other Pentalift products it is quite common for a combination control panel to be provided. The combination control panel will be a single control panel from which more than one product will be controlled and operated. If your installation incorporates the use of such a common control panel then read and follow all the instructions on the panel. If the instructions on the control panel conflict with instructions in this manual then follow the instructions on the control panel.

## DOCK VACANT / READY TO RECEIVE A VEHICLE

With the selector switch set at “**DISENGAGE**” Position the inside control panel red light is illuminated and the outside green light is illuminated, indicating that the dock is ready for truck arrival or departure.

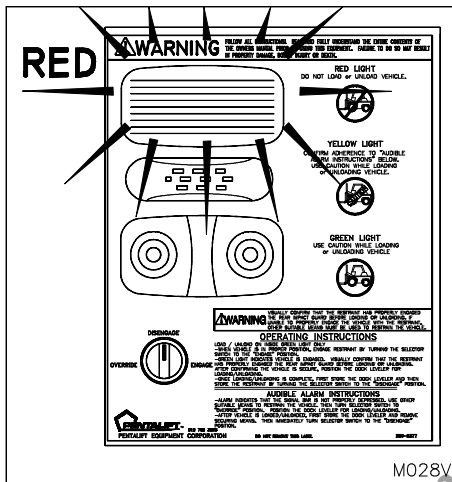

Figure 12: Inside Red Light

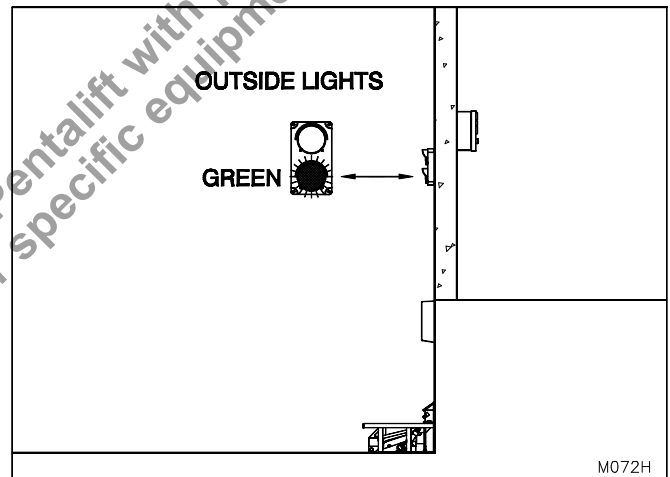

Figure 13: Restraint Lowered

## TRAILER IN POSITION

With the trailer centered in front the loading dock and parked tight against both dock bumpers, the operator turns the SELECTOR SWITCH TO “**ENGAGE**” POSITION. The outside red light will illuminate and the restraint will rise until the signal bar makes contact with the truck’s R.I.G. (if audible alarm sounds see “**R.I.G. CANNOT BE ENGAGED BY RESTRAINT**” on page 23). With the R.I.G. properly engaged, the inside control panel green light illuminates. Visually

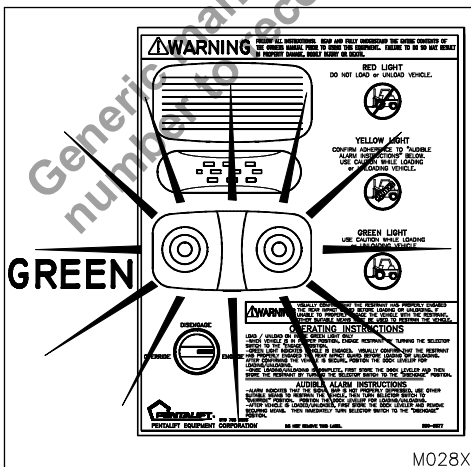

Figure 14: Inside Green Light

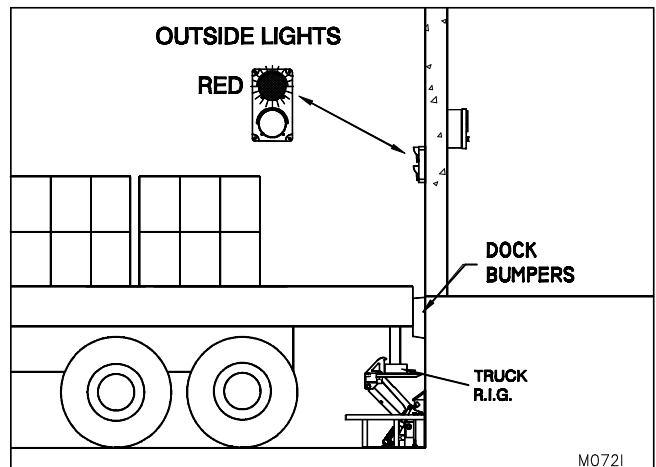

Figure 15: Vehicle in Position

confirm that the restraint has properly engaged the rear impact guard before loading or unloading. If unable to properly engage the vehicle with the restraint, other suitable means must be used to restrain the vehicle.

## LOADING / UNLOADING COMPLETE

When loading/unloading is complete, turn the SELECTOR TO SWITCH TO “**DISENGAGE**” POSITION. Illumination of the lights will reverse (inside red and the outside green will illuminate) and the truck is free to depart.

Generic manual for reference only. Contact Pentalift with product serial number to receive owners manual for your specific equipment.

## R.I.G CANNOT BE ENGAGED BY RESTRAINT

If the restraint fails to properly engage the R.I.G. an AUDIBLE ALARM WILL SOUND. Both the inside light and the outside light will remain red. Confirm that the trailer is centered with the loading dock and parked tight against both bumpers; and that the R.I.G. is not damaged, missing or located too far toward the rear trailer axle for the restraint to properly engage it.

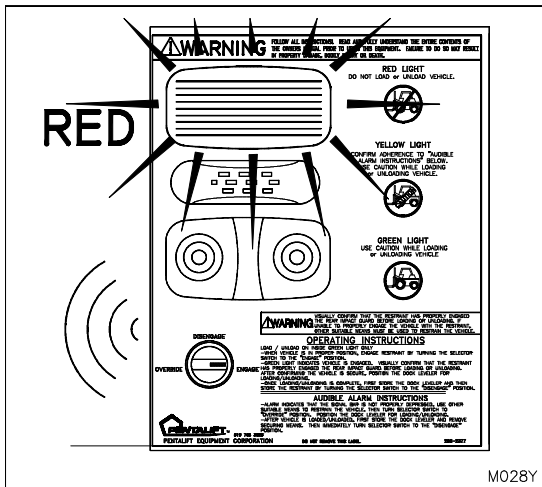

Figure 17: Inside Light Red and Alarm Sounding

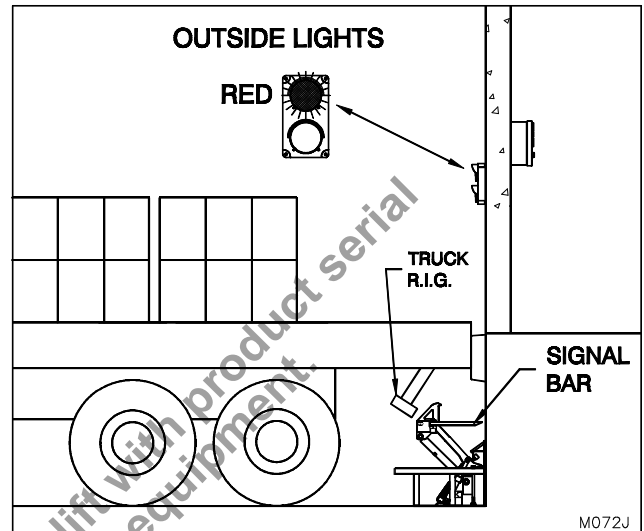

Figure 16: R.I.G. Not Secure

If engagement by the restraint is not possible, SECURE THE TRAILER BY OTHER MEANS. Turn the SELECTOR SWITCH TO THE “**VERRIDE**” POSITION. The outside red light will remain red, the inside yellow light will illuminate. The inside red light and audible alarm will turn off. The restraint will return to its lowered position.

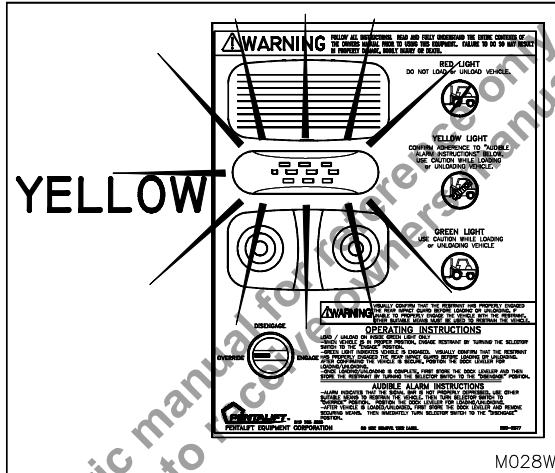

Figure 18: Inside Light Yellow

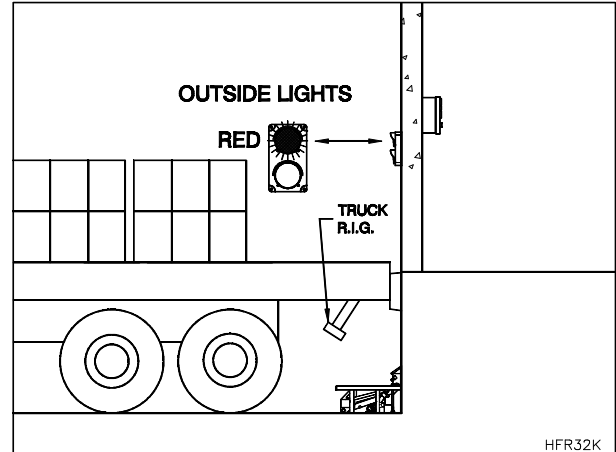

Figure 19: Secure Vehicle by Other Means

## LOADING / UNLOADING COMPLETE

If the trailer was secured by other means, remove them at this time. Immediately turn the selector switch to the “**ISENGAGE**” Position. The inside red and outside green light will be illuminated. The truck is free to depart and the dock is ready to receive another vehicle.

NOTE: If the vehicle R.I.G. has moved forward during loading / unloading (truck “creep” has occurred), there may be draw pull force and friction holding the restraint in the engaged position. If the restraint will not release, move the trailer back toward the dock to release the tension on the restraint, allowing it to lower.

# MAINTENANCE AND LUBRICATION



**ONLY TRAINED AND QUALIFIED PERSONNEL SHOULD PERFORM INSPECTION OR MAINTENANCE AND SERVICE PROCEDURES.**



**Before doing any installation, maintenance, inspection or trouble shooting, barricade all areas from traffic around the work area inside (and outside if applicable) for safety and post appropriate warning signs.**



**Arc flash and shock hazard PPE (personal protection equipment) required. De-energize equipment before working on or inside. Do not open cover without appropriate PPE. Refer to NFPA 70E for PPE requirements. This panel may contain more than one power source. Hazardous voltage will cause severe injury or death.**



**Before doing any electrical work, be certain that the power is disconnected with a fused disconnect, properly tagged and locked out. Fused disconnect and lockout device (supplied and installed by others) must meet with all applicable codes and regulations. All electrical work must be performed by a qualified electrician in accordance with all applicable codes and regulations.**

**NOTE:** A very high level of field issues with this type of equipment can be directly attributed to improper or incomplete installation. The installation instructions and information provided for this equipment is thorough. A step by step sequence for installation is provided. All steps must be followed and completed to provide a complete installation. Incomplete or improper installations can lead to equipment malfunction and / or damage, create safety issues and void warranties. Please follow all installation and set ups steps as indicated in the installation instructions and owner's manual. If you are unclear or uncertain regarding any of the steps contact your Pentalift representative for clarification. A copy of the completed steps listing with the sign off and photos of the installation as indicated at the conclusion of the installation instructions will be required prior to any Pentalift factory trouble shooting assistance.

**THE RELIEF VALVE ON THE POWER UNIT IS PRESET AT THE FACTORY. IT IS AN IMPORTANT SAFETY DEVICE. DO NOT ADJUST OR REMOVE THE RELIEF VALVE.**

**CLEANING:** The face of a loading dock is generally one of the dirtiest areas in a facility. Dirt and debris fall from the loading dock into and on the restraint area. The **HFR32 Vehicle Restraint** is designed to have a long trouble free operating life in this type of condition. However, the area around the restraint must be cleaned on a regular basis. Frequency will vary depending on the conditions at each individual location. Initially, cleaning must be done on a weekly basis. Thereafter, the frequency of cleaning can be adjusted to suit the specific individual installation conditions. Snow and ice must be cleaned away as soon as it accumulates.

## **CHECK ON A DAILY BASIS:**

Replace burnt out light bulbs on the control panel, or defective LED modules, immediately. Due to the continuous duty of dock traffic light systems and the life span of light bulbs, daily inspection of the light system should be performed. Spare light bulbs and an LED module should be kept on hand at all times for immediate replacement. Ensure that the proper lens color is in the proper position after checking bulbs and LED modules. Check the signal arm spring to ensure that it is not broken (See "REPLACEMENT PARTS" on page 33, item #19). Replace broken signal arm springs immediately. **USE ONLY GENUINE PENTALIFT REPLACEMENT PARTS**

Conduct the steps listed in the OPERATION AND PERFORMANCE CHECK Section of this manual. (See page 19) Check the raised height of the restraint and ensure that it is properly set. If adjustment is required follow the adjustment instructions. (See "ADJUSTMENT OF RESTRAINT ENGAGE HEIGHT" on page 32)

**NOTE: Read the SAFETY INFORMATION AND WARNINGS before servicing the HFR32 Vehicle Restraint. (See page ii.)**

**NOTE: It is the owner's responsibility to ensure that all labeling remains legible and in its original position throughout the life of the product (See Safety Labeling Section, Page 2).**

**NOTE: Inspect equipment for protective coatings (i.e. paint) that have deteriorated or been removed. Prepare affected area and reapply protective coating as required using Tremclad High Performance Rust Enamel (Gloss Dark Machine Grey) if zing coating not used.**

**NOTE: At every maintenance interval, inspect the HFR32 Vehicle Restraint for any damaged or worn parts. If any damaged or worn parts are found, discontinue use of the vehicle restraint and/or repair immediately.**

At every maintenance/lubrication interval, check that the signal bar spring is in place and that the spring retaining bolt is tight against signal bar spring, ensure bolt is secured with jam nut.

The recommended lubrication service interval is every 30 days or at a greater frequency as required in severe environments. For maximum bearing life, the recommended lubricant is NLGI Grade 2 grease with EP and MOS2 additives.

Also note that the power unit fluid should be changed every 12 months. The required hydraulic oil is Dexron III Automatic Transmission Fluid.

### **NOTICE: HYDRAULIC FLUID**

The standard hydraulic oil supplied with the equipment is HVI-22 Hydraulic fluid. This fluid is suitable for use from approximately -30° C (-22F) minimum to +35°C (+95°F) unless otherwise specified on the specific equipment order. The equipment can be operated in temperatures slightly higher and lower than the temperatures stated on an intermittent basis. Operating the equipment for extended periods of times at temperatures higher or lower than the stated temperatures above may result in functional issues for the equipment. It may also result in damage and issues to hydraulic components. As the actual temperature the equipment is used in moves further away from the recommended temperature range the concern points increase. Abuse and overuse in this regard will void all warranty.

The standard replacement Hydraulic Fluid is HVI-22 hydraulic fluid which accommodates the temperature range stated above. There are special hydraulic fluids available to accommodate temperatures that are consistently and or significantly lower or higher than those stated above. In many cases the use of these types of specialty fluids will result in the requirement for hydraulic fluid changes during seasonal yearly temperature changes.

Recommended for colder temperatures is Hydraulic Fluid 5606A  
Recommended for warmer temperatures is Hydraulic Fluid HVI-32

If the hydraulic oil provided from the factory is non-standard, refer to the hydraulic reservoir fluid label which will specify the particular oil requirements.

Note: When approaching or operating in temperature beyond the high and low temperature ranges of the ratings for the hydraulic fluids, there may be some adverse effects to the functionality of the equipment. This could include (but not be limited to) harmonics and vibration of cylinders, inhibited or reduced equipment performance and function, slower cycle times, hydraulic leaks unwanted activation of velocity fuses. To address concerns of this nature a change in hydraulic fluid or a special oil additive maybe required. Contact your Pentlift representative for more information.

**Note:** The remote installation location of the hydraulic power unit can also help address concerns with hydraulic fluid temperature ranges. For example if the equipment is purchased with a remote power unit, the power unit can be installed in a warmer (indoor) location. In this arrangement, even though the main equipment and it's hydraulic components maybe exposed to more extreme temperatures, the hydraulic power unit and the hydraulic fluid stored in it will be exposed to and therefore absorb the more moderate and desirable internal temperature. During operation the oil in the power unit will quickly mix with the oil in the equipment and will typically mix to a more desirable temperature level.

**Note:** That if the hydraulic power unit is installed in a pit, as is usually the case for dock levelers, the pit will have moderating effect on the temperature the hydraulic power unit is exposed to. This should be part of the consideration of hydraulic fluid selection.

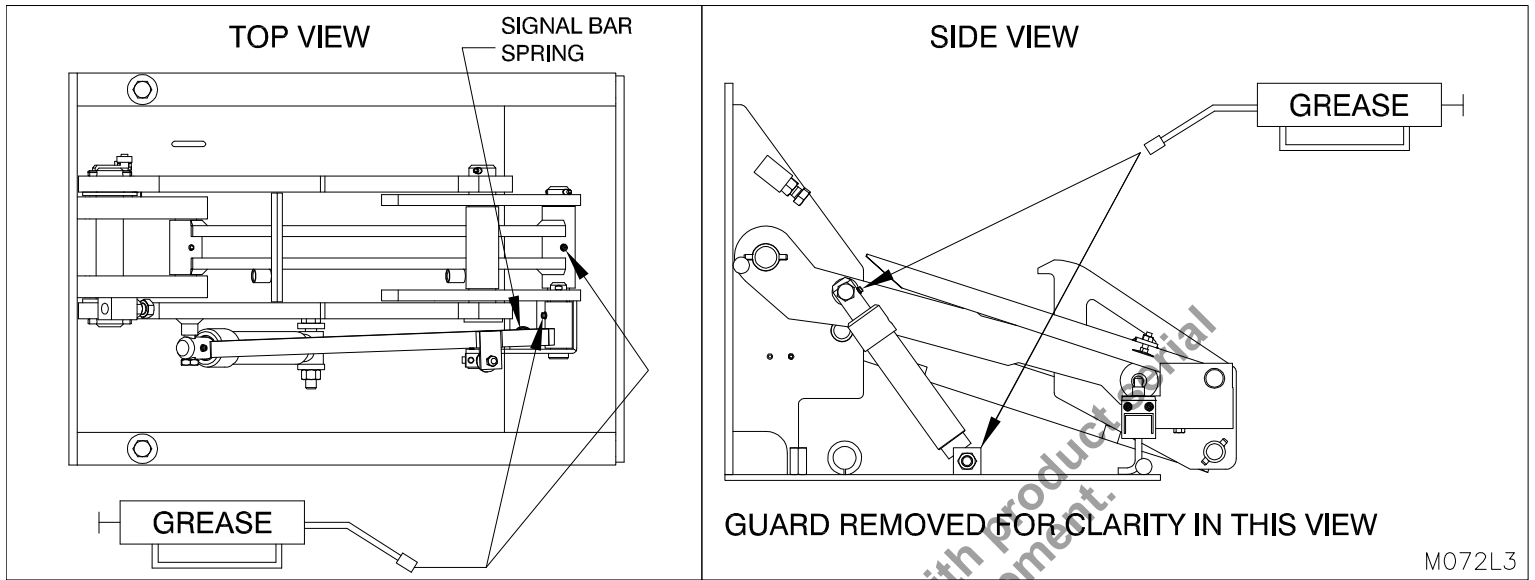

Figure 20: Lubrication Points

# TROUBLE SHOOTING GUIDE

**NOTE:** This equipment has been fully tested and confirmed to be operational at the factory. Historically, the majority of operating problems are caused by unnecessary tampering by unqualified personnel. To conform to the terms of the Warranty, contact your authorized Pentalift representative if you are having any difficulty with the restraint during the warranty period. Do not risk voiding the warranty by tampering with the equipment.



**ONLY TRAINED AND QUALIFIED PERSONNEL SHOULD PERFORM INSPECTION OR MAINTENANCE AND SERVICE PROCEDURES.**



**THE RELIEF VALVE ON THE POWER UNIT IS PRESET AT THE FACTORY. IT IS AN IMPORTANT SAFETY DEVICE. DO NOT ADJUST OR REMOVE THE RELIEF VALVE.**



**Before doing any installation, maintenance, inspection or trouble shooting, barricade all areas from traffic around the work area inside (and outside if applicable) for safety and post appropriate warning signs.**



**Before doing any electrical work, be certain that the power is disconnected with a fused disconnect, properly tagged and locked out. Fused disconnect and lockout device (supplied and installed by others) must meet with all applicable codes and regulations. All electrical work must be performed by a qualified electrician in accordance with all applicable codes and regulations.**



**Arc flash and shock hazard PPE (personal protection equipment) required. De-energize equipment before working on or inside. Do not open cover without appropriate PPE. Refer to NFPA 70E for PPE requirements. This panel may contain more than one power source. Hazardous voltage will cause severe injury or death.**

## **NOTICE**

See page 24 for recommended hydraulic oil.

**NOTE:** A very high level of field issues with this type of equipment can be directly attributed to improper or incomplete installation. The installation instructions and information provided for this equipment is thorough. A step by step sequence for installation is provided. All steps must be followed and completed to provide a complete installation. Incomplete or improper installations can lead to equipment malfunction and / or damage, create safety issues and void warranties. Please follow all installation and set ups steps as indicated in the installation instructions and owner's manual. If you are unclear or uncertain regarding any of the steps contact your Pentalift representative for clarification. A copy of the completed steps listing with the sign off and photos of the installation as indicated at the conclusion of the installation instructions will be required prior to any Pentalift factory trouble shooting assistance.

### **1. Restraint will not rise when the selector switch is turned to the "II" (ENGAGED) position:**

- a. Confirm that the signal bar limit switch has not been depressed (See "Figure 23: Setting the Signal Bar Limit Switch" on page 31).
- b. Check the signal bar spring is in place (See "Figure 23: Setting the Signal Bar Limit Switch" on page 31).
- c. Check signal bar limit switch adjustment on signal bar (See "Figure 23: Setting the Signal Bar Limit Switch" on page 31).
- d. Check that hydraulic fluid level is approximately two inches from the top of the reservoir when the restraint is completely lowered.
- e. Examine all moving parts for obstructions or binding.
- f. Check all wiring and hydraulic connections.
- g. Confirm that power is reaching the power unit.
- h. Check if the inputs I-1 on the PLC screen is highlighted. If not, connections going in the terminal needs to be checked. (See Figure 21A and 21B on page 29).
- i. Check if the output Q2 gets highlighted (See Figure 21A and 21B on page 29).
- j. If the problem cannot be solved, consult your authorized Pentalift representative.

**2. Restraint rises but has a jerking movement:**

- a. Check that hydraulic fluid level is approximately two inches from the top of the reservoir when the restraint is completely lowered.
- b. Check of any obstructions and bindings restricting free motion.
- c. Check signal bar limit switch adjustment (See "Figure 23: Setting the Signal Bar Limit Switch" on page 31).
- d. If the problem cannot be solved, contact your authorized Pentalift Representative.

**3. Pump continues to run when restraint is at the raised position:**

- a. check if the signal bar limit switch is getting depressed once the restraint is at the raised position.
- b. check if the limit switches are wired at the correct terminal blocks inside the panel by referring to the electrical schematic.
- c. confirm all the wiring is correct and there are no loose connections inside the panel.
- d. check if the input I3 on the PLC screen highlights once the signal bar limit switch is depressed.
- e. If the problem cannot be solved, contact your authorized Pentalift Representative.

**4. The restraint will not raise completely:**

- a. Check that hydraulic fluid level is approximately two inches from the top of the reservoir when the restraint is completely lowered.
- b. Check for any obstructions or binding to ensure the hook can move freely.
- c. If the problem cannot be solved, contact your authorized Pentalift Representative.

**5. The Restraint will not lower:**

- a. Check for any obstructions and binding to ensure the hook can move freely.
- b. The down travel limit switch lower position setting may need to be reset. See "SETTING THE DOWN TRAVEL LIMIT SWITCH LOWERED POSITION:" on page 30.
- c. Check for power to the lowering valve.
- d. Check if the input I4 is highlighted on the PLC screen (See "Figure 21B: I/O on PLC screen" on page 29).  
NOTE: If the vehicle R.I.G. has moved forward during loading / unloading (truck "creep" has occurred), there may be draw pull force and friction holding the restraint in the engaged position. If the restraint will not release, move the trailer back toward the dock to release the tension on the restraint, allowing it to lower.
- e. Ensure lowering extension spring is in place (See item 18, "Figure 25: Replacement Parts" on page 34).
- f. If the problem cannot be solved, contact your authorized Pentalift Representative.

**6. Alarm Sounds and Restraint is not completely raised:**

- a. Check the signal bar wiring and limit switch adjustments.
- b. Check for leaking hose or hydraulic connections.
- c. Check that hydraulic fluid level is approximately two inches from the top of the reservoir when the restraint is completely lowered.
- d. Confirm that the signal bar limit switch is not activated. (See "Figure 23: Setting the Signal Bar Limit Switch" on page 31)
- e. If the problem cannot be solved, contact your authorized Pentalift Representative.

**7. Outside red light remains illuminated and will not change to green.**

- a. Confirm that restraint is able to completely lower. The rear limit switch will not switch the outside lights unless the restraint hook is completely lowered and in contact with the bottom plate.
- b. Check down travel limit switch lower position setting. (See "SETTING THE DOWN TRAVEL LIMIT SWITCH LOWERED POSITION:" on page 30)
- c. Confirm that the signal bar limit switch is not activated. (See "Figure 23: Setting the Signal Bar Limit Switch" on page 31)
- d. Confirm that the input I3 on PLC screen is not highlighted (See Figure 21B : I/O on PLC Screen" on page 29).
- e. If the problem cannot be solved, contact your authorized Pentalift Representative.

If damaged or worn parts are detected upon inspection, replacement must be undertaken immediately. **The vehicle restraint must not be used until replacement is completed.** Parts are readily available from your Pentalift representative.

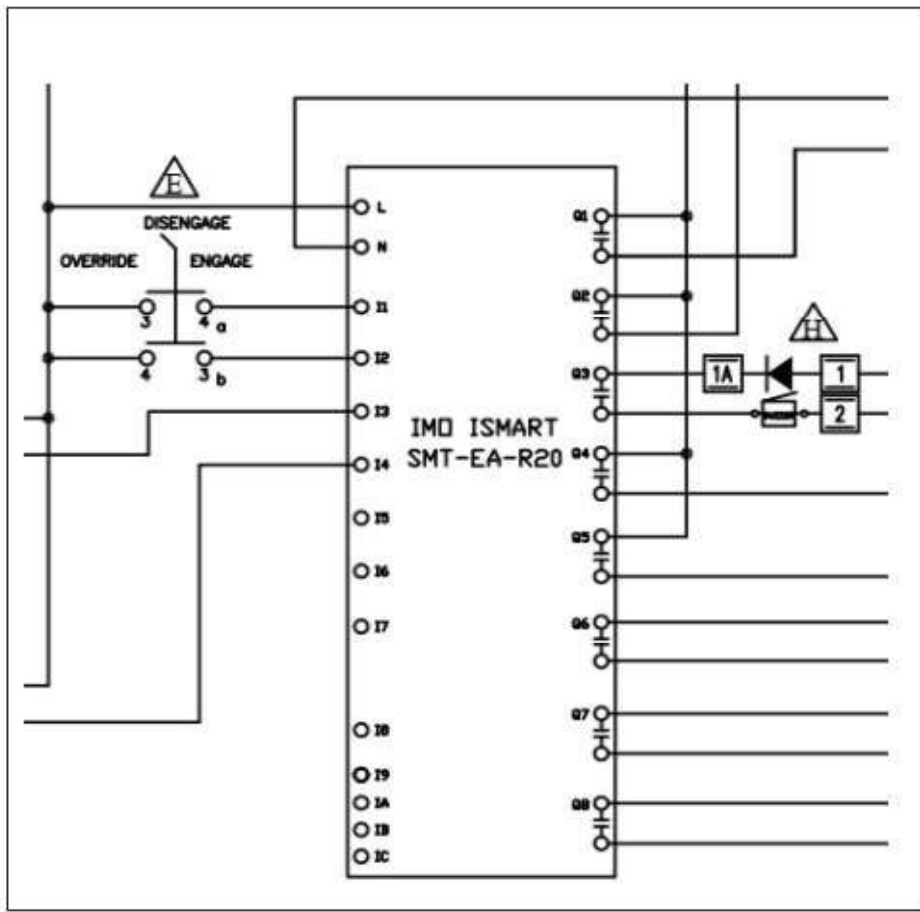
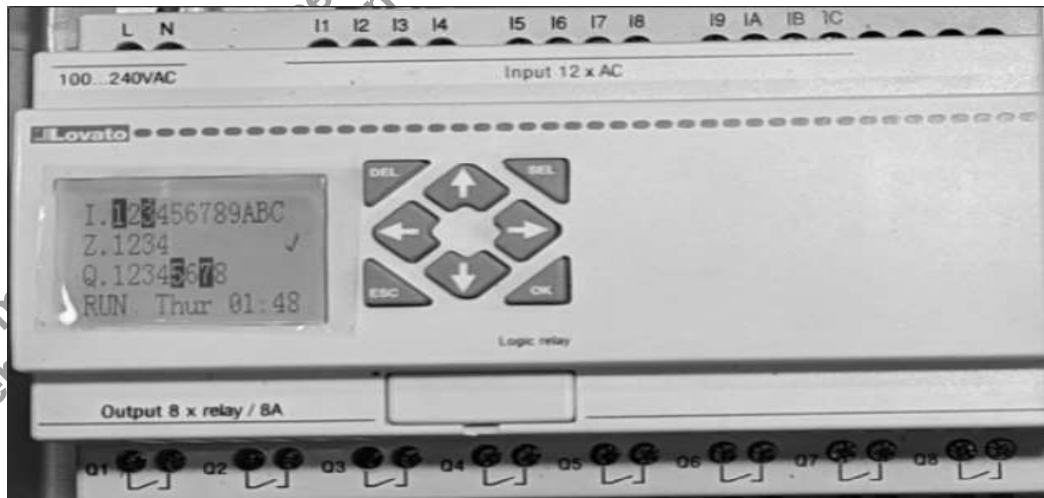

Figure 21A: PLC I/O Connections



IN THIS FIGURE,

1. INPUTS I-1 AND I-3 ARE SWITCHED ON.
2. OUTPUTS Q-5 AND Q-7 ARE SWITCHED ON.

Figure 21B: Inputs/Outputs on PLC Screen

# RESTRAINT ADJUSTMENTS

## SETTING THE DOWN TRAVEL LIMIT SWITCH LOWERED POSITION:



TO ENSURE THAT THE RESTRAINT IS NOT INADVERTANTLY ACTIVATED WHILE THE FOLLOWING ADJUSTMENTS ARE BEING MADE, BARRICADE ALL AREAS FROM TRAFFIC AROUND THE WORK AREA INSIDE (AND OUTSIDE IF APPLICABLE) FOR SAFETY (PARTICULARLY THE CONTROL BOX LOCATION) AND POST APPROPRIATE WARNING SIGNS.

- a) Remove the guard assembly (See "Figure 4: Remove/Replace the Guard Assembly" on page 5).
- b) Raise the restraint and place a 1/2" shim under the hooking arm (See "Figure 22: Setting the Down Travel Limit Switch" on page 30).
- c) Lower the restraint onto the 1/2" shim.
- d) Loosen the set screw on the limit switch roller arm.
- e) Turn the roller arm on the post until the roller contacts the hook arm.
- f) Tighten the set screw of the roller arm.
- g) Raise the restraint; remove the 1/2" shim  
Lower the restraint with no shim and confirm the outside green light is illuminated.
- h) Raise the restraint and place a 3/4" shim under the hooking arm.
- i) Lower the restraint onto the 3/4" shim and confirm that the outside red light is illuminated.

**NOTE:** When the restraint is in the lowered position with **no shim** under the hooking arm, the **outside green light** should be illuminated.

When the restraint is in the lowered position with the **3/4" shim** under the hooking arm, the **outside red light** should be illuminated.

Repeat items b) to f) until this is accomplished.

- k) Remove all shims.
- l) Reinstall the guard assembly.

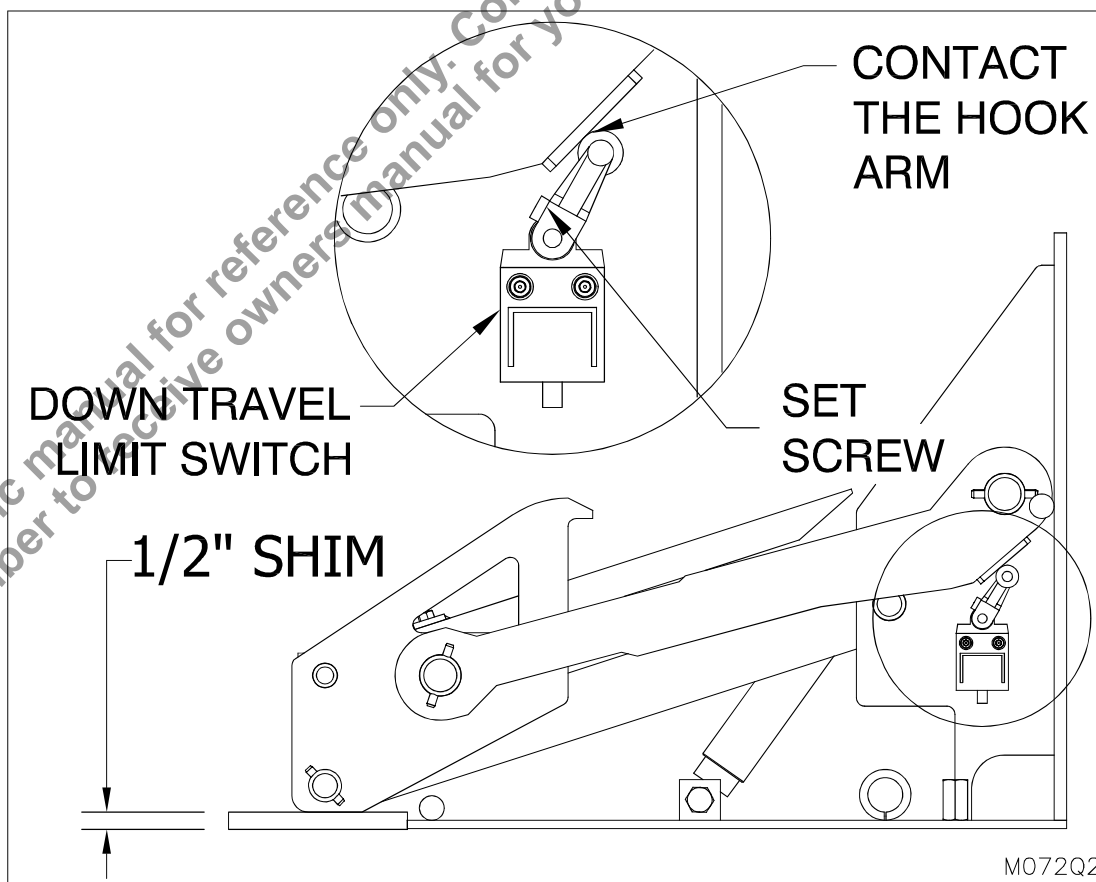

Figure 22: Setting the Down Travel Limit Switch

## RESTRAINT ADJUSTMENTS (CON'T)



TO ENSURE THAT THE RESTRAINT IS NOT INADVERTANTLY ACTIVATED WHILE THE FOLLOWING ADJUSTMENTS ARE BEING MADE, BARRICADE ALL AREAS FROM TRAFFIC AROUND THE WORK AREA INSIDE (AND OUTSIDE IF APPLICABLE) FOR SAFETY (PARTICULARLY THE CONTROL BOX LOCATION) AND POST APPROPRIATE WARNING SIGNS.

### SIGNAL BAR SWITCH ADJUSTMENTS

- Raise the restraint.
- Raise the signal bar and confirm that the signal bar spring is in position (See "Figure 23: Setting the Signal Bar Limit Switch" on page 31).
- Depress the signal bar, compressing the signal bar spring to the fully lowered position. The signal bar should be stopped by the mechanical stop.
- Loosen the jam nut and turn the adjusting screw until the roller assembly of the limit switch is 1/8" from being fully depressed.

**Note: It is important that this setting be correct. If the contact point of the adjustment screw is too high, the signal bar may open and close the switch during bouncing of the truck / trailer. This will cause the buzzer to turn on and off. If the adjustment screw is too low, the limit switch will be damaged.**

- Tighten the jam nut while ensuring the adjustment screw does not move.

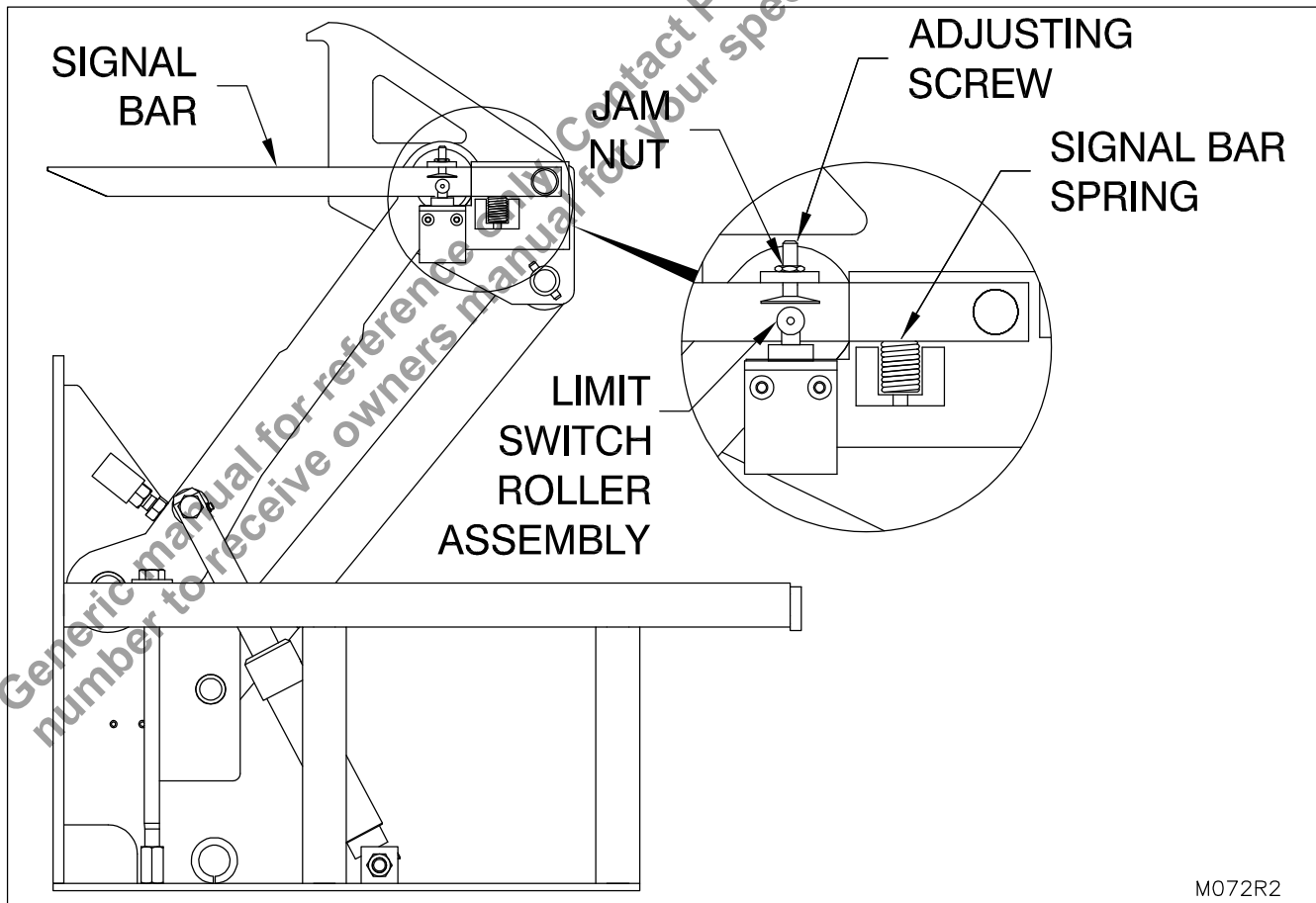

Figure 23: Setting the Signal Bar Limit Switch

## ADJUSTMENT OF RESTRAINT ENGAGE HEIGHT

**NOTE: THE RAISED HEIGHT IS PRESET AT THE FACTORY AND SHOULD NOT REQUIRE ADJUSTMENT**

**NOTE: THE NORMAL RAISED HEIGHT OF THE RESTRAINT IS 29". IF THE RAISED HEIGHT IS ABOVE 29" DAMAGE TO THE SIGNAL ARM MAY RESULT.**

If adjustment is required, proceed with the following steps.

**IF RAISED HEIGHT IS TOO LOW:** Loosen stop block locking nut. Turn adjustment bolt **in** to **increase** raised height. When proper height is achieved, tighten lock nut against the adjustable stop block. (See "Figure 24: Raised Height Adjustment" on page 32)

**IF RAISED HEIGHT IS TOO HIGH:** Loosen stop block locking nut. Turn adjustment bolt **out** to **decrease** raised height. When proper height is achieved, tighten lock nut against the adjustable stop block. (See "Figure 24: Raised Height Adjustment" on page 32)

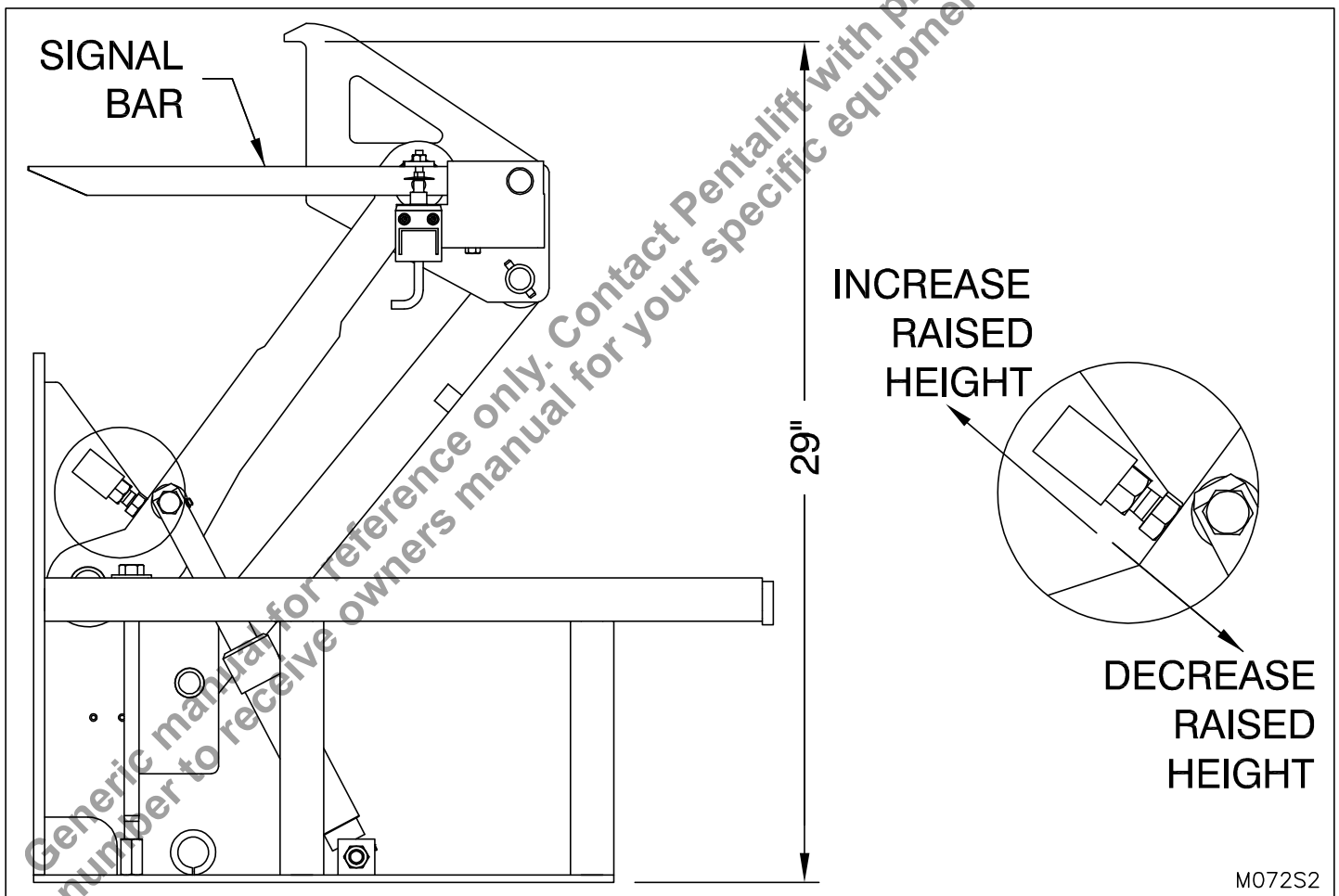

Figure 24: Raised Height Adjustment

# REPLACEMENT PARTS

## USE ONLY GENUINE PENTALIFT REPLACEMENT PARTS



To ensure proper functioning, durability and safety of the product, only genuine pentlift replacement parts must be used. Altering the product from its original manufactured configuration must not be done. Pentlift equipment Corporation disclaims all liability for failure to comply with this warning. Warranties are specifically disclaimed in the event the purchaser fails to comply with this warning.

To expedite order processing when ordering parts, provide the following information to your Pentlift representative:

1. Model and Serial Number of equipment.
2. Part Number, Description and Quantity.
3. Shipping Instructions.

Fuse I.D.	Single Phase Standalone	
	Part No.	Description
F1	060-0537	2 Amp / 250V Fuse
F2	060-0496	7 Amp / 250V Fuse

Fuse I.D.	Single Phase Combo	
	Part No.	Description
F1	060-0537	2 Amp / 250V Fuse

Fuse I.D.	Three Phase Combo		
	Voltage	Part No.	Description
F1 and F2	575V	060-0024	1/2 Amp / 600V
	460V	060-0024	1/2 Amp / 600V
	230V	060-0300	1 Amp / 600V
F3	575V	060-0537	2 Amp / 250V
	460V	060-0537	2 Amp / 250V
	230V	060-0537	2 Amp / 250V

Three Phase Control Box Replacement Parts (See page 38)		
Power Unit Voltage	Part Numbers	
	Item 26 Transformer	Item 16 Overload
575 / 120V	060-0937	060-1042
460 / 120V	060-0937	
230 / 120V	060-0943	060-1041

**NOTE:** State Model # and Serial # when ordering replacement parts.

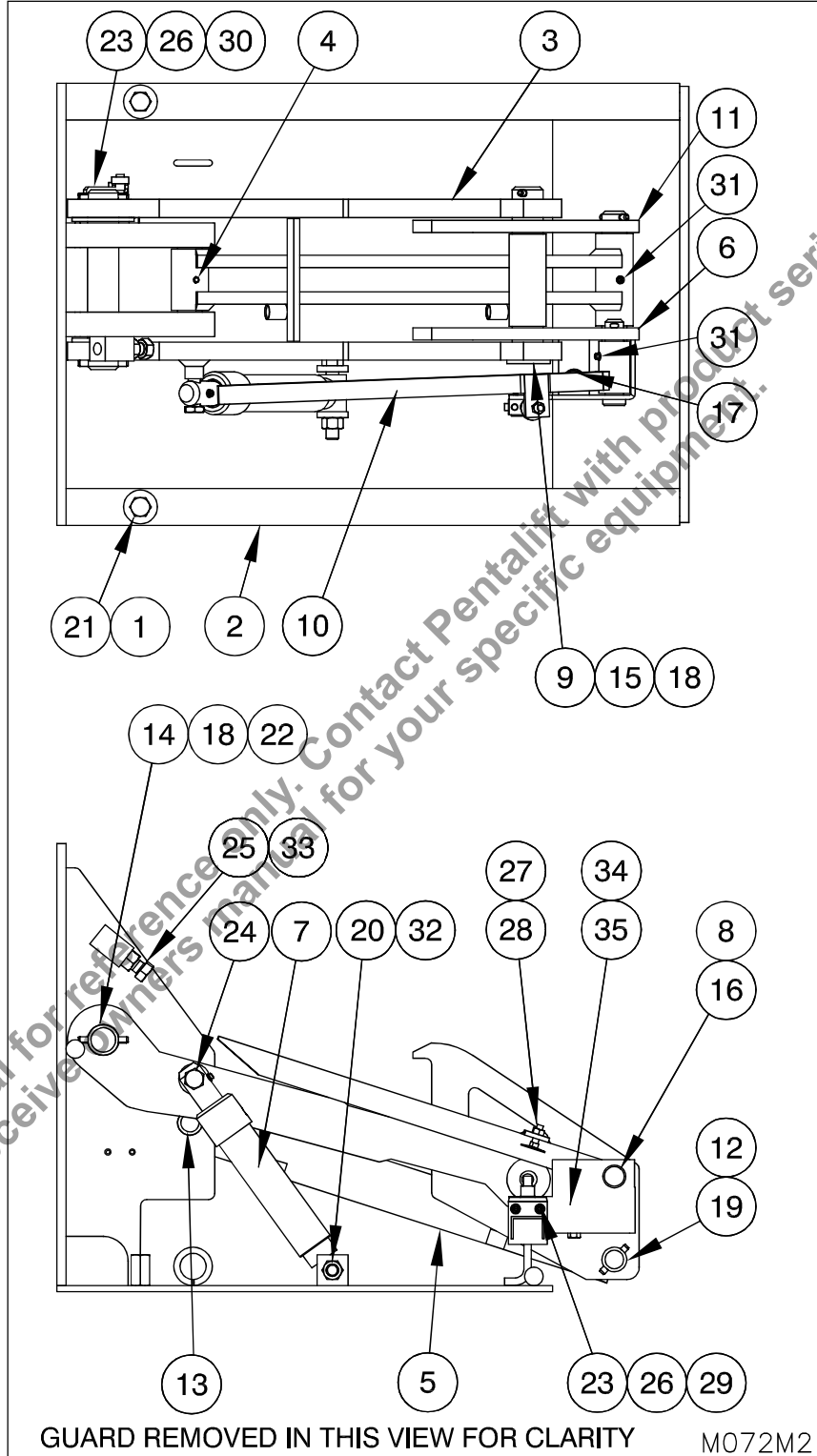

**Figure 25: Replacement Parts**

# RESTRAINT REPLACEMENT PARTS LIST

USE ONLY GENUINE PENTALIFT REPLACEMENT PARTS

<u>Item #</u>	<u>Part No.</u>	<u>Description</u>
1	0720317	Bolt
2	8120014	Guard Weldment
3	8120072	Upper Arm Weldment
4	0800042	Spring Pin
5	8120095	Lower Arm Weldment
6	8120056	Signal Arm Hook Weldment
7	8200018	Cylinder Assembly
8	0820010	Cotter Pin
9	8120055	Upper Pin Weldment
10	8120058	Signal Arm Weldment
11	3120077	Drilled Hook
12	3120112	Lower Arm Pin
13	3120114	Flush Lower Pin
14	3120113	Upper Arm Pin
15	3120017	Hook Spacer
16	3020392	Clevis Pin
17	0970042	Signal Arm Spring (Green)
18	0800004	Spring Pin
19	0800001	Spring Pin
20	0700017	Nylock Nut
21	0740117	Flat Washer
22	0740103	Flat Washer
23	0740068	Lock Washer
24	0720400	Shoulder Bolt
25	0720001	Hex Bolt
26	0720118	Machine Screw
27	0720177	Elevator Screw
28	0700007	Hex Nut
29	0601224	Limit Switch
30	0601225	Limit Switch
31	0520170	Grease Fitting
32	0720290	Hex Bolt
33	0700006	Hex Nut
34	0720372	Spring Retaining Bolt
35	0700018	Nylock Nut

**NOTE:** State Model # and Serial # when ordering replacement parts.

# CONTROL PANEL REPLACEMENT PARTS

SINGLE PHASE STANDALONE REF: 161-0497

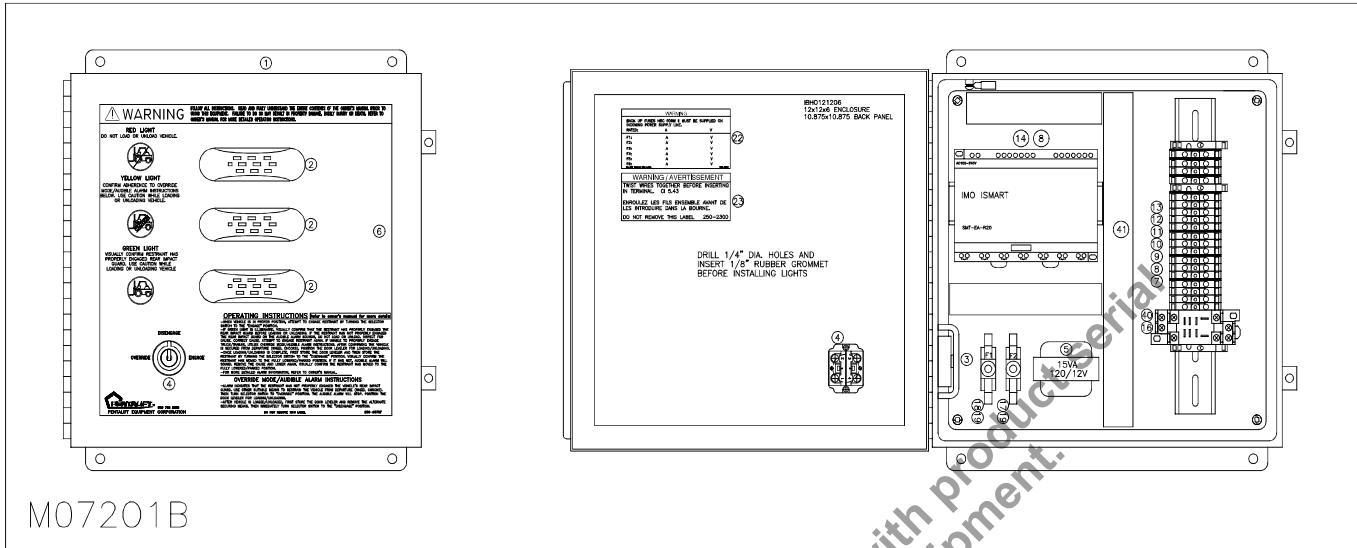
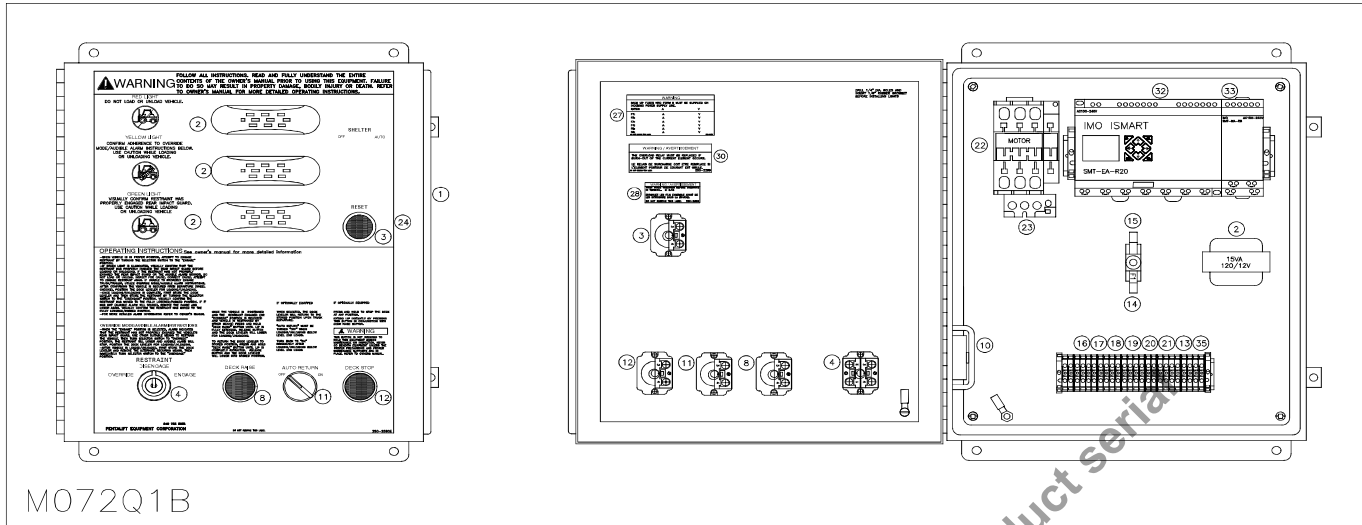

Figure 26: Single Phase standalone Control Panel

<u>Item</u>	<u>Part No.</u>	<u>Description</u>
1	060-0233	Electrical Enclosure
2	161RGA	Red Green Amber Light Assembly
3	161BUZ	120Vac Buzzer Assembly
4	161VRSW2	Restraint Switch Assembly
5	060-0209	15VA 20/12V Transformer
6	250-2575	Control Panel Label
7	060-0549	Jumper Bar 32A 10 Pole
8	060-0293	Din Rail Mounting Bar
9	060-1056	Self Grounding Terminal Block
10	060-0548	Terminal Block Beige
11	060-0463	Terminal Ends
12	060-0466	Terminal Markers
13	060-0464	Terminal Stops
14	060-0933	IMO Logic Relay
16	060-0552	120Vac DPDT Realy
17	060-0496	Fuse, 7A/250V - Time Delay
18	060-0537	Fuse, 2A/250V - Time Delay
19	060-0380	1/4" Fuse Holder
22	250-2297	CSA Label - Fuses
23	250-2300	CSA Label - Twist Wires

**NOTE:** State Model # and Serial # when ordering replacement parts.



M072Q1B

Figure 28: Single Phase Combo Control Panel

Item	Part No.	Description
1	060-0592	Electrical Enclosure
2	161RGA	Red Amber Green Panel Light Assembly
3	161RB	Electric Reset Button Assembly
4	161VRSW2	Restraint Switch Assembly
5	060-0209	15VA 20/12V Transformer
8	161DR	Deck Raise Button
10	161BUZ	120V Buzzer Assembly
11	161AR	Auto Return Switch Assembly
12	161DS	Deck Stop Switch Assembly
13	060-0293	Din Rail Mounting Bar
14	060-0537	Fuse - 2A/250V Time Delay
15	060-0380	Fuse Holder
16	060-0548	Terminal Block, Beige
17	060-1056	Terminal Block, Self Grounding
18	060-0463	Terminal Block End
19	060-0466	Terminal Markers
20	060-0464	Terminal Block End Stop
21	060-0549	Terminal Block Jumper Bar, 10 Pole
22	060-1036	Contactor
23	NOTE	Thermal Overload
24	250-2580	Control Panel Label
27	250-2297	CSA Label - Fuses
28	250-2300	CSA Label - Twist Wires
30	250-2299	CSA Label - Replace Overload
32	060-0933	IMO Logic Relay
33	060-0934	IMO Logic Relay - Expansion Module
35	060-1083	22 KΩ Resistor

**NOTE:** State Model # and Serial # when ordering replacement parts.

**THREE PHASE COMBO PANEL REF: 161-0473**

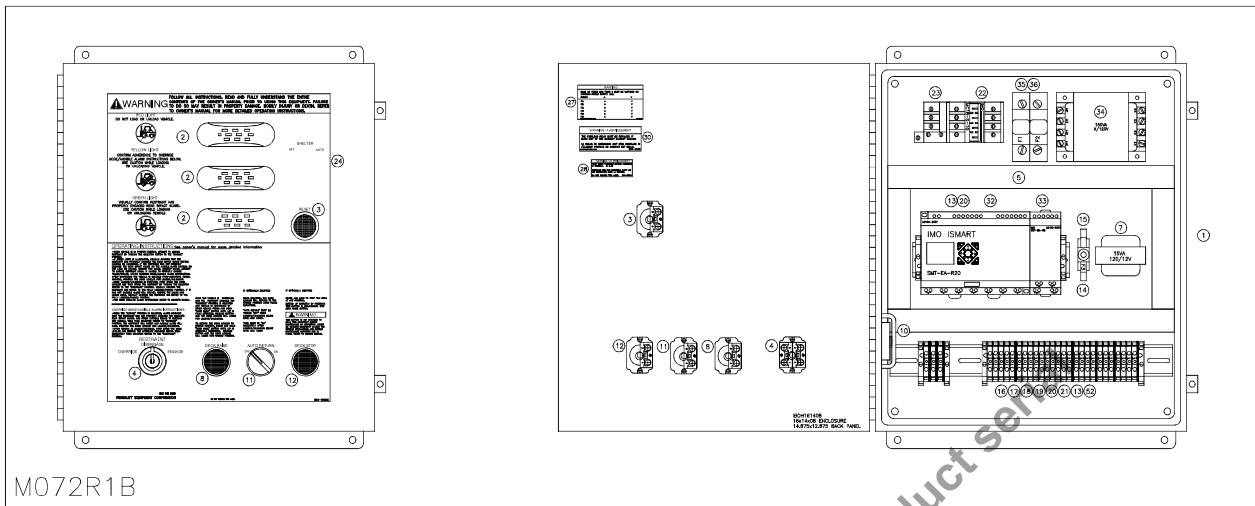

**Figure 29: Three Phase Combo Panel**

<u>Item</u>	<u>Part No.</u>	<u>Description</u>
1	060-0248	Electrical Enclosure
2	161RGA	Red Amber Green Panel Light Assembly
3	161RB	Electric Reset Button Assembly
4	161VRSW2	Restraint Switch Assembly
7	060-0209	15VA 20/12V Transformer
8	161DR	Deck Raise Button
10	161BUZ	120V Buzzer Assembly
11	161AR	Auto Return Switch Assembly
12	161DS	Deck Stop Switch Assembly
13	060-0293	Din Rail Mounting Bar
14	060-0537	Fuse - 2A/250V Time Delay
15	060-0380	Fuse Holder
16	060-0548	Terminal Block, Beige
17	060-1056	Terminal Block, Self Grounding
18	060-0463	Terminal Block End
19	060-0466	Terminal Markers
20	060-0464	Terminal Block End Stop
21	060-0549	Terminal Block Jumper Bar, 10 Pole
22	060-1036	Contactor
23	NOTE	Thermal Overload
24	250-2580	Control Panel Label
27	250-2297	CSA Label - Fuses
28	250-2300	CSA Label - Twist Wires
30	250-2299	CSA Label - Replace Overload
32	060-0933	IMO Logic Relay
33	060-0934	IMO Logic Relay - Expansion Module
34	NOTE	150VA Transformer
35	060-0381	Class CC Fuse Holder
36	NOTE	Primary Fuses
52	060-1083	22 KΩ Resistor

**NOTE:** State Model # and Serial # when ordering replacement parts.

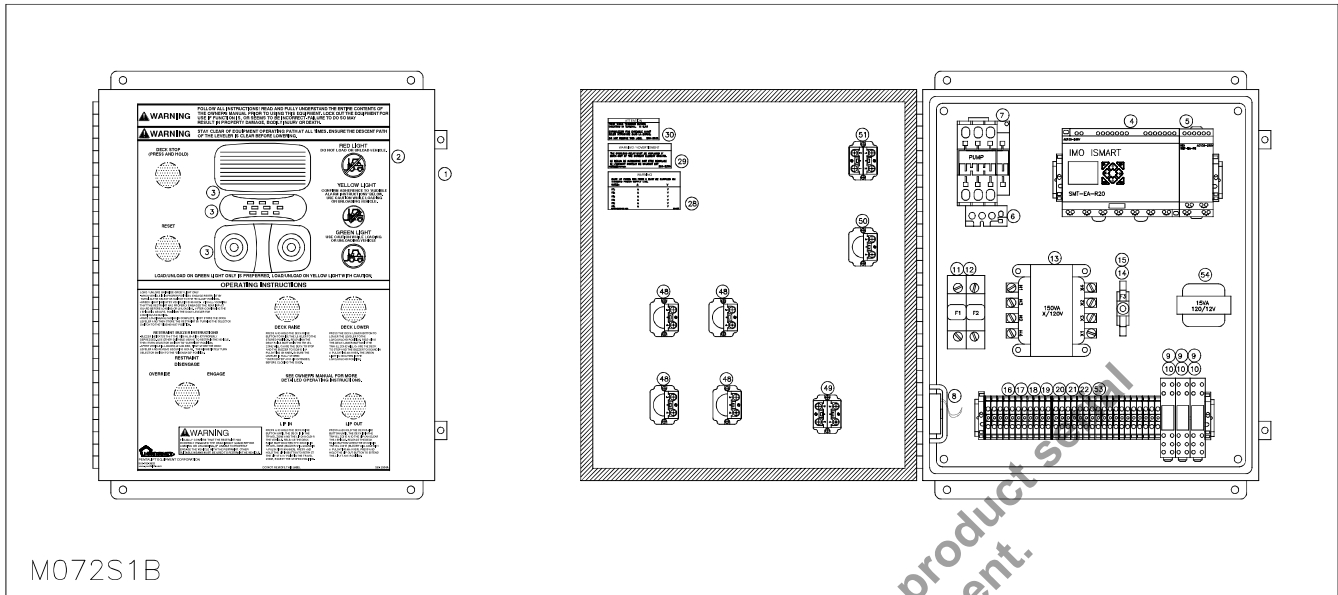

Figure 30: Vertical Dock Leveler Control Panel

Item	Part No.	Description
1	060-0248	Electrical Enclosure
2	250-2504	Instruction Label
3	161RGA	Red Amber Green Panel Light Assembly
4	060-0933	IMO Logic Relay
5	060-0934	IMO Logic Relay - Expansion Module
6	NOTE	Thermal Overload
7	060-1036	Contactor
8	161BUZ	120V Buzzer Assembly
9	060-0554	8 Pin Relay Mount
10	060-0551	DPDT 120V Relay
11	NOTE	Fuse - Class CC Time Delay
12	060-0381	Double Body Class CC Fuse Holder
13	Note	150VA Transformer
14	060-0537	Fuse - 2A/250 Time Delay
15	060-0380	Fuse Holder
16	060-0548	Terminal Block, Beige
17	060-1056	Terminal Block, Self Grounding
18	060-0463	Terminal Block End
19	060-0466	Terminal Markers
20	060-0464	Terminal Block End Stop
21	060-0549	Terminal Block Jumper Bar, 10 Pole
22	060-0293	Din Rail Mounting Bar
28	250-2297	CSA Label - Fuses
29	250-2299	CSA Label - Replace Overload
30	250-2300	CSA Label - Twist Wires
48	161DR	Deck Raise Button
49	161VRSW2	Restraint Switch Assembly
50	161RB	Electric Reset Button Assembly
51	161STOP	Emergency Stop Button Assembly
53	060-1083	22 K $\Omega$ Resistor
54	060-0209	15VA 20/12V Transformer

**NOTE:** State Model # and Serial # when ordering replacement parts.

# DELUXE OUTSIDE LIGHT REPLACEMENT PARTS

USE ONLY GENUINE PENTALIFT REPLACEMENT PARTS

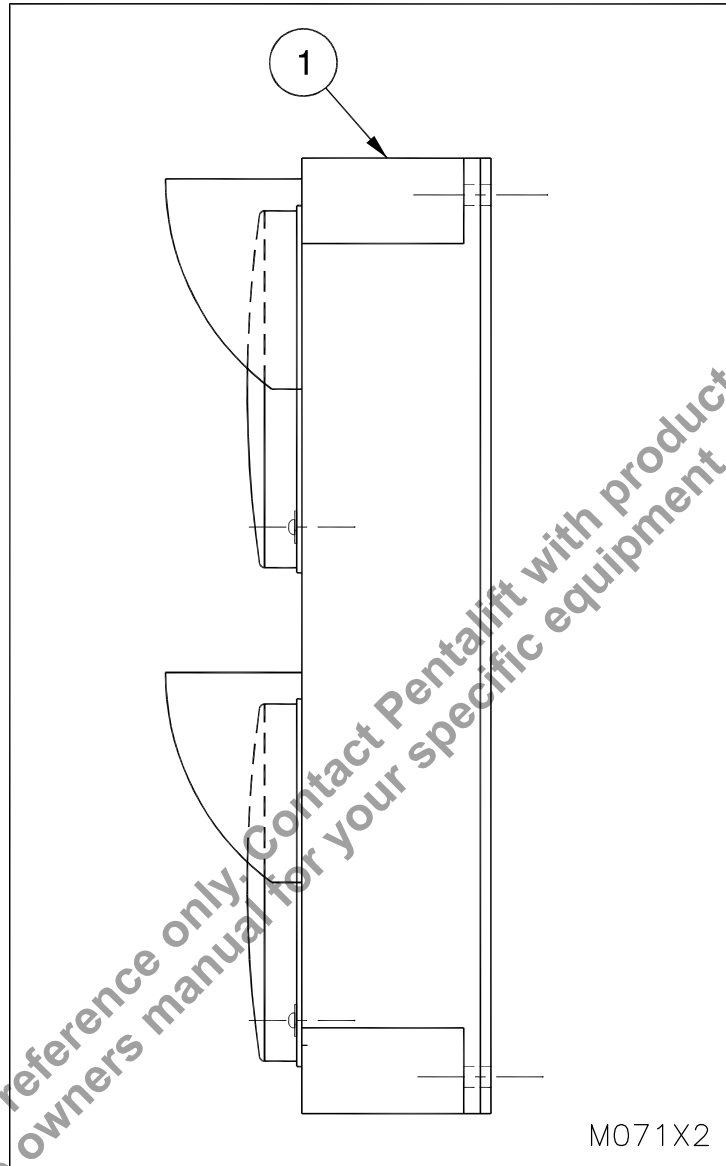
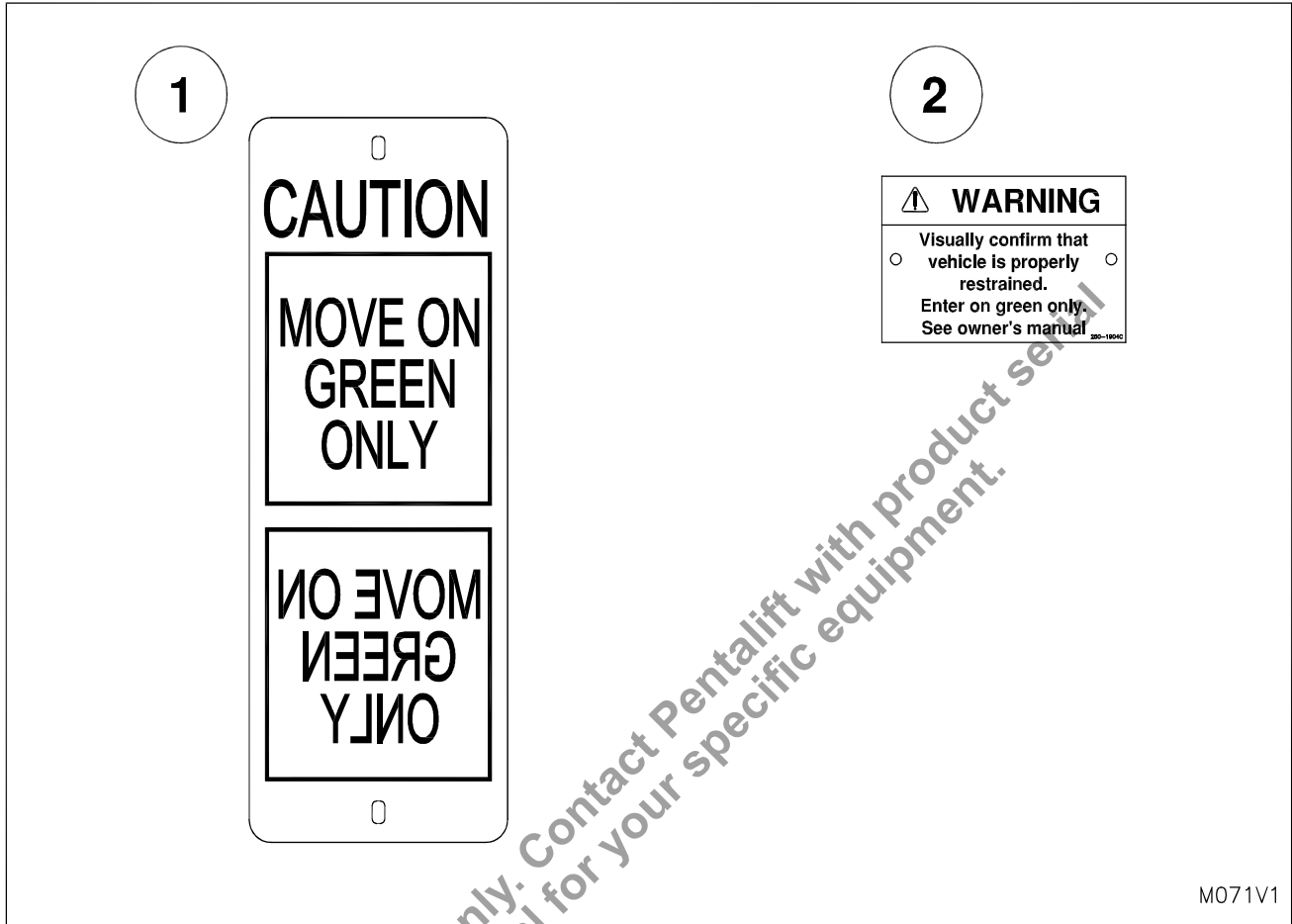

Figure 31: Outside Light Replacement Parts

<u>Item</u>	<u>Part No.</u>	<u>Description</u>
1	060-1271	12V Traffic Light Fixture

**NOTE:** State Model # and Serial # when ordering replacement parts.

# REPLACEMENT SIGNS



M071V1

Figure 32: Replacement Signs

<u>Item</u>	<u>Part No.</u>	<u>Description</u>
1	250-6991	Caution Sign-Move on Green Only
2	250-1904	Interior Shipper / Receiver Sign

# LIST OF ILLUSTRATIONS

Figure 1: Safety Labeling . . . . .	2
Figure 2: Draw Pull Forces . . . . .	4
Figure 3: Shim Locations . . . . .	5
Figure 4: Remove/Replace the Guard Assembly . . . . .	5
Figure 5: Weld Locations . . . . .	6
Figure 6B: Dock Leveler/Restraint Combo Unit . . . . .	8
Figure 6C: Vertical Dock Leveler/Restraint Combo Unit . . . . .	9
Figure 6D: 100K Dock Leveler/Restraint Combo Unit . . . . .	10
Figure 6: Power Unit and Control Panel . . . . .	6
Figure 7: Wall Mounted Power Unit . . . . .	6
Figure 8: Conduit / Outside Light / Outside Sign Locations . . . . .	11
Figure 9: Extension Shim Locations . . . . .	12
Figure 10: Optional Extension . . . . .	13
Figure 11: Horizontal Surface Mounting Installation . . . . .	16
Figure 12: Inside Red Light . . . . .	21
Figure 13: Restraint Lowered . . . . .	21
Figure 14: Inside Green Light . . . . .	21
Figure 15: Vehicle in Position . . . . .	21
Figure 16: R.I.G. Not Secure . . . . .	23
Figure 17: Inside Light Red and Alarm Sounding . . . . .	23
Figure 18: Inside Light Yellow . . . . .	23
Figure 19: Secure Vehicle by Other Means . . . . .	23
Figure 20: Lubrication Points . . . . .	26
Figure 21A: PLC input/output identification . . . . .	27
Figure 21B: Input/output on PLC screen . . . . .	27
Figure 22: Setting the Down Travel Limit Switch . . . . .	30
Figure 23: Setting the Signal Bar Limit Switch . . . . .	31
Figure 24: Raised Height Adjustment . . . . .	32
Figure 25: Replacement Parts . . . . .	34
Figure 26: Single Phase Control Panel . . . . .	36
Figure 28: Single Phase Combo Control Panel . . . . .	37
Figure 29: Three Phase Combo Control Panel . . . . .	38
Figure 30: Vertical Dock Leveler Control Panel . . . . .	39
Figure 31: Outside Light Replacement Parts . . . . .	40
Figure 32: Replacement Signs . . . . .	41

# PENTALIFT EQUIPMENT CORPORATION WARRANTY

## WARRANTY

**Pentalift Equipment Corporation** expressly warrants that any product manufactured by **Pentalift Equipment Corporation** will be free from defects in material and workmanship under normal use for a period of one (1) year from the date of shipment of the equipment, provided the original purchaser maintains and operates the product in accordance with proper procedures. In the event the product proves defective in material or workmanship, **Pentalift Equipment Corporation** will at its option:

1. Replace the product or the defective portion thereof without charge to the purchaser; or
2. Alter or repair the product; on site or elsewhere, as **Pentalift Equipment Corporation** may deem advisable, without charge to the purchaser.

The warranty stated in the previous paragraph is that expressed by **PENTALIFT EQUIPMENT CORPORATION** AND IS IN LIEU OF ALL GUARANTEES AND WARRANTIES, EXPRESSED OR IMPLIED BY ANYONE OTHER THAN **PENTALIFT EQUIPMENT CORPORATION**. This warranty does not cover any failure caused by improper installation, misapplication, overloading, abuse, negligence, or failure to lubricate and adjust or maintain the equipment properly and regularly. Parts requiring replacement due to damage resulting from abuse, improper operations, improper or insufficient lubrication, lack of proper protection or vehicle impact are not covered by this warranty. **Pentalift Equipment Corporation** assumes no responsibility or liability for:

1. Consequential damages of any kind which result from use or misuse of the equipment.
2. Damage or failure resulting from the use of unauthorized replacement parts.
3. Damage or failure resulting from modification of the equipment.
4. Damage resulting from the misuse of the equipment.

THERE ARE NO WARRANTIES, EXPRESSED OR IMPLIED, WHICH EXTEND BEYOND THE DESCRIPTION ON THE FACE HEREOF, AND THERE IS NO WARRANTY OF MERCHANTABILITY OR OF FITNESS FOR A PARTICULAR PURPOSE.

**Pentalift Equipment Corporation** warranties extend only to the original product itself. In no event shall **Pentalift Equipment Corporation** be responsible for or liable to anyone, including third parties, for special, indirect, collateral, punitive, incidental or consequential damages, even if **Pentalift Equipment Corporation** has been advised of the possibility of such damages. Such excluded damages include, but are not limited to, loss of good will, loss of profits, loss of use, interruption of business or other similar indirect financial loss.

**Pentalift Equipment Corporation** DISCLAIMS all liability arising out of the workmanship, methods and materials used by the installer.

**Pentalift Equipment Corporation** DISCLAIMS all liability for premature product wear, product failure, property damage or bodily injury arising from improper installation and application.

**Pentalift Equipment Corporation** will not accept any warranty for which the original purchaser does not notify **Pentalift Equipment Corporation's** Warranty Department of the defect within ninety (90) days after the product defect is discovered. A fully completed Product Registration Card is required prior to the review or processing of any warranty requests or claims.

WARRANTIES, whether expressed or implied, relating to workmanship and materials used in connection with the installation of **Pentalift Equipment Corporation** products are specifically DISCLAIMED.

WR001R02



P.O. Box 1510, Buffalo, NY, U.S.A. 14240-1510  
Phone: (519) 763-3625 □ FAX (519) 763-2894  
21 Nicholas Beaver Rd, Puslinch, Ontario, N0B 2J0 Canada  
Phone: (519) 763-3625 □ FAX (519) 763-2894

**NOTE:** All Pentalift Equipment Corporation products are subject to design improvement through modification without notice.