



## PENTALIFT EQUIPMENT CORPORATION

# ULTRAHOOK UHR40 VEHICLE RESTRAINT OWNERS MANUAL

### SERIAL NUMBER \_\_\_\_\_

Individual Serial Number(s) must be filled out by the user for future reference.

### **This manual is an important document.**

It shall be kept with the machine or located where readily available to operators and maintenance personnel for reference purposes. Do not install, operate or service this product unless you have read and fully understand the entire contents of this manual. Failure to do so may result in property damage, bodily injury or death. Keep this manual in a safe place for future reference.

**NOTE:** A very high level of field issues with this type of equipment can be directly attributed to improper or incomplete installation. The installation instructions and information provided for this equipment is thorough. A step by step sequence for installation is provided. All steps must be followed and completed to provide a complete installation. Incomplete or improper installations can lead to equipment malfunction and / or damage, create safety issues and void warranties. Please follow all installation and set ups steps as indicated in the installation instructions and owner's manual. If you are unclear or uncertain regarding any of the steps contact your Pentalift representative for clarification. A copy of the completed steps listing with the sign off and photos of the installation as indicated at the conclusion of the installation instructions will be required prior to any Pentalift factory trouble shooting assistance.

**Pentalift Equipment Corporation  
21 Nicholas Beaver Rd  
Puslinch, ON N0B 2J0  
Phone: 519-763-3625  
Fax: 519-763-2894  
Parts Phone: 519-763-3625 Extension 625  
Ask for Parts Department**

**Pentalift Equipment Corporation provides an owners manual when equipment is shipped. Additional manuals are available at \$25.00 each.**

**IMPORTANT:** The owners manuals that are provided on Pentalift Equipment Corporations website are generic in nature. They are provided for general information only. For all purposes, only the owners manual that is specific to the equipment should be referenced and relied on. In order to receive the specific owners manual for specific Pentalift equipment, please contact your Pentalift representative and supply the specific serial number(s) for the equipment the manual is required for. Do not rely on the information in the generic owners manuals provided through the website as it may not be appropriate for your specific Pentalift equipment.

THIS PAGE INTENTIONALLY LEFT BLANK

Generic manual for reference only. Contact Pentlift with product serial number to receive owners manual for your specific equipment.

# PRODUCT REGISTRATION

		<b>PRODUCT REGISTRATION CARD</b>	
To validate warranty and to advise of product updates please complete the following information and return to <b>Pentalift Equipment Corporation</b>			
To validate warranty on-line go to: <a href="http://www.pentalift.com">www.pentalift.com</a>			
<b>END USER INFORMATION</b>			
*Company Name:			
Contact *First Name:	*Last Name:	Title:	
*Mailing Address:			
*City:	*State/Prov.	*Zip/Postal Code:	
*Phone: ( ) -	Fax: ( ) -	Email:	
Check Products Purchased:	<input type="checkbox"/> Levelers, <input type="checkbox"/> Vehicle Restraints, <input type="checkbox"/> Seals/Shelters, <input type="checkbox"/> Elevating Docks, <input type="checkbox"/> Lift Tables		
*Serial Number(s):		Invoice # (if available):	
Dealer Name:		Sales Rep.:	
Manual Verification *Manual Number:			

Please return to:

Pentalift Equipment Corporation  
P.O. Box 1510,  
Buffalo, NY 14240-1510

or

Pentalift Equipment Corporation  
21 Nicholas Beaver Rd  
Puslinch, Ontario  
N0B 2J0

Attention: Service Department

Or Fax to (519) 763-2894

# SAFETY INFORMATION AND WARNINGS



READ THESE SAFETY PRACTICES BEFORE INSTALLING, OPERATING OR SERVICING THE ULTRAHOOK VEHICLE RESTRAINT. FAILURE TO FOLLOW THESE SAFETY PRACTICES MAY RESULT IN PROPERTY DAMAGE, BODILY INJURY OR DEATH.

THE OPERATION OF THIS EQUIPMENT IS SUBJECT TO CERTAIN HAZARDS THAT CAN BE PROTECTED AGAINST ONLY BY THE EXERCISE OF CARE AND COMMON SENSE AND NOT BY MECHANICAL MEANS. IT IS, THEREFORE, ESSENTIAL TO HAVE COMPETENT, QUALIFIED OPERATORS TRAINED IN THE SAFE OPERATION AND CARE OF THIS TYPE OF EQUIPMENT. ALL PERSONNEL MUST COMPLETELY UNDERSTAND THIS SAFETY INFORMATION BEFORE WORKING ON OR NEAR THIS EQUIPMENT.



**DANGER** indicates an imminently hazardous situation which, if not avoided, will result in death or serious injury.



**WARNING** indicates a potentially hazardous situation which, if not avoided, could result in death or serious injury.



**CAUTION**, used with the safety alert symbol, indicates a potentially hazardous situation which, if not avoided, could result in minor or moderate injury.

## NOTICE

**NOTICE** is used to address practices not related to personal injury.



Before doing any installation, maintenance, inspection or trouble shooting, barricade all areas from traffic around the work area inside (and outside if applicable) for safety and post appropriate warning signs.



Arc flash and shock hazard **PPE** (personal protection equipment) required. De-energize equipment before working on or inside. Do not open cover without appropriate PPE. Refer to NFPA 70E for PPE requirements. This panel may contain more than one power source. Hazardous voltage will cause severe injury or death.



Before doing any electrical work, be certain that the power is disconnected with a fused disconnect, properly tagged and locked out. Fused disconnect and lockout device (supplied and installed by others) must meet with all applicable codes and regulations. All electrical work must be performed by a qualified electrician in accordance with all applicable codes and regulations.



It is the responsibility of others to ensure the proper mounting of any wall mounted equipment such as remote power units, control panels and light packages and to ensure that the mounting surface is capable of fully supporting the loads generated by the equipment.



**STAY CLEAR OF THE EQUIPMENT'S OPERATING PATH AT ALL TIMES.**



**THE VEHICLE RESTRAINT IS AN IMPORTANT SAFETY DEVICE. NEVER DISCONNECT POWER TO THE RESTRAINT SYSTEM WHILE THE DOCK IS IN USE. IN THE EVENT OF A POWER FAILURE, BARRICADE THE WORK AREA TO PREVENT USE OF THE DOCK.**

1. Do not load/unload any truck without confirming that the vehicle restraint has securely engaged the truck's rear impact guard and the appropriate signal lights are illuminated as indicated by the operating instructions in the Owners Manual and on the control panel. If the vehicle restraint fails to engage the truck's rear impact guard for any reason, be certain to restrain the truck with appropriate alternate means and to follow the override procedures listed in this manual before proceeding with any loading/unloading.
2. NEVER attempt to load/unload the truck when the **INSIDE RED** light is illuminated.

3. Do not operate, use, maintain or install this equipment if you are impaired in any manner.
4. When not in use, the equipment must always be in the stored position.
5. Regular inspection and maintenance must be performed to keep the equipment in proper operating condition in accordance with the detailed instructions in this manual. (See MAINTENANCE AND LUBRICATION on page 22)
6. Never stand between the dock and a truck.
7. Ensure that the equipment is not used by anyone if you believe that any part of it might be in disrepair (e.g. loose wires, leaking hoses, bent structural members, broken welds, etc.). See Warranty Section on page 35.
8. If you have any questions, contact your immediate supervisor or your authorized Pentalift representative for assistance.

Generic manual for reference only. Contact Pentalift with product serial number to receive owners manual for your specific equipment.

# OWNER RESPONSIBILITY

The Owner's Responsibilities include the following:

- 6.3.1 The owner should recognize inherent danger of the interface between dock and transport vehicle. The owner shall, therefore, train and instruct loading dock operating personnel in the proper use of restraining devices in accordance with information provided in Section 6.1.2.
- 6.3.2 Nameplates, cautions, instructions, posted warnings and communication lights shall not be obscured from the view of loading dock operating personnel or maintenance personnel for whom such warnings are intended (also see 6.1.3 and 6.3.5).
- 6.3.3 Manufacturer's recommended periodic maintenance and inspection procedures in effect at date of shipment shall be followed, and written records of the performance of these procedures should be kept.
- 6.3.4 Restraining devices that are structurally damaged shall be removed from service, inspected by the manufacturer's authorized representative, and repaired as needed before being placed back in service.
- 6.3.5 The manufacturer shall supply replacement nameplates, communication lights, caution or instructional labels, and operating and maintenance manuals upon request of the owner. The owner shall see that all nameplates, communication lights, and caution and instruction markings or labels, are in place and legible and that the appropriate operating and maintenance manuals are provided to users (see also 6.1.3 and 6.3.2).
- 6.3.6 Modifications or alterations of restraining devices shall be made only with written permission of the original manufacturer. These changes shall be in conformance with all applicable provisions of this standard and shall be at least as safe as the equipment was before modification. These changes shall also satisfy all safety recommendations of the original equipment manufacturer for the particular application of the restraint.
- 6.3.7 When industrial vehicles are driven on or off a transport vehicle during loading or unloading operation, the parking brakes on the transport vehicle shall be applied and wheel chocks or another vehicle restraint that provides equal or better protection shall be engaged. Also, whenever possible air-ride suspension systems should have the air exhausted prior to performing said loading or unloading operations.
- 6.3.8 When a vehicle restraint is unable to properly engage a transport vehicle, the user shall activate the applicable communication if so included, or provide an alternate method to address a "not restrained vehicle condition" to alert and or protect the loading dock operating personnel.
- 6.3.9 When selecting a restraining device, it is important to consider not only present requirements but also future plans or adverse environments.
- 6.3.10 The restraint should never be used in a manner not intended by its design. It must also be compatible with the loading dock equipment and other conditions relating to the loading dock area.

**NOTE:** The MH30 Committee recognizes the devices intended to secure a transport vehicle to a loading dock by mechanical means. The NHTSA Standard 49CFR ch.V 571.223 specifies the strength of the rear impact guard and 49 CFR Ch.V 571.224 specifies the size and locations of the rear impact guard. It is, therefore, recommended that users of such positive restraint devices review:

- The means of attachment to the transport vehicle
- The strength of the overall connection
- The proper coordination of the actuation of devices with any signaling system used
- The need to use wheel chocks



Unless specifically agreed to in writing by Pentalift Equipment Corporation at the time the equipment is ordered and prior to the equipment's manufacture, this equipment is sold as a complete package. It is not to be altered, changed or added to in any way or form, in its configuration and function, without the written permission of Pentalift Equipment Corporation.

If requested by a customer, Pentalift Equipment Corporation is not supplying all or some of the power unit and / or control components for the equipment's application. The power unit and controls constitute important safety and functional aspects of the equipment. It is the customer's responsibility to address the operational and safety issues associated with providing the required controls and power units to satisfy the operational and safety requirements of the equipment.

The customer's decision to supply all or some of these components indicates that the customer is taking full responsibility for any and all possible operational, safety and liability issues associated to the product and its configuration. The customer also agrees to absolve Pentalift Equipment Corporation from any and all possible operation, safety and liability issues.

# TABLE OF CONTENTS

PRODUCT REGISTRATION .....	I
SAFETY INFORMATION AND WARNINGS.....	II
OWNER RESPONSIBILITY.....	IV
TABLE OF CONTENTS .....	1
PRECAUTIONARY LABELING .....	2
PRECAUTIONARY LABELING (Cont.) .....	3
INSTALLATION INSTRUCTIONS .....	5
INSTALLATION INSTRUCTIONS.....	7
ELECTRICAL INSTALLATION INSTRUCTIONS .....	12
ELECTRICAL REFERENCE CHART .....	13
ADJUSTMENTS AND TESTING .....	14
INSTALLATION STEPS CONTINUED .....	16
OPERATION AND PERFORMANCE CHECK .....	17
OPERATING INSTRUCTIONS.....	19
DOCK IS READY FOR TRUCK ARRIVAL OR DEPARTURE.....	19
TRANSPORT VEHICLE IN POSITION.....	19
WHAT TO DO IF THE VEHICLE ATTEMPTS TO DEPART WHEN RESTRAINED .....	21
“OVERRIDE MODE” WHEN THE REAR IMPACT GUARD CANNOT BE ENGAGED BY THE RESTRAINT ..	21
MAINTENANCE AND LUBRICATION .....	22
TROUBLE SHOOTING GUIDE .....	25
ERROR CONDITIONS .....	25
MAINTENANCE MODE .....	26
REPLACEMENT PARTS .....	28
MECHANICAL REPLACEMENT PARTS LIST .....	29
CONTROL PANEL REPLACEMENT PARTS LIST.....	30
TRAFFIC LIGHT REPLACEMENT PARTS.....	32
REPLACEMENT SIGNS.....	33
LIST OF ILLUSTRATIONS .....	34
PENTALIFT EQUIPMENT CORPORATION WARRANTY .....	35

# PRECAUTIONARY LABELING

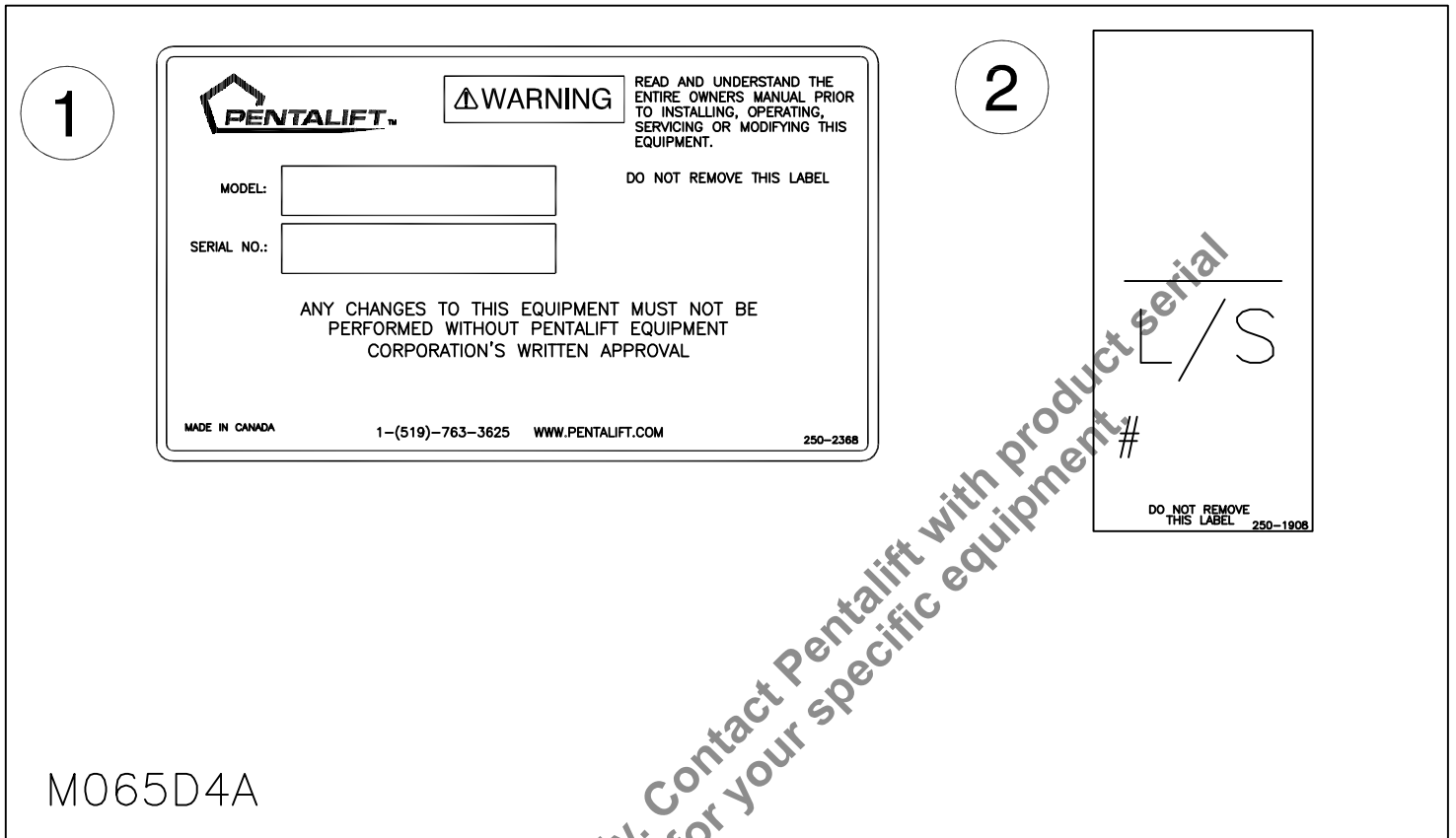

Figure 1: Precautionary Labels

## PRECAUTIONARY LABELING (Cont.)

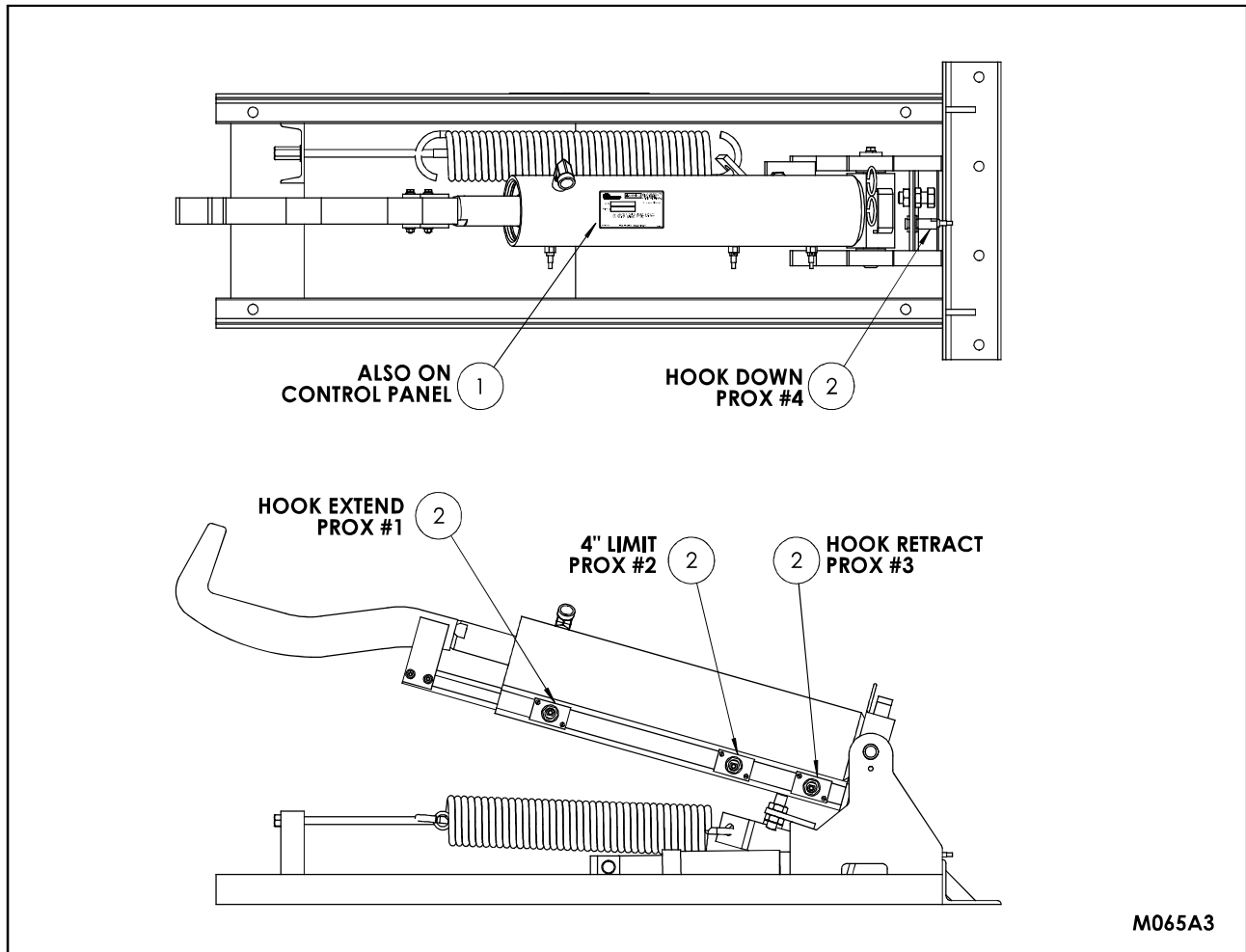

Figure 2: Label Locations

Be sure that all labeling is in place and intact when the unit is received. If any of the precautionary labels or decals are missing or illegible, contact your Pentalift representative for immediate replacement.

**NOTE:** In some instances, product configuration and / or product options may dictate that the product labels will not be placed as indicated on the drawing (Figure 2). Different label locations will be selected at the factory, when required, to avoid an impaired view of the labels. Note the label locations as supplied on the product, when it is received to accommodate future label replacement requirements.

**NOTE:** It is the owner's responsibility to ensure that all precautionary labeling remains legible and in its original position throughout the life of the product. It is also the owner's responsibility to ensure that all labels are and will continue to be readily visible to the operators and people working with or around the equipment. If visibility of any of label is compromised for any reason then; either 1) Rectify the situation to allow the label to be readily visible 2) Order replacement label(s) from Pentalift for installation in a location that does facilitate complete visibility. If any of the precautionary labels are missing or illegible, contact your Pentalift representative for immediate replacement. Inspection shall be done during regular maintenance and lubrication (See MAINTENANCE AND LUBRICATION on page 22).

To re-order labels, use the following part numbers:

<u>Item</u>	<u>Part No.</u>	<u>Qty/Unit</u>	<u>Description</u>
1	250-2368	2	Specification Plate
2	250-1908	4	Proximity Switch Indication Label

**NOTE:** State Model # and Serial # when ordering replacement parts.

Generic manual for reference only. Contact Pentlift with product serial number to receive owners manual for your specific equipment.

# INSTALLATION INSTRUCTIONS



**Do not install, operate or service this product unless you have read and fully understand the entire contents of this manual. Failure to do so may result in property damage, bodily injury or death.**

**NOTE:** A very high level of field issues with this type of equipment can be directly attributed to improper or incomplete installation. The installation instructions and information provided for this equipment is thorough. A step by step sequence for installation is provided. All steps must be followed and completed to provide a complete installation. Incomplete or improper installations can lead to equipment malfunction and / or damage, create safety issues and void warranties. Please follow all installation and set ups steps as indicated in the installation instructions and owner's manual. If you are unclear or uncertain regarding any of the steps contact your Pentalift representative for clarification. A copy of the completed steps listing with the sign off and photos of the installation as indicated at the conclusion of the installation instructions will be required prior to any Pentalift factory trouble shooting assistance.

---

## IMPORTANT

### PREPARATION PRIOR TO INSTALLATION

---

Follow all installation instructions in the precise consecutive order that they are written. If the equipment cannot be installed in the order as outlined below, contact Pentalift Equipment Corporation for written instructions on how to proceed. Do not proceed with an alternate installation method unless written confirmation has been provided by Pentalift Equipment Corporation. To accommodate a complete installation there is a blank space provided beside each numbered step in the installation instructions. Please check off the steps sequentially as they are completed. This will assist in confirming a complete installation.



**Before doing any installation, maintenance, inspection or trouble shooting, barricade all areas from traffic around the work area inside (and outside if applicable) for safety and post appropriate warning signs.**



**Arc flash and shock hazard PPE (personal protection equipment) required. De-energize equipment before working on or inside. Do not open cover without appropriate PPE. Refer to NFPA 70E for PPE requirements. This panel may contain more than one power source. Hazardous voltage will cause severe injury or death.**



**Before doing any electrical work, be certain that the power is disconnected with a fused disconnect, properly tagged and locked out. Fused disconnect and lockout device (supplied and installed by others) must meet with all applicable codes and regulations. All electrical work must be performed by a qualified electrician in accordance with all applicable codes and regulations.**



**MAKE SURE LIFTING AND SLINGING DEVICES ARE OF SUFFICIENT CAPACITY, USED IN THE CORRECT MANNER AND ARE IN GOOD WORKING ORDER. ALL LIFTING, POSITIONING AND INSTALLATION, AS WELL AS THE BREAK-IN AND PERFORMANCE CHECK MUST BE DONE BY QUALIFIED PERSONNEL TRAINED AND EXPERIENCED IN NECESSARY SAFETY PROCEDURES.**



**BE SURE ALL HYDRAULIC FITTINGS ARE RATED FOR HYDRAULIC SYSTEMS THAT MAY PEAK OUT AT 4000PSI. HARDWARE STORE ITEMS CAN BURST AT 150PSI. ONLY BUY REPLACEMENT PARTS FROM PENTALIFT.**



**It is the responsibility of others to ensure the proper mounting of any wall mounted equipment such as remote power units, control panels and light packages and to ensure that the mounting surface is capable of fully supporting the loads generated by the equipment.**

**⚠ WARNING**

THE DOCK LEVELER, WHEN INSTALLED OVER THE ULTRAHOOK, MUST HAVE THE LIFT CYLINDER THRUST BEAM SUPPORTED. A CYLINDER THRUST BEAM SUPPORT IS PROVIDED ON DOCK LEVELERS TO BE INSTALLED WITH A ULTRAHOOK. PRIOR TO INSTALLATION CONFIRM THE DOCK LEVELER IS EQUIPPED WITH THIS OPTION.

**NOTICE**

Never weld on the Ultrahook Vehicle Restraint or dock leveler after sensing switches are wired into the control box and the power to the box is on. Electrical current from the welder can “feedback” through the circuit and damage the motor and other components.

*Generic manual for reference only. Contact Pentalift with product serial number to receive owners manual for your specific equipment.*

# INSTALLATION INSTRUCTIONS

1. \_\_\_ Ensure pit construction has sufficient strength to meet the draw pull forces which will be applied. (See Figure 6: Concrete Loading Diagram for Lagged in Models on page 10.) Further, ensure the dock leveler pit, as well as the restraint pit, meet the pit diagram dimensions as provided by the manufacturer, complete with appropriate conduit(s).
2. \_\_\_ Ensure you have all necessary components as shipped with the unit.
  - \_\_\_ Ultrahook
  - Brush Weather Seal Assemblies
    - brush weather seal carrier x 36" long - 2 pieces
    - face plates 12 Ga x 15-5/8" x 36" long - 2 pieces
  - Sign Package – 4 pieces
  - Electrical Control Panel (common control panel may be shipped with the dock leveler)
  - Power Unit
  - Outside signal lights (may be shipped with the dock leveler)
3. \_\_\_ Clean pit of all debris.
4. \_\_\_ Mark the center line of the pit floor from front to back (see Figure 4: Position the Ultrahook on page 8).
5. \_\_\_ Mark the center line of the Ultrahook frame at the front and back (see Figure 4: Position the Ultrahook on page 8).
6. \_\_\_ Hoist the Ultrahook by slinging through the lifting point at the cylinder pivot and the hook(See Figure 3: Slinging Unit on page 8.)
7. \_\_\_ Position the Ultrahook into the pit, keeping the front of the frame flush with the outside surface of the foundation wall. Align centerlines (front and rear) of the Ultrahook with centerlines of the pit (see Figure 4: Position the Ultrahook on page 8).
8. \_\_\_ Lag the frame to the pit floor using 3/4" lag bolts with a minimum shear value of 10,000 lb and minimum tension value of 10,000 lb. (see Figure 6: Concrete Loading Diagram for Lagged in Models on page 10)
9. \_\_\_ Install the dock leveler following the manufacturer's installation instructions. Raise the dock leveler and secure it in place using the manufacturers maintenance procedure (see the dock leveler Owners Manual). Then disconnect all power supply.
10. \_\_\_ Mount power unit and the signal junction box (by others) in the pit (See Figure 8: Power Unit and Junction Box). Ensure that these components are mounted in a location which ensures they will not make contact with the dock leveler but are close enough to the vehicle restraint to allow the pre-wired proximity and pressure switches to reach the junction box. It is recommended to locate the components toward the rear of the dock leveler pit. This accommodates the fact that the dock leveler deck assembly will move below floor level during operation. Note: The control panel and the power unit are to be located in an area that is clean, dry, and free from exposure to liquids and excessive debris and external weather.
11. \_\_\_ Mount the outside light approximately 90" from the center of the light to finished driveway level (See Figure 7: Mount Outside Light and Signs on page 11).
12. \_\_\_ Mount the mirror image caution sign above the outside light; the normal vision caution sign below the outside light and the "Warning Stand Clear..." sign centered vertically directly to the right of the Ultrahook (See Figure 7: Mount Outside Light and Signs on page 11).
13. \_\_\_ Install the control panel in a location that ensures an unobstructed view at all times. The installation location must ensure the complete legibility of the operating instructions during the operation of all loading dock equipment, including the fork lifts.
14. \_\_\_ Connect all required electrical connections as per appropriate wiring diagram located inside the electrical control panel (See ELECTRICAL INSTALLATION INSTRUCTIONS on page 12).

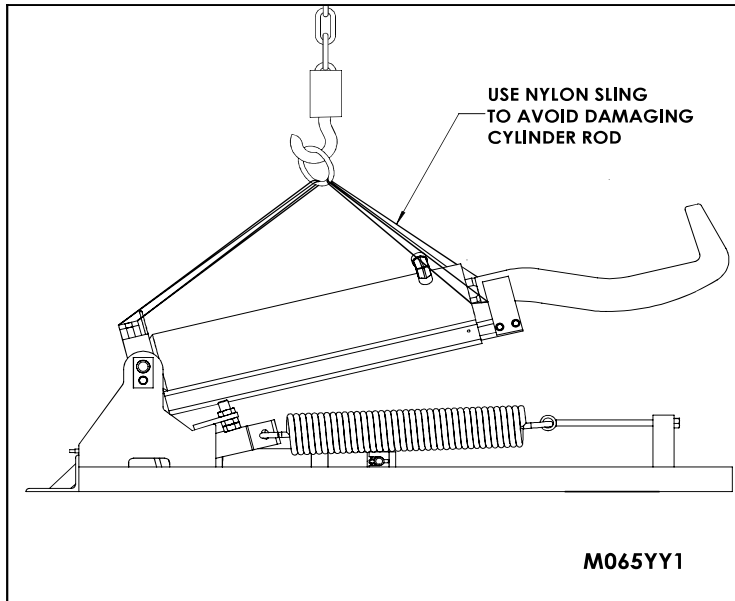

Figure 3: Slinging Unit

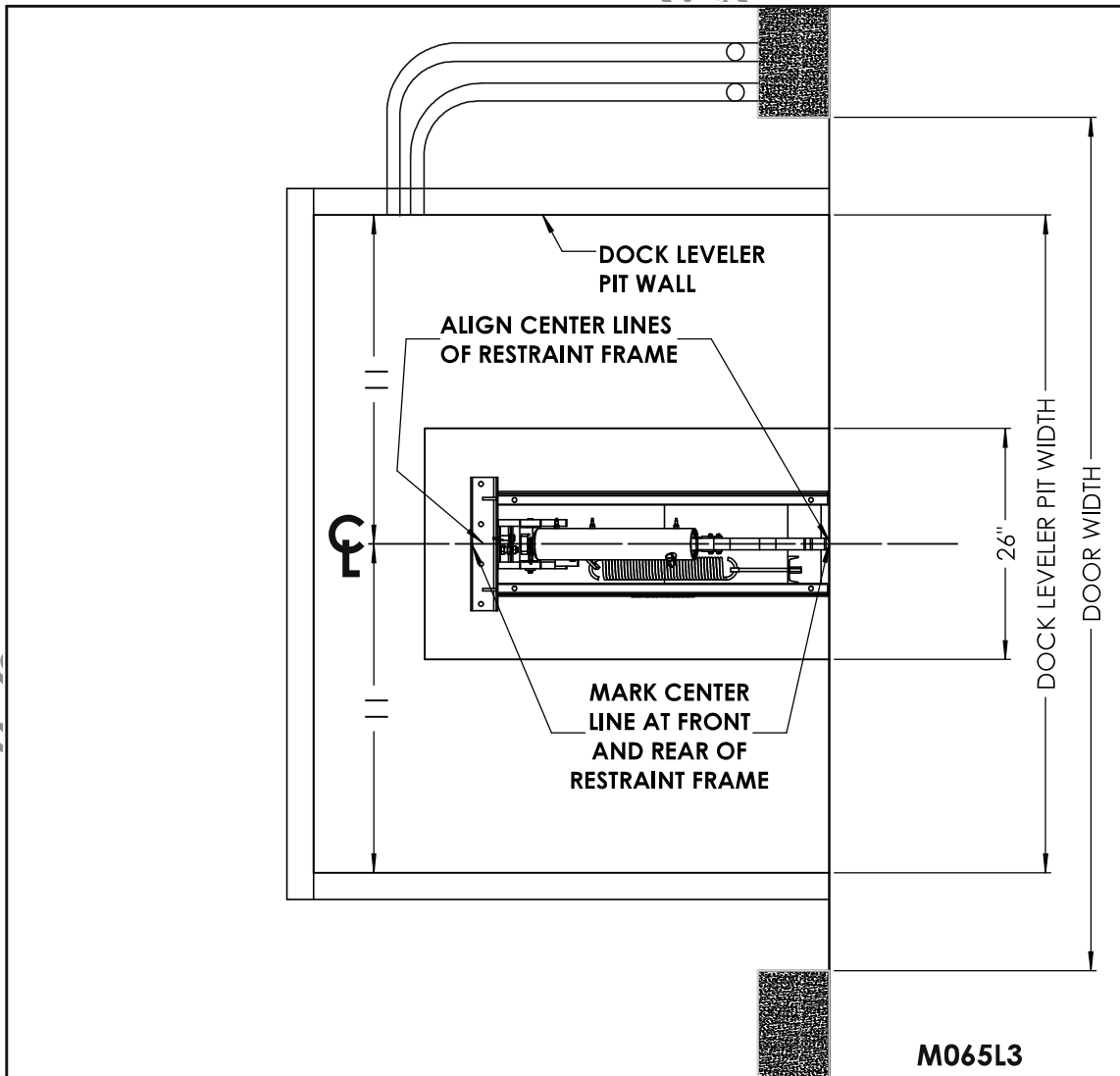

Figure 4: Position the Ultrahook

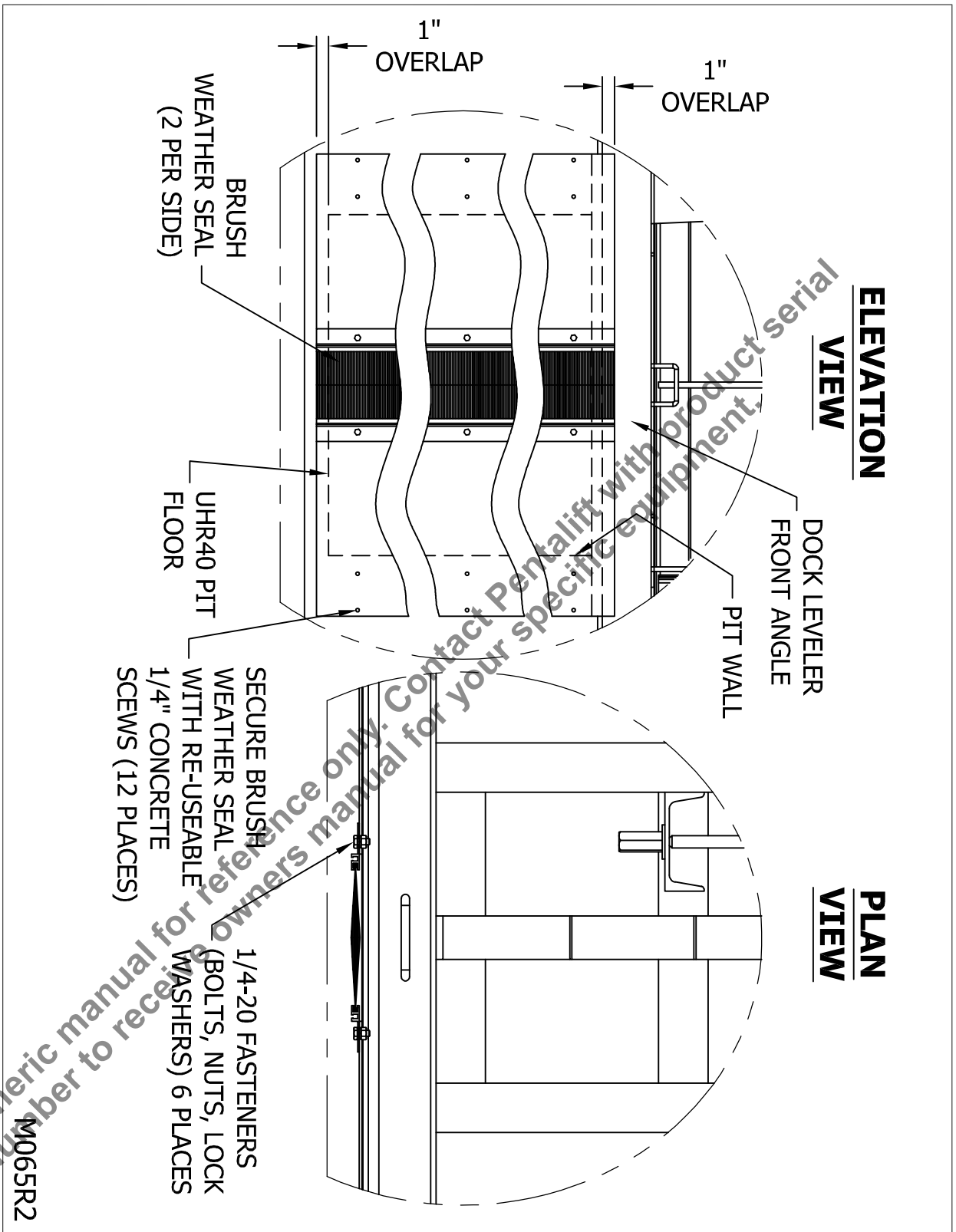

Figure 5: Mounting the Brush Weather Seal

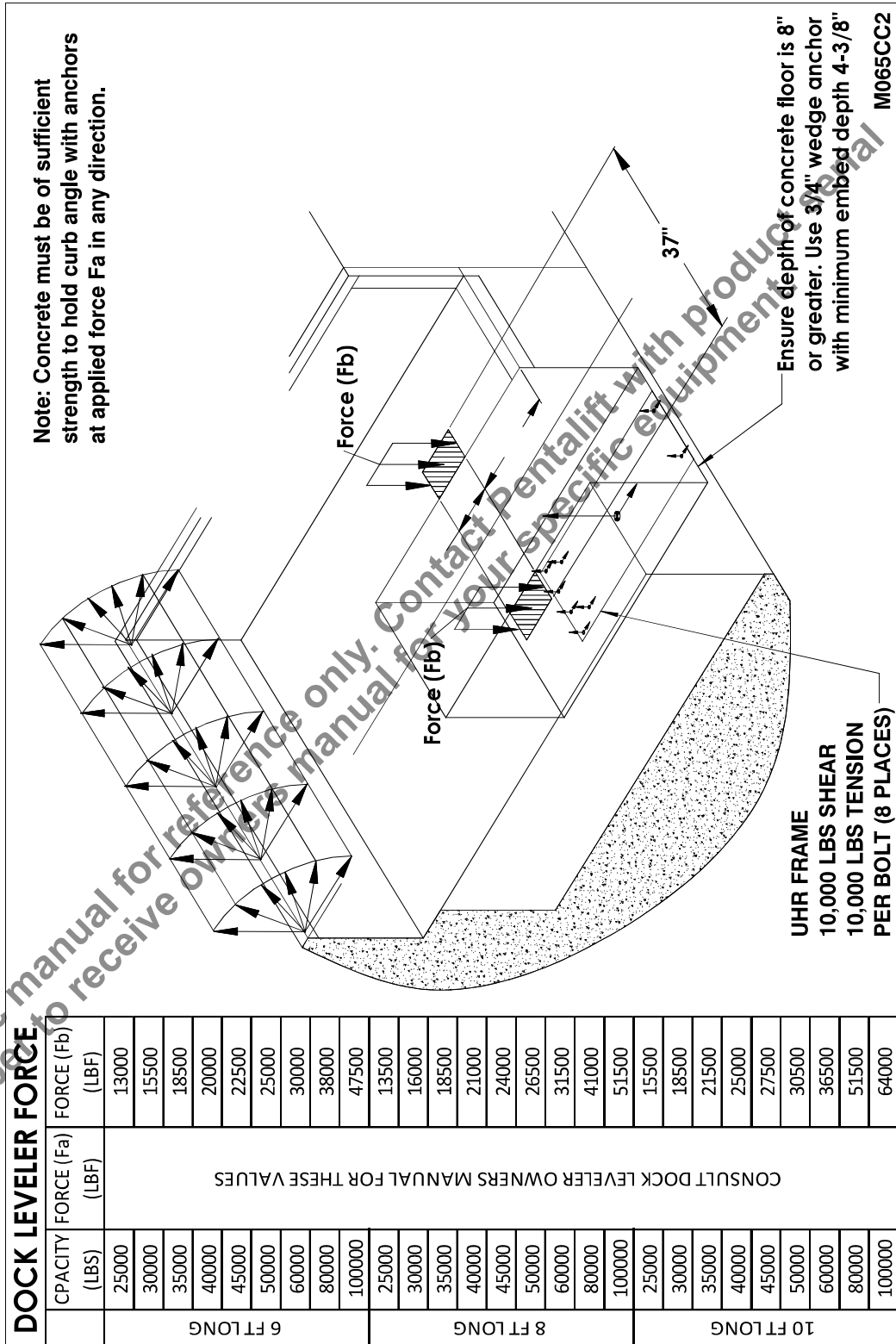

Figure 6: Concrete Loading Diagram for Lagged in Models

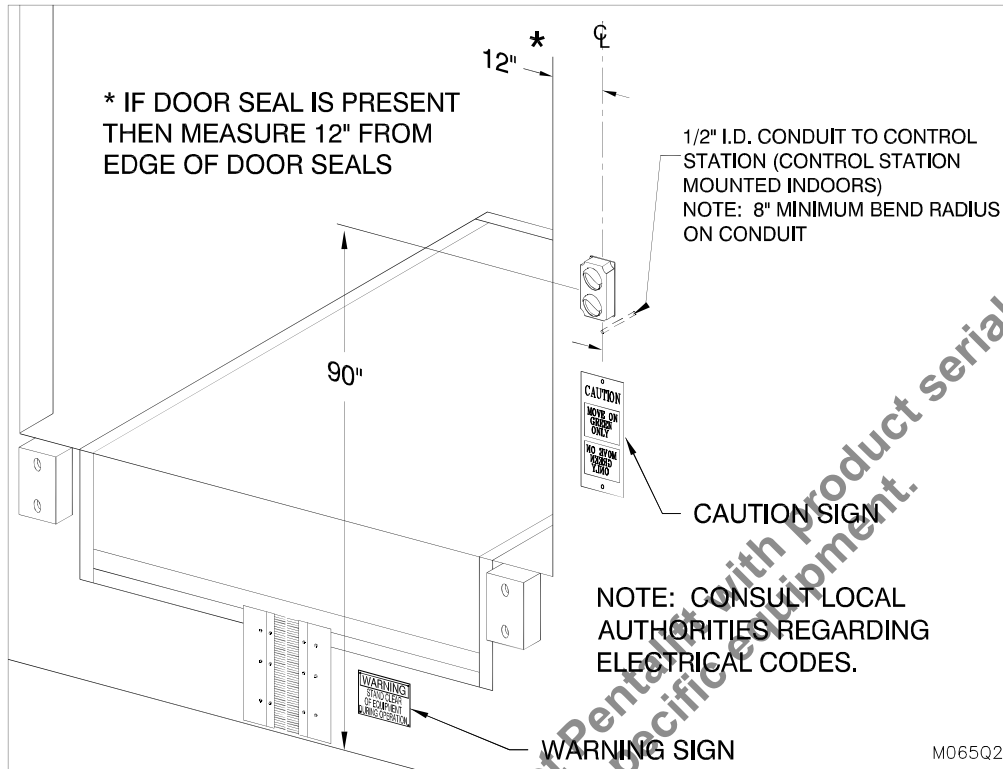

Figure 7: Mount Outside Light and Signs

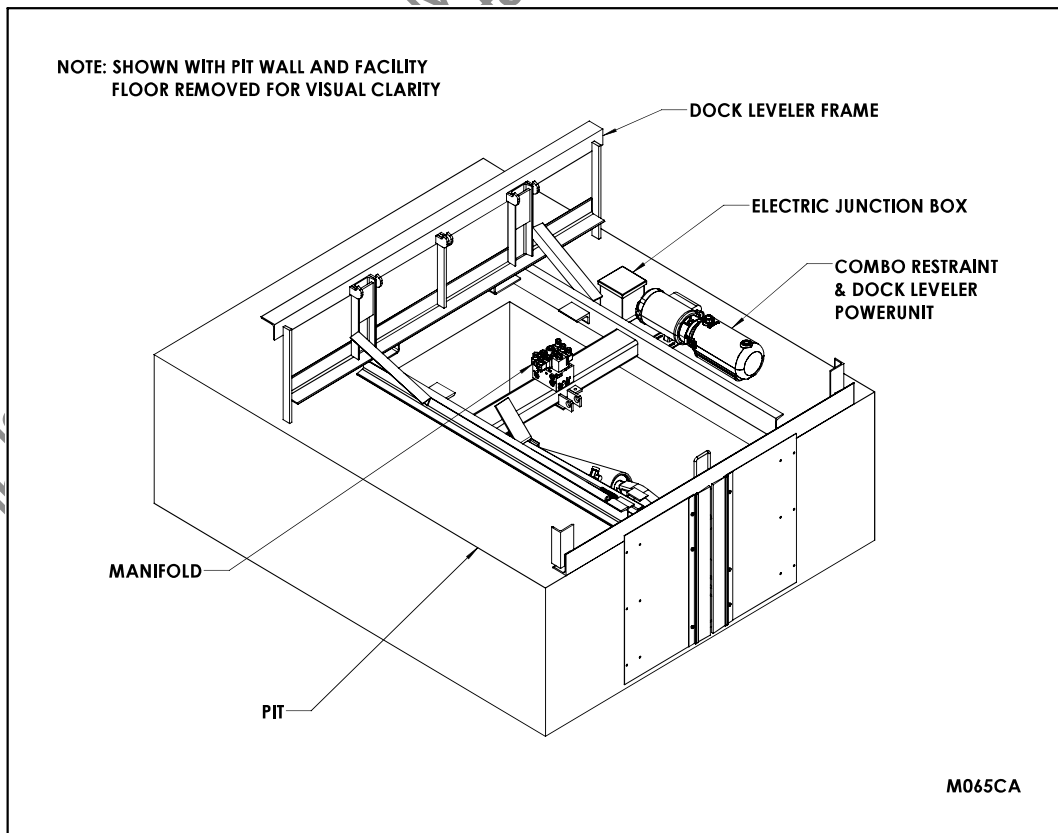

Figure 8: Power Unit and Junction Box

# ELECTRICAL INSTALLATION INSTRUCTIONS



Before doing any electrical work, be certain that the power is disconnected with a fused disconnect, properly tagged and locked out. Fused disconnect and lockout device (supplied and installed by others) must meet with all applicable codes and regulations. All electrical work must be performed by a qualified electrician in accordance with all applicable codes and regulations.



Arc flash and shock hazard PPE (personal protection equipment) required. De-energize equipment before working on or inside. Do not open cover without appropriate PPE. Refer to NFPA 70E for PPE requirements. This panel may contain more than one power source. Hazardous voltage will cause severe injury or death.

**Pentalift Hydraulic Truck Restraint** packages are supplied in four separate components requiring electrical connection, consisting of the power unit, control panel, outside signal lights, and the restraint device. Each item is internally wired at the factory. They must all be connected to each other.

The following instructions apply to standard units:

1. \_\_\_ Carefully examine the restraint components and review the instructions and wiring diagram to determine the tools and supplies that are required for proper installation.
2. \_\_\_ For new construction, conduits must be placed as per the appropriate Pentalift pit drawing. Confirm the conduit locations with the appropriate Pentalift pit drawing.
3. \_\_\_ Run the required wires from the control panel to the signal junction box (by others), restraint power unit junction box, restraint power unit motor, and outside signal lights. Attach these wires to the appropriate terminal strips in the control panel and in the various junction boxes.
4. \_\_\_ Ensure that the motor starter thermal overload is set to match the full load current as shown on the motor name plate. Consult all applicable electrical codes.
5. \_\_\_ Connect the AC power supply line to the control panel.

NOTE: Power unit requires full voltage at motor. Wire size should be sufficiently sized to prevent line voltage drop when the motor is under load.

6. \_\_\_ With power to the control panel, turn the AUTO RETURN and SHELTER switches (if equipped) to OFF and turn the ULTRAHOOK switch to DISENGAGE. Check the indicator lights located on the front face of the PLC. The following indicators must be lit:

- |  |   |
|--|---|
| - PWR (Red LED)                        | - 0C "Hook Fully Retracted" (Green LED) |
| - RUN (Green LED)                      | - 0F "Maintenance Mode" (Green LED)     |
| - 08 "Hook Fully Extended" (Green LED) | - 47 "Outside Green Light" (Green LED)  |
| - 09 "4" from Dock Face" (Green LED)   | - 41 "Inside Red Light" (Green LED)     |

7. \_\_\_ If these indicators are not lit as per step (6), check all connections before proceeding to ADJUSTMENTS AND TESTING on page 14.
8. \_\_\_ Once the electrical connections are completed and the dock leveler is installed, cycle the restraint several times to ensure there is sufficient clearance, the unit is positioned properly and that all proximity switches, the tilt spring and hard stops are adjusted correctly.

9. \_\_\_ Trim the height of the brush weather seal assemblies so that they overlap the 2” step at the bottom front of the restraint by 1” and the dock leveler front angle by approximately 1”. Ensure that the two halves of the brush weather seal assemblies meet at the center of the pit opening. Fasten brush weather seal assemblies to the dock face using 1/4 concrete screws of the type that are removable and re-useable (see Figure 5: Mounting the Brush Weather Seal on page 9). Note: If the trimming operation removes some bolt holes and fasteners, then the cover plate and brush weather seal carrier may need to be re-drilled. This will depend on how much material is removed from the brush weather seal assemblies to suit restraint vertical opening and dock height.
10. \_\_\_ Confirm that all steps of the installation instructions have been completed. Fill out the following information.

\_\_\_\_\_  
**Installer Name (Print)**

\_\_\_\_\_  
**Installer Signature**

\_\_\_\_\_  
**Date Installation Completed**

**ELECTRICAL REFERENCE CHART**

<b>ELECTRICAL REFERENCE - 1.5 HP</b>							
	AWG	115/1/60	230/1/60	230/3/60	380/3/50	460/3/60	575/3/60
Length of branch circuit which will have a 2% voltage drop at full load current (copper wire) ft/m.  The values given are intended to be a rough wiring guide only.  Be sure to check all local electrical codes before wiring.	14		60.3 ft/ 18.4m	168.7 ft/ 51.4m	406.7 ft/ 124m	704 ft/ 214m	1035.1 ft/ 315.5m
	12	38.1 ft/ 11.6m	152.5 ft/ 46.5m	268.2 ft/ 81.8m	646.7 ft/ 197.1m	Note: Calculations are based on 30 degrees C Ambient	
	10	60.6 ft/ 18.5m	242.6 ft/ 73.9m	426.8 ft/ 130.1m			
	8	96.4 ft/ 29.4m	385 ft/ 117.5m	678.2 ft/ 206.7m			
	6	153.2 ft/ 46.7m	612.9 ft/ 186.8m				
<b>Approximate Motor Current (full load) TENV Unit</b>		19 A	9.5 A	5.4 A	3.7 A	2.7 A	2.2 A

## ADJUSTMENTS AND TESTING



**ONLY TRAINED AND QUALIFIED PERSONNEL SHALL PERFORM INSPECTION OR MAINTENANCE AND SERVICE PROCEDURES.**



**Before doing any installation, maintenance, inspection or trouble shooting, barricade all areas from traffic around the work area inside (and outside if applicable) for safety and post appropriate warning signs.**

**NOTE:** This equipment has been fully tested, adjusted and confirmed to be operational at the factory. If, however, some proximity sensors have come out of adjustment during transportation and installation, the following adjustments may be performed by a qualified technician.

### PROXIMITY SENSOR ADJUSTMENTS:

Check and/or adjust proximity sensors #1, #2 and #3 before checking and/or adjusting proximity sensor #4.

If the indicator lights located on the front face of the PLC do not illuminate as indicated in step 6 on page 12, visually inspect for the LED light on the side of the proximity sensor. When the unit is in the "parked" position, proximity sensors #1, #2 and #3 should be lit. If one or more is not lit, complete these steps for each one that is not:

- a) The weather seal may be removed to get a clearer unobstructed view of the hook.
- b) Loosen the jam nut positioning the proximity sensor.
- c) Turn the body of the proximity sensor clockwise to advance it toward the bar until the LED light on the side of the sensor comes on.
- d) Tighten the jam nut positioning the proximity sensor.
- e) Check to ensure the indicator light on the front face of the PLC is also illuminated.

If the sensor body advances until it touches the bar and still the light does not come on, back the sensor body off and recheck all wiring. If you are still unable to adjust the proximity sensor, contact your authorized Pentalift representative.

When proximity sensors #1, #2 and #3 have been confirmed operational, check and adjust proximity sensor #4.



**STAY CLEAR OF THE EQUIPMENT'S OPERATING PATH AT ALL TIMES.**

- a) Put the controls into Maintenance Mode. See MAINTENANCE MODE on page 26.
- b) Manually step the hook forward ("OVERRIDE") and down ("RESET") until you have reached the target position; the recommendation is to have 1/2" of clearance from underside of the hook to the front frame plate or driveway.

### NOTICE

**When in maintenance mode, it is possible to extend the hook without tilting down and this could cause the hook to crash into the frame of the dock leveler. Make these steps slowly and carefully to avoid any possible impacts and damage.**

- c) If the hard stop prevents the hook from reaching close to the frame, loosen the tilt proximity sensor #4 jam nut and back the proximity sensor out, this MUST be done to prevent damage to the proximity sensor. Back off the adjustment bolt to achieve the desired tilt position, then tighten the adjustment bolt jam nut.
- d) If the hard stop does not contact before the hook touches the frame, advance the bolt toward the hook assembly to achieve the desired tilt position.
- e) The proximity sensor must be adjusted to be activated (illuminate the LED light on the side) when the bolt of the hard stop makes contact with the hook assembly. Loosen off the jam nut. Turn the body backwards until the LED light on the side of the proximity switch shuts off. Turn the body forward again until the light illuminates. Turn forward 1/2 turn more. Tighten the jam nut.
- f) When the adjustment is complete, return the restraint to the parked position by turn the 3-position selector switch back to the "DISENGAGE" position to take the controls out of Maintenance Mode.
- g) Test the unit and repeat if necessary. Re-install the weather seal if it was removed.

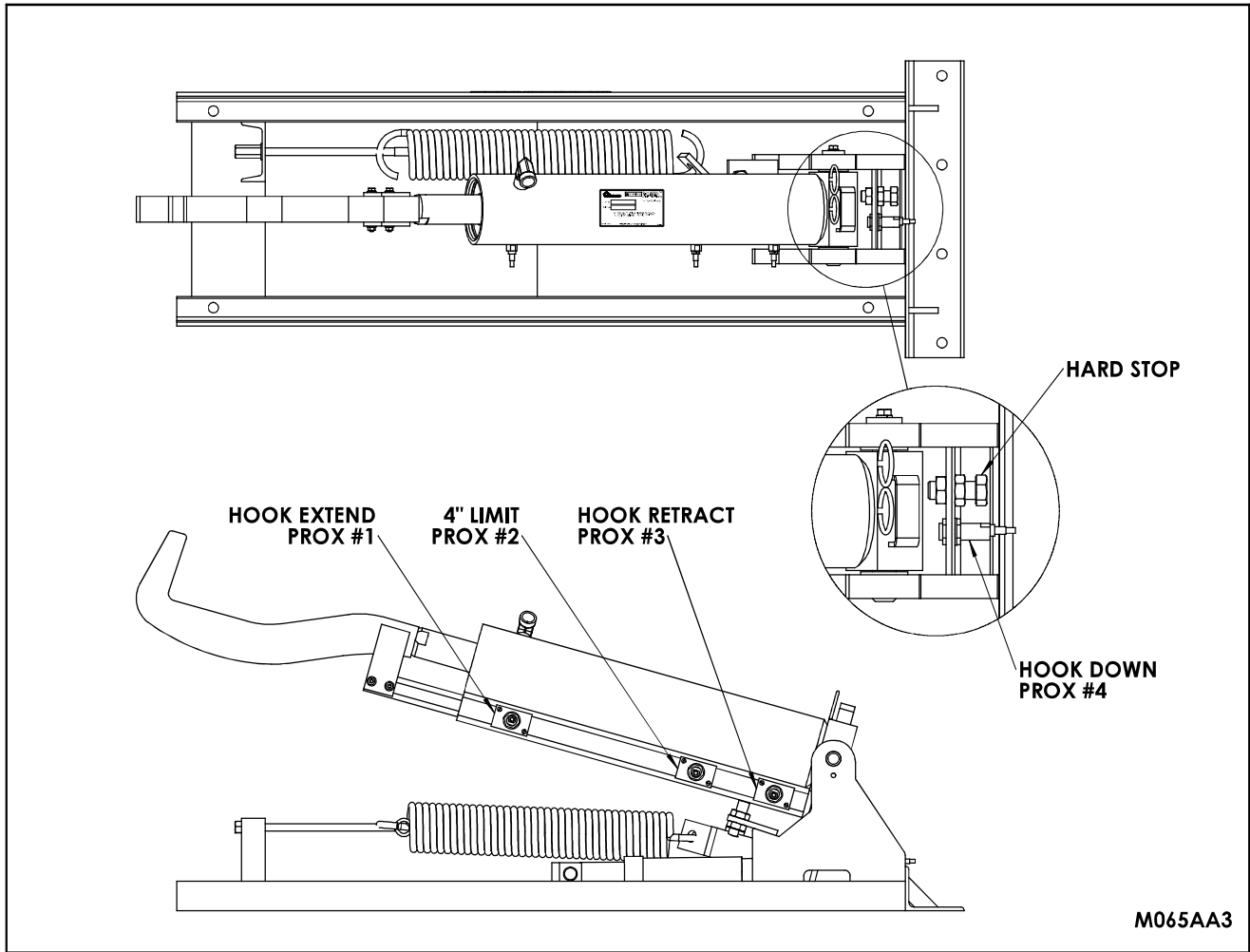

Figure 9: Proximity Switch Adjustments

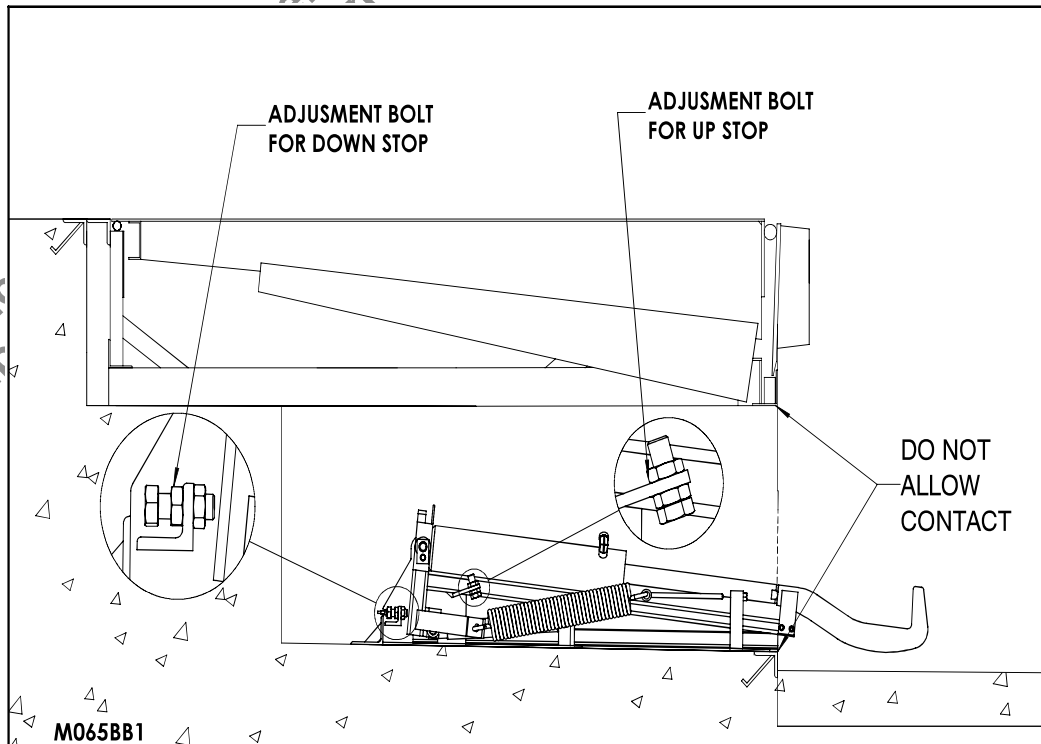

Figure 10: Adjustment Bolts for Tilt Hard Stops

## UP TILT ADJUSTMENTS:

When returning to the stored position, after retracting, the hook will tilt upward. If the hook tilts too far it may hit the underside of the dock leveler. To prevent this, adjust the hard stop by extending the bolt. However, check to ensure that the upper working range is not overly compromised and the majority of truck/trailer's rear impact guard can be engaged.

NOTE: For dock heights below the industry standard of 48", it may not be possible to retain the full operating range of the hook. Check to ensure the hydraulic cylinder fitting does not impact the dock leveler thrust beam assembly.

Tension on the tilt spring will control the force at which the hook will tilt upward. If the hook does not tilt or resists tilting upward when fully extended, you may increase the tension on this spring by turning the adjustment nut toward the spring. This tension in the tilt spring will also affect the upward tilt when the hook is fully retracted and returning to the stored position. Too much tension will cause the tilt to "slam" upward (an audible knock will be heard when the hard stop makes contact). Proper adjustment of the tension in the tilt spring will result in sufficient hook rising force in the extended hook position without excessive raise speed in the retracted hook position.

---

**Installer Name (Print)**

---

**Installer Signature**

---

**Date Installation Completed**

---

## INSTALLATION STEPS CONTINUED

1.  Install the "Warning, Stand Clear of Equipment During Operation" sign. Lag the sign to the foundation wall on driver side. (See Figure 7: Mount Outside Light and Signs Figure 7: Mount Outside Light and Signs on page 11)
2.  Lubricate the pivot points (See MAINTENANCE AND LUBRICATION on page 22).
3.  Installation is complete. Conduct OPERATION AND PERFORMANCE CHECK on page 17 to ensure unit is operating properly.
4.  Confirm that all steps of the installation instructions have been completed. Fill out the following information.

---

**Installer Name (Print)**

---

**Installer Signature**

---

**Date Installation Completed**



**FAILURE TO PROPERLY INSTALL THE ULTRAHOOK MAY RESULT IN PROPERTY DAMAGE, BODILY INJURY OR DEATH AND WILL VOID ALL WARRANTIES.**

## OPERATION AND PERFORMANCE CHECK



Before doing any installation, maintenance, inspection or trouble shooting, barricade all areas from traffic around the work area inside (and outside if applicable) for safety and post appropriate warning signs.



**FAILURE TO CONFIRM THE CORRECT OPERATION OF THE VEHICLE RESTRAINT IN ACCORDANCE WITH THESE INSTRUCTIONS MAY RESULT IN PROPERTY DAMAGE, BODILY INJURY OR DEATH.**

**NOTE:** A very high level of field issues with this type of equipment can be directly attributed to improper or incomplete installation. The installation instructions and information provided for this equipment is thorough. A step by step sequence for installation is provided. All steps must be followed and completed to provide a complete installation. Incomplete or improper installations can lead to equipment malfunction and / or damage, create safety issues and void warranties. Please follow all installation and set ups steps as indicated in the installation instructions and owner's manual. If you are unclear or uncertain regarding any of the steps contact your Pentalift representative for clarification. A copy of the completed steps listing with the sign off and photos of the installation as indicated at the conclusion of the installation instructions will be required prior to any Pentalift factory trouble shooting assistance.

### **THIS OPERATION AND PERFORMANCE CHECK MUST BE PERFORMED PRIOR TO THE INITIAL USE OF THE RESTRAINT AND THEREAFTER ON A DAILY BASIS:**

1. There are four proximity switches employed on the equipment - sensor#1 (hook extend), sensor#2 (rear impact guard not engage), sensor#3 (hook retract) and sensor#4 (hook down). Confirm proximity sensors are properly set up (see ADJUSTMENTS AND TESTING on page 14).
2. With no vehicle docked, ensure the hook is in the stored position (fully back and tilted up) and the 3-position selector switch is in the "DISENGAGE" position. The inside red light must be illuminated and the outside green light must be illuminated. No other lights must be illuminated.
3. Turn the 3-position selector switch to the "ENGAGE" position. The hook must tilt down to the fully lowered position then extend outward. When the hook begins to move, the outside red light must illuminate. Once the hook is fully extended, the hook must fully tilt up, then retract towards the dock leveler, then stop approximately four inches (4") away from the dock face. The alarm must sound continuously and the inside red panel light must flash slowly. No other lights must be illuminated.
4. To clear the missed rear impact guard error alarm, turn the selector switch to "DISENGAGE". (Note: For any other error, all functions cease until the "RESET" button has been pushed. See TROUBLE SHOOTING GUIDE on page 25). The restraint will return to the stored position by turning the 3-position selector switch to the "DISENGAGE" position. The inside red light must be illuminated as soon as the switch is turned, however, the outside red light must remain illuminated until the hook has finished moving to the stored position. Once the hook has fully returned to the stored position and stopped moving, the outside green light must illuminate. No other lights must be illuminated.
5. Turn the 3-position selector switch to the "OVERRIDE" position. (This will allow the dock leveler to operate independently of the restraint.) The inside red light must turn off and the inside yellow light must illuminate. The outside red light must remain illuminated. No other lights must be illuminated.
6. Turn the 3-position selector switch back to the "DISENGAGE" position.
7. Properly position a transport vehicle at the dock. The vehicle must be centered in front of the dock and backed firmly against both dock bumpers. Turn the 3-position selector switch to the "ENGAGE" position. The hook must fully tilt down, then extend outward. When the hook begins to move, the outside red light must illuminate. Once the hook is fully extended, the hook must tilt up stopping once contact is made with the truck/trailer's rear impact guard and then retract towards the truck rear impact guard. When the hook has engaged and secured the truck rear impact guard, the hook movement will stop and the inside green light must illuminate.

No other inside lights must be illuminated. Confirm that the dock leveler will only function when the restraint has engaged the truck rear impact guard.

8. To unhook the vehicle, turn the "ULTRAHOOK" 3-position selector switch to the "DISENGAGE" position. The inside red light must illuminate. The hook must then move a short distance outward to clear the rear impact guard and then down. Once the hook is clear of the rear impact guard and is fully tilted down, the hook must then retract and return to the stored position. When the hook has fully returned to the stored position, the outside green light must illuminate. No other inside lights must be illuminated.

The above steps describe and confirm the correct operation of this important piece of safety equipment. If the unit you have does not meet the requirements listed above, discontinue its use and/or repair it immediately. See the TROUBLE SHOOTING GUIDE section on page 25 to correct the problems or contact your Pentalift representative for any required assistance.

9. Replace burnt out light bulbs on the control panel or defective LED modules immediately.
10. Clean pit of debris.

Generic manual for reference only. Contact Pentalift with product serial number to receive owners manual for your specific equipment.

## OPERATING INSTRUCTIONS



USE BY UNTRAINED PEOPLE CAN RESULT IN PROPERTY DAMAGE, BODILY INJURY OR DEATH. READ, KNOW AND OBEY ALL OPERATING INSTRUCTIONS AND SAFETY INFORMATION. PRIOR TO ENGAGING THE RESTRAINT, THE TRUCK/TRAILER MUST BE CENTERED AND PARKED TIGHT AGAINST THE FACE OF BOTH DOCK BUMPERS. INSPECT AND TEST OUTSIDE LIGHTS, INSIDE LIGHTS AND ALARM DAILY (FOLLOWING THE OPERATION AND PERFORMANCE CHECK ON PAGE PAGE 17). OBEY ALL INSTRUCTIONS, LABELS AND SIGNS PROVIDED WITH THE VEHICLE RESTRAINT.



THE VEHICLE RESTRAINT IS AN IMPORTANT SAFETY DEVICE. NEVER DISCONNECT POWER TO THE RESTRAINT SYSTEM WHILE THE DOCK IS IN USE. IN THE EVENT OF A POWER FAILURE, BARRICADE THE WORK AREA TO PREVENT USE OF THE DOCK.

**NOTE:** It is common for this product to be supplied in combination with other Pentalift Products. When the product supplied with other Pentalift products it is quite common for a combination control panel to be provided. The combination control panel will be a single control panel from which more than one product will be controlled and operated. If your installation incorporates the use of such a common control panel then read and follow all the instructions on the panel. If the instructions on the control panel conflict with instructions in this manual then follow the instructions on the control panel.

### DOCK IS READY FOR TRUCK ARRIVAL OR DEPARTURE

The vehicle restraint is retracted in the stored position. The interior panel-mounted red light is illuminated and the exterior wall-mounted green light is illuminated. Note: The 3-position selector switch must be in the “**DISENGAGE**” position.

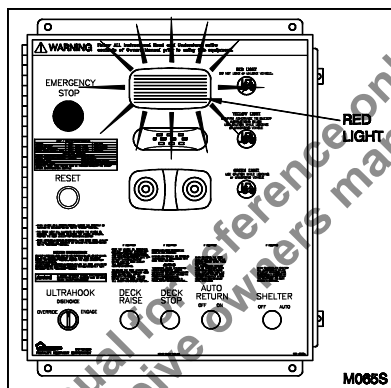

Figure 11: Inside Red Light

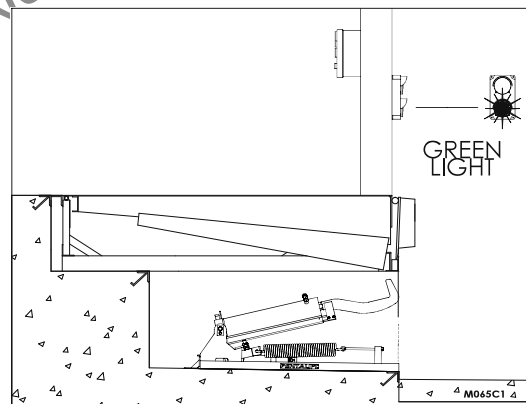

Figure 12: Loading Dock Vacant

### TRANSPORT VEHICLE IN POSITION

1. Confirm that the truck is centered on the loading dock and is backed firmly against both dock bumpers.
2. Turn the 3-position selector switch to “**ENGAGE**”. The exterior wall-mounted red light illuminates informing the truck driver not to depart. The restraint hook lowers, fully extends, rises and retracts until the rear impact guard has been engaged. The interior panel-mounted green light will illuminate.
3. Visually confirm that the restraint hook has properly engaged the rear impact guard before loading / unloading commences.

When loading/unloading frequently check the control panel green light is illuminated. When loading / unloading is complete, turn the 3-position selector switch to the “**DISENGAGE**” position. The interior panel-mounted red light will illuminate, the restraint hook will fully retract to its stored position and the exterior green light will illuminate indicating that the vehicle is free to depart.

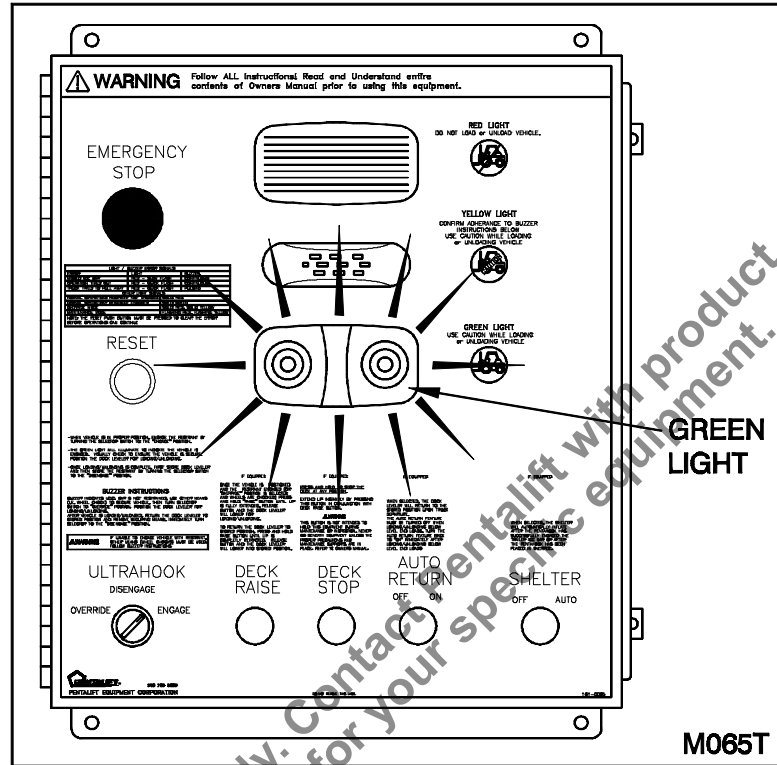

Figure 13: Inside Green Light

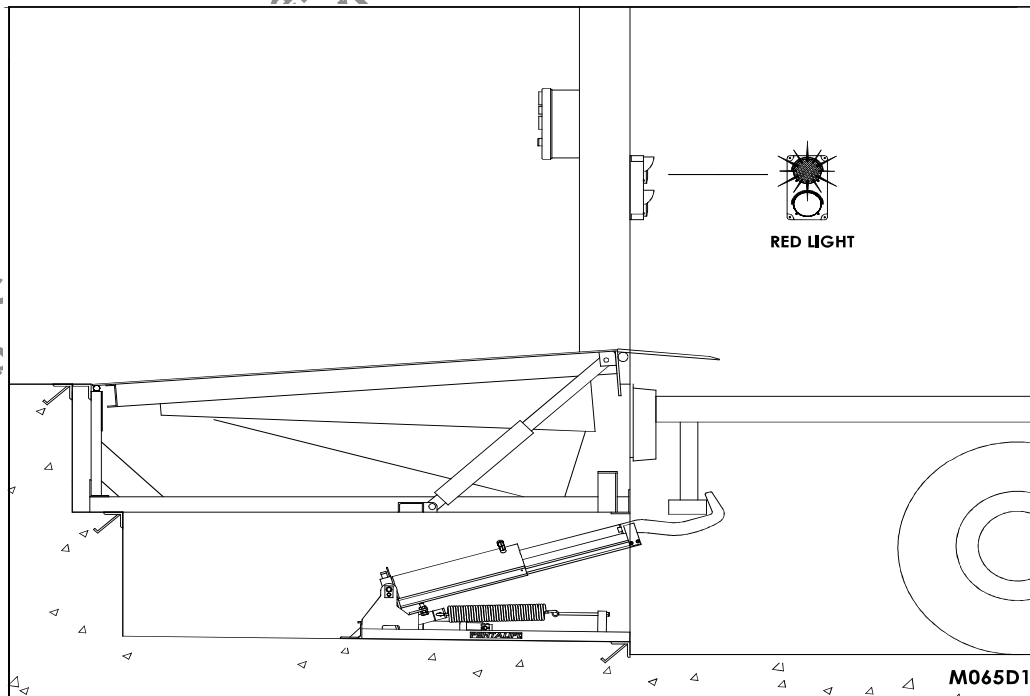
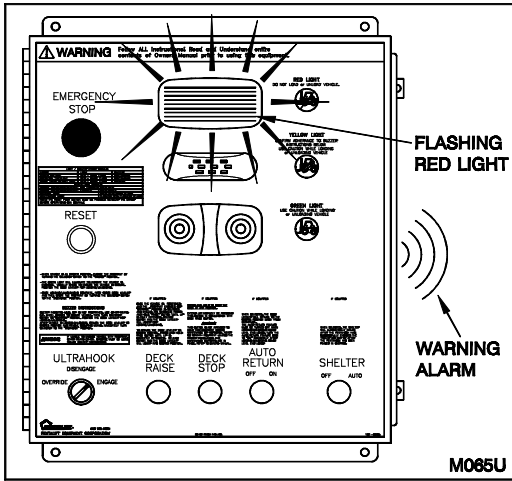

Figure 14: Trailer in Position and Rear Impact Guard Secured

## “OVERRIDE MODE” WHEN THE REAR IMPACT GUARD CANNOT BE ENGAGED BY THE RESTRAINT

If the restraint member moves to within 4 inches of the front face of the pit without engaging the rear impact guard, an error condition occurs. When an error condition occurs, the exterior wall-mounted red light will remain illuminated, the interior panel-mounted red light will flash and the alarm will sound.



**Figure 15: Inside Red Light Flashes and Alarm Sounds**

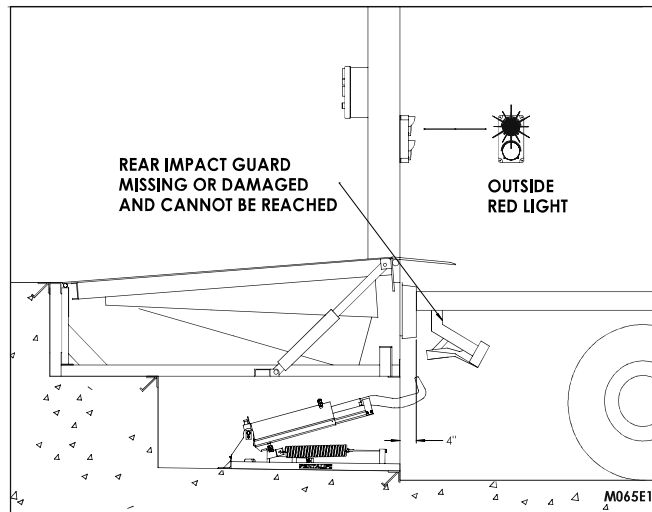

**Figure 16: Rear Impact Guard Not Secure**

Turn the 3-position selector switch to “DISENGAGE” to return the restraint to the stored position.

If engagement by the hook is not made and the trailer can not be repositioned to accommodate engagement, turn the 3-position selector switch to the “OVERRIDE” position. The outside wall-mounted red light will remain illuminated and the interior panel-mounted yellow light will illuminate, warning the operator to proceed with caution. SECURE THE TRAILER BY OTHER MEANS (i.e. wheel chocks).

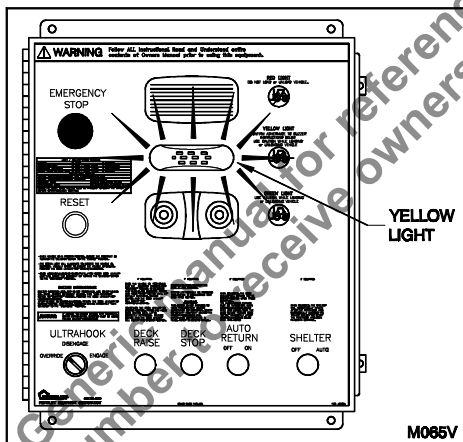

**Figure 17: Inside Yellow Light**

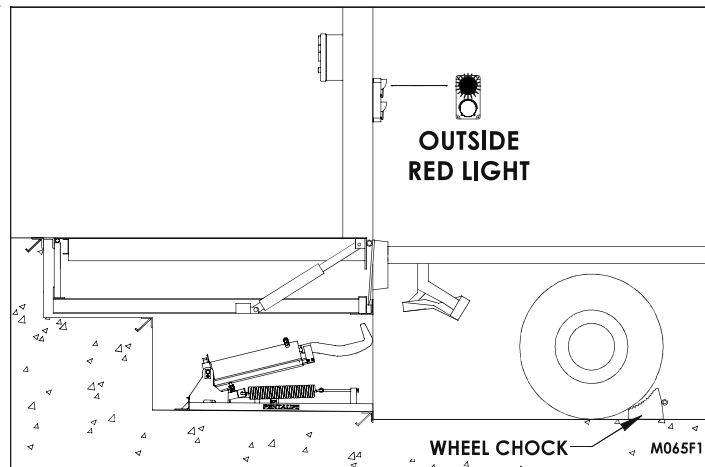

**Figure 18: Secure Trailer by Other Means (i.e. Wheel Chocks)**

Note: For all other errors, the operator must first press the “RESET” button before operations can be resumed. (See ERROR CONDITIONS on page 25.)

## WHAT TO DO IF THE VEHICLE ATTEMPTS TO DEPART WHEN RESTRAINED

If the truck/trailer attempts to drive away while the Ultrahook is still engaged, a pulsing error alarm will sound and the interior panel-mounted red light will begin to flash quickly. Halt the truck/trailer and return it to the dock face. Clear the error by pressing the “RESET” button. Turn the 3-position selector switch to “DISENGAGE” before allowing the truck to depart.

# MAINTENANCE AND LUBRICATION



**ONLY TRAINED AND QUALIFIED PERSONNEL SHALL PERFORM INSPECTION OR MAINTENANCE AND SERVICE PROCEDURES.**



**Before doing any installation, maintenance, inspection or trouble shooting, barricade all areas from traffic around the work area inside (and outside if applicable) for safety and post appropriate warning signs.**



**Arc flash and shock hazard PPE (personal protection equipment) required. De-energize equipment before working on or inside. Do not open cover without appropriate PPE. Refer to NFPA 70E for PPE requirements. This panel may contain more than one power source. Hazardous voltage will cause severe injury or death.**



**Before doing any electrical work, be certain that the power is disconnected with a fused disconnect, properly tagged and locked out. Fused disconnect and lockout device (supplied and installed by others) must meet with all applicable codes and regulations. All electrical work must be performed by a qualified electrician in accordance with all applicable codes and regulations.**



**THE RELIEF VALVE ON THE POWER UNIT IS PRESET AT THE FACTORY. IT IS AN IMPORTANT SAFETY DEVICE. DO NOT ADJUST OR REMOVE THE RELIEF VALVE.**

**NOTE:** A very high level of field issues with this type of equipment can be directly attributed to improper or incomplete installation. The installation instructions and information provided for this equipment is thorough. A step by step sequence for installation is provided. All steps must be followed and completed to provide a complete installation. Incomplete or improper installations can lead to equipment malfunction and / or damage, create safety issues and void warranties. Please follow all installation and set ups steps as indicated in the installation instructions and owner's manual. If you are unclear or uncertain regarding any of the steps contact your Pentalift representative for clarification. A copy of the completed steps listing with the sign off and photos of the installation as indicated at the conclusion of the installation instructions will be required prior to any Pentalift factory trouble shooting assistance.

UNLESS OTHERWISE NOTED, THE FOLLOWING MAINTENANCE AND INSPECTION PROCEDURES SHOULD BE CONDUCTED AT A MINIMUM OF EVERY 30 DAYS. INCREASE FREQUENCY FOR MORE SEVERE ENVIRONMENTS.

**NOTE:** Read the **SAFETY INFORMATION AND WARNINGS** before servicing the Ultrahook vehicle restraint. (See page II.)

**NOTE:** It is the owner's responsibility to assure that all labeling remains legible and in its original position throughout the life of the product. (See **PRECAUTIONARY LABELING** on page 2)

**NOTE:** Inspect equipment for protective coatings (i.e. paint) that have deteriorated or been removed. Prepare affected area and reapply protective coating as required using Tremclad High Performance Rust Enamel (Gloss Dark Machine Grey).

**NOTE:** At every maintenance interval, inspect the vehicle restraint for any damaged or worn parts. If any damaged or worn parts are found, discontinue use of the vehicle restraint and/or repair immediately.

Due to the continuous duty of dock traffic light systems and the importance, daily inspection of the light system should be performed. Spare light bulbs and an LED module should be kept on hand at all times for immediate replacement. Ensure that the proper lens color is in the proper position after checking bulbs and LED modules. Replace burnt out light bulbs on the control panel or defective LED modules immediately.

Check the condition of the brush weather seal. If the brush is worn, consult your authorized Pentalift representative for replacement parts. See **MECHANICAL REPLACEMENT PARTS LIST** on page 29.

**LUBRICATION:** As shown by Figure 19: Lubrication Points on page 23, the indicated pivot points of the Vehicle Restraint must be lubricated regularly to help maintain the unit in proper working condition. The recommended lubrication **service interval is every 30 days** or at a greater frequency as required in severe environments.

**Hydraulic Oil:** The oil should be changed once a year under normal operating conditions. The oil level, however, should be checked weekly. When the hook is fully retracted, the oil level in the reservoir should be approximately 2 - 3 inches from the top.

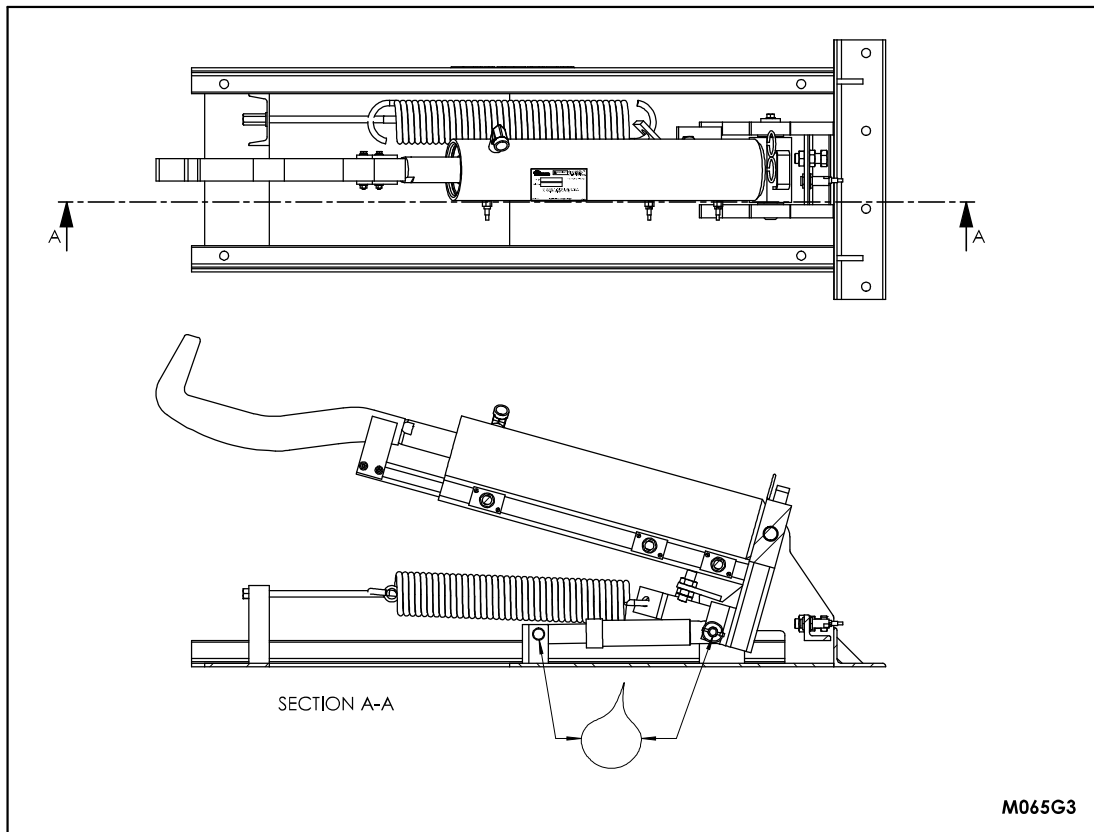

**Figure 19: Lubrication Points**

**NOTICE: HYDRAULIC FLUID**

The standard hydraulic oil supplied with the equipment is HVI-22 Hydraulic fluid. This fluid is suitable for use from approximately -30° C (-22F) minimum to +35°C (+95°F) unless otherwise specified on the specific equipment order. The equipment can be operated in temperatures slightly higher and lower than the temperatures stated on an intermittent basis. Operating the equipment for extended periods of times at temperatures higher or lower than the stated temperatures above may result in functional issues for the equipment. It may also result in damage and issues to hydraulic components. As the actual temperature the equipment is used in moves further away from the recommended temperature range the concern points increase. Abuse and overuse in this regard will void all warranty.

The standard replacement Hydraulic Fluid is HVI-22 hydraulic fluid which accommodates the temperature range stated above. There are special hydraulic fluids available to accommodate temperatures that are consistently and or significantly lower or higher than those stated above. In many cases the use of these types of specialty fluids will result in the requirement for hydraulic fluid changes during seasonal yearly temperature changes.

Recommended for colder temperatures is Hydraulic Fluid 5606A

If the hydraulic oil provided from the factory is non-standard, refer to the hydraulic reservoir fluid label which will specify the particular oil requirements.

**Note:** When approaching or operating in temperature beyond the high and low temperature ranges of the ratings for the hydraulic fluids, there may be some adverse effects to the functionality of the equipment. This could include (but not be limited to) harmonics and vibration of cylinders, inhibited or reduced equipment performance and function, slower cycle times, hydraulic leaks unwanted activation of velocity fuses. To address concerns of this nature a change in hydraulic fluid or a special oil additive maybe required. Contact your Pentalift representative for more information.

**Note:** The remote installation location of the hydraulic power unit can also help address concerns with hydraulic fluid temperature ranges. For example if the equipment is purchased with a remote power unit, the power unit can be installed in a warmer (indoor) location. In this arrangement, even though the main equipment and it's hydraulic components maybe exposed to more extreme temperatures, the hydraulic power unit and the hydraulic fluid stored in it will be exposed to and therefore absorb the more moderate and desirable internal temperature. During operation the oil in the power unit will quickly mix with the oil in the equipment and will typically mix to a more desirable temperature level.

**Note:** If the hydraulic power unit is installed in a pit, as is usually the case for dock levelers, the pit will have moderating effect on the temperature the hydraulic power unit is exposed to. This should be part of the consideration of hydraulic fluid selection.

Generic manual for reference only. Contact Pentlift with product serial number to receive owners manual for your specific equipment.

# TROUBLE SHOOTING GUIDE

**NOTE:** This equipment has been fully tested and confirmed to be operational at the factory. Historically, the majority of operating problems are caused by unnecessary tampering by unqualified personnel. To conform to the terms of the Warranty, contact your authorized Pentalift representative if you are having any difficulty with the restraint during the warranty period. Do not risk voiding the warranty by tampering with the equipment.

**⚠ DANGER** ONLY TRAINED AND QUALIFIED PERSONNEL SHALL PERFORM INSPECTION OR MAINTENANCE AND SERVICE PROCEDURES.

**⚠ DANGER** THE RELIEF VALVE ON THE POWER UNIT IS PRESET AT THE FACTORY. IT IS AN IMPORTANT SAFETY DEVICE. DO NOT ADJUST OR REMOVE THE RELIEF VALVE.

**⚠ DANGER** Before doing any installation, maintenance, inspection or trouble shooting, barricade all areas from traffic around the work area inside (and outside if applicable) for safety and post appropriate warning signs.

**⚠ DANGER** Before doing any electrical work, be certain that the power is disconnected with a fused disconnect, properly tagged and locked out. Fused disconnect and lockout device (supplied and installed by others) must meet with all applicable codes and regulations. All electrical work must be performed by a qualified electrician in accordance with all applicable codes and regulations.

**⚠ DANGER** Arc flash and shock hazard PPE (personal protection equipment) required. De-energize equipment before working on or inside. Do not open cover without appropriate PPE. Refer to NFPA 70E for PPE requirements. This panel may contain more than one power source. Hazardous voltage will cause severe injury or death.

**NOTICE** See page 23 for recommended hydraulic oil.

**NOTE:** A very high level of field issues with this type of equipment can be directly attributed to improper or incomplete installation. The installation instructions and information provided for this equipment is thorough. A step by step sequence for installation is provided. All steps must be followed and completed to provide a complete installation. Incomplete or improper installations can lead to equipment malfunction and / or damage, create safety issues and void warranties. Please follow all installation and set ups steps as indicated in the installation instructions and owner's manual. If you are unclear or uncertain regarding any of the steps contact your Pentalift representative for clarification. A copy of the completed steps listing with the sign off and photos of the installation as indicated at the conclusion of the installation instructions will be required prior to any Pentalift factory trouble shooting assistance.

## ERROR CONDITIONS FLASHING LIGHTS / ALARM SOUNDS

When an error condition occurs, an error alarm sounds and the panel lights flash. For Error #1, the operation may be reset by turning the selector switch to "DISENGAGE". For all other errors, the operator must press the "RESET" button before operations can be resumed. The operator should investigate the cause of the error before clearing the error condition. The red panel light and alarm sound helps to indicate the problem by how they flash and sound:

LIGHT / ALARM ERROR SIGNALS CHART			
#	ERROR	LIGHT DISPLAY	ALARM
1	A MISSED REAR IMPACT GUARD	RED - SLOW FLASH	CONTINUOUS
2	B OPERATION TIMED OUT	RED - FAST FLASH	CONTINUOUS
3	C VEHICLE ATTEMPTED TO PULL AWAY WHILE RESTRAINED	RED - FAST FLASH	PULSING

Three possible error conditions can occur during the operation of the Ultrahook:

- A The most common of these is the **failure to engage the truck rear impact guard**. This condition is detected by the activation of a proximity switch when the hook reaches approximately 4" from the dock face during the retraction. See "OVERRIDE MODE" WHEN THE REAR IMPACT GUARD CANNOT BE ENGAGED BY THE RESTRAINT on page 21.
- B If the **vehicle attempts to drive away while the restraint is still engaged**, see WHAT TO DO IF THE VEHICLE ATTEMPTS TO DEPART WHEN RESTRAINED on page 21.
- C **TIME OUT** errors occur when the desired operation takes too long to complete. If such an error occurs, check the operating path (the area in which the Ultrahook moves) for debris or obstructions. Ensure that the power unit has oil and that all hose fittings and connections are tight. Time out errors may also be caused by proximity switch failure. Confirm all proximity switch circuits against PLC inputs. Refer to the electrical schematic / ladder logic for a listing of PLC inputs and outputs. The electrical schematic / ladder logic can be found inside the control panel.

## MAINTENANCE MODE

The Ultrahook has a maintenance mode designed for use by trained service staff only. It allows the Ultrahook to be tilted, extended or retracted independently. The service technician must open the control panel and locate the junction terminal with the yellow tab labelled MS in its center. The tab is hinged and acts as a blade-style, normally-closed switch. Using a small screw-driver or ballpoint pen, pull the tab out to place the unit in maintenance mode. Once the unit is in maintenance mode, the functions are as follows:

Turning the 3-position selector switch to "**ENGAGE**" **extends** the restraint. (Spring tension will raise it)

Turning the 3-position selector switch to "**OVERRIDE**" **retracts** the restraint.

Pressing the "**RESET**" button **tilts** the restraint.

This allows the restraint to be moved for servicing or troubleshooting. Ensure that the unit is always put back into normal operation before closing the control panel. To confirm the PLC has been placed in run mode, check to ensure that both the "Power" and "Run" lights on the PLC are illuminated.

### 1. If the restraint will not operate when the 3-position selector switch is turned to "ENGAGE":

- a) Confirm the PLC is in run mode. Both the "Power" and "Run" lights on the PLC must be illuminated.
- b) Confirm that power is reaching the control panel. (E.g. circuit breakers, fuses engaged.)
- c) Re-check all wiring and hydraulic connections.
- d) Ensure proper hydraulic fluid level.
- e) Examine all moving parts for obstructions.
- f) If the problem cannot be solved, consult your authorized Pentalift Representative.

NOTE: If the unit is in combination with a dock leveler, then both overloads will have to be reset.

### 2. If the motor runs but the restraint does not cycle properly:

- a) Confirm the PLC is in run mode. Both the "Power" and "Run" lights on the PLC must be illuminated.
- b) Re-check all hydraulic connections.
- c) Ensure proper hydraulic fluid level.
- d) Check for any obstructions and ensure the restraint can move freely.
- e) Confirm all proximity switch circuits against PLC inputs. Refer to the electrical schematic for a listing of PLC inputs and outputs. The electrical schematic logic may be found inside the control panel.
- f) If the problem cannot be solved, consult your authorized Pentalift representative.

### 3. If the main breaker or overload relay is tripping out.

- a) Check for a short circuit in the wiring.

- b) Check all wire connections and ensure the unit is wired according to the wire diagram supplied with the control panel.
- c) Ensure motor starter thermal overload is set to match pump motor full load amp rating.
- d) If the problem cannot be solved, consult your authorized Pentalift representative.

**4. If the restraint extends or retracts but has a jerking movement:**

- a) Ensure proper hydraulic fluid level.
- b) There may be air present in the hydraulic system. Once the proper hydraulic fluid level has been confirmed, unwanted air can be removed by continuing to cycle the unit.
- c) The operating temperature may be beyond the recommended temperature range of the supplied hydraulic oil. See MAINTENANCE AND LUBRICATION on page 22.
- d) Check for any obstructions and ensure the hook can move freely.
- e) Ensure that all valve wiring is securely fastened.
- f) If the problem cannot be solved, consult your authorized Pentalift representative.

**5. If the pump continues to run when hook is at its**

- a) **fully extended position**
- or
- b) **fully retracted position.**

- a) The extended proximity switch may be loose, improperly adjusted or broken. Adjust the switch. (See ADJUSTMENTS AND TESTING on page 14.) If the switch cannot be adjusted, consult your authorized Pentalift representative.
- b) The retracted proximity switch may be loose, improperly adjusted or broken. Adjust the switch. (See ADJUSTMENTS AND TESTING on page 14.) If the switch cannot be adjusted, consult your authorized Pentalift representative.

**6. If the restraint will not tilt down completely**

- a) Check the hydraulic fluid level.
- b) Check for any obstructions and ensure the hook can move freely.  
NOTE: If the vehicle rear impact guard has moved forward during loading / unloading (truck "creep" has occurred), there may be draw pull force and friction holding the restraint in the engaged position. If the restraint will not release, move the trailer back toward the dock to release the tension on the restraint, allowing it to lower.
- c) Check that the tilt down adjustment bolt is properly located and secure.
- d) Ensure that all pivot points are properly lubricated.
- e) If the problem cannot be solved, consult your authorized Pentalift representative.

**7. If the restraint will not raise completely.**

- a) Check for any obstructions and ensure the hook can move freely.
- b) Ensure the tilt spring tension nut is properly adjusted and the tilt up adjustment bolt is properly located and secure. See ADJUSTMENTS AND TESTING on page 14.
- c) Ensure that all pivot points are properly lubricated.
- d) If the problem cannot be solved, consult your authorized Pentalift representative.

If damaged or worn parts are detected upon inspection, replacement must be undertaken **immediately**. **The vehicle restraint must not be used until replacement is completed.** Parts are readily available from your Pentalift representative.

# REPLACEMENT PARTS

USE ONLY GENUINE PENTALIFT REPLACEMENT PARTS



To ensure proper functioning, durability and safety of the product, only genuine pentlift replacement parts must be used. Altering the product from its original manufactured configuration must not be done. Pentlift equipment Corporation disclaims all liability for failure to comply with this warning. Warranties are specifically disclaimed in the event the purchaser fails to comply with this warning.

To expedite order processing when ordering parts, provide the following information to your Pentlift representative:

1. Model and Serial Number of equipment.
2. Part Number, Description and Quantity.
3. Shipping Instructions.

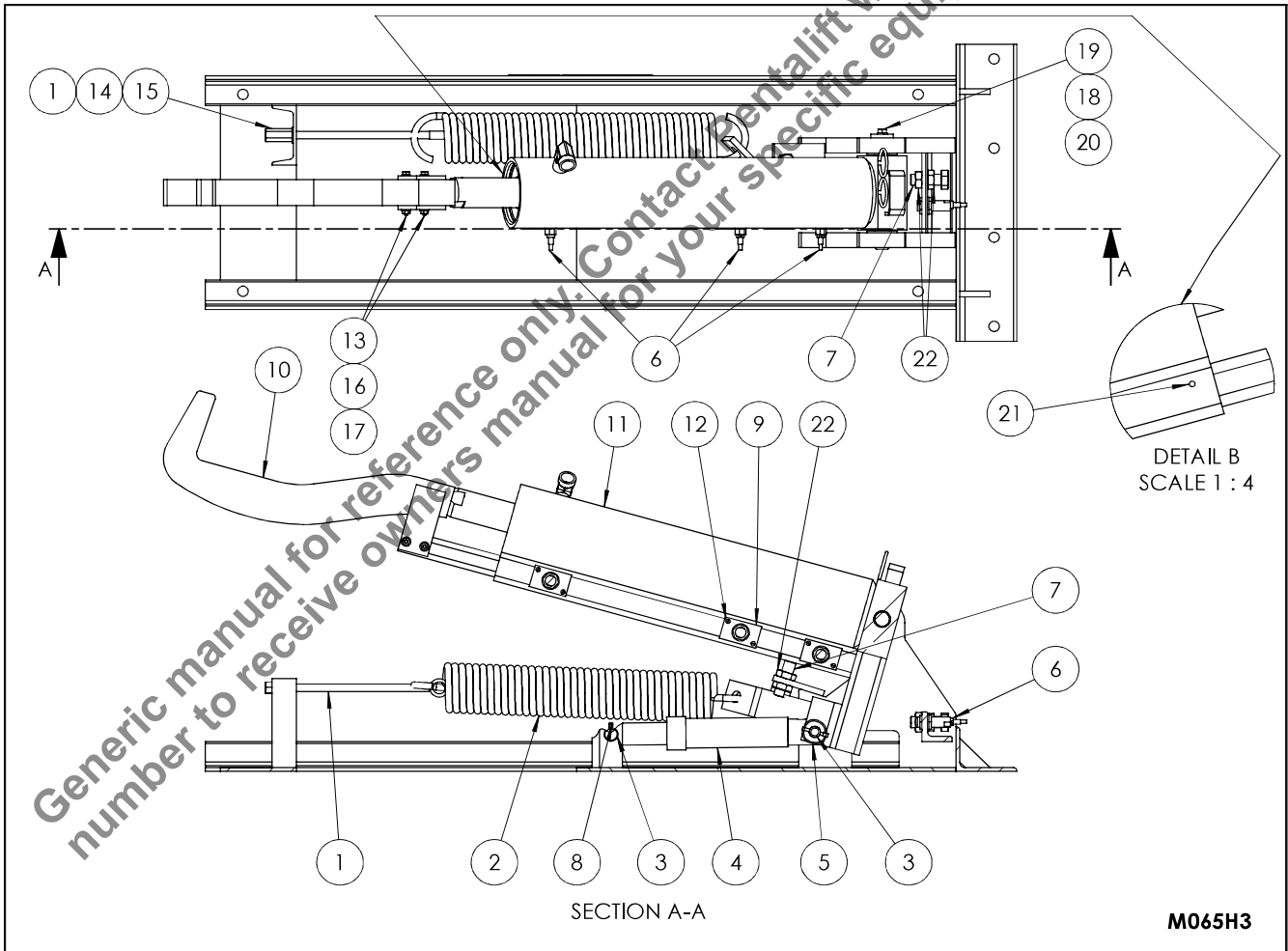

**Figure 20: Mechanical Replacement Parts**

# REPLACEMENT PARTS (Cont.)

USE ONLY GENUINE PENTALIFT REPLACEMENT PARTS

## MECHANICAL REPLACEMENT PARTS LIST

<u>Item #</u>	<u>Part No.</u>	<u>Description</u>
1	3100078	Threaded Rod
2	3020390	Tension Spring
3	3020392	Clevis Pin
4	8020768	Tilt Cylinder Assembly
5	800049	Lynch Pin
6	600687	Proximity Sensor
7	720060	Hex Bolt 3/4-10x2"
8	800001	Split Pin
9	3100021	Proximity Sensor Mounting Plate
10	8100005	Hook Assembly
11	8100042	Hook Cylinder
12	720190	Machine Screw 8-32x1/2"
13	720266	Hex Bolt 1/4-20x2-3/4"
14	740117	Flat Washer 1/2"
15	700080	Hex Coupling Nut 1/2-13x1-1/4"
16	700007	Hex Nut 1/4-20
17	740006	Flat Washer 1/4"
18	740084	Split Washer 3/8"
19	720232	Hex Bolt 3/8-16x3/4"
20	8100010	Pin Assembly
21	960017	Nylon Glide
22	700132	Hex Nut Jam 3/4-10
23	600688	Pressure Switch (at power unit - not shown)

**NOTE:** State Model # and Serial # when ordering replacement parts.

# CONTROL PANEL REPLACEMENT PARTS LIST

USE ONLY GENUINE PENTALIFT REPLACEMENT PARTS

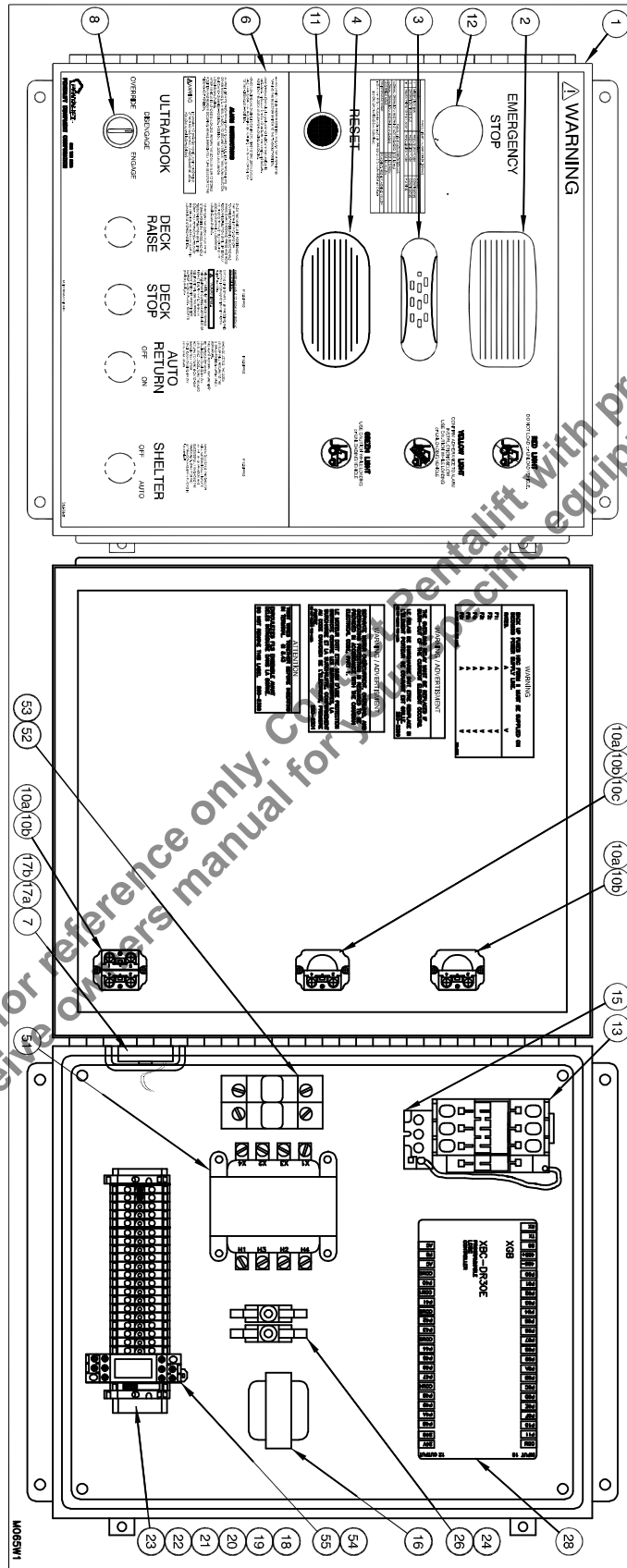

Generic manual for reference only. Call Pentalift with product serial number to receive operators manual for specific equipment.

Figure 21: Control Panel Replacement Parts

<u>ITEM #</u>	<u>PART #</u>	<u>DESCRIPTION</u>	<u>ITEM #</u>	<u>PART #</u>	<u>DESCRIPTION</u>
1	060-0233	Enclosure	22	060-0464	Terminal Stops
2	060-1002	Red Light	23	060-0424	Rail Mounting Bar
3	060-1003	Amber Light	24	060-0380	1/4" Fuse Holder
4	060-1001	Green Light Assembly	25	060-0318	Fuse 5A/250V Time Delay
5			26	060-0316	Fuse 1A/250V Time Delay
6	250-2380	Instruction Label	27	060-0495	Fuse .25A/250V Time Delay
7	054-0351	O-Ring	28	060-1033	PLC
8	060-0713	Key Switch Head	29	060-0205	Fork Terminal Ends
9	060-0433	Switch Head	30	060-0371	Ring Terminal Ends
10a	060-0717	Collar	31	060-0203	Spade Terminal Ends
10b	060-0715	Contact – 1 NO	32	060-0370	Butt Splice
10c	060-0716	Contact – 1 NC	33	060-0550	Spade Terminal Ends
11	060-0437	Push Button Head	34	062-0040	Wire – Black– 16-26 AWG TEW
12	060-0252	Latching Push Button Head	35	062-0045	Wire – White– 16-26 AWG TEW
13	060-0184	Motor Contactor	36	062-0044	Wire – Green– 16-26 AWG TEW
14			37	062-0016	Wire – Red– 16-26 AWG TEW (Opt'l)
15		see chart	38	062-0036	Wire – Black– 14-41 AWG TEW
16	060-0209	18VA Transformer	45/39	072-0236	Screw
17a	060-0097	Alarm	46/40	072-0228	Screw
17b	309-0061	Mounting Bracket	47/41	072-0116	Screw
18	Note	Test Switch Terminal	48/42	074-0019	Washer
19	060-0548	Terminals	49/43	060-0377	Spiral Wrap
20	060-0463	Terminal Ends	50/44	088-0012	Cable Tie
21	060-0466	Terminal Makers	54	060-0551	Relay
			55	060-0554	Relay Base

Components for <b>Three Phase Units</b> (Not Required for Single Phase Units)						
<b>51 Transformer</b>		<b>15 Thermal Overload</b>	<b>52 Fuses</b>		<b>53 Fuse Holder</b>	
060-0121	575/3/60 Voltage	060-1042	060-0024	.5A/600V	060-0381	2 Pole
060-0532	460/3/60 Voltage	060-1042	060-0024	.5A/600V	060-0381	2 Pole
060-0539	230/3/60 Voltage	060-1041	060-0305	1A/600V	060-0381	2 Pole
060-0540	208/3/60 Voltage	060-1041	060-0305	1A/600V	060-0381	2 Pole
060-0539	230/1/60 Voltage	060-1040	060-0305	1A/600V	060-0381	2 Pole
060-0540	208/1/60 Voltage	060-1040	060-0305	1A/600V	060-0381	2 Pole

# TRAFFIC LIGHT REPLACEMENT PARTS

USE ONLY GENUINE PENTALIFT REPLACEMENT PARTS

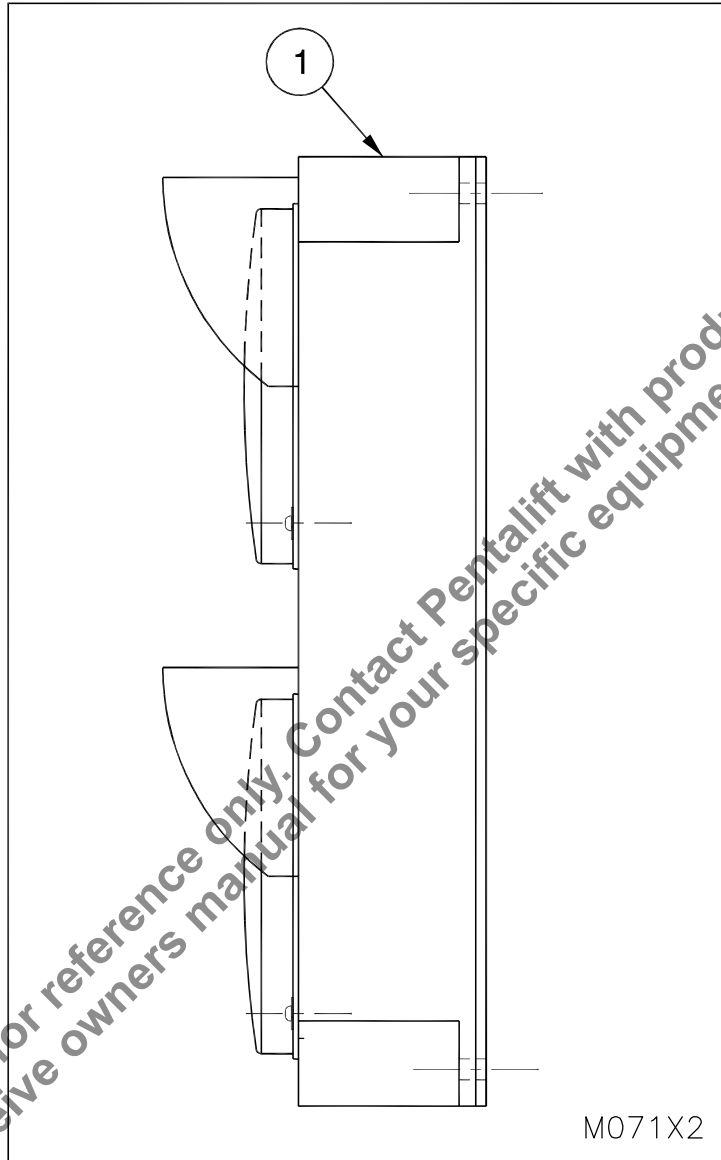

Figure 22: Traffic Light Replacement Parts

<u>Item</u>	<u>Part No.</u>	<u>Description</u>
1	060-0701	Traffic Light Fixture

**NOTE:** State Model # and Serial # when ordering replacement parts.

# REPLACEMENT SIGNS

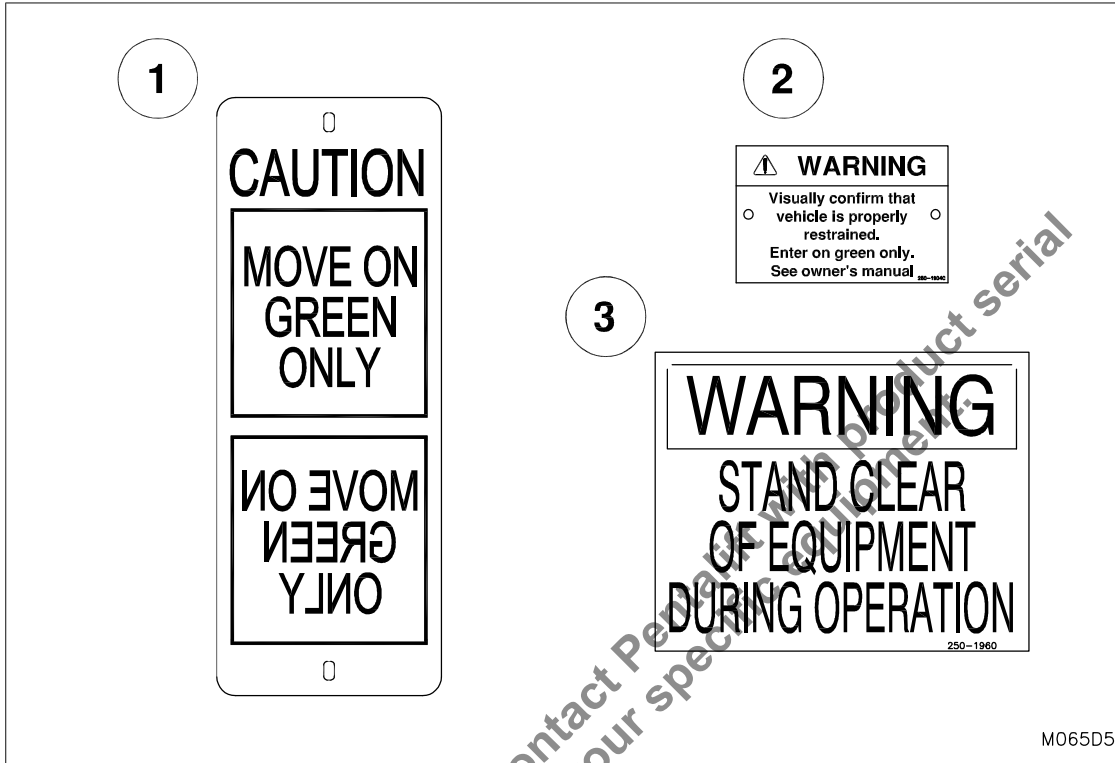

Figure 23: Replacement Signs

<u>Item</u>	<u>Part No.</u>	<u>Qty.</u>	<u>Description</u>
1	250-6991	1	Caution Sign-Move on Green Only (See Figure 7: Mount Outside Light and Signs on page 11)
2	250-1904	1	Interior "Warning" Sign
3	250-1960	1	Exterior "Warning... Stand Clear of Equipment..." (See Figure 7: Mount Outside Light and Signs on page 11)

**NOTE:** State Model # and Serial # when ordering replacement parts.

# LIST OF ILLUSTRATIONS

Figure 1: Precautionary Labels .....	2
Figure 2: Label Locations .....	3
Figure 3: Slings Unit .....	8
Figure 4: Position the Ultrahook .....	8
Figure 5: Mounting the Brush Weather Seal .....	9
Figure 6: Concrete Loading Diagram for Lagged in Models .....	10
Figure 7: Mount Outside Light and Signs .....	11
Figure 8: Power Unit and Junction Box .....	11
Figure 9: Proximity Switch Adjustments .....	15
Figure 10: Adjustment Bolts for Tilt Hard Stops .....	15
Figure 11: Inside Red Light .....	19
Figure 12: Loading Dock Vacant .....	19
Figure 13: Inside Green Light .....	20
Figure 14: Trailer in Position and Rear Impact Guard Secured .....	20
Figure 15: Inside Red Light Flashes and Alarm Sounds .....	21
Figure 16: Rear Impact Guard Not Secure .....	21
Figure 17: Inside Yellow Light .....	21
Figure 18: Secure Trailer by Other Means (i.e. Wheel Chocks) .....	21
Figure 19: Lubrication Points .....	23
Figure 20: Mechanical Replacement Parts .....	28
Figure 21: Control Panel Replacement Parts .....	30
Figure 22: Traffic Light Replacement Parts .....	32
Figure 23: Replacement Signs .....	33

Generic manual for reference only. Contact Pentlift with product serial number to receive owners manual for your specific equipment.

# PENTALIFT EQUIPMENT CORPORATION WARRANTY

## WARRANTY

**Pentalift Equipment Corporation** expressly warrants that any product manufactured by **Pentalift Equipment Corporation** will be free from defects in material and workmanship under normal use for a period of one (1) year from the date of shipment of the equipment, provided the original purchaser maintains and operates the product in accordance with proper procedures. In the event the product proves defective in material or workmanship, **Pentalift Equipment Corporation** will at its option:

1. Replace the product or the defective portion thereof without charge to the purchaser; or
2. Alter or repair the product; on site or elsewhere, as **Pentalift Equipment Corporation** may deem advisable, without charge to the purchaser.

The warranty stated in the previous paragraph is that expressed by **PENTALIFT EQUIPMENT CORPORATION AND IS IN LIEU OF ALL GUARANTEES AND WARRANTIES, EXPRESSED OR IMPLIED BY ANYONE OTHER THAN PENTALIFT EQUIPMENT CORPORATION.** This warranty does not cover any failure caused by improper installation, misapplication, overloading, abuse, negligence, or failure to lubricate and adjust or maintain the equipment properly and regularly. Parts requiring replacement due to damage resulting from abuse, improper operations, improper or insufficient lubrication, lack of proper protection or vehicle impact are not covered by this warranty. **Pentalift Equipment Corporation** assumes no responsibility or liability for:

1. Consequential damages of any kind which result from use or misuse of the equipment
2. Damage or failure resulting from the use of unauthorized replacement parts
3. Damage or failure resulting from modification of the equipment
4. Damage resulting from the misuse of the equipment

THERE ARE NO WARRANTIES, EXPRESSED OR IMPLIED, WHICH EXTEND BEYOND THE DESCRIPTION ON THE FACE HEREOF, AND THERE IS NO WARRANTY OF MERCHANTABILITY OR OF FITNESS FOR A PARTICULAR PURPOSE.

**Pentalift Equipment Corporation** warranties extend only to the original product itself. In no event shall **Pentalift Equipment Corporation** be responsible for or liable to anyone, including third parties, for special, indirect, collateral, punitive, incidental or consequential damages, even if **Pentalift Equipment Corporation** has been advised of the possibility of such damages. Such excluded damages include, but are not limited to, loss of good will, loss of profits, loss of use, interruption of business or other similar indirect financial loss.

**Pentalift Equipment Corporation** DISCLAIMS all liability arising out of the workmanship, methods and materials used by the installer.

**Pentalift Equipment Corporation** DISCLAIMS all liability for premature product wear, product failure, property damage or bodily injury arising from improper installation and application.

**Pentalift Equipment Corporation** will not accept any warranty for which the original purchaser does not notify **Pentalift Equipment Corporation's** Warranty Department of the defect within ninety (90) days after the product defect is discovered. A fully completed Product Registration Card is required prior to the review or processing of any warranty requests or claims.

WARRANTIES, whether expressed or implied, relating to workmanship and materials used in connection with the installation of **Pentalift Equipment Corporation** products are specifically DISCLAIMED.

WR001R03

### PENTALIFT EQUIPMENT CORPORATION

P.O. Box 1510, Buffalo, NY 14240-1510, U.S.A 21 Nicholas Beaver Rd. Puslinch, ON N0B 2J0, Canada  
(519) 763-3625 Fax (519) 763-2894  
[www.pentalift.com](http://www.pentalift.com)