



## PENTALIFT EQUIPMENT CORPORATION

# HYDRAULIC DOCK LEVELER OWNERS MANUAL

MODEL NUMBER : \_\_\_\_\_ SERIAL NUMBER : \_\_\_\_\_

CAPACITY : \_\_\_\_\_

Individual Model Number(s) and Serial Number(s) must be filled out by the user for future reference.

### **This manual is an important document.**

It shall be kept with the machine or located where readily available to operators and maintenance personnel for reference purposes. Do not install, operate or service this product unless you have read and fully understand the entire contents of this manual. Failure to do so may result in property damage, bodily injury or death. Keep this manual in a safe place for future reference.

**NOTE:** A very high level of field issues with this type of equipment can be directly attributed to improper or incomplete installation. The installation instructions and information provided for this equipment is thorough. A step by step sequence for installation is provided. All steps must be followed and completed to provide a complete installation. Incomplete or improper installations can lead to equipment malfunction and / or damage, create safety issues and void warranties. Please follow all installation and set ups steps as indicated in the installation instructions and owner's manual. If you are unclear or uncertain regarding any of the steps contact your Pentalift representative for clarification. A copy of the completed steps listing with the sign off and photos of the installation as indicated at the conclusion of the installation instructions will be required prior to any Pentalift factory trouble shooting assistance.

**Pentalift Equipment Corporation  
21 Nicholas Beaver Rd  
Puslinch, ON N0B 2J0  
Phone: 519-763-3625  
Fax: 519-763-2894  
Parts Phone: 519-763-3625 Extension 625  
Ask for Parts Department**

**Pentalift Equipment Corporation provides an owners manual when equipment is shipped. Additional manuals are available at \$25.00 each.**

**IMPORTANT:** The owners manuals that are provided on Pentalift Equipment Corporations website are generic in nature. They are provided for general information only. For all purposes, only the owners manual that is specific to the equipment should be referenced and relied on. In order to receive the specific owners manual for specific Pentalift equipment, please contact your Pentalift representative and supply the specific serial number(s) for the equipment the manual is required for. Do not rely on the information in the generic owners manuals provided through the website as it may not be appropriate for your specific Pentalift equipment.

*Generic manual for reference only. Contact Pentalift with product serial number to receive owners manual for your specific equipment.*

# PRODUCT REGISTRATION

	<p><b>PRODUCT REGISTRATION CARD</b></p> <p>To validate warranty and to advise of product updates please complete the following information and return to  <b>Pentalift Equipment Corporation</b></p> <p>To validate warranty on-line go to: <a href="http://www.pentalift.com">www.pentalift.com</a></p>	
<b>END USER INFORMATION</b>		
*Company Name:		
Contact *First Name:	*Last Name:	Title:
*Mailing Address:		
*City:	*State/Prov.	*Zip/Postal Code:
*Phone: ( ) -	Fax: ( ) -	Email:
Check Products Purchased:	<input type="checkbox"/> Levelers, <input type="checkbox"/> Vehicle Restraints, <input type="checkbox"/> Seals/Shelters, <input type="checkbox"/> Elevating Docks, <input type="checkbox"/> Lift Tables	
*Serial Number(s):	Invoice # (if available):	
Dealer Name:	Sales Rep.:	
Manual Verification	*Manual Number:	

Please return to:

Pentalift Equipment Corporation  
 P.O. Box 1510,  
 Buffalo, NY 14240-1510

or

Pentalift Equipment Corporation  
 21 Nicholas Beaver Rd  
 Puslinch, Ontario  
 N0B 2J0

Attention: Service Department

Or Fax to (519) 763-2894

# SAFETY INFORMATION AND WARNINGS



**READ THESE SAFETY PRACTICES BEFORE INSTALLING, OPERATING OR SERVICING THE DOCK LEVELER. FAILURE TO FOLLOW THESE SAFETY PRACTICES MAY RESULT IN PROPERTY DAMAGE, BODILY INJURY OR DEATH.**

THE OPERATION OF THIS EQUIPMENT IS SUBJECT TO CERTAIN HAZARDS THAT CAN BE PROTECTED AGAINST ONLY BY THE EXERCISE OF CARE AND COMMON SENSE AND NOT BY MECHANICAL MEANS. IT IS, THEREFORE, ESSENTIAL TO HAVE COMPETENT, QUALIFIED OPERATORS TRAINED IN THE SAFE OPERATION AND CARE OF THIS TYPE OF EQUIPMENT. ALL PERSONNEL MUST COMPLETELY UNDERSTAND THIS SAFETY INFORMATION BEFORE WORKING ON OR NEAR THIS EQUIPMENT.



**DANGER** indicates an imminently hazardous situation which, if not avoided, will result in death or serious injury.



**WARNING** indicates a potentially hazardous situation which, if not avoided, could result in death or serious injury.



**CAUTION**, used with the safety alert symbol, indicates a potentially hazardous situation which, if not avoided, could result in minor or moderate injury.

## NOTICE

**NOTICE** is used to address practices not related to personal injury.



**Before doing any installation, maintenance, inspection or trouble shooting, barricade all areas from traffic around the work area inside (and outside if applicable) for safety and post appropriate warning signs.**



**Arc flash and shock hazard PPE (personal protection equipment) required. De-energize equipment before working on or inside. Do not open cover without appropriate PPE. Refer to NFPA 70E for PPE requirements. This panel may contain more than one power source. Hazardous voltage will cause severe injury or death.**



**Before doing any electrical work, be certain that the power is disconnected with a fused disconnect, properly tagged and locked out. Fused disconnect and lockout device (supplied and installed by others) must meet with all applicable codes and regulation. All electrical work must be performed by a qualified electrician in accordance with all applicable codes and regulations.**



**NEVER GO BENEATH THE DOCK LEVELER FOR ANY REASON UNLESS THE DECK AND LIP ARE PROPERLY SUPPORTED (SEE "SUPPORTING THE LEVELER FOR MAINTENANCE" on page 50) AND THE POWER IS DISCONNECTED WITH A FUSED DISCONNECT, PROPERLY TAGGED AND LOCKED OUT. IT IS THE RESPONSIBILITY OF THE OWNER TO ENSURE THAT NO LOAD OR TRAFFIC IS PLACED ON THE DECK WHILE THE MAINTENANCE STAND IS ENGAGED. THE CONSTRUCTION OF THE MAINTENANCE STAND IS INTENDED TO SUPPORT THE WEIGHT OF THE UNLOADED DOCK LEVELER ONLY.**



**NEVER USE THE "DECK STOP" BUTTON (if equipped) AS A MEANS OF HOLDING THE DOCK UP WHILE PERFORMING MAINTENANCE OR INSPECTION.**



**TO AVOID POSSIBLE PERSONNEL INJURY AS WELL AS, TO AVOID DAMAGE TO THE DOCK LEVELER AND/OR THE PRODUCT, DO NOT DRAG OR SLIDE ANYTHING ACROSS THE SURFACE OF THE DOCK LEVELER. ALWAYS ENSURE THE FORKLIFT FORKS ARE RAISED TO CLEAR THE DOCK LEVELER SURFACE AND THE DOCK LEVELER COMPONENTS.**



**NEVER WALK ON THE DOCK LEVELER LIP UNLESS IT IS FULLY EXTENDED AND SUPPORTED BY THE TRUCK BED.**

## **⚠ DANGER**

**DOCK LEVELER CAPACITY: THE RATED CAPACITY OF THE DOCK LEVELER AS STATED ON THE SERIAL NUMBER PLATE IS A STATIC RATING. NUMEROUS DYNAMIC LOADING FACTORS RESULT IN THE GROSS LOAD CAPACITY (ROLLOVER CAPACITY) BEING SIGNIFICANTLY LESS THAN THE RATED STATIC CAPACITY OF THE DOCK LEVELER. FACTORS WHICH AFFECT THE ROLL OVER CAPACITY ARE: WEIGHT OF THE LOAD; WEIGHT OF THE FORK TRUCK; SPEED OF THE FORK TRUCK AS IT ROLLS OVER THE DOCK LEVELER; INCLINE OR DECLINE SLOPE OF THE DOCK LEVELER DECK AND LIP WHEN IN USE; FREQUENCY OF USE AND DESIRED LIFE OF THE DOCK LEVELER. PRIOR TO USING THE DOCK LEVELER, OR IF THE APPLICATION CONDITIONS FOR THE DOCK LEVELER CHANGE IN ANY RESPECT, CONTACT YOUR AUTHORIZED PENTALIFT REPRESENTATIVE TO CONFIRM THE SPECIFIC DOCK LEVELER'S SUITABILITY FOR THE APPLICATION.**

**Note On Capacity:** The dock leveler capacity indicated on the serial plate must be divided with a factor to accommodate dynamic loading factors. For more information see Pentalift document - Dock Leveler Capacity – Understanding Loading Dock Capacity at <http://www.pentalift.com/dock-leveler-capacity.php>

## **⚠ DANGER**

**ALWAYS ASSURE NO ONE IS WITHIN 6 FEET OF THE FRONT (LIP END) OF THE DOCK LEVELER PRIOR TO ACTIVATION. STAY CLEAR OF DOCK LEVELER WHEN IT IS MOVING.**

## **⚠ WARNING**

**It is the responsibility of others to ensure the proper mounting of any wall mounted equipment such as remote power units, control panels and light packages and to ensure that the mounting surface is capable of fully supporting the loads generated by the equipment.**

## **NOTICE**

**OVERHEAD DOOR INTERLOCKS ARE FOR PROCEDURAL REASONS AND DO NOT PROVIDE ANY ADDITIONAL SAFETY FEATURES BEYOND THOSE THAT ARE STANDARD FOR THIS EQUIPMENT.**

- 1. HYDRAULIC FALLSAFE:** The basic purpose of the fallsafe feature is to arrest the deck's downward movement in the event of premature truck departure creating a loss of support for the dock leveler lip. If a fallsafe situation should occur, the dock leveler must be inspected by an authorized Pentalift representative before operation continues. The owner must receive written authorization from Pentalift Equipment Corporation through the authorized Pentalift representative before continuing to use the dock leveler.
2. When not in use, the deck must be in the stored (cross traffic) position, with the lip inside the front angle. (See "Figure 57: Deck in (Cross Traffic) Stored Position" on page 48)
3. Before loading/unloading the truck, assure the trailer is in position firmly against both of the dock bumpers and **ENGAGE A VEHICLE RESTRAINT or CHOCK THE TRUCK WHEELS** to eliminate the possibility of the truck rolling or inching forward.
4. Return the dock leveler to the stored position before allowing the truck to depart.
5. Be certain no equipment, material or personnel are on the dock leveler before allowing truck to depart.
6. Regular inspection and maintenance must be performed to keep the equipment in proper operating condition in accordance with the detailed instructions in this manual.
7. Anyone using or in the vicinity of this equipment must wear protective footwear with steel toes.
8. The deck surface must be kept clean and free from oil, debris, etc. Keep debris, etc. from underneath the unit.
9. Never use a fork truck to lower the deck from its raised position.
10. Do not operate, use, maintain or install this equipment if you are impaired in any manner.
11. Never stand between the dock and a truck.
12. Stay clear of operating path at all times.

13. Ensure that the equipment is not used by anyone if you believe that any part of it might be in disrepair (e.g. loose wires, leaking hoses, bent structural members, broken welds, etc.). See “INSTALLATION, INSPECTION, MAINTENANCE AND LUBRICATION” on page 56.
14. If you have any questions contact your immediate supervisor or your authorized Pentalift representative for assistance.

**Generic manual for reference only. Contact Pentalift with product serial number to receive owners manual for your specific equipment.**

# OWNER RESPONSIBILITY

The Owner's Responsibilities include the following:

1. The owner shall recognize the inherent danger of the interface between dock and transport vehicle. The Owner shall, therefore, train and instruct operators in the safe use of dock leveling devices.
2. When a transport vehicle is positioned as closely as practicable to a dock leveling device, there shall be at least 4" (100 mm) of overlap between the front edge of the lip and the edge of the floor or sill of the transport vehicle.
3. Nameplates, cautions, instructions and posted warnings shall not be obscured from the view of operating or maintenance personnel for whom such warnings are intended.
4. Manufacturer's recommended periodic maintenance and inspection procedures in effect at date of shipment shall be followed, and written records of performance of these procedures shall be kept.
5. Dock leveling devices that are structurally damaged or have experienced a sudden loss of support while under load, such as might occur when a transport vehicle is pulled out from under the dock leveling device, shall be removed from service, inspected by **Pentalift Equipment Corporation's** authorized representative and repaired as needed before being placed back in service. The owner shall receive written authorization from **Pentalift Equipment Corporation** through the authorized Pentalift representative that they can continue to use the dock leveler.
6. **Pentalift Equipment Corporation** shall supply replacement nameplates, caution or instruction labels and operating and maintenance manuals upon request of the owner. The owner shall see that all nameplates and caution and instruction markings or labels are in place and legible and that the appropriate operating and maintenance manuals are provided to users.
7. Modifications or alterations of dock leveling devices shall be made only with written permission of **Pentalift Equipment Corporation**. Alteration permission must be signed by both the Pentalift Post Sale Customer Service Manager and the President to be valid.
8. When industrial trucks are driven on and off transport vehicles during the loading and unloading operation, the brakes on the transport vehicle shall be applied and wheel chocks or positive restraints that provide the equivalent protection of wheel chocks engaged.  
**NOTE:** It is recognized that these devices are intended to secure a transport vehicle to a loading dock by mechanical means. However, no standards currently exist for the strength, construction or attachment of the underride guard on a transport vehicle. It is therefore recommended that users of such positive restraint devices review:
  - The means of attachment to the transport vehicle
  - The strength of the overall connection
  - The proper coordination of the actuation of devices with any signalling system used
  - The need to use wheel chocks
9. In selecting dock leveling devices, it is important to consider not only present requirements, but also future plans or adverse environments.



Unless specifically agreed to in writing by Pentalift Equipment Corporation at the time the equipment is ordered and prior to the equipment's manufacture, this equipment is sold as a complete package. It is not to be altered, changed or added to in any way or form, in its configuration and function, without the written permission of Pentalift Equipment Corporation.

If requested by a customer, Pentalift Equipment Corporation is not supplying all or some of the power unit and / or control components for the equipment's application. The power unit and controls constitute important safety and functional aspects of the equipment. It is the customer's responsibility to address the operational and safety issues associated with providing the required controls and power units to satisfy the operational and safety requirements of the equipment.

The customer's decision to supply all or some of these components indicates that the customer is taking full responsibility for any and all possible operational, safety and liability issues associated to the product and its configuration. The customer also agrees to absolve Pentalift Equipment Corporation from any and all possible operation, safety and liability issues.

# TABLE OF CONTENTS

PRODUCT REGISTRATION .....	I
SAFETY INFORMATION AND WARNINGS .....	II
OWNER RESPONSIBILITY .....	V
TABLE OF CONTENTS .....	1
SAFETY LABELING .....	3
INSTALLATION INSTRUCTIONS .....	7
PREPARATION PRIOR TO INSTALLATION .....	7
SELF-CONTAINED POWER UNIT .....	9
REMOTE POWER UNIT .....	10
LEVELING INSTRUCTIONS (NOT FOR ROLL-OFF STOP MODELS) .....	12
LEVELING INSTRUCTIONS (FOR ROLL-OFF STOP MODELS) .....	13
INSTALLATION USING SHIM KIT .....	15
SELF CONTAINED POWER UNIT .....	15
REMOTE POWER UNIT .....	20
INSTALLATION USING FILLER PLATE .....	22
INSTALLATION INSTRUCTIONS FOR 3-INCH FILLER PLATE .....	22
INSTALLATION INSTRUCTIONS FOR 4-INCH FILLER PLATE .....	23
FILLER PLATE INSTALLATION INSTRUCTIONS (WITH TWO TUBES & TWO SUPPORT BARS) .....	24
FILLER PLATE INSTALLATION INSTRUCTIONS (WITH TWO TUBES & FOUR SUPPORT BARS) .....	25
WELDING REFERENCE INFORMATION .....	26
INSTALLATION PICTURES .....	27
ELECTRICAL REFERENCE CHART .....	27
INSTALLATION INSTRUCTIONS .....	31
POUR-IN DOCK LEVELERS .....	31
PREPARATION PRIOR TO INSTALLATION .....	31
hydraulic dock leveler with self contained power unit: .....	36
ELECTRICAL REFERENCE CHART .....	39
INSTALLATION PICTURES .....	40
Bumper Installation Guide lines .....	41
Locating Dock Bumpers during installation: .....	41
Installation methods I.E. Lagging and or welding: .....	41
OPTIONAL AUTO RETURN .....	44
Auto Return Activation .....	44
Auto Return Adjustment .....	44
Fallsafe Feature .....	44
BREAK-IN AND PERFORMANCE CHECK .....	45
OPERATING INSTRUCTIONS .....	46
Standard Models: .....	47
For Models Equipped with Auto Return: .....	48
For Models Equipped with Deck Stop/ Independent Lip: .....	48
Below Level End Loading .....	49
Standard Models .....	49
Models with Auto Return .....	49
Models with Deck Stop/Independent Lip Control .....	49

END LOADING/UNLOADING .....49

SUPPORTING THE LEVELER FOR MAINTENANCE.....50

ADJUSTABLE LIP STOP .....53

TROUBLE SHOOTING GUIDE .....54

INSTALLATION, INSPECTION, MAINTENANCE AND LUBRICATION.....56

REPLACEMENT PARTS .....59

    TABLES OF ELECTRICAL PART NUMBERS .....64

LIST OF ILLUSTRATIONS.....65

PENTALIFT EQUIPMENT CORPORATION WARRANTY.....67

*Generic manual for reference only. Contact Pentalift with product serial number to receive owners manual for your specific equipment.*

# SAFETY LABELING

1

LIFT 1 DOCK ONLY (WITH NO LOAD ON IT)  
**FORKS HERE**



250-1127  
QTY. - 2 PER UNIT

2

**CAUTION**  
THIS EQUIPMENT HAS BEEN BOLTED CLOSED FOR SHIPPING.  
REMOVE ALL SHIPPING BOLTS BEFORE OPERATING.

250-1141  
QTY. - 1 PER UNIT

3

INSPECTION  
\_\_\_\_\_  
DATE                      INSPECTED BY

250-1148  
QTY. - 1 PER UNIT

4

**IMPORTANT**  
READ THE INSTALLATION INSTRUCTIONS AND OWNERS MANUAL IN THEIR ENTIRETY BEFORE INSTALLING AND/OR USING THIS EQUIPMENT.

250-2058  
QTY. - 1 PER UNIT

5

**PENTALIFT**

250-1143  
QTY. - 1 PER UNIT

6

**WARNING** READ AND UNDERSTAND THE ENTIRE OWNERS MANUAL PRIOR TO INSTALLING, OPERATING, SERVICING OR MODIFYING THIS EQUIPMENT.  
DO NOT REMOVE THIS LABEL.  
MODEL: \_\_\_\_\_  
SERIAL NO.: \_\_\_\_\_ CAPACITY: \_\_\_\_\_  
NOTE: THE PLATED DOCK LEVELER CAPACITIES, AS INDICATED ON THE SERIAL NUMBER PLATE ARE SUBJECT TO DYNAMIC CAPACITY FACTORS. REFER TO THE PENTALIFT DOCUMENT "UNDERSTANDING LOADING DOCK CAPACITY". THIS DOCUMENT IS AVAILABLE FROM YOUR PENTALIFT REPRESENTATIVE OR AT: WWW.PENTALIFT.COM/DOCK-LEVELER-CAPACITY.HTML. CONTACT YOUR PENTALIFT REPRESENTATIVE WITH ANY QUESTIONS OR CLARIFICATIONS RELATED TO THE PLATED CAPACITY AND THE DYNAMIC CAPACITY FACTOR THAT APPLIES FOR A SPECIFIC APPLICATION.  
MADE IN CHINA      1-(919)-783-3625      WWW.PENTALIFT.COM      250-1817

250-1817  
QTY. - 1 PER UNIT

8

**WARNING**  
TO AVOID PERSONAL INJURY READ OWNERS MANUAL BEFORE OPERATING

**DANGER** 1. DO NOT WALK ON UP TO LOWER DOCK LEVELER  
**PENTALIFT**  
STAND CLEAR  
**DANGER** 2. DO NOT WALK ON UP TO LOWER DOCK LEVELER

TO AVOID PERSONAL INJURY READ OWNERS MANUAL BEFORE OPERATING  
**WARNING**

250-1882  
QTY. 2 PER UNIT

9

 <p><b>DANGER</b></p> <p>Unsupported dock leveler ramps can lower unexpectedly.</p> <p>Before allowing vehicle to leave the dock, always:</p> <ul style="list-style-type: none"> <li>* Ensure that no equipment, material or people are on the dock leveler.</li> <li>* Return the dock leveler to its stored position at dock level.</li> </ul> <p>Failure to follow posted instructions will result in death or serious injury.</p> <p><b>DO NOT REMOVE THIS LABEL.</b></p>	<p><b>SAFETY INFORMATION</b></p> <p><b>OPERATION</b></p> <ol style="list-style-type: none"> <li>Read and follow all instructions and warnings in the owner's manual</li> <li>Use of dock leveler restricted to properly trained operators.</li> <li>Always check trailer wheels or engage trailer restraint before operating dock leveler or beginning to load or unload.</li> <li>Never use hands or equipment to move ramp or lip.</li> <li>Before actuating dock leveler:                     <ul style="list-style-type: none"> <li>- Ensure trailer is locked in against bumpers.</li> <li>- Remove any and loads if required</li> <li>- Check trailer alignment to avoid lip interference. If lip does not lower to trailer bed, reposition vehicle.</li> </ul> </li> <li>Ensure truck bed supports extended lip or leveler frame supports the ramp before driving on ramp.</li> </ol>	
	<p>7. Stay clear of hinges and front and sides of moving dock leveler.</p> <p>8. Never use damaged or malfunctioning dock leveler. Report problems immediately to supervisor.</p> <p><b>MAINTENANCE/SERVICE</b></p> <ol style="list-style-type: none"> <li>Read and follow all instructions, warnings, and maintenance schedules in the owner's manual.</li> <li>Maintenance/Service of dock leveler restricted to properly trained personnel.</li> <li>Place barriers on driveway and dock floor to show service work is being performed</li> <li>DO NOT ENTER PIT unless dock leveler is securely supported by maintenance stand.</li> <li>If electrically powered, turn off and use OSHA lockout/tagout procedures.</li> </ol> <p>Call 919-783-3625 for replacement placards, warning labels, or owner's manual. 250-2320</p>	

250-2320  
QTY. 2 PER UNIT

M056D3-1A

Figure 1: Safety Labels and Decals



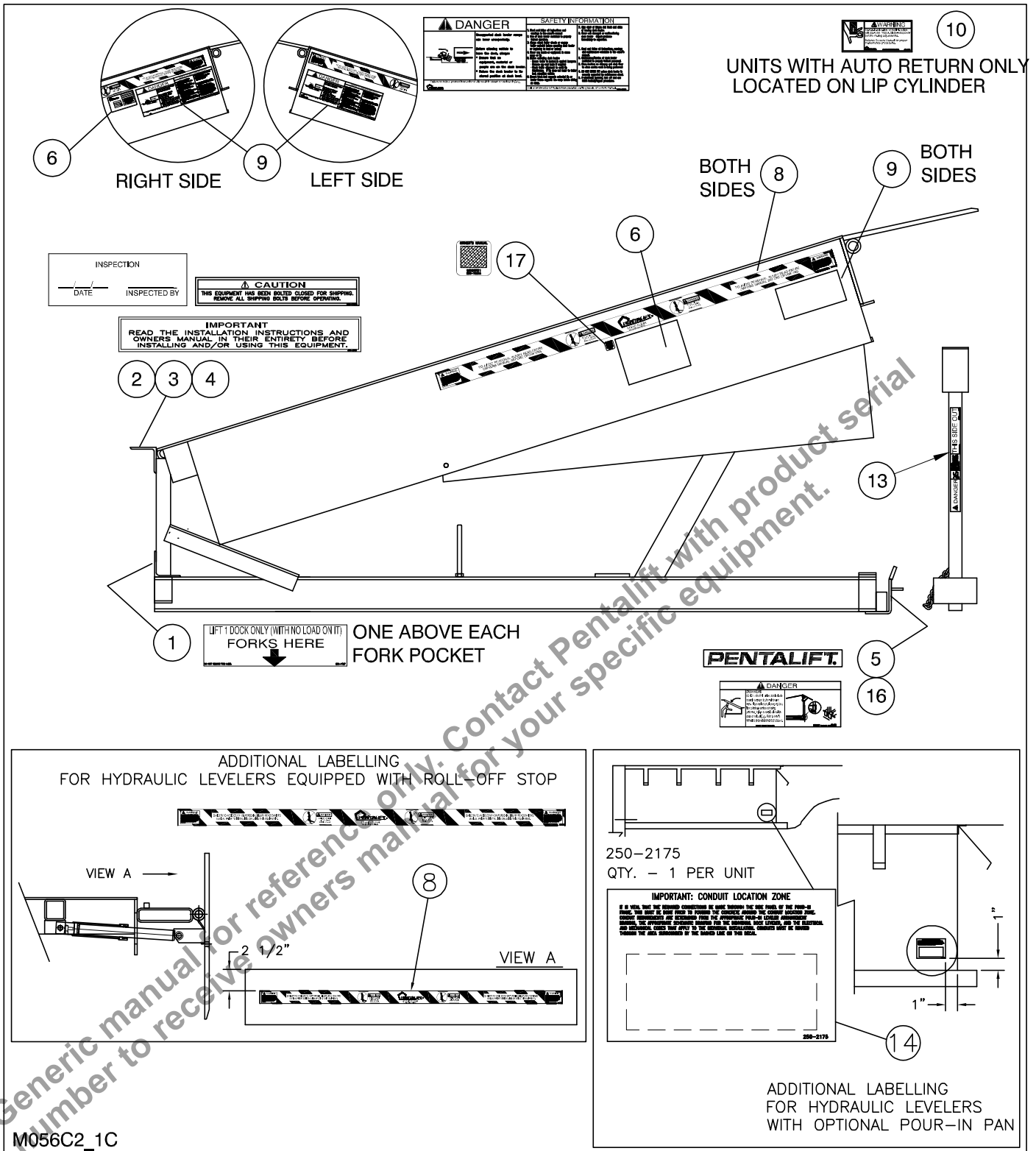
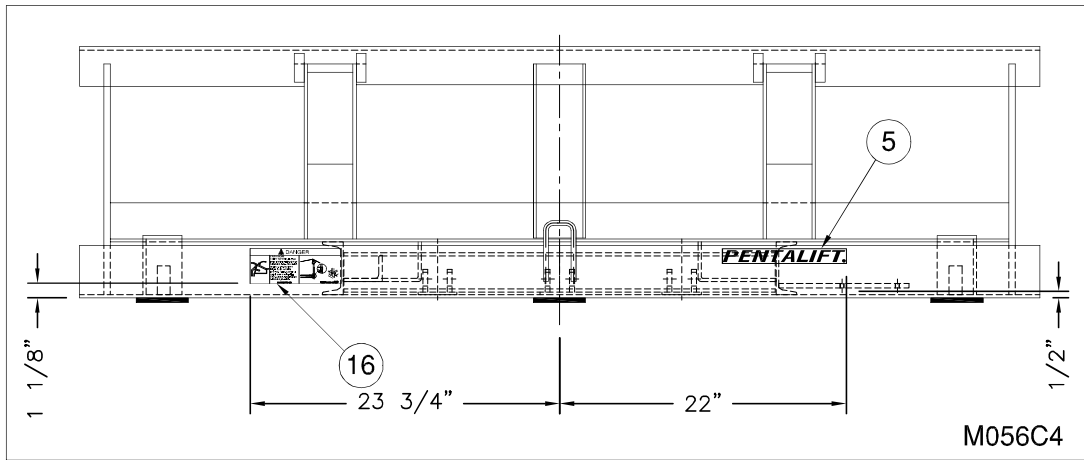

Figure 3: Safety Label and Decal Location



**Figure 3a: Safety Label and Decal Location - Front Angle**

Be sure that all labeling is in place and intact when the unit is received. If any of the safety labels or decals are missing or illegible, contact your Pentalift representative for immediate replacement.

**NOTE:** In some instances, product configuration and / or product options may dictate that the product labels will not be placed as indicated on the drawing (Figure 2: Safety Labels and Decals Continued on page 4). Different label locations will be selected at the factory, when required, to avoid an impaired view of the labels. Note the label locations as supplied on the product, when it is received to accommodate future label replacement requirements.

**NOTE:** It is the owner's responsibility to assure that all safety labeling remains legible and in its original position throughout the life of the product. It is also the owner's responsibility to assure that all labels are and will continue to be readily visible to the operators and people working with and around the equipment. If the visibility of any label is compromised for any reason then; either 1) Rectify the situation to allow the label to be readily visible 2) Order replacement label(s) from Pentalift for installation in a location that does facilitate complete visibility. If any of the safety labels or decals are missing or illegible, contact your Pentalift representative for immediate replacement. Inspection shall be done during regular maintenance and lubrication (MAINTENANCE AND LUBRICATION on page 56).

To re-order labels and decals, use the following part numbers:

ITEM NO.	PART NO.	QTY/UNIT	DESCRIPTION
1	250-1127	2	"FORKS HERE"
2	250-1141	1	"CAUTION..."
3	250-1148	1	"INSPECTION"
4	250-2058	1	"IMPORTANT..."
5	250-1143	1	"PENTALIFT"
6	250-1817	1	Specification Plate
8	250-1882	2 (1)	Safety Stripe (QTY:3 REQ'D for Roll-off Unit)
9	250-2320	2	"DANGER Unsupported dock..."
10	250-2514	1	"DANGER Manual Activation..."
13	250-2467	1	"DANGER Crush Hazard..."
14	250-2175	1	"IMPORTANT CONDUIT LOCATION ZONE" Note: For units with optional Pour-In Pan.
15	250-2519	1	"OPERATING INSTRUCTIONS"
16	250-2496	1	"DANGER Do not work under dock..."
17	250-7024	1	"DECAL;BARCODE;HD" (next to serial number plate)
	250-7024	1	"DECAL;BARCODE;HD" (affixed to control panel)
	250-7024	1	"DECAL;BARCODE;HD" (affixed to placard)

**NOTE:** State Model # and Serial # when ordering replacement parts.

# INSTALLATION INSTRUCTIONS



Do not install, operate or service this product unless you have read and fully understand the entire contents of this manual. Failure to do so may result in property damage, bodily injury or death.

**NOTE:** A very high level of field issues with this type of equipment can be directly attributed to improper or incomplete installation. The installation instructions and information provided for this equipment is thorough. A step by step sequence for installation is provided. All steps must be followed and completed to provide a complete installation. Incomplete or improper installations can lead to equipment malfunction and / or damage, create safety issues and void warranties. Please follow all installation and set ups steps as indicated in the installation instructions and owner's manual. If you are unclear or uncertain regarding any of the steps contact your Pentalift representative for clarification. A copy of the completed steps listing with the sign off and photos of the installation as indicated at the conclusion of the installation instructions will be required prior to any Pentalift factory trouble shooting assistance.

---

## IMPORTANT

### PREPARATION PRIOR TO INSTALLATION

---

**NOTE:** Perform installation instructions in the same sequence as they are listed below. To accommodate a complete installation there is a blank space provided beside each numbered step in the installation instructions. Please check off the steps sequentially as they are completed. This will assist in confirming a complete installation.



Before doing any installation, maintenance, inspection or trouble shooting, barricade all areas from traffic around the work area inside (and outside if applicable) for safety and post appropriate warning signs.



Arc flash and shock hazard PPE (personal protection equipment) required. De-energize equipment before working on or inside. Do not open cover without appropriate PPE. Refer to NFPA 70E for PPE requirements. This panel may contain more than one power source. Hazardous voltage will cause severe injury or death.



Before doing any electrical work, be certain that the power is disconnected with a fused disconnect, properly tagged and locked out. Fused disconnect and lockout device (supplied and installed by others) must meet with all applicable codes and regulations. All electrical work must be performed by a qualified electrician in accordance with all applicable codes and regulations.



NEVER GO BENEATH THE DOCK LEVELER FOR ANY REASON UNLESS THE DECK AND LIP ARE PROPERLY SUPPORTED (SEE "SUPPORTING THE LEVELER FOR MAINTENANCE" on page 50) AND THE POWER IS DISCONNECTED WITH A FUSED DISCONNECT, PROPERLY TAGGED AND LOCKED OUT. IT IS THE RESPONSIBILITY OF THE OWNER TO ENSURE THAT NO LOAD OR TRAFFIC IS PLACED ON THE DECK WHILE THE MAINTENANCE STAND IS ENGAGED. THE CONSTRUCTION OF THE MAINTENANCE STAND IS INTENDED TO SUPPORT THE WEIGHT OF THE UNLOADED DOCK LEVELER ONLY.



BE SURE ALL HYDRAULIC FITTINGS ARE RATED FOR HYDRAULIC SYSTEMS THAT MAY PEAK OUT AT 4000PSI. HARDWARE STORE ITEMS CAN BURST AT 150PSI. ONLY BUY REPLACEMENT PARTS FROM PENTALIFT.



It is the responsibility of others to ensure the proper mounting of any wall mounted equipment such as remote power units, control panels and light packages and to ensure that the mounting surface is capable of fully supporting the loads generated by the equipment.

1. \_\_\_ Assure pit conforms to appropriate Pentlift pit drawing.
2. \_\_\_ Confirm pit curb angle is properly installed and meets the force requirements as shown in Figure 24, page 30.
3. \_\_\_ Clean pit of all debris.

4. — **⚠ DANGER** MAKE SURE LIFTING AND SLINGING DEVICES ARE OF SUFFICIENT CAPACITY, USED IN THE CORRECT MANNER AND ARE IN GOOD WORKING ORDER. ALL LIFTING, POSITIONING AND INSTALLATION, AS WELL AS THE BREAK-IN AND PERFORMANCE CHECK MUST BE DONE BY QUALIFIED PERSONNEL TRAINED AND EXPERIENCED IN NECESSARY SAFETY PROCEDURES.

5. — **⚠ DANGER** INADEQUATE LIFTING EQUIPMENT OR PRACTICES CAN CAUSE A LIFTED LOAD TO FALL UNEXPECTEDLY. MAKE SURE THAT EYE BOLTS AND LIFTING CHAIN OR OTHER LIFTING DEVICES ARE IN GOOD CONDITION AND HAVE A RATED CAPACITY OF AT LEAST 3500 LBS FOR THE LIFTING ANGLE USED. CONFIRM THE SHIPPING WEIGHT OF THE DOCK LEVELER. IF IT IS GREATER THAN 3500 LBS THEN INCREASE THE RATED CAPACITY OF THE LIFTING DEVICE(S) TO ACCOMMODATE THE SHIPPING WEIGHT OF THE DOCK LEVELER WHEN IT IS BEING LIFTED OR PLACED INTO THE PIT. STAND CLEAR OF THE DOCK LEVELER WHEN IT IS BEING PLACED INTO THE PIT. FAILURE TO FOLLOW THIS WARNING CAN ALLOW THE DOCK LEVELER TO HIT SOMEONE, CAUSING SERIOUS INJURY OR DEATH.

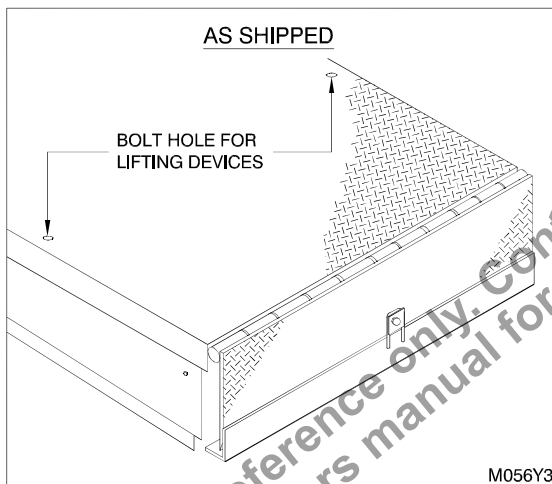

Figure 4: Bolt Hole Locations

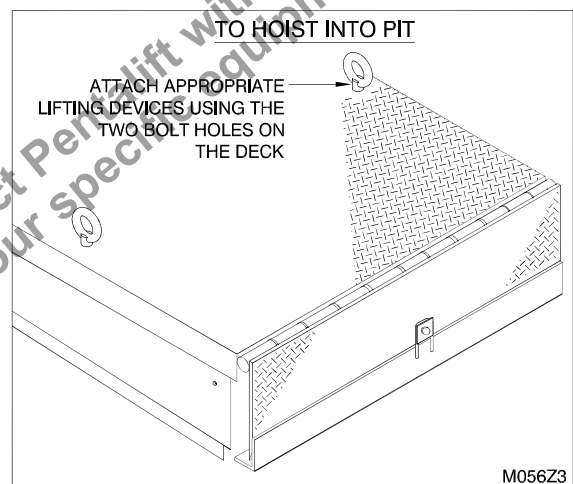

Figure 5: Attach Lifting Devices

6. \_\_\_ Install an appropriate lifting device into the two supplied holes and nuts (5/8"-11 UNC) in the dock leveler (See "Figure 5: Attach Lifting Devices" on page 8).
7. \_\_\_ For units with a nominal depth of 20" being installed into a deeper pit, proceed to the "INSTALLATION USING SHIM KIT" on page 15.
8. \_\_\_ Confirm that all steps of the installation instructions have been completed. Fill out the following information.

\_\_\_\_\_  
**Installer Name (Print)**

\_\_\_\_\_  
**Installer Signature**

\_\_\_\_\_  
**Date Installation Completed**

## SELF-CONTAINED POWER UNIT

1. \_\_\_ Hoist leveler into pit with appropriate chain and lifting devices (See “Figure 6: Hoist Leveler with Chain” on page 9) and position the leveler into the pit opening. The dock leveler must not be lifted in any other manner.

Note: Assure temporary wire is accessible through front of dock leveler. (“Figure 7: Accessible Temporary Wire” on page 10)

2. \_\_\_ Assure 1" clearance is maintained between the side of leveler platform and the side pit wall and that rear angle of dock is tight with rear curb angle.
3. \_\_\_ Remove the lifting devices. Some units come equipped with a front U-Bracket and washer while others come equipped with a front Half Moon Bracket. If your unit comes with the front U-Bracket then **remove** the front shipping bolt and washer, then **remove** the U-bracket and clean up the remaining weld to ensure there is no interference with the lip operation. If your unit comes with the Half Moon Bracket, first **remove** the front shipping bolt and **remove** the Half Moon Bracket and clean up the remaining weld to ensure there is no interference with the lip operation. (“Figure 6: Hoist Leveler with Chain” on page 9)
4. \_\_\_ Raise dock leveler by connecting the temporary wire from power supply to temporary wire supplied with dock leveler. (“Figure 7: Accessible Temporary Wire” on page 10)

**⚠ DANGER** - WIRING MUST BE DONE BY A QUALIFIED ELECTRICIAN.  
 - ALWAYS USE APPROPRIATE LOCK-OUT PROCEDURES DURING ANY ELECTRICAL INSTALLATIONS.  
 - ASSURE SUPPLY VOLTAGE IS CORRECT.  
 - ON 3 PHASE UNITS ASSURE PHASE POLARITY IS CORRECT.  
 - ALWAYS OBSERVE ALL APPLICABLE ELECTRICAL CODES.

**NOTE:** The temporary wires supplied are intended to be used for lifting the deck for the initial installation only. Once the maintenance stand is in position, the temporary wires are to be removed from both the power supply and the dock leveler. Permanent wiring must be installed immediately.

**NOTE:** The temporary wires should be connected only if they meet the requirements of the applicable local electrical codes. If they do not, the electrician should rewire to meet all applicable codes prior to applying any electrical power.

**NOTE:** The temporary wires must be wired to a push-button control in order to raise the deck. Never wire the temporary wires directly to a power supply.

5. \_\_\_ Once the deck reaches its maximum raised height with the lip fully extended, support the dock leveler as instructed in the “SUPPORTING THE LEVELER FOR MAINTENANCE” on page 50.

**⚠ CAUTION** The maintenance stand of this dock leveler is designed for use only when the dock leveler is securely welded into the dock leveler pit. Use of the stand is not recommended if the dock leveler is not securely welded into the pit (see “Figure 13: Hydraulic Dock Back Angle Weld of Dock Leveler” on page 12). To support the dock leveler at times when installation welding is not in place, an auxiliary maintenance stand that supports the dock leveler more centered on the dock leveler width is recommended. See “Pentalift auxiliary maintenance stand” on page 52.

6. \_\_\_ Support the lower half of the toe guard and remove the self tapping screw which holds it in the shipping position. Carefully lower the toe guard and avoid pinch points. (“Figure 6: Hoist Leveler with Chain” on page 9)

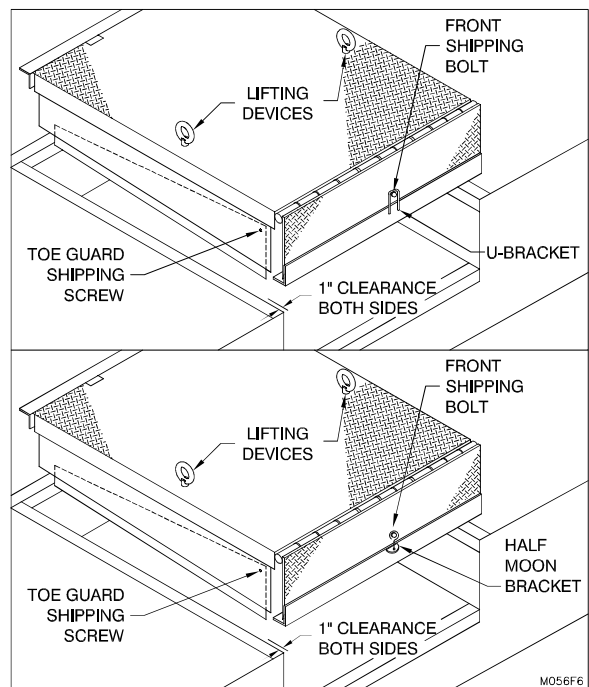

**Figure 6: Hoist Leveler with Chain**

# **⚠ DANGER**

**DO NOT DISCONNECT THE TEMPORARY POWER SUPPLY UNTIL MAINTENANCE STAND IS IN POSITION. DECK WILL AUTOMATICALLY LOWER WHEN POWER IS DISCONNECTED OR PUSH BUTTON IS RELEASED. ONCE MAINTENANCE STAND IS SECURELY IN PLACE, DISCONNECT TEMPORARY POWER SUPPLY.**

## **STAY CLEAR OF THE EQUIPMENT'S OPERATING PATH AT ALL TIMES.**

7.  Mount the push button in an appropriate location. (Figure 8: Push Button Location on page 8)

8.  Remove temporary wire from motor.

9.  Feed electrical line through conduit from push button to power unit and connect as per wiring diagram supplied.

10.  Connect main power supply to push button.

**NOTE:** Power unit requires full voltage at motor. Wire size should be sufficiently sized to prevent line voltage drop when motor is under load. ("ELECTRICAL REFERENCE CHART" on page 27)

11.  Confirm that all steps of the installation instructions have been completed. Fill out the following information.

\_\_\_\_\_  
**Installer Name (Print)**

\_\_\_\_\_  
**Installer Signature**

\_\_\_\_\_  
**Date Installation Completed**

## **REMOTE POWER UNIT**

1.  Mount push button and power unit on wall. ("Figure 9: Power Unit and Push Button" on page 11) Confirm the hose(s) length is sufficient to accommodate the desired routing path from the equipment to the power unit. Mount the power unit horizontally with reservoir breather facing up.

2.  Hoist the leveler into the pit with chain using only the appropriate lifting devices ("Figure 6: Hoist Leveler with Chain" on page 9) while feeding the hydraulic hose through the 3" O.D. conduit from inside of the pit to the power unit.

**NOTE:** The hydraulic hose is located under the dock leveler. Hoses must stay connected to the cylinders.

3.  Connect two hydraulic lines to the Pentalogic hydraulic manifold on the power unit (one hydraulic hose from lip cylinder and one hydraulic hose from lift cylinder.) "Figure 10: Pentalogic Hydraulic Manifold" on page 11

- **WIRING MUST BE DONE BY A QUALIFIED ELECTRICIAN.**
- **ALWAYS USE APPROPRIATE LOCK-OUT PROCEDURES DURING ANY ELECTRICAL INSTALLATIONS.**
- **ASSURE SUPPLY VOLTAGE IS CORRECT.**
- **ON 3 PHASE UNITS ASSURE PHASE POLARITY IS CORRECT. INCORRECT POLARITY WILL CAUSE THE MOTOR TO RUN BACKWARDS RESULTING IN CAVITATION AND POSSIBLE DAMAGE TO THE PUMP.**
- **ALWAYS OBSERVE ALL APPLICABLE ELECTRICAL CODES.**

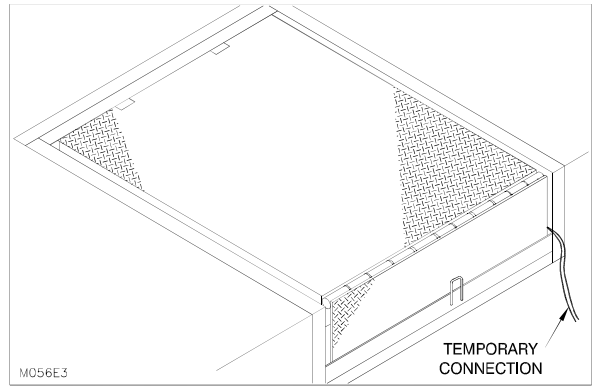

**Figure 7: Accessible Temporary Wire**

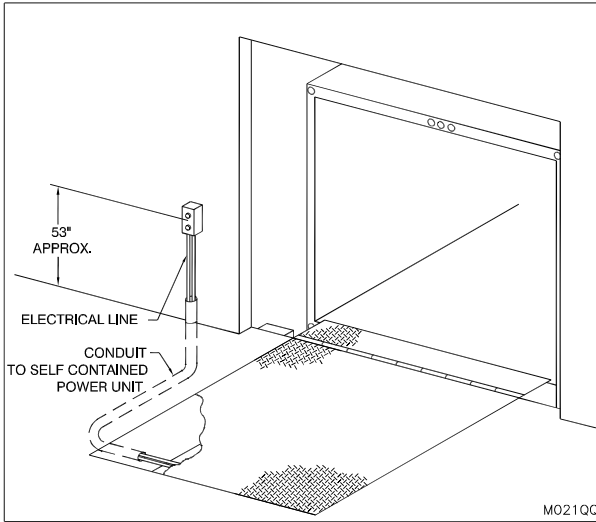

**Figure 8: Push Button Location**

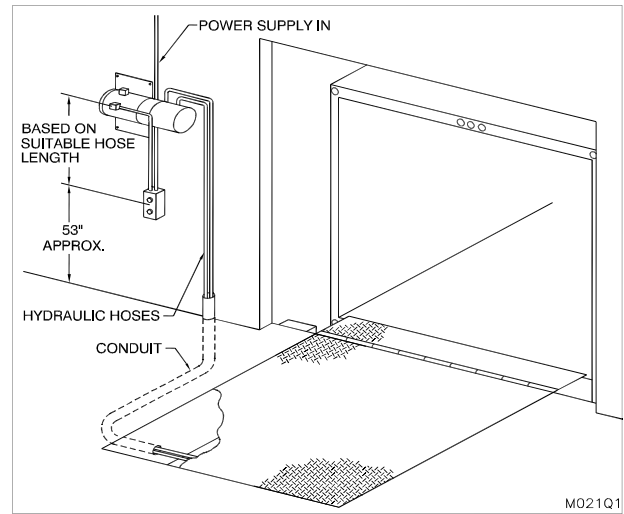

**Figure 9: Power Unit and Push Button**

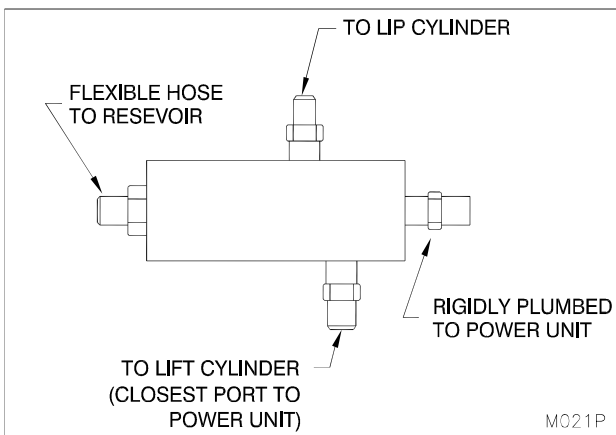

**Figure 10: Pentalogic Hydraulic Manifold**

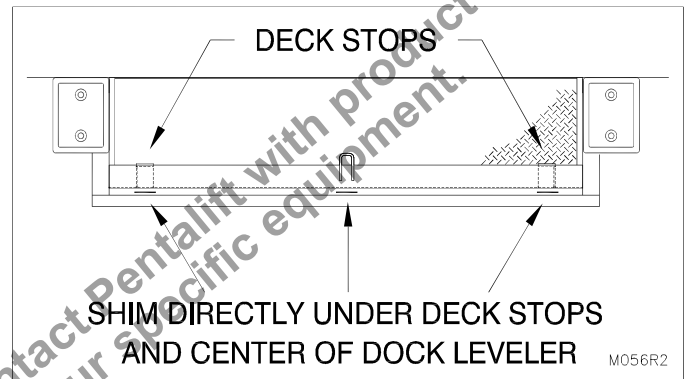

**Figure 11: Hydraulic Dock Front Shims**

4.  Install permanent electrical lines as per applicable electrical diagram provided in control panel.

**NOTE:** Power unit requires full voltage at motor. Wire size should be sufficiently sized to prevent voltage drop when motor is under load. (“ELECTRICAL REFERENCE CHART” on page 27)

Remove top and front shipping bolts. (Items 1 and 2 on “Figure 6: Hoist Leveler with Chain” on page 9)

Raise dock leveler to its maximum height and support according to the “SUPPORTING THE LEVELER FOR MAINTENANCE” on page 50.



**The maintenance stand of this dock leveler is designed for use only when the dock leveler is securely welded into the dock leveler pit. Use of the stand is not recommended if the dock leveler is not securely welded into the pit (see “Figure 13: Hydraulic Dock Back Angle Weld of Dock Leveler” on page 12). To support the dock leveler at times when installation welding is not in place, an appropriate generic maintenance stand that supports the dock leveler more centered on the dock leveler width is recommended.**

5.  Proceed to leveling instructions on page 12.
6.  Confirm that all steps of the installation instructions have been completed. Fill out the following information.

\_\_\_\_\_  
**Installer Name (Print)**

\_\_\_\_\_  
**Installer Signature**

\_\_\_\_\_  
**Date Installation Completed**

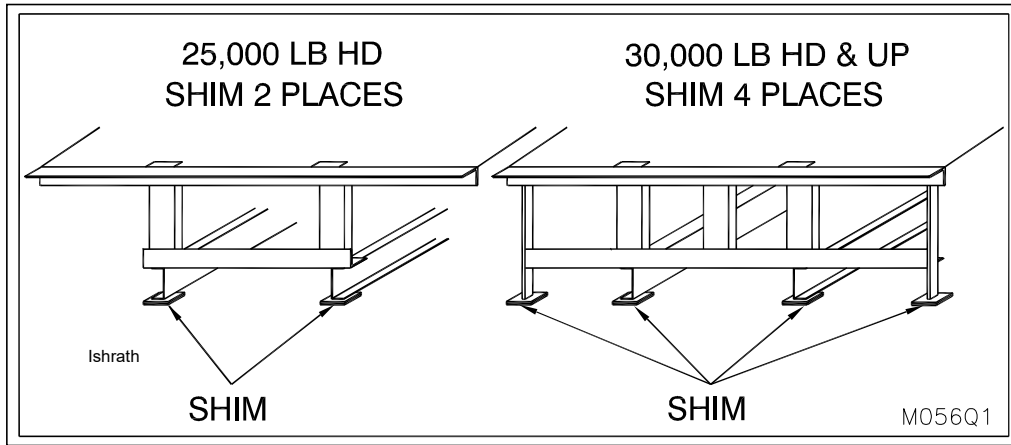

Figure 12: Hydraulic Dock Rear Shims

**UNITS EQUIPPED WITH AUTO RETURN:**

Run auto return limit switch wire through conduit as shown on applicable pit drawing and hook up in accordance with electrical schematic supplied. See page 44 for Auto Return Adjustment.

**LEVELING INSTRUCTIONS (NOT FOR ROLL-OFF STOP MODELS)**

1. \_\_\_ Place shims of minimum length and width of 3" by 4" and a minimum thickness of 14 gauge under rear frame until top rear of dock leveler is flush with rear curb angle. (See "Figure 12: Hydraulic Dock Rear Shims" on page 12) Tack weld into position.
2. \_\_\_ Lower dock leveler to the stored position and shim front frame under the two deck stops and in center of dock leveler until the deck is flush with the top of the front curb angle and the floor. (See "Figure 11: Hydraulic Dock Front Shims" on page 11) Tack weld into position.
3. \_\_\_ Confirm that the back angle of dock leveler is firmly against and flush with the top of the rear curb angle and that the dock leveler remains square in the pit before continuing.
4. \_\_\_ Make sure the rear pit curb angle is straight and level prior to installation. Make sure the dock leveler rear frame angle (or flat bar) is straight to match the rear pit curb angle. If the rear frame angle (or flat bar) is not straight then force the angle back to match the straight rear pit curb angle using a wedging device between the frame angle and the back of the deck as shown in "Figure 15: Wedging the Rear Frame Angle to the Rear Pit Curb Angle" on page 13. Tack weld the straightened angle to the rear pit curb angle. Repeat the wedging process as required over the length for the rear frame angle.
5. \_\_\_ Weld back angle of dock leveler to rear curb angle as shown in "Figure 13: Hydraulic Dock Back Angle Weld of Dock Leveler" on page 12, using the welding reference and notes on page 26 as a guide.
6. \_\_\_ Raise the dock leveler to its maximum height and support in accordance with the "SUPPORTING THE LEVELER FOR MAINTENANCE" on page 50.

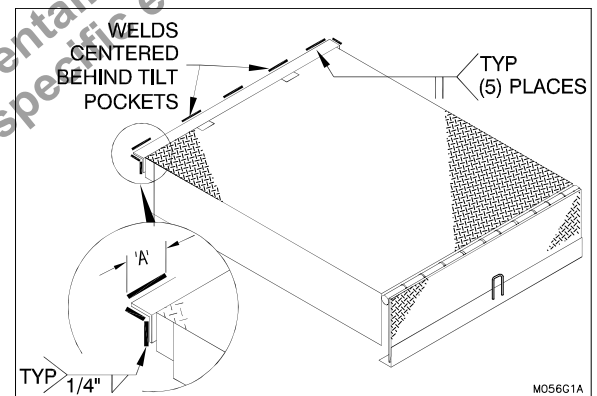

Figure 13: Hydraulic Dock Back Angle Weld of Dock Leveler

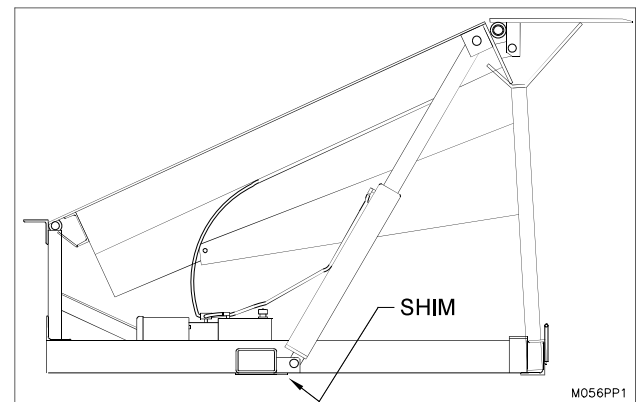

Figure 14: Hydraulic Dock Lift Cylinder Shim

# ⚠ DANGER

It is imperative that the lift cylinder clevis is properly supported. If unable to shim beneath the cylinder lower clevis plate due to insufficient pit dimensions, consult your authorized Pentalift representative for alternative support recommendations.

**NOTE:** All shim stacks must be welded together.

7.      Finish welding the front (3" long welds) and rear shim stacks to the frame of the dock leveler.
8.      Shim under hydraulic lift cylinder lower clevis plate and weld securely in place. ("Figure 14: Hydraulic Dock Lift Cylinder Shim" on page 12)
9.      Weld or bolt bumpers in place.
10.     Clean and paint welds using Tremclad High Performance Rust Enamel (Gloss Dark Machine Grey).
11.     Mount Dock Leveler warning and operating instructions placard close to the Dock Leveler in a location that assures an unobstructed view and Complete Legibility at all times.
12.     Lubricate and test in accordance with the "BREAK-IN AND PERFORMANCE CHECK" on page 45.
13.     Confirm that all steps of the installation instructions have been completed. Fill out the following information.

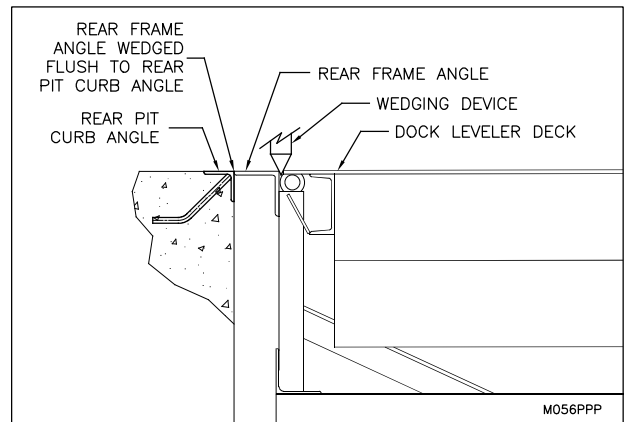

**Figure 15: Wedging the Rear Frame Angle to the Rear Pit Curb Angle**

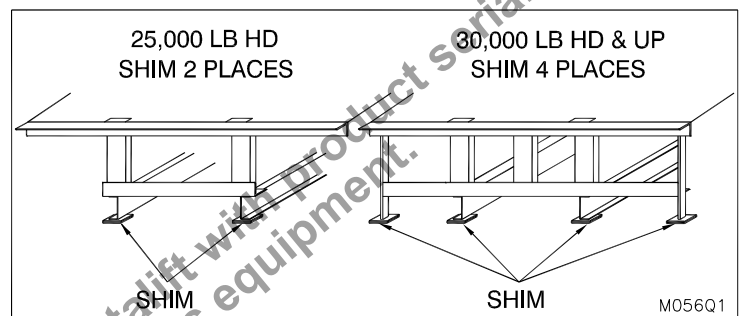

**Figure 16: Hydraulic Dock Roll-Off Stop Rear Shims**

\_\_\_\_\_  
**Installer Name (Print)**

\_\_\_\_\_  
**Installer Signature**

\_\_\_\_\_  
**Date Installation Completed**

## LEVELING INSTRUCTIONS (FOR ROLL-OFF STOP MODELS)

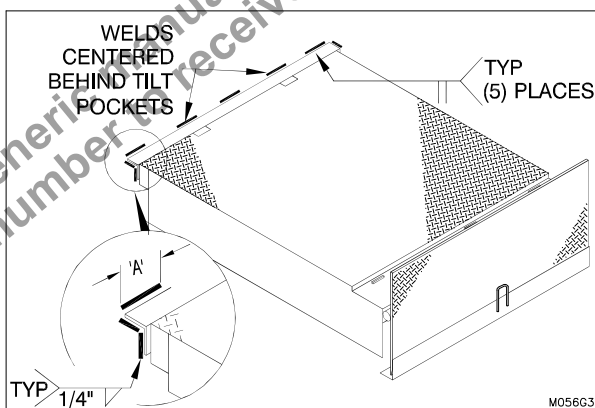

**Figure 18: Hydraulic Dock Roll-Off Stop Back Angle Weld of Dock Leveler**

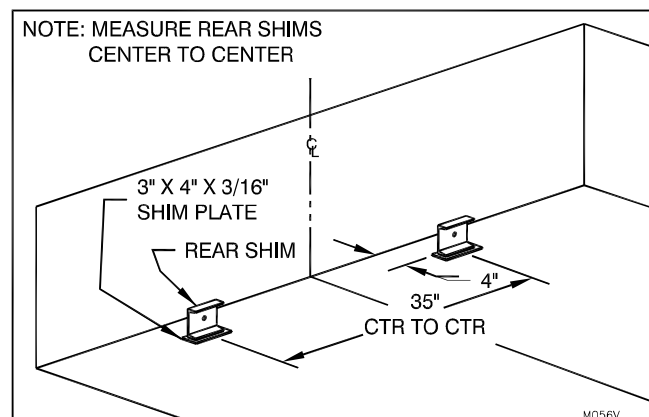

**Figure 19: Rear Shim Location (4" High Rear Shim Shown)**

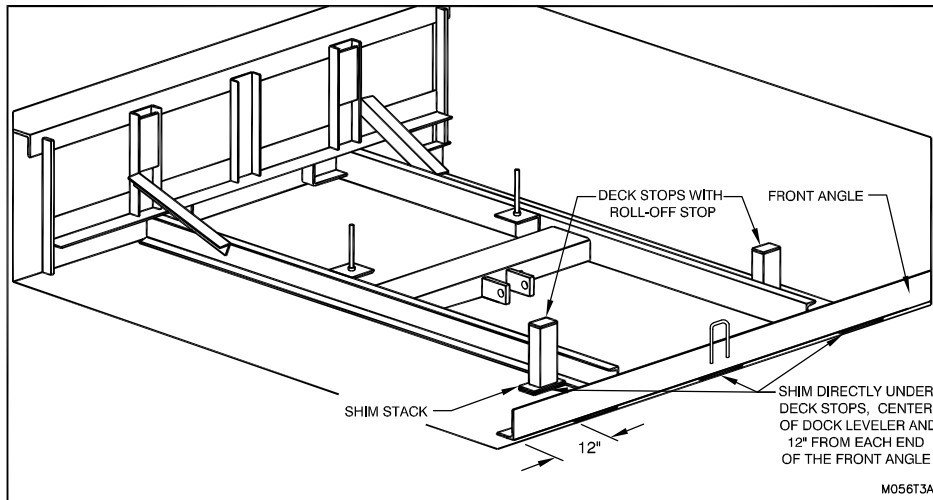

**Figure 17: Hydraulic Dock Roll-Off Stop Front Shims**

1. \_\_\_ Place shims of minimum length and width of 3" by 4" and a minimum thickness of 14 gauge under rear frame until top rear of dock leveler is flush with rear curb angle. (See "Figure 16: Hydraulic Dock Roll-Off Stop Rear Shims" on page 13 for shims placement.) Tack weld into position.
  2. \_\_\_ Lower dock leveler to the stored position and shim front frame under the two deck stops, shim in center of front angle and 12" from each end of the front angle until the deck is flush with the top of the front curb angle and the floor. (See "Figure 17: Hydraulic Dock Roll-Off Stop Front Shims" on page 14 for shims placement.) Tack weld into position.
  3. \_\_\_ Confirm that the back angle of dock leveler is firmly against and flush with the top of the rear curb angle and that the dock leveler remains square in the pit before continuing.
  4. \_\_\_ Make sure the rear pit curb angle is straight and level prior to installation. Make sure the dock leveler rear frame angle (or flat bar) is straight to match the rear pit curb angle. If the rear frame angle (or flat bar) is not straight then force the angle back to match the straight rear pit curb angle using a wedging device between the frame angle and the back of the deck as shown in "Figure 15: Wedging the Rear Frame Angle to the Rear Pit Curb Angle" on page 13. Tack weld the straightened angle to the rear pit curb angle. Repeat the wedging process as required over the length for the rear frame angle.
  5. \_\_\_ Weld back angle of dock leveler to rear curb angle as shown in "Figure 18: Hydraulic Dock Roll-Off Stop Back Angle Weld of Dock Leveler" on page 13 using the welding reference and notes on page 26 as a guide.
  6. \_\_\_ Raise the dock leveler to its maximum height and support in accordance with the "SUPPORTING THE LEVELER FOR MAINTENANCE" on page 50.
  7. \_\_\_ Finish welding the front (3" long welds) and rear shim stacks to the frame of the dock leveler.
  8. \_\_\_ Shim under hydraulic lift cylinder lower clevis plate and weld securely in place. ("Figure 20: Hydraulic Dock Roll-Off Stop Lift Cylinder Shim" on page 15)
  9. \_\_\_ It is imperative that the lift cylinder clevis is properly supported. If unable to shim beneath the cylinder lower clevis plate due to insufficient pit dimensions, consult your authorized Pentalift representative for alternative support recommendations.
- NOTE:** All shim stacks must be welded together.
10. \_\_\_ Weld or bolt bumpers in place.
  11. \_\_\_ Clean and paint welds using Tremclad High Performance Rust Enamel (Gloss Dark Machine Grey).
  12. \_\_\_ Mount Dock Leveler warning and operating instructions placard close to the Dock Leveler in a location that assures an unobstructed view and Complete Legibility at all times.

13. \_\_\_ Lubricate and test in accordance with the “BREAK-IN AND PERFORMANCE CHECK” on page 45.
14. \_\_\_ Confirm that all steps of the installation instructions have been completed. Fill out the following information.

\_\_\_\_\_  
**Installer Name (Print)**

\_\_\_\_\_  
**Installer Signature**

\_\_\_\_\_  
**Date Installation Completed**

## INSTALLATION USING SHIM KIT

For units with a nominal depth of 20” being installed into a deeper pit, it will be necessary to install a shim kit. Shim kits are available in standard heights of 1”, 2”, 3” and 4”.

### SELF CONTAINED POWER UNIT

1. \_\_\_ For 3” or 4” shim kits, weld two rear shims (see Table A) to a single shim plate each (3” x 4” x minimum ASTM A-36 or CSA G40.21 supplied by others) as shown in “Figure 22: Rear Shim (4” Shim Kit Shown)” on page 16. This step adds stability to the shims while installing the dock. This step is not required for 1” or 2” shim kits as the blocks are sufficiently stable as supplied.

Table A - Rear Shims	
4” Shim Kit	C4 Channel x 25 3/8” or 39” Long
3” Shim Kit	C3 Channel x 4” Long
2” Shim Kit	2” x 3” x 3/16” Rect. Tube x 4” Long
1” Shim Kit	1” x 3” Flat Bar x 4” Long

Note: On 25,000 lb models, there will be two rear shims; on 30,000 lb HD models and higher capacities, there will be four rear shims. Do not weld the outer rear shims (30,000 lb HD models and higher capacities) at this time.

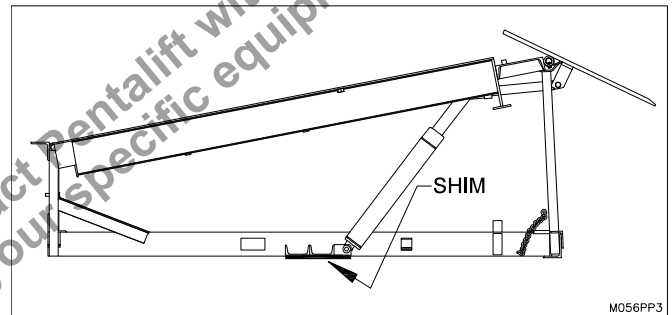

**Figure 20: Hydraulic Dock Roll-Off Stop Lift Cylinder Shim**

2. \_\_\_ Place the front-angle shim assembly into the pit at the front edge, centered across the dock leveler and pit width. When the front-angle shim is constructed of C-channel (3” & 4” shim kits) ensure the short pieces (12” long) on each end are installed toward the inside of the pit. See “Figure 24: Installation Shims (4” Shim Kit Channel Shim Shown)” on page 19.
3. \_\_\_ Place the two rear shims with welded-on shim plate at the rear of the pit, 35” center to center and 4” from the rear pit wall. (“Figure 19: Rear Shim Location(4” High Rear Shim Shown)” on page 13)

**⚠ DANGER** NEVER GO BENEATH THE DOCK LEVELER UNLESS IT IS PROPERLY SUPPORTED ON THE FRONT SHIMS, THE REAR ANGLE IS SECURELY WELDED AND THE MAINTENANCE STAND IS ENGAGED.

4. \_\_\_ Hoist leveler into pit with chain using only appropriate lifting devices (“Figure 6: Hoist Leveler with Chain” on page 9) and position the leveler into the pit opening. Note: Assure temporary wire is accessible through front of dock leveler. (“Figure 21: Installing Leveler into Pit” on page 16).
5. \_\_\_ Assure 1” clearance is maintained between the side of leveler platform and the side pit wall and that the rear angle of the dock is firmly against the rear curb angle. (“Figure 6: Hoist Leveler with Chain” on page 9)

6. \_\_\_ Confirm that the back angle of the dock leveler is firmly against and flush with the top of the rear curb angle and that the dock leveler has remained square in the pit before continuing.
7. \_\_\_ Weld the rear angle of the dock leveler to the rear curb angle, 1" wide butt weld, at the location of each tilt bar pocket (2 places). "Figure 21: Installing Leveler into Pit" on page 16.
8. \_\_\_ Lower the dock leveler until the front angle of the dock leveler rests on the front-angle shim. Ensure the front-angle shim assembly is flush with the front angle of the dock leveler frame. "Figure 24: Installation Shims (4" Shim Kit Channel Shim Shown)" on page 19.
9. \_\_\_ Weld the front-angle shim to the dock leveler frame.
10. \_\_\_ Remove the top shipping bolts and lifting devices. Some units come equipped with a front U-Bracket while others come equipped with a front Half Moon Bracket. If your unit comes with the front U-Bracket then remove the front shipping bolt then remove the U-bracket and clean up the remaining weld to ensure there is no interference with the lip operation. If your unit comes with the Half Moon Bracket, first remove the front shipping bolt and finally remove the Half Moon Bracket and clean up the remaining weld to ensure there is no interference with the lip operation. ("Figure 6: Hoist Leveler with Chain" on page 9)
11. \_\_\_ Connect the temporary wire from the power supply to the temporary wire supplied with the dock leveler. ("Figure 7: Accessible Temporary Wire" on page 10)

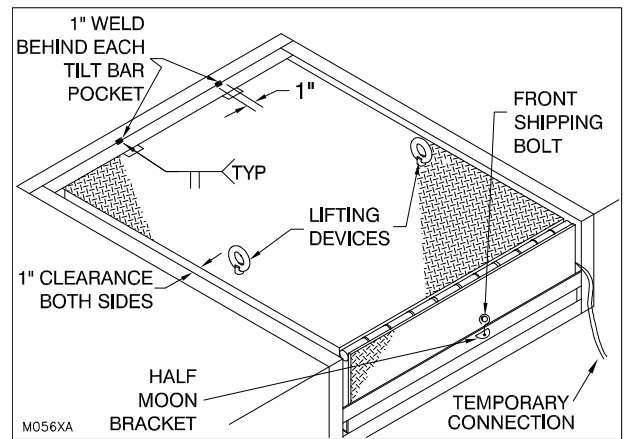

**Figure 21: Installing Leveler into Pit**

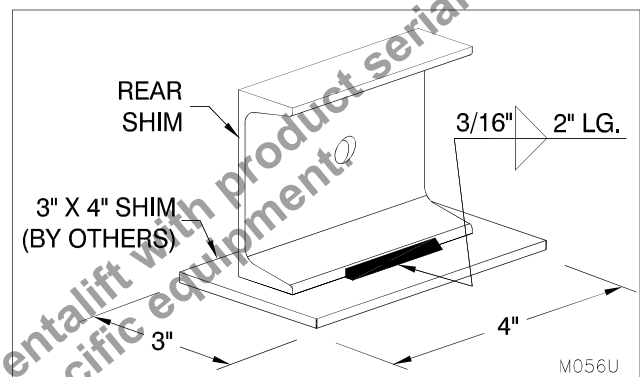

**Figure 22: Rear Shim (4" Shim Kit Shown)**



- WIRING MUST BE DONE BY A QUALIFIED ELECTRICIAN.
- ALWAYS USE APPROPRIATE LOCK-OUT PROCEDURES DURING ANY ELECTRICAL INSTALLATIONS.
- ASSURE SUPPLY VOLTAGE IS CORRECT.
- ON 3 PHASE UNITS ASSURE PHASE POLARITY IS CORRECT.
- ALWAYS OBSERVE ALL APPLICABLE ELECTRICAL CODES.

**NOTE:** The temporary wires supplied are intended to be used for lifting the deck for the initial installation only. Once the maintenance stand is in position, the temporary wires are to be removed from both the power supply and the dock leveler. Permanent wiring must be installed immediately.

**NOTE:** The temporary wires should be connected only if they meet the requirements of the applicable local electrical codes. If they do not, the electrician should rewire to meet all applicable codes prior to applying any electrical power.

**NOTE:** The temporary wires must be wired to a push-button control in order to raise the deck. Never wire the temporary wires directly to a power supply.

12. \_\_\_ Cycle the dock leveler through the raise and lower functions several times to re-align after shipping.
13. \_\_\_ Return the dock to the stored position.
14. \_\_\_ Add shims (3" x 4" x required thickness) to increase the front height of the dock until the deck plate is flush with the dock height (or at desired final level). Ensure shims are located beneath the front-angle shim at the location of the two deck stops as well as at the center of the front angle. (See "Figure 24: Installation Shims (4" Shim Kit Channel Shim Shown)" on page 19) All shims are to be minimum ASTM A-36 or CSA G40.21 material.

15. \_\_\_ Weld all shims in the stack to the front-angle shim, the front pit curb angle, and each other (3" long weld).
16. \_\_\_ Complete welding the back angle of the dock leveler to the rear pit curb angle as shown in "Figure 13: Hydraulic Dock Back Angle Weld of Dock Leveler" on page 12.
17. \_\_\_ Raise the deck to its maximum raised height with the lip fully extended and support the dock leveler as instructed in the "SUPPORTING THE LEVELER FOR MAINTENANCE" on page 50.



**NEVER GO BENEATH THE DOCK LEVELER UNLESS IT IS PROPERLY SUPPORTED ON THE FRONT SHIMS, THE REAR ANGLE IS SECURELY WELDED AND THE MAINTENANCE STAND IS ENGAGED.**

18. \_\_\_ Add shims (3" x 4" x required thickness) between the pit floor and the rear shim to close any gap and fully support the rear of the dock. Fully weld the two rear shims to the frame of the dock leveler and all shim plates in the stack to each other as well as to the rear shim.
19. \_\_\_ For 30,000 HD models and higher capacities, weld the additional two rear shims to the outside support bar of the frame as shown in "Figure 23: 30,000 lb + Outer Rear Shims (4" Shim Kit Channel Shim Shown)" on page 17 and shim until they are fully supported. Weld all of the shims to each other as well as to the dock leveler frame.

Table A - Rear Shims	
4" Shim Kit	C4 Channel x 25 3/8" or 39" Long
3" Shim Kit	C3 Channel x 4" Long
2" Shim Kit	2" x 3" x 3/16" Rect. Tube x 4" Long
1" Shim Kit	1" x 3" Flat Bar x 4" Long

**NOTE:** For 4" Shim Kit, on 25,000 lb and 30,000 lb HC models, there will be one rear shim; on 30,000 lb HD models and higher capacities, there will be two.

**NOTE:** On 25,000 lb and 30,000 lb HC models, there will be two rear shims; on 30,000 lb HD models and higher capacities, there will be four.

**NOTE:** All shim stacks must be welded together.

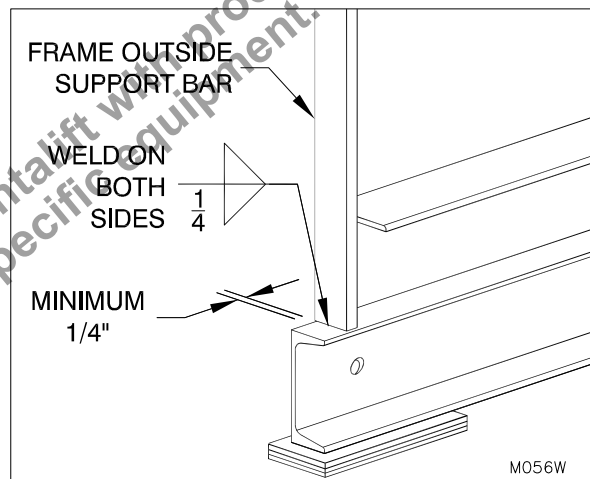

**Figure 23: 30,000 lb + Outer Rear Shims (4" Shim Kit Channel Shim Shown)**

20. \_\_\_ Weld the 4" long cylinder shim assembly(s) to the underside of the cylinder thrust beam with the front of the cylinder shim assembly flush with the front edge of the clevis support plate. ("Figure 24: Installation Shims (4" Shim Kit Channel Shim Shown)" on page 19)
21. \_\_\_ Place additional 3" x 4" x desired thickness shims (as necessary) under the cylinder shim at the cylinder clevis location(s).
22. \_\_\_ Weld the cylinder shim and shim plates to the thrust beam as well as to each other.
23. \_\_\_ Support the lower half of the toe guard and remove the self tapping screw which holds it in the shipping position. Carefully lower the toe guard and avoid pinch points. ("Figure 6: Hoist Leveler with Chain" on page 9)
24. \_\_\_ Mount the push button in an appropriate location. ("Figure 8: Push Button Location" on page 11)



**DONOTDISCONNECTTHETEMPORARYPOWERSUPPLYUNTILMAINTENANCESTAND ISINPOSITION.DECKWILLAUTOMATICALLYLOWERWHENPOWERISDISCONNECTED ORPUSHBUTTONISRELEASED.ONCEMAINTENANCESTANDISSECURELYINPLACE, DISCONNECT TEMPORARY POWER SUPPLY.**

**STAY CLEAR OF THE EQUIPMENT'S OPERATING PATH AT ALL TIMES.**

- 25.  Remove temporary wire from motor.
  - 26.  Feed electrical line through conduit from push button to power unit and connect as per wiring diagram supplied.
  - 27.  Connect main power supply to push button.
- NOTE:** Power unit requires full voltage at motor. Wire size should be sufficiently sized to prevent line voltage drop when motor is under load. (“ELECTRICAL REFERENCE CHART” on page 27)
- 28.  Weld or bolt bumpers in place.
  - 29.  Clean and paint the welds using Tremclad High Performance Rust Enamel (Gloss Dark Machine Grey).
  - 30.  Touch up any scratches, abrasions or paint damage that exist. Pentalift standard gray paint matches with Tremclad High Performance Rust Enamel (Gloss Dark Machine Grey).
  - 31.  Mount dock leveler warning and operating instructions placard close to the Dock Leveler in a location that assures an unobstructed view and Complete Legibility at all times.
  - 32.  Lubricate and test in accordance with the “BREAK-IN AND PERFORMANCE CHECK” on page 45.
  - 33.  Confirm that all steps of the installation instructions have been completed. Fill out the following information.

\_\_\_\_\_  
**Installer Name (Print)**

\_\_\_\_\_  
**Installer Signature**

\_\_\_\_\_  
**Date Installation Completed**

**Note On Capacity:** The dock leveler capacity indicated on the serial plate must be divided with a factor to accommodate dynamic loading factors. For more information see Pentalift document - Dock Leveler Capacity – Understanding Loading Dock Capacity at <http://www.pentalift.com/dock-leveler-capacity.php>

Generic manual for reference only. Contact Pentalift with product serial number to receive owners manual for your specific equipment.

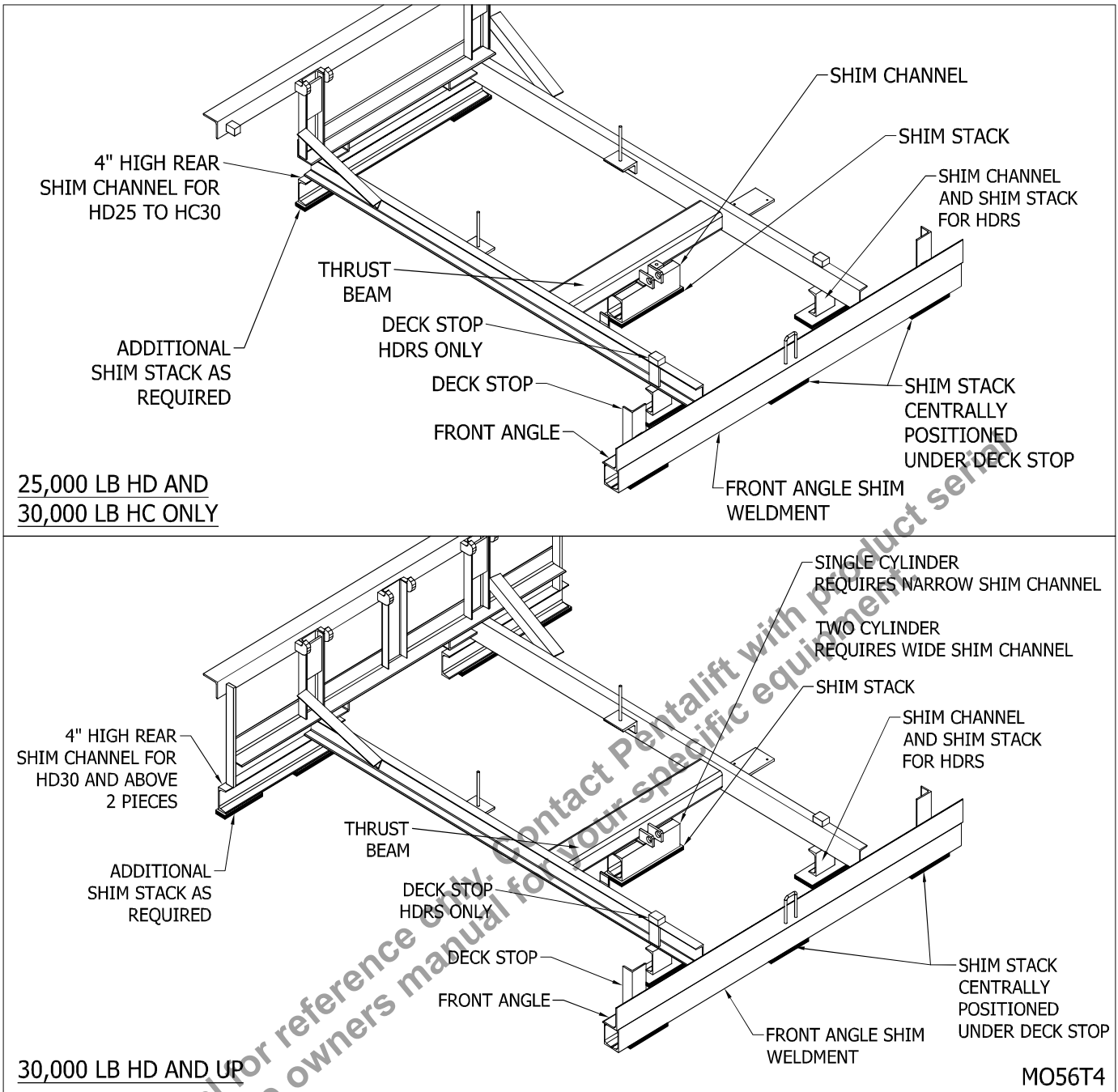

Figure 24: Installation Shims (4" Shim Kit Channel Shim Shown)

## REMOTE POWER UNIT

1. \_\_\_ For 3" or 4" shim kits, weld two rear shims (see Table A) to a single shim plate each (3" x 4" x minimum ASTM A-36 or CSA G40.21 supplied by others) as shown in "Figure 22: Rear Shim (4" Shim Kit Shown)" on page 16. This step adds stability to the shims while installing the dock. This step is not required for 1" or 2" shim kits as the blocks are sufficiently stable as supplied.

4" Shim Kit	C4 Channel x 4" Long
3" Shim Kit	C3 Channel x 4" Long
2" Shim Kit	2" x 3" x 3/16" Rect. Tube x 4" Long
1" Shim Kit	1" x 3" Flat Bar x 4" Long

Note: On 30,000 lb HD models and higher capacities, there will be four rear shims. Do not weld the outer rear shims (30,000 lb HD models and higher capacities) at this time.

2. \_\_\_ Place the front-angle shim assembly into the pit at the front edge, centered across the dock leveler and pit width. When the front-angle shim is constructed of C-channel (3" & 4" shim kits) ensure the short pieces (12" long) on each end are installed toward the inside of the pit. "Figure 24: Installation Shims (4" Shim Kit Channel Shim Shown)" on page 19.
3. \_\_\_ Place the two rear shims with welded-on shim plate at the rear of the pit, 35" center to center and 4" from the rear pit wall. ("Figure 19: Rear Shim Location(4" High Rear Shim Shown)" on page 13)
4. \_\_\_ Mount push button and power unit on wall. ("Figure 8: Push Button Location" on page 11) Mount the power unit horizontally with reservoir breather facing up.
5. \_\_\_ Hoist the leveler into the pit with chain using only the lifting brackets provided on the leveler as points of attachment ("Figure 6: Hoist Leveler with Chain" on page 9) while feeding the hydraulic hose through the 3" O.D. conduit from inside of the pit to the power unit.

**NOTE:** The hydraulic hose is located under the dock leveler. Hoses must stay connected to the cylinders.

6. \_\_\_ Connect the two hydraulic lines to the Pentalogic hydraulic manifold on the power unit (one hydraulic hose from lip cylinder and one hydraulic hose from lift cylinder). ("Figure 10: Pentalogic Hydraulic Manifold" on page 11)
7. \_\_\_ Assure 1" clearance is maintained between the side of the leveler platform and the side pit wall ("Figure 6: Hoist Leveler with Chain" on page 9) and that the rear angle of the dock is firmly against the rear curb angle.
8. \_\_\_ **Confirm that the back angle of the dock leveler is firmly against and flush with the top of the rear curb angle and that the dock leveler has remained square in the pit before continuing.**
9. \_\_\_ Weld the rear angle of the dock leveler to the rear curb angle, 1" wide butt weld, at the location of each tilt bar pocket (2 places). See "Figure 21: Installing Leveler into Pit" on page 16.
10. \_\_\_ Lower the dock leveler until the front angle of the dock leveler rests on the front-angle shim. Ensure the front-angle shim assembly is flush with the front angle of the dock leveler frame. "Figure 24: Installation Shims (4" Shim Kit Channel Shim Shown)" on page 19.
11. \_\_\_ Weld the front-angle shim to the dock leveler frame.
12. \_\_\_ Install permanent electrical lines as per applicable electrical diagram provided in control panel.

**NOTE:** Power unit requires full voltage at motor. Wire size should be sufficiently sized to prevent voltage drop when motor is under load. (See "ELECTRICAL REFERENCE CHART" on page 27)

## **⚠ DANGER**

- **WIRING MUST BE DONE BY A QUALIFIED ELECTRICIAN.**
- **ALWAYS USE APPROPRIATE LOCK-OUT PROCEDURES DURING ANY ELECTRICAL INSTALLATIONS.**
- **ENSURE SUPPLY VOLTAGE IS CORRECT.**
- **ON 3 PHASE UNITS ASSURE PHASE POLARITY IS CORRECT.**
- **ALWAYS OBSERVE ALL APPLICABLE ELECTRICAL CODES.**

13.  Remove the lifting chain, top and front shipping bolts and lifting brackets. (See “Figure 6: Hoist Leveler with Chain” on page 9)
14.  Cycle the dock leveler through the raise and lower functions several times to re-align after shipping.
15.  Return the dock to the stored position.
16.  Add shims (3” x 4” x required thickness) to increase the front height of the dock until the deck plate is flush with the dock height (or at desired final level). Ensure shims are located beneath the front-angle shim at the location of the two deck stops as well as at the center of the front angle. (See “Figure 24: Installation Shims (4” Shim Kit Channel Shim Shown)” on page 19) All shims are to be minimum ASTM A-36 or CSA G40.21 material.
17.  Weld all shims in the stack to the front-angle shim, the front pit curb angle, and each other (3” long weld).
18.  Complete welding the back angle of the dock leveler to the rear pit curb angle as shown in “Figure 13: Hydraulic Dock Back Angle Weld of Dock Leveler” on page 12.
19.  Raise the dock leveler and support the deck and lip as instructed in the “SUPPORTING THE LEVELER FOR MAINTENANCE” on page 50.

## **⚠ DANGER**

**NEVER GO BENEATH THE DOCK LEVELER UNLESS IT IS PROPERLY SUPPORTED ON THE FRONT SHIMS, THE REAR ANGLE IS SECURELY WELDED AND THE MAINTENANCE STAND IS ENGAGED.**

20.  Add shims (3” x 4” x required thickness) between the pit floor and the rear shim to close any gap and fully support the rear of the dock. Fully weld the two rear shims to the frame of the dock leveler and all shim plates in the stack to each other as well as to the rear shim.
21.  For 30,000 HD models and higher capacities, weld the additional two rear shims to the outside support bar of the frame as shown in “Figure 23: 30,000 lb + Outer Rear Shims (4” Shim Kit Channel Shim Shown)” on page 17 and shim until they are fully supported. Weld all of the shims to each other as well as to the dock leveler frame.

**NOTE:** All shim stacks must be welded together.

22.  Weld the 4” long cylinder shim assembly(s) to the underside of the cylinder thrust beam with the front of the cylinder shim assembly flush with the front edge of the clevis support plate. (See “Figure 24: Installation Shims (4” Shim Kit Channel Shim Shown)” on page 19)
23.  Place additional 3” x 4” x desired thickness shims (as necessary) under the cylinder shim at the cylinder clevis location(s).
24.  Weld the cylinder shim and shim plates to the thrust beam as well as to each other.
25.  Support the lower half of the toe guard and remove the self tapping screw which holds it in the shipping position. Carefully lower the toe guard and avoid pinch points. (“Figure 6: Hoist Leveler with Chain” on page 9)
26.  Weld or bolt bumpers in place.
27.  Clean and paint the welds using Tremclad High Performance Rust Enamel (Gloss Dark Machine Grey).
28.  Mount Dock Leveler warning and operating instructions placard close to the Dock Leveler in a location that assures an unobstructed view and Complete Legibility at all times.

29. \_\_\_ Lubricate and test in accordance with the "BREAK-IN AND PERFORMANCE CHECK" on page 45.
30. \_\_\_ Confirm that all steps of the installation instructions have been completed. Fill out the following information.

\_\_\_\_\_  
**Installer Name (Print)**

\_\_\_\_\_  
**Installer Signature**

\_\_\_\_\_  
**Date Installation Completed**

---

## INSTALLATION USING FILLER PLATE

---

### INSTALLATION INSTRUCTIONS FOR 3-INCH FILLER PLATE

1. \_\_\_ Before installing the filler plate and dock leveler, read the "INSTALLATION INSTRUCTIONS" section of the owner's manual on page 7.
2. \_\_\_ Position the 3 inch square tube against the rear curb angle and flush to the top surface of the curb angle.
3. \_\_\_ Weld the ends of the square tubing to the side curb angle ( see "Figure 25: Welding the 3 X 3 Square Tubing to the Curb Angles" on page 22. Add vertical welds at the ends of the tube between tube surface and side curb angle surface.
4. \_\_\_ Note the centerline positions of the tilt bar pockets on the dock leveler.
5. \_\_\_ Transfer the centerline positions to the square tube.
6. \_\_\_ Weld 1 inch butt weld at the mark off locations on the square tube
7. \_\_\_ Based on the dock leveler's rated capacity, see "WELDING REFERENCE INFORMATION" on page 26 to determine the length of the weld for dimension "A".
8. \_\_\_ Refer to the rest of the installation section of the owner's manual to install the dock leveler.
9. \_\_\_ Confirm that all steps of the installation instructions have been completed. Fill out the following information.

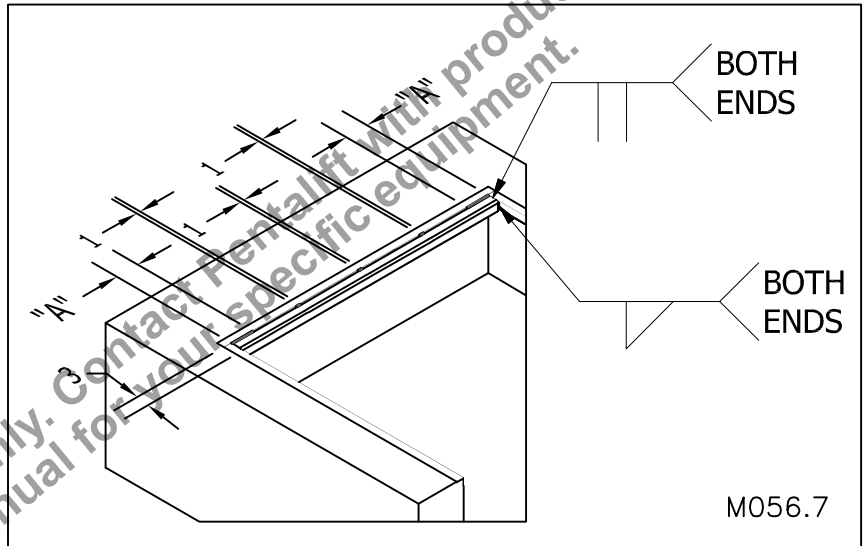

**Figure 25: Welding the 3 X 3 Square Tubing to the Curb Angles**

\_\_\_\_\_  
**Installer Name (Print)**

\_\_\_\_\_  
**Installer Signature**

\_\_\_\_\_  
**Date Installation Completed**

## INSTALLATION INSTRUCTIONS FOR 4-INCH FILLER PLATE

1.  Before installing the filler plate and dock leveler, read the "INSTALLATION INSTRUCTIONS" section of the owner's manual on page 7.
2.  Position the 4 X 3 inch rectangular tube against the rear curb angle and flush to the top surface of the curb angle.
3.  Weld the ends of the rectangular tubing to the side curb angle ( see "Figure 26: Welding the 4 X 3 Rectangular Tubing to the Curb Angles" on page 23. Add vertical welds at the ends of the tube between tube surface and side curb angle surface.

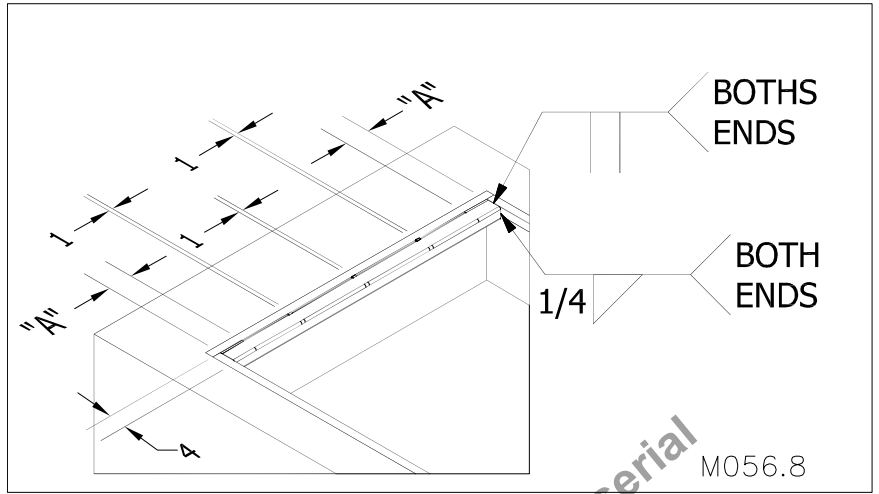

4.  Note the centerline positions of the tilt bar pockets on the dock leveler. **Figure 26: Welding the 4 X 3 Rectangular Tubing to the Curb Angles**
5.  Transfer the centerline positions to the rectangular tube.
6.  Weld 1 inch butt weld at the mark off locations on the rectangular tube
7.  Based on the dock leveler's rated capacity, see "WELDING REFERENCE INFORMATION" on page 26 to determine the length of the weld for dimension "A".
8.  Refer to the rest of the installation section of the owner's manual to install the dock leveler.
9.  Confirm that all steps of the installation instructions have been completed. Fill out the following information.

\_\_\_\_\_  
**Installer Name (Print)**

\_\_\_\_\_  
**Installer Signature**

\_\_\_\_\_  
**Date Installation Completed**

## FILLER PLATE INSTALLATION INSTRUCTIONS (WITH TWO TUBES & TWO SUPPORT BARS)

1.      Before installing the filler plate and dock leveler, read the "INSTALLATION INSTRUCTIONS" section of the owner's manual on page 7.
2.      Locate the two support bars on one of the rectangular tubes. The support bar should be positioned halfway between the center span of the tube to the end of the tube.
3.      Weld the support bars in place using full fillet welds.
4.      Slip the levelling tubes over the support bars and lightly tack in place so that it does not fall off while inverting the rectangular tube as indicated in "Figure 27: Welding the 4 X 3 Rectangular Tubing to the Curb Angles" on page 24.

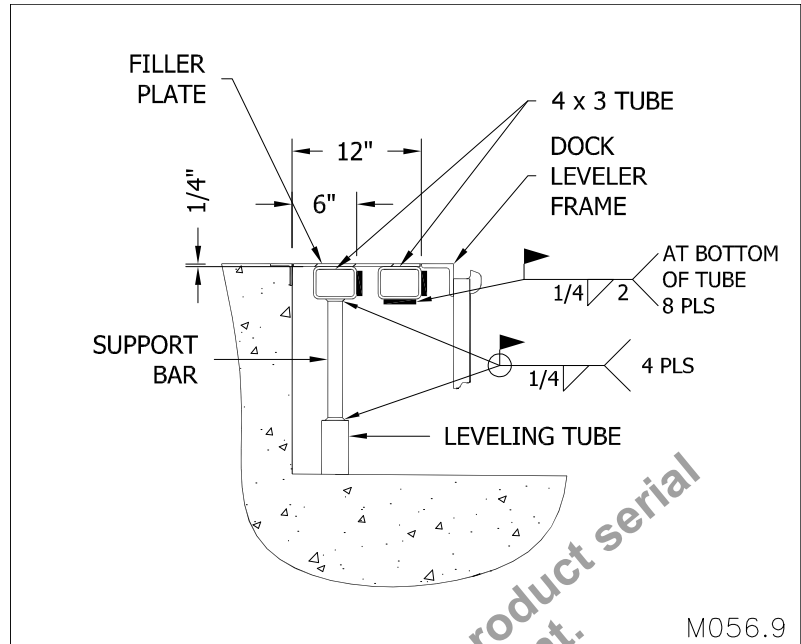

**Figure 27: Welding the 4 X 3 Rectangular Tubing to the Curb Angles**

5.      Position the 4 X 3 inch rectangular tubes as indicated in "Figure 27: Welding the 4 X 3 Rectangular Tubing to the Curb Angles" on page 24. Make sure the top surface of the rectangular tube is  $\frac{1}{4}$ " below the top surface of the curb angle. This will allow the filler plate to be welded flush to the top surface of the curb angle.
6.      Weld the ends of the rectangular tubing to the side curb angle as indicated in "Figure 27: Welding the 4 X 3 Rectangular Tubing to the Curb Angles" on page 24. Add vertical welds at the ends of the tube between tube surface and side curb angle surface.
7.      Remove the tack weld from step 4 and allow the levelling tubes to settle to the pit floor.

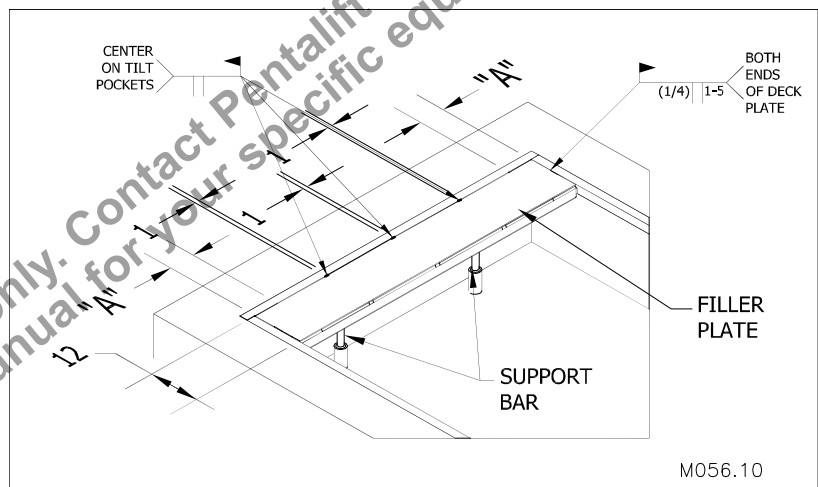

**Figure 28: Installing the filler plate**

8.      Weld the levelling tubes to the support bars using full fillet welds as indicated in "Figure 27: Welding the 4 X 3 Rectangular Tubing to the Curb Angles" on page 24.
9.      Note the centerline positions of the tilt bar pockets on the dock leveler.
10.      Transfer the centerline positions to the back side of the filler plate that will adjoin the rear curb angle.
11.      Place the filler plate on top of the rectangular tubes as indicated in "Figure 28: Installing the filler plate" on page 24 making sure the filler plate sits flat and square to the rear and side curb angles.
12.      Weld 1 inch butt weld at the mark off locations on the deck plate as indicated in "Figure 28: Installing the filler plate" on page 24.

13. \_\_\_ Based on the dock leveler's rated capacity, see "WELDING REFERENCE INFORMATION" on page 26 to determine the length of the weld for dimension "A".
14. \_\_\_ Refer to the rest of the installation section of the owner's manual to install the dock leveler.
15. \_\_\_ Confirm that all steps of the installation instructions have been completed. Fill out the following information.

\_\_\_\_\_  
**Installer Name (Print)**

\_\_\_\_\_  
**Installer Signature**

\_\_\_\_\_  
**Date Installation Completed**

### FILLER PLATE INSTALLATION INSTRUCTIONS (WITH TWO TUBES & FOUR SUPPORT BARS)

1. \_\_\_ Before installing the filler plate and dock leveler, read the "INSTALLATION INSTRUCTIONS" section of the owner's manual on page 7.
2. \_\_\_ Locate the two support bars on the rectangular tubes (two support bars per rectangular tube). The support bar should be positioned halfway between the center span of the tube to the end of the tube.
3. \_\_\_ Weld the support bars in place using full fillet welds.
4. \_\_\_ Slip the levelling tubes over the support bars and lightly tack in place so that it does not fall off while inverting the rectangular tube as indicated in "Figure 29: Welding the 4 X 3 Rectangular Tubing to the Curb Angles" on page 25.
5. \_\_\_ Position the 4 X 3 inch rectangular tubes as indicated in "Figure 29: Welding the 4 X 3 Rectangular Tubing to the Curb Angles" on page 25. Make sure the top surface of the rectangular tube is 1/4" below the top surface of the curb angle. This will allow the filler plate to be welded flush to the top surface of the curb angle.
6. \_\_\_ Weld the ends of the rectangular tubing to the side curb angle as indicated in "Figure 29: Welding the 4 X 3 Rectangular Tubing to the Curb Angles" on page 25. Add vertical welds at the ends of the tube between tube surface and side curb angle surface.
7. \_\_\_ Remove the tack weld from step 4 and allow the levelling tubes to settle to the pit floor.
8. \_\_\_ Weld the levelling tubes to the support bars using full fillet welds as indicated in "Figure 29: Welding the 4 X 3 Rectangular Tubing to the Curb Angles" on page 25.

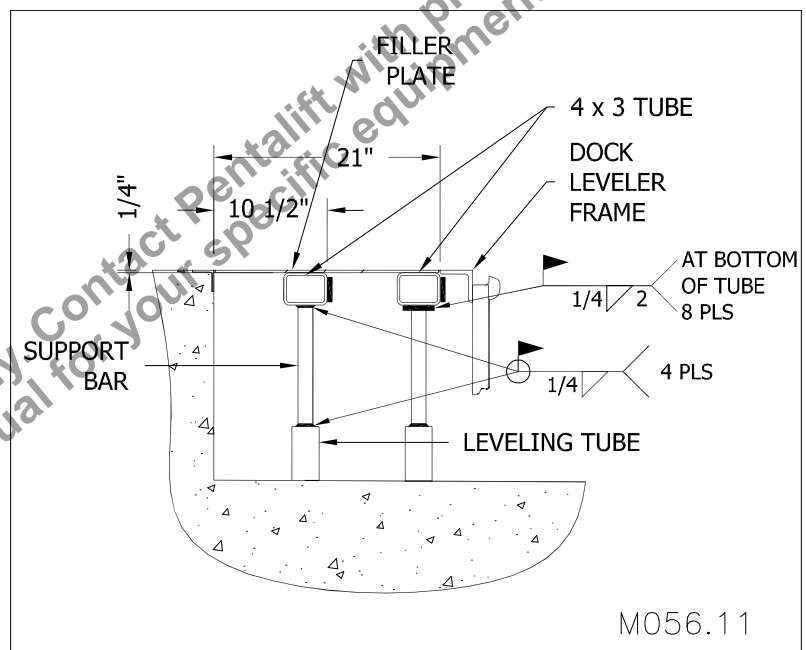

**Figure 29: Welding the 4 X 3 Rectangular Tubing to the Curb Angles**

9. \_\_\_ Note the centerline positions of the tilt bar pockets on the dock leveler.
10. \_\_\_ Transfer the centerline positions to the back side of the filler plate that will adjoin the rear curb angle.
11. \_\_\_ Place the filler plate on top of the rectangular tubes as indicated in "Figure 30: Installing the filler plate" on page 26 making sure the filler plate sits flat and square to the rear and side curb angles.
12. \_\_\_ Weld 1 inch butt weld at the mark off locations on the deck plate as indicated in "Figure 30: Installing the filler plate" on page 26.

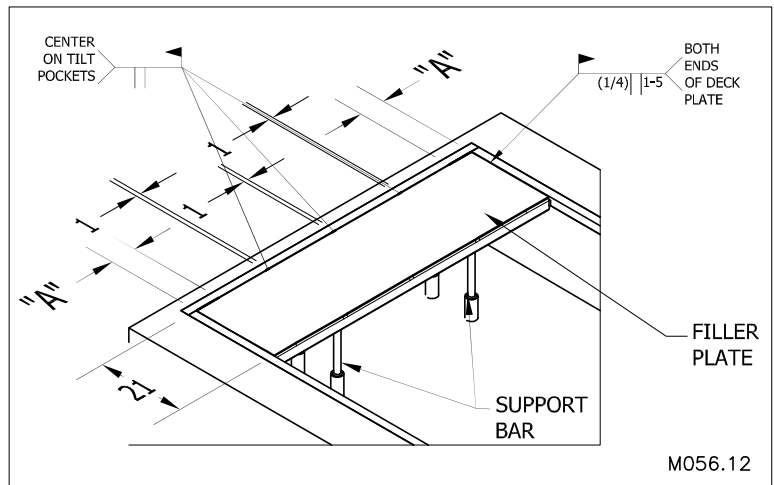

**Figure 30: Installing the filler plate**

13. \_\_\_ Based on the dock leveler's rated capacity, see "WELDING REFERENCE INFORMATION" on page 26 to determine the length of the weld for dimension "A".
14. \_\_\_ Refer to the rest of the installation section of the owner's manual to install the dock leveler.
15. \_\_\_ Confirm that all steps of the installation instructions have been completed. Fill out the following information.

\_\_\_\_\_  
**Installer Name (Print)**

\_\_\_\_\_  
**Installer Signature**

\_\_\_\_\_  
**Date Installation Completed**

### WELDING REFERENCE INFORMATION

- Observe and obey all welding safety requirements per AWS D1.1-92. (W117.2-74 in Canada.)
- Welding electrodes are to be clean and free from moisture.
- Material to be welded must be clean and free of oils, excessive millscale/rust etc.
- All craters are to be filled to a minimum of 85% of the cross sectional area of the weld.
- All under cutting is to be removed by either welding, grinding or a combination of both.
- Maximum reinforcement on butt welds is 1/8".
- Use highest current possible per chart below to obtain satisfactory weld.

<i>Electrode</i>	<b>E7018</b>	
<i>Diameter</i>	1/8"	5/32"
<i>Amperage</i>	130-150	140-180

<i>Rated Capacity</i>	<b>"A" Dimension, Figure 18, page 13</b>
30,000 lb 30,000 lb 35,000 lb 40,000 lb	3"
45,000 lb 50,000 lb 60,000 lb	6"

# ELECTRICAL REFERENCE CHART

Ensure that the thermal overload relay is set to match the full load current as shown on the motor name plate. Consult all applicable electrical codes.

<b>ELECTRICAL REFERENCE - 1.5 HP</b>								
Length of branch circuit which will have a 2% voltage drop at full load current (copper wire) ft/m.  NOTE: Calculations are based on 30 C Ambient	AWG	115/1/60	230/1/60	230/3/60	380/3/50	480/3/60	575/3/60	
	14			60.3 ft/ 18.4m	168.7 ft/ 51.4m	406.7 ft/ 124m	704 ft/ 214m	1035.1 ft/ 315.5m
	12	38.1ft/ 11.6m	152.5 ft/ 46.5m	268.2 ft/ 81.8m	646.7 ft/ 197.1m	The values given are intended to be a rough wiring guide only.  Be sure to check all applicable electrical codes before wiring.		
	10	60.6 ft/ 18.5m	242.6 ft/ 73.9m	426.8 ft/ 130.1m				
	8	96.4 ft/ 29.4m	385 ft/ 117.5m	678.2 ft/ 206.7m				
	6	153.2 ft/ 46.7m	612.9 ft/ 186.8m					
Approximate Motor Current (full load) TENV Unit	19 amps	9.5 amps	5.4 amps	3.7 amps	2.7 amps	2.2 amps		

**Note On Capacity:** The dock leveler capacity indicated on the serial plate must be divided with a factor to accommodate dynamic loading factors. For more information see Pentalift document - Dock Leveler Capacity – Understanding Loading Dock Capacity at <http://www.pentalift.com/dock-leveler-capacity.php>



**FAILURE TO PROPERLY INSTALL ANY PENTALIFT DOCK LEVELER MAY RESULT IN PROPERTY DAMAGE, BODILY INJURY OR DEATH AND WILL VOID ALL WARRANTIES.**

## INSTALLATION PICTURES

Upon completion of installation, photograph the following views as depicted below. Keep photos with owners manual.

1. \_\_\_ Front angle shims. (See "Figure 31: Front Angle & Deck Stop Shims" on page 28)
2. \_\_\_ Deck stop shims. (See "Figure 31: Front Angle & Deck Stop Shims" on page 28)

**NOTE:** Deck stops for standard dock levelers are located on the front angle.

3. \_\_\_ Rear shims (Left and Right side). (See "Figure 33: Rear Shims" on page 28)
4. \_\_\_ Thrust beam shim(s). (See "Figure 32: Thrust Beam Shim(s)" on page 28)
5. \_\_\_ Rear angle of dock leveler in parked position showing flush and level to the floor/curb angle. (See "Figure 34: Rear Angle Flush with Curb Angle" on page 29)

\_\_\_\_\_  
**Installer Name (Print)**

\_\_\_\_\_  
**Installer Signature**

\_\_\_\_\_  
**Date Installation Completed**

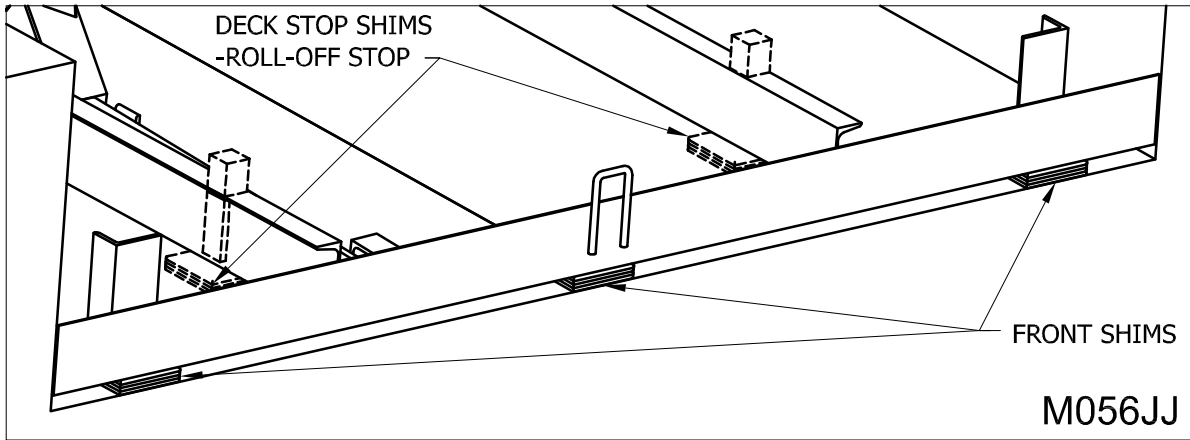

Figure 31: Front Angle & Deck Stop Shims

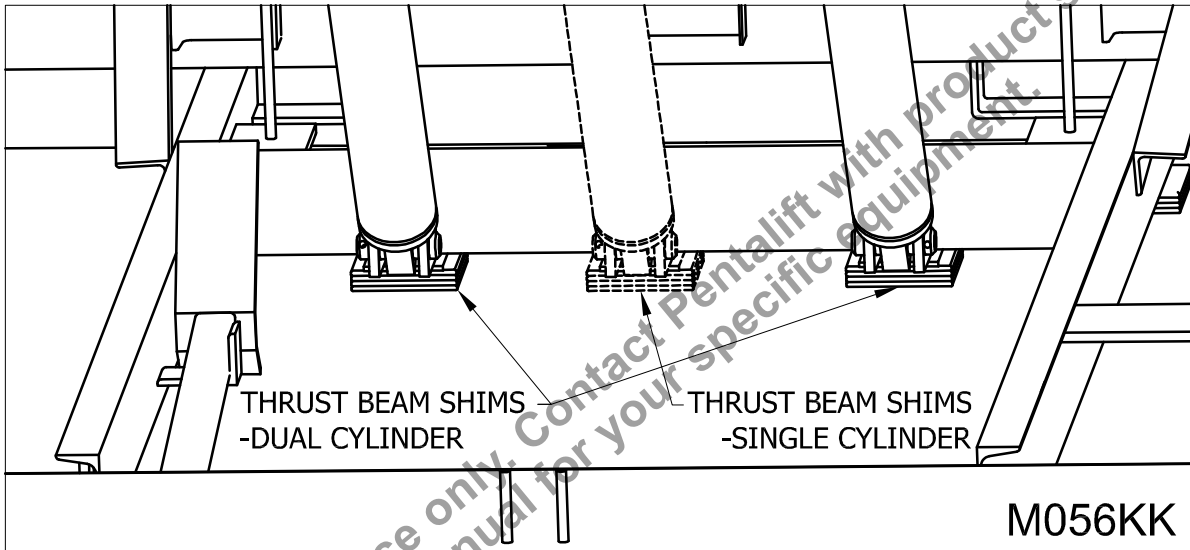

Figure 32: Thrust Beam Shim(s)

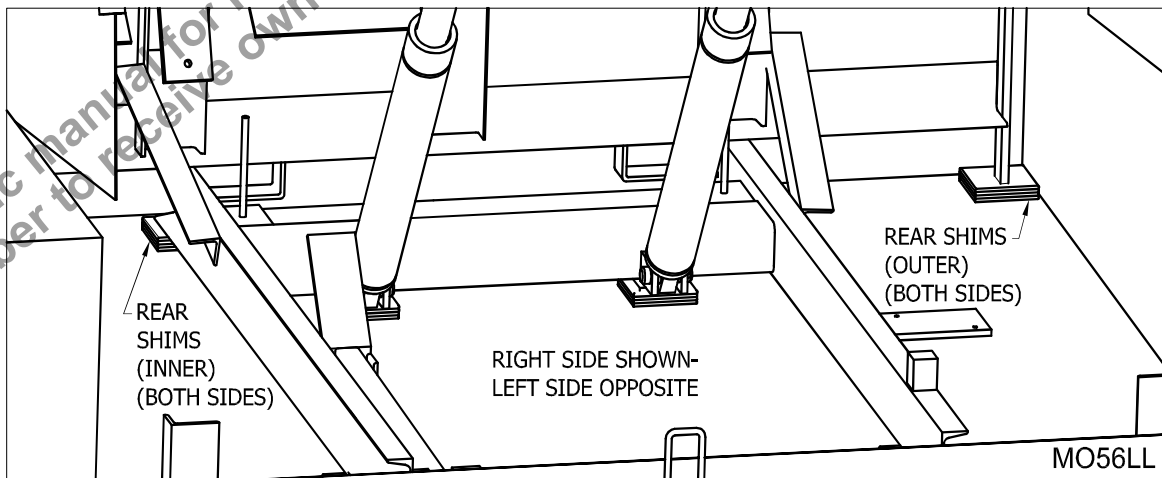

Figure 33: Rear Shims

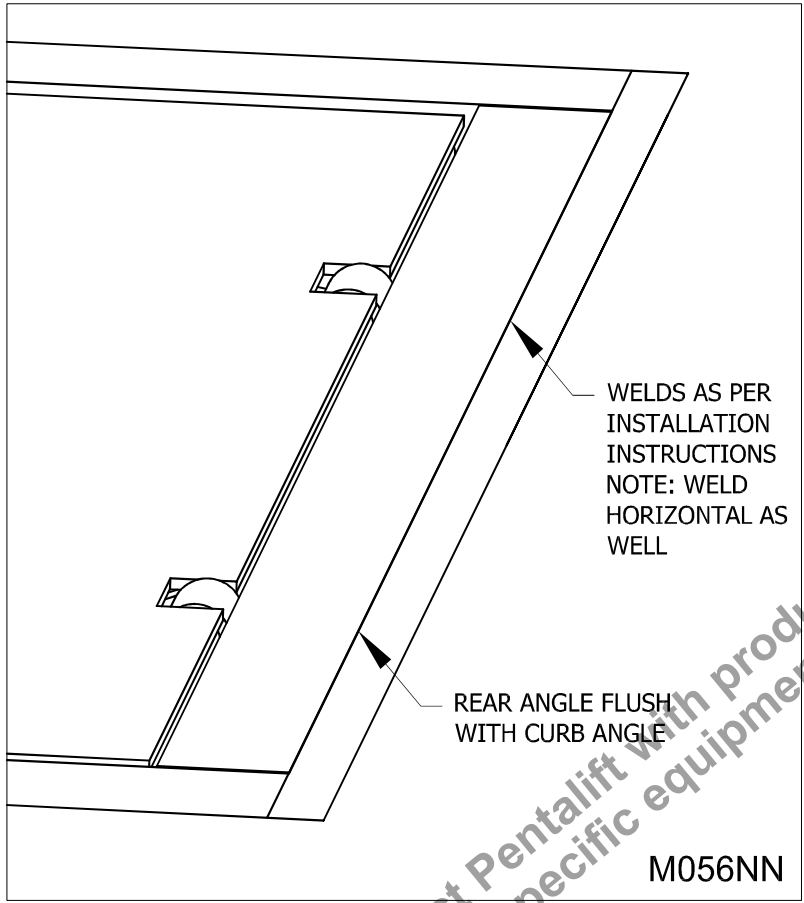
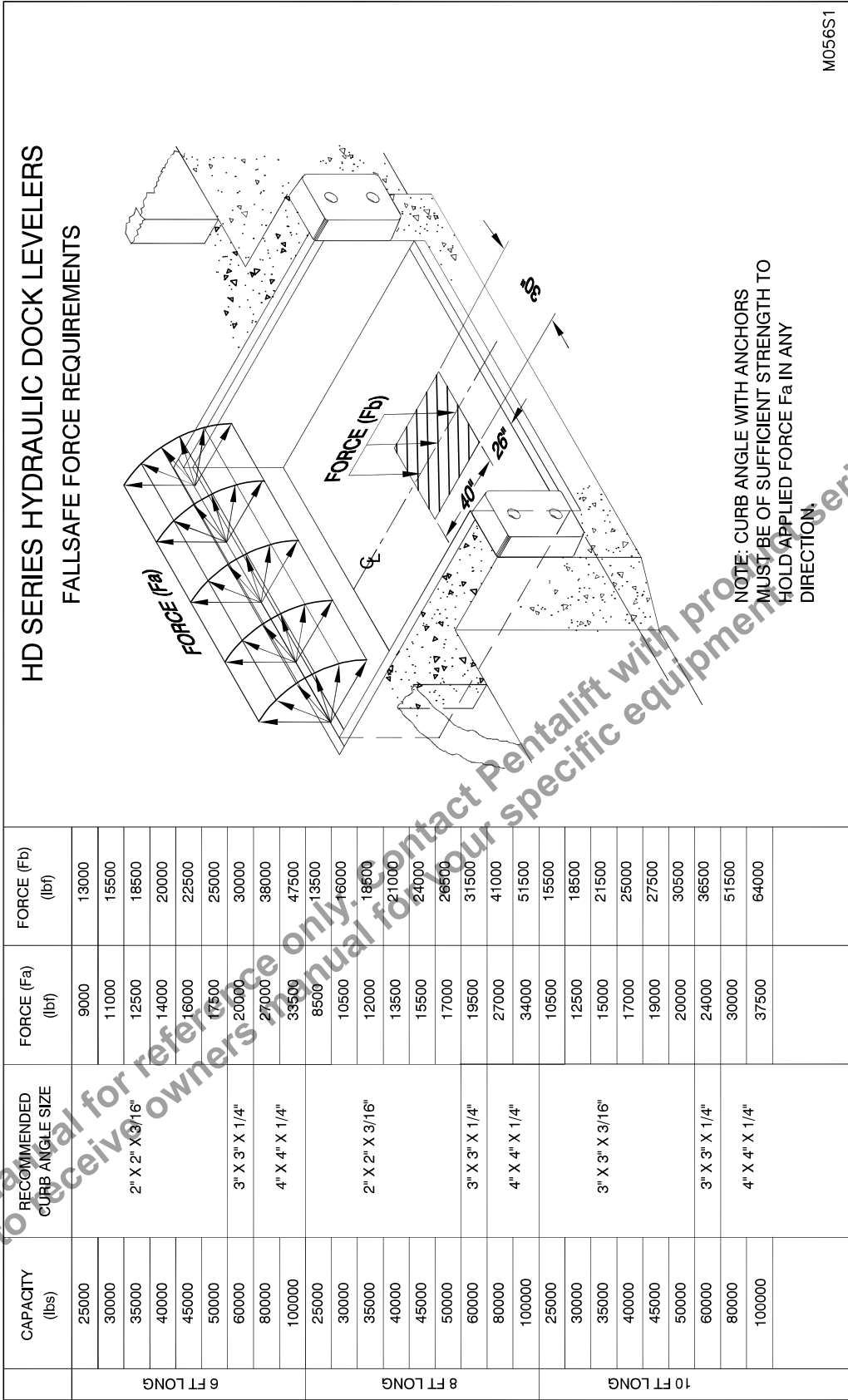

Figure 34: Rear Angle Flush with Curb Angle



M056S1

Figure 35: HD Model Curb Angle Force Chart

# INSTALLATION INSTRUCTIONS

## POUR-IN DOCK LEVELERS



**Do not install, operate or service this product unless you have read and fully understand the entire contents of this manual. Failure to do so may result in property damage, bodily injury or death.**

**NOTE:** A very high level of field issues with this type of equipment can be directly attributed to improper or incomplete installation. The installation instructions and information provided for this equipment is thorough. A step by step sequence for installation is provided. All steps must be followed and completed to provide a complete installation. Incomplete or improper installations can lead to equipment malfunction and / or damage, create safety issues and void warranties. Please follow all installation and set ups steps as indicated in the installation instructions and owner's manual. If you are unclear or uncertain regarding any of the steps contact your Pentalift representative for clarification. A copy of the completed steps listing with the sign off and photos of the installation as indicated at the conclusion of the installation instructions will be required prior to any Pentalift factory trouble shooting assistance.

---

### IMPORTANT

---

#### PREPARATION PRIOR TO INSTALLATION

---

**NOTE:** Prior to accepting shipment and pouring, check pour-in pan and structural angle for damage. Perform installation instructions in the same sequence as they are listed below. To accommodate a complete installation there is a blank space provided beside each numbered step in the installation instructions. Please check off the steps sequentially as they are completed. This will assist in confirming a complete installation.

**IMPORTANT:** In some instances shipping and handling can result in damage to the dock leveler. Prior to accepting the shipment and prior to installing the equipment check the dock leveler for damage. Be sure to check the pour-in pan components and the pour in angles (See "Figure 37: Pour-In Pan Components" on page 32).

If damage does exist;

- 1) Do not accept the shipment until you have made a damaged notation on the delivery receipt. It is the consignees obligation to count and examine the condition of the shipment at the time of the delivery.
- 2) Do not install the equipment until appropriate repairs are made.
- 3) Contact your Pentalift representative for assistance.



**Before doing any installation, maintenance, inspection or trouble shooting, barricade all areas from traffic around the work area inside (and outside if applicable) for safety and post appropriate warning signs.**

**⚠ DANGER**

Before doing any electrical work, be certain that the power is disconnected with a fused disconnect, properly tagged and locked out. Fused disconnect and lockout device (supplied and installed by others) must meet with all applicable codes and regulations. All electrical work must be performed by a qualified electrician in accordance with all applicable codes and regulations.

**⚠ DANGER**

MAKE SURE LIFTING AND SLINGING DEVICES ARE OF SUFFICIENT CAPACITY, USED IN THE CORRECT MANNER AND ARE IN GOOD WORKING ORDER. ALL LIFTING, POSITIONING AND INSTALLATION, AS WELL AS THE BREAK-IN AND PERFORMANCE CHECK MUST BE DONE BY QUALIFIED PERSONNEL TRAINED AND EXPERIENCED IN NECESSARY SAFETY PROCEDURES.

**⚠ DANGER**

NEVER GO BENEATH THE DOCK LEVELER FOR ANY REASON UNLESS THE DECK AND LIP ARE PROPERLY SUPPORTED (SEE "HOW TO SUPPORT..." IN THE OWNER'S MANUAL) AND THE POWER IS DISCONNECTED, PROPERLY TAGGED AND LOCKED OUT. IT IS THE RESPONSIBILITY OF THE OWNER TO ENSURE THAT NO LOAD NOR TRAFFIC IS PLACED ON THE DECK WHILE THE MAINTENANCE STAND IS ENGAGED. THE CONSTRUCTION OF THE MAINTENANCE STAND IS INTENDED TO SUPPORT THE WEIGHT OF THE UNLOADED DOCK LEVELER ONLY.

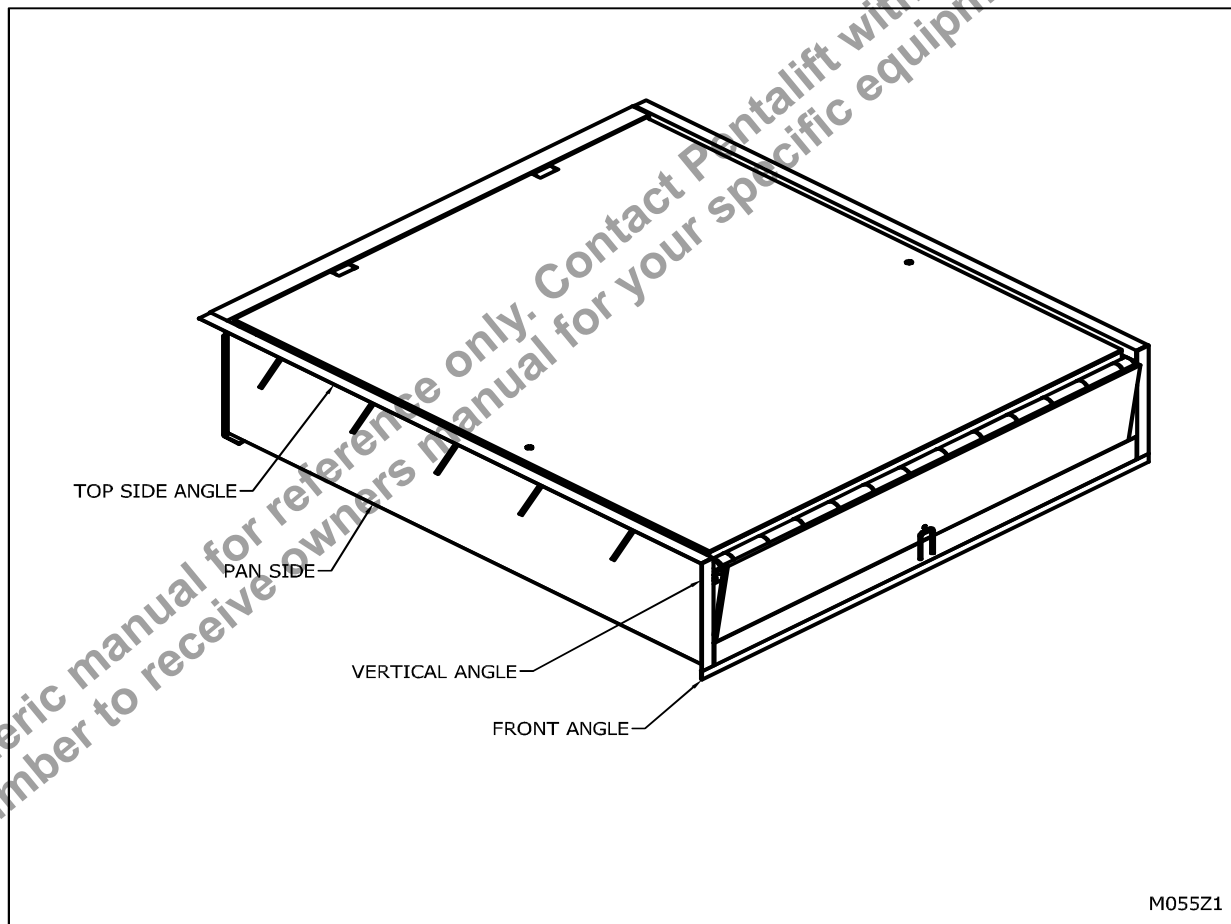
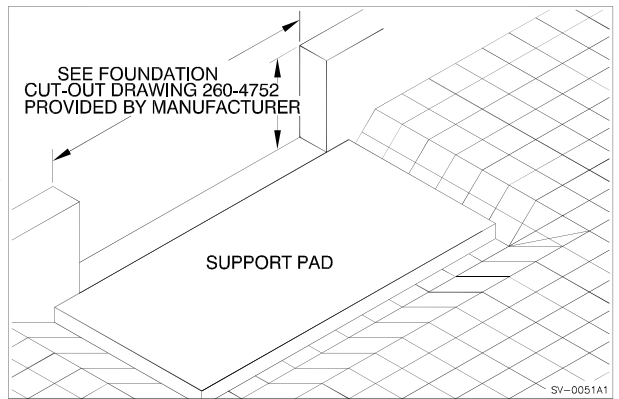

Figure 37: Pour-In Pan Components

1. \_\_\_ Provide holes in the side pan of the dock leveler for the electrical and/or hydraulic conduits. (See “Figure 44: Conduits Required” on page 36)

**NOTE: It is vital that the required connections be made through the side panel of the pour-in frame. This must be done prior to the pouring of concrete around the conduit location zone. Conduit requirements are determined from the appropriate pour-in leveler arrangement drawing, the appropriate electrical schematic for the individual dock leveler order, as well as the electrical and mechanical codes that apply to the individual installation. Conduits must be routed through the lower rear section of the pour-in panel. The conduit installation zone is indicated in “Figure 45: Conduit Installation Zone” on page 36.**



**Figure 38: Foundation cut out and support pad**

2. \_\_\_ Find the pre-determined floor level (See “Figure 38: Foundation cut out and support pad” on page 33) and ensure the foundation cut-out and support pad are in place to properly locate and support the dock leveler is appropriate according to the sizes shown on the dock leveler drawing provided by the Pentalift. For the dimensions of the foundation cut-out refer to Pentalift drawing 260-4752.
3. \_\_\_ Position the dock leveler into the foundation cutout (see “Figure 42: Dock Leveler in Position” on page 34).
4. \_\_\_ Shim the front and rear of the dock to the desired, correct and level position. Confirm side to side positioning at the pre-determined floor level.
5. \_\_\_ Ensure there is a one inch (1”) gap between the deck and side pan curb angles. Confirm this on both sides of the dock leveler. Once the gaps are confirmed as correct, ensure the adjusting bolts are in contact with the side panels. See “Figure 43: One Inch (1”) Gap” on page 34. Use the adjusting bolts to increase the gap to 1” if required.
6. \_\_\_ Securely brace the dock leveler to prevent any movement or “floating” during the pouring of the concrete. Use lag bolts in the provided lagging brackets to assist in securing the dock leveler (see “Figure 42: Dock Leveler in Position” on page 34). Note that these brackets are intended to assist in bracing the dock leveler and that consideration and use of additional supporting means may be required. Prior to installing the lags confirm that if shims are utilized the lag bolt length is increased to accommodate for the shimming, allowing proper and sufficient lag penetration into the concrete.
7. \_\_\_ Prior to pouring the concrete, confirm that pour-in pan sides and top side angles are straight and undamaged, reconfirm that the pan structure will maintain a 1” gap between edge of the dock leveler deck and the finished pan side walls for the entire length of the deck.
8. \_\_\_ Prior to pouring the concrete, re-examine the front and rear of the unit to ensure the top of the unit has remained level and in the desire final position. Once the concrete has been poured around the dock leveler, repositioning the dock leveler is very difficult and expensive. See “Figure 44: Conduits Required” on page 36. Ensure the temporary wire on hydraulic units is easily accessible. See “Figure 47: Accessible Temporary Wire” on page 37.
9. \_\_\_ Pour concrete to finished floor level and flush with the curb angle on all three (3) sides in **two stages**.

**NOTE:** Care must be taken when placing concrete around pan of the dock leveler. Excessive concrete force on the pan components will cause distortion and or deflection of the pan assembly. It may also cause the dock leveler to move from the desired final position. This could create many serious issues including and not limited to; impeding the required movement of the dock leveler. Creating misalignment of the dock leveler with the trucks and trailers, and look bad visually. It is very important to not create excessive forces onto dock leveler pan components. Concrete tampers or compactors should be used carefully as these can create high forces.

**First Stage** – allow concrete to flow under entire base of pan and ten inches (10”) up the sides. The purpose of this pour is to have the concrete flow under dock leveler for proper below frame support and to further support and hold

the dock leveler in the desired location during the second stage pour. Allow the concrete to cure to full strength.

**Second Stage** – fill to pre-determined floor level and flush with the curb angle on all three (3) sides.

10.      Remove all excess concrete.
11.      Once the concrete is cured, remove the side adjusting bolts. (see “Figure 43: One Inch (1”) Gap” on page 34)
12.      Remove the top shipping bolts (if equipped) and front shipping bolts and lifting brackets. (See “Figure 46: Shipping Wire, Bolts, and Lifting Devices.” on page 37)
13.      For any model of hydraulic dock leveler, review the position of the top edge dock leveler deck relative to the top of the curb angle (See “Figure 40: Deck Alignment” on page 35). If the deck is too low in relation to the installation requirements, shim the dock leveler using steel shim(s) on both sides as indicated in “Figure 41: Shimming 16” & 18” Lips” on page 35 and in “Figure 41A: Shimming 20” Lips” on page 35.

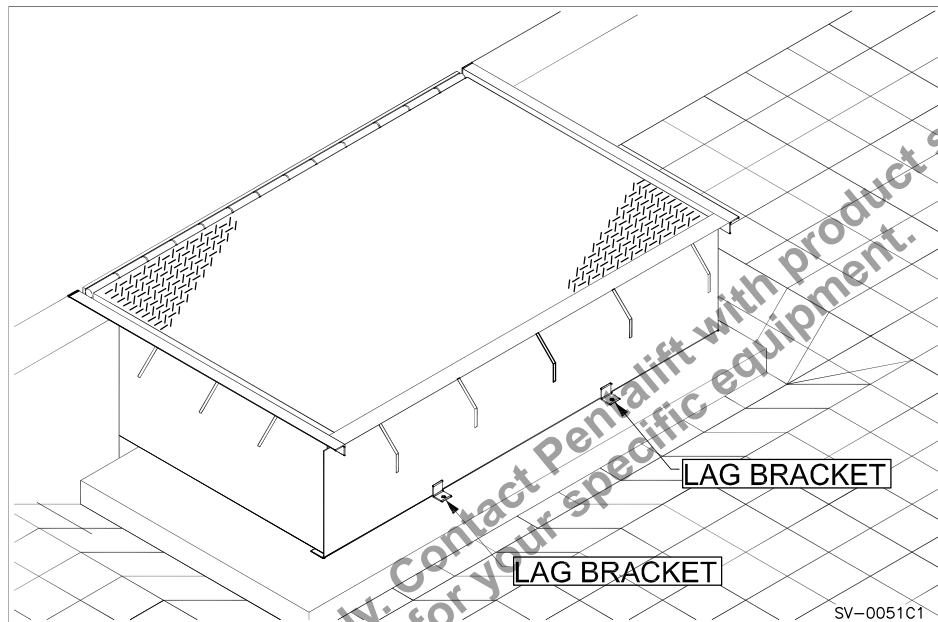

Figure 42: Dock Leveler in Position

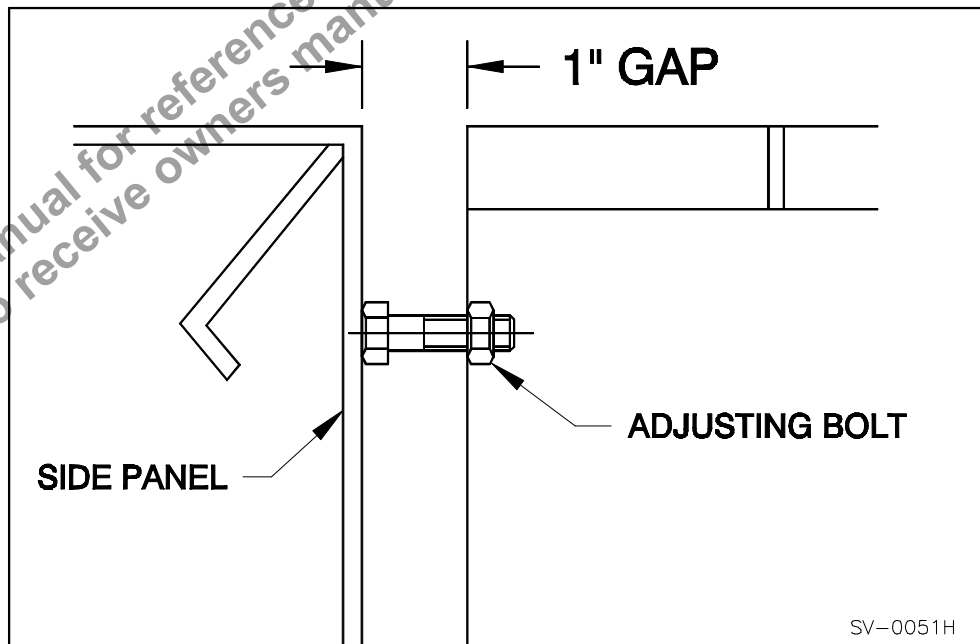
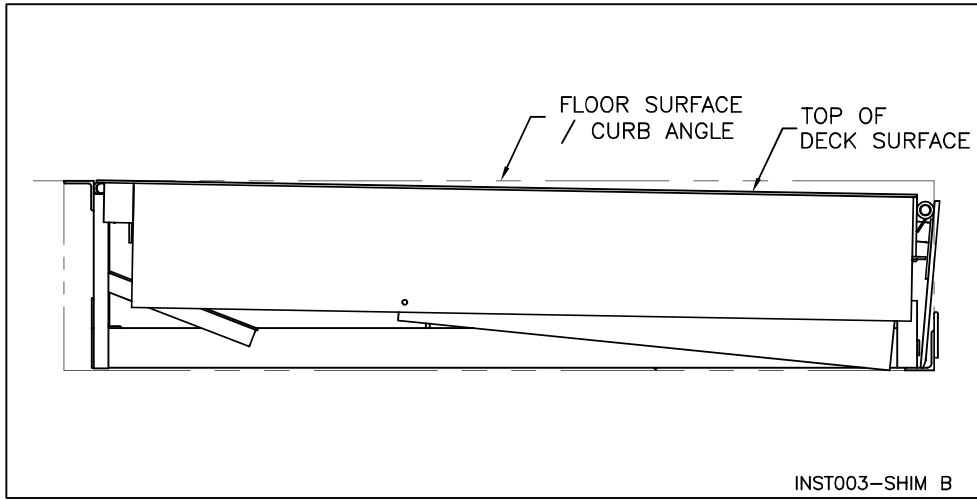
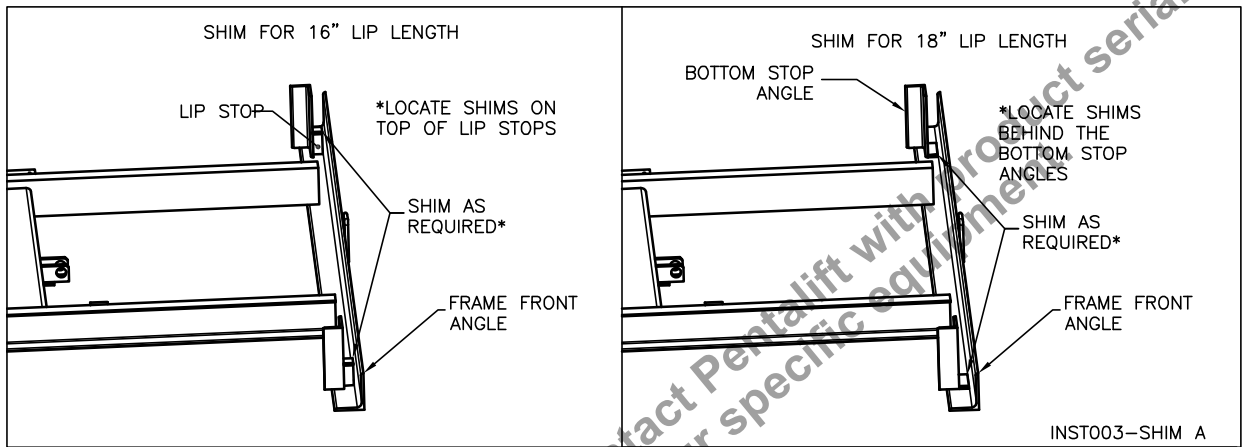

Figure 43: One Inch (1”) Gap



**Figure 40: Deck Alignment**



**Figure 41: Shimming 16" & 18" Lips**

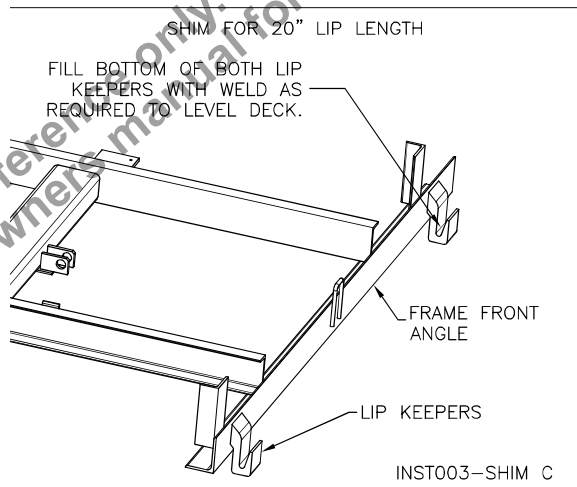

**Figure 41A: Shimming 20" Lips**

\_\_\_\_\_  
**Installer Name (Print)**

\_\_\_\_\_  
**Installer Signature**

\_\_\_\_\_  
**Date Installation Completed**

## HYDRAULIC DOCK LEVELER WITH SELF CONTAINED POWER UNIT:

1.      Raise the dock leveler by connecting the temporary cord from power supply to the temporary wire supplied with the dock leveler. (See "Figure 47: Accessible Temporary Wire" on page 37)

### **⚠ DANGER**

- WIRING MUST BE DONE BY A QUALIFIED ELECTRICIAN.
- ALWAYS USE APPROPRIATE LOCK-OUT PROCEDURES DURING ANY ELECTRICAL INSTALLATIONS.
- ASSURE SUPPLY VOLTAGE IS CORRECT.
- ON 3 PHASE UNITS ASSURE PHASE POLARITY IS CORRECT.
- ALWAYS OBSERVE ALL APPLICABLE ELECTRICAL CODES.

**NOTE:** The temporary wires supplied are intended to be used for lifting the deck for the initial installation only. Once the maintenance stand is in position, the temporary wires are to be removed from both the power supply and the dock leveler. Permanent wiring must be installed immediately.

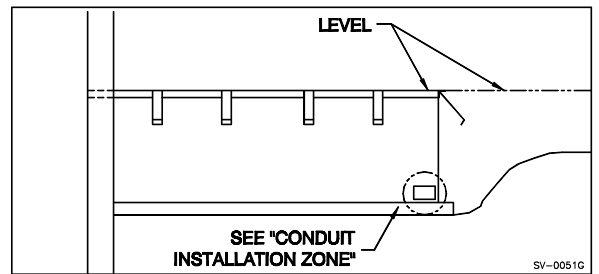

Figure 44: Conduits Required

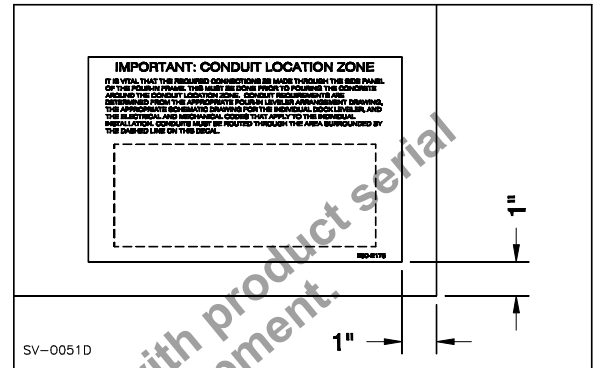

Figure 45: Conduit Installation Zone

2.      Support the dock leveler in accordance with the Supporting the Leveler for Maintenance section of the Owner's Manual.

**DO NOT DISCONNECT THE TEMPORARY POWER SUPPLY UNTIL MAINTENANCE STAND IS IN POSITION. DECK WILL AUTOMATICALLY LOWER WHEN POWER IS DISCONNECTED OR PUSH BUTTON IS RELEASED. ONCE MAINTENANCE STAND IS SECURELY IN PLACE, DISCONNECT TEMPORARY POWER SUPPLY.**

### **⚠ DANGER**

**STAY CLEAR OF THE EQUIPMENT'S OPERATING PATH AT ALL TIMES.**

3.      Mount push button in appropriate location. (See “Figure 49: Power Unit and Push Button Location” on page 38)
4.      Remove temporary wire from motor.

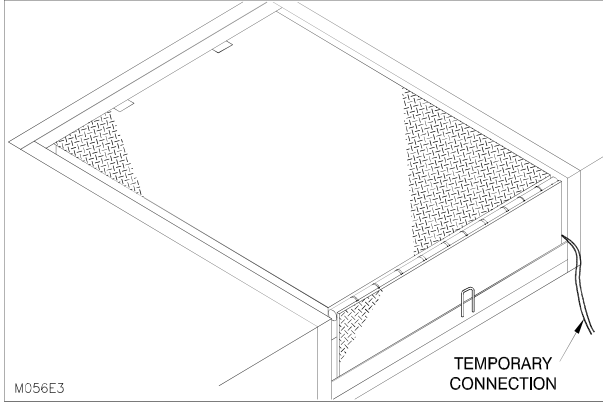

**Figure 47: Accessible Temporary Wire**

5.      Feed electrical line through conduit from push button to power unit and connect as per wiring diagram supplied.
6.      Connect main power supply to push button.

NOTE: Power unit requires full voltage at motor. Wire size should be heavy enough to prevent line voltage drop when motor is under load. (See “ELECTRICAL REFERENCE CHART” on page 39)

7.      Also screw down the jacking screws to remove any potential dead space between the concrete and underside of the pan. (See “Figure 48: Use Jacking Screw to Eliminate Dead Space” on page 37)

**HYDRAULIC DOCK LEVELER WITH REMOTE POWER UNIT:**

1.      Mount both push button and power unit on wall. (See “Figure 49: Power Unit and Push Button Location” on page 38) Mount the power unit horizontally with reservoir breather facing up.
2.      Raise the dock leveler and support according to the section, “SUPPORTING THE LEVELER FOR MAINTENANCE” on page 50.
3.      Feed hydraulic hose through 2” O.D. conduit from inside of pit to power unit.

NOTE: Hydraulic hose is located under dock leveler, and must stay connected to cylinders.

4.      Connect the two (2) hydraulic lines to the Pentalogic hydraulic manifold on the power unit (one hydraulic hose from lip cylinder, and one hydraulic hose from lift cylinder.) See, “Figure 50: Pentalogic Hydraulic Manifold” on page 38.

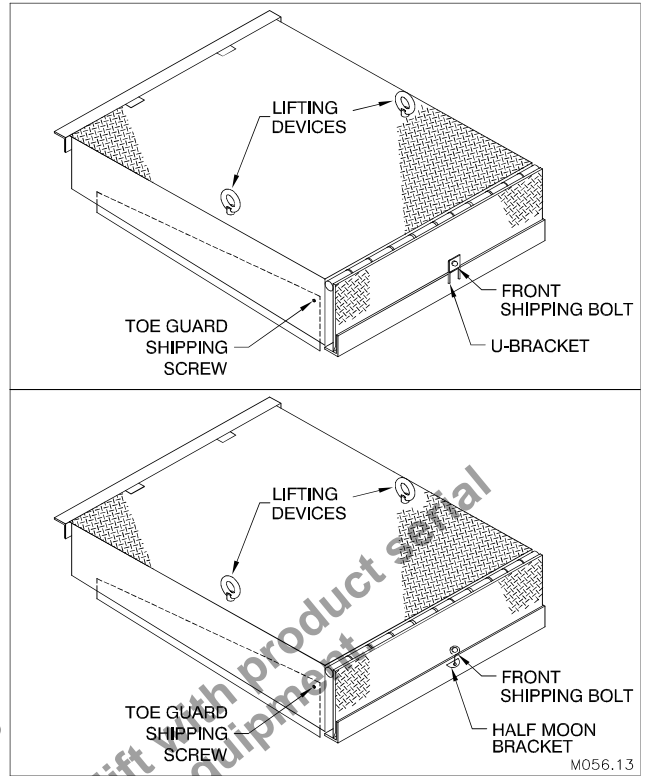

**Figure 46: Shipping Wire, Bolts, and Lifting Devices.**

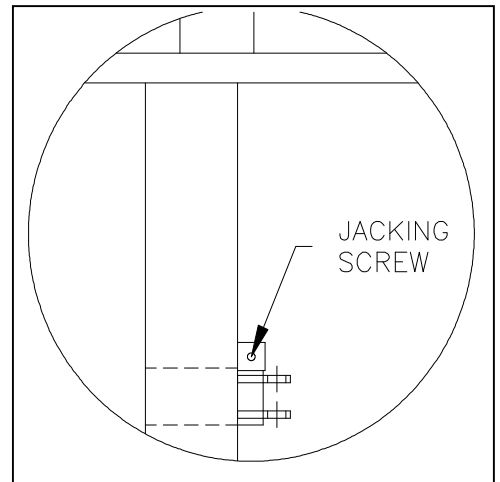

**Figure 48: Use Jacking Screw to Eliminate Dead Space**

5. \_\_\_ Install permanent electrical lines as per applicable electrical diagram provided in control box.

NOTE: Power unit requires full voltage at motor. Wire size should be heavy enough to prevent voltage drop when motor is under load. (See "ELECTRICAL REFERENCE CHART" on page 39)

6. \_\_\_ Also screw down the jacking screws to remove any potential dead space between the concrete and underside of the pan. (See "Figure 48: Use Jacking Screw to Eliminate Dead Space" on page 37)

**⚠ DANGER**

- WIRING MUST BE DONE BY A QUALIFIED ELECTRICIAN.
- ALWAYS USE APPROPRIATE LOCK-OUT PROCEDURES DURING ANY ELECTRICAL INSTALLATIONS.
- ASSURE SUPPLY VOLTAGE IS CORRECT.
- ON 3 PHASE UNITS ASSURE PHASE POLARITY IS CORRECT.
- ALWAYS OBSERVE ALL APPLICABLE ELECTRICAL CODES.

NOTE: The temporary wires supplied are intended to be used for lifting the deck for the initial installation only. Once the maintenance stand is in position, the temporary wires are to be removed from both the power supply and the dock leveler. Permanent wiring must be installed immediately.

**UNITS EQUIPPED WITH AUTO RETURN:**

Run auto return limit switch wire through conduit as shown on applicable pit drawing and hook up in accordance with electrical schematic supplied. See "OPTIONAL AUTO RETURN" on page 44 for Auto Return operation and adjustments.

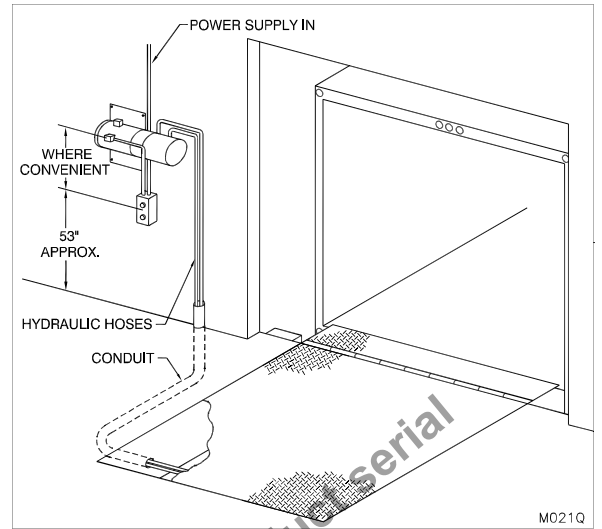

Figure 49: Power Unit and Push Button Location

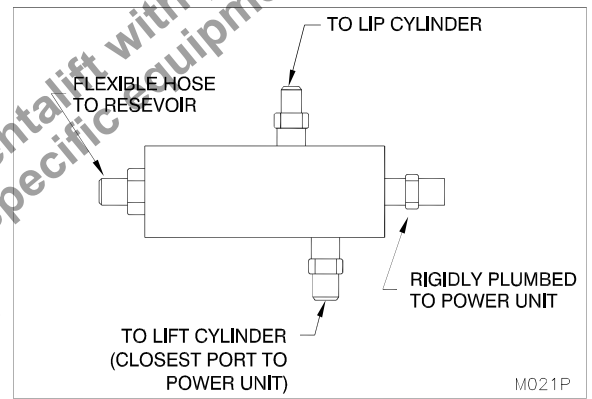

Figure 50: Pentalogic Hydraulic Manifold

\_\_\_\_\_  
Installer Name (Print)

\_\_\_\_\_  
Installer Signature

\_\_\_\_\_  
Date Installation Completed

## ELECTRICAL REFERENCE CHART

<b>ELECTRICAL REFERENCE - 1.5 HP</b>							
	AWG	115/1/60	230/1/60	230/3/60	380/3/50	480/3/60	575/3/60
Length of branch circuit which will have a 2% voltage drop at full load current (copper wire) ft/m.  NOTE: Calculations are based on 30 C Ambient	14		60.3 ft/ 18.4m	168.7 ft/ 51.4m	406.7 ft/ 124m	704 ft/ 214m	1035.1 ft/ 315.5m
	12	38.1ft/ 11.6m	152.5 ft/ 46.5m	268.2 ft/ 81.8m	646.7 ft/ 197.1m	The values given are intended to be a rough wiring guide only.  Be sure to check all applicable electrical codes before wiring.	
	10	60.6 ft/ 18.5m	242.6 ft/ 73.9m	426.8 ft/ 130.1m			
	8	96.4 ft/ 29.4m	385 ft/ 117.5m	678.2 ft/ 206.7m			
	6	153.2 ft/ 46.7m	612.9 ft/ 186.8m				
	Approximate Motor Current (full load) TENV Unit	19 amps	9.5 amps	5.4 amps	3.7 amps		



**FAILURE TO PROPERLY INSTALL ANY PENTALIFT DOCK LEVELER MAY RESULT IN PROPERTY DAMAGE, BODILY INJURY OR DEATH AND WILL VOID ALL WARRANTIES.**

Generic manual for reference only. Contact Pentalift with Pentalift part number to receive owners manual for your specific equipment.

# INSTALLATION PICTURES

Upon completion of installation, photograph the following views as depicted below. Keep photos with owners manual.

1. \_\_\_ Jacking screw(s). (See "Figure 51: Jacking Screw(s)" on page 40)

\_\_\_\_\_  
Installer Name (Print)

\_\_\_\_\_  
Installer Signature

\_\_\_\_\_  
Date Installation Completed

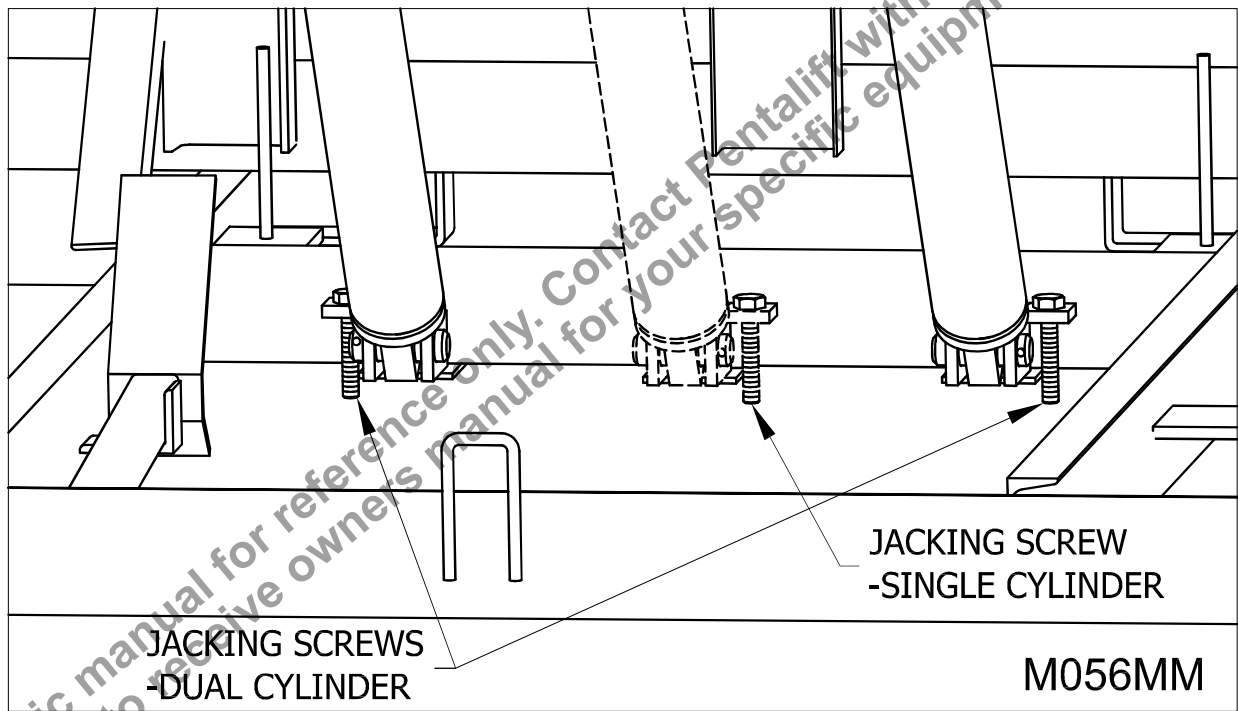

Figure 51: Jacking Screw(s)

# Bumper Installation Guide lines

## LOCATING DOCK BUMPERS DURING INSTALLATION:

1. For the majority of pit type dock leveler installations the dock bumpers are vertically positioned with the top edge of the bumper flush with the top of the loading dock wall face adjacent to top of the dock leveler pit vertical wall. (of the top of where the dock face meets the dock floor.)
2. For the majority of pit type dock leveler installations the dock bumpers are horizontally positioned with the inside edge of the bumper as close to the vertical edge of the dock leveler pit wall as reasonably possible.
3. Note: The word majority is utilized in the above two statements because there maybe exceptions to these rules. The purpose of the dock bumper is to create a designed impact area for approaching truck / trailer traffic. If the above location guidelines would result in locating the bumper such that it will not be properly impacted by the truck and trailers intended to be serviced at the facility, adjustments in positioning and the actual bumper arrangements may be required. Remember that trucks and trailers come in different physical configurations and sizing. The dock bumpers should be positioned to accommodate all the variations that will be serviced. Bumper risers are optionally added to accommodate lower dock heights and 7' or higher trucks. Bumper extensions or projected pits are optionally added to accommodate applications where the normal bumper projection is insufficient such as declined dock approaches. Contact your Pentalift representative for more information or guidelines to suit a specific application.

## Installation methods I.E. Lagging and or welding:

1. Dock bumpers are generally attached in two ways; 1) utilization of concrete lag bolts or 2) welding in position. The use of these two methods depends on the type and configuration of the bumpers selected and the actual installation location.
2. It is quite common for the installation to be a combination of concrete lag bolts and welding.
3. When concrete lag bolts are utilized the dock bumper is usually provided with holes or has a bracket(s) on it with holes to accommodate the lagging. The dock bumper can be moved into the correct final position and used as a template to mark the required hole location for the lag bolts. Lag bolts that accommodate a minimum tensile value of 8710kN and shear value of 12015kN are to be utilized. Confirm the concrete arrangement and composition as well the that bumper hole location provides sufficient concrete material and strength to accommodate the selected lag bolts. Install the lag bolts according to the lag bolt manufacturer's instructions.
4. For welding attachment of bumpers, both the dock bumper and the loading dock area must be designed to accommodate. Typically the bumper will be provided with a flat bar (in place of the bracket with holes). That flat bar will line up with a steel surface that has been located and is suitably anchored into the dock face. Weld the dock bumper flat bar with ¼" welds and 2" stitches a maximum of 4" apart. More weld is better than not enough. Clean and paint the welds after application and cooling.

### DB13 Bumper Typical Installation

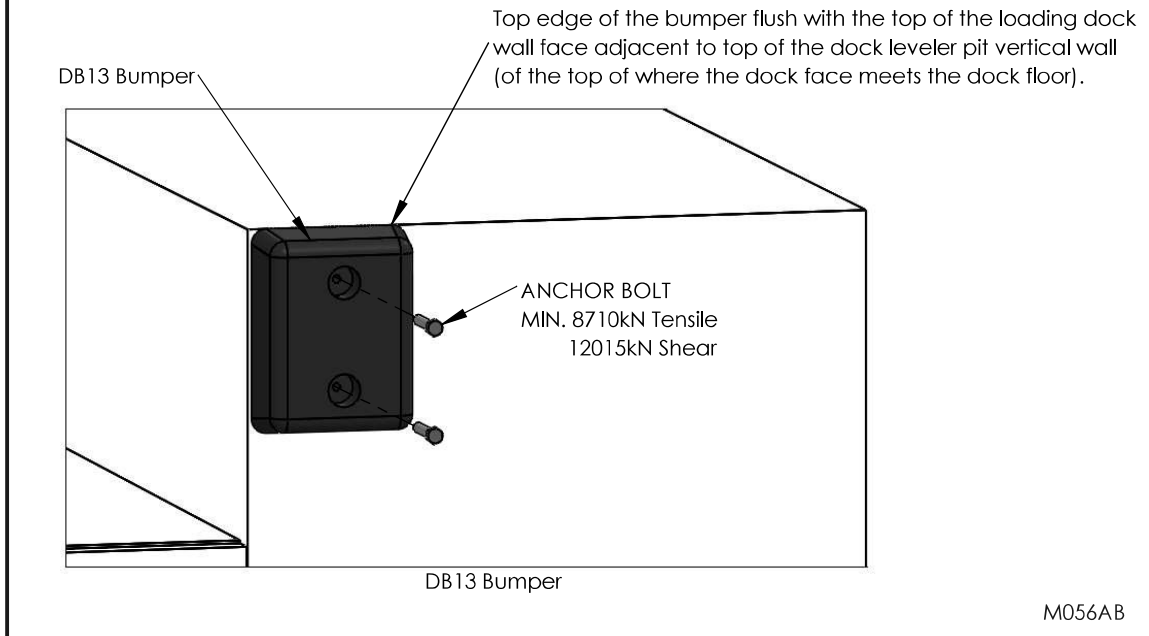

### Bumper Angle Flat-bar Typical Installation

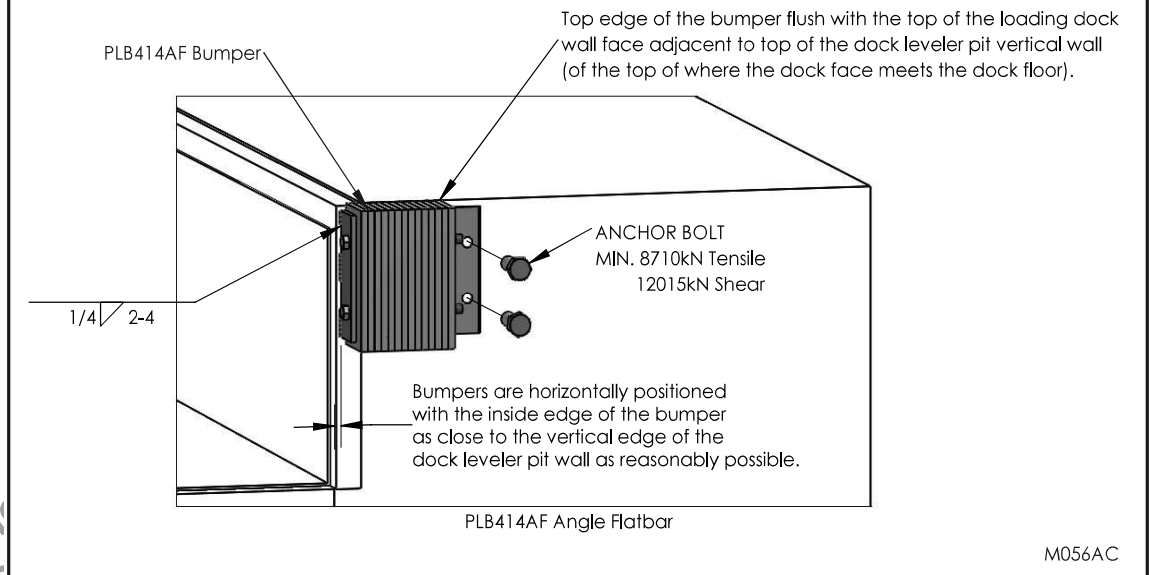

### Bumper Angle Angle Typical Installation

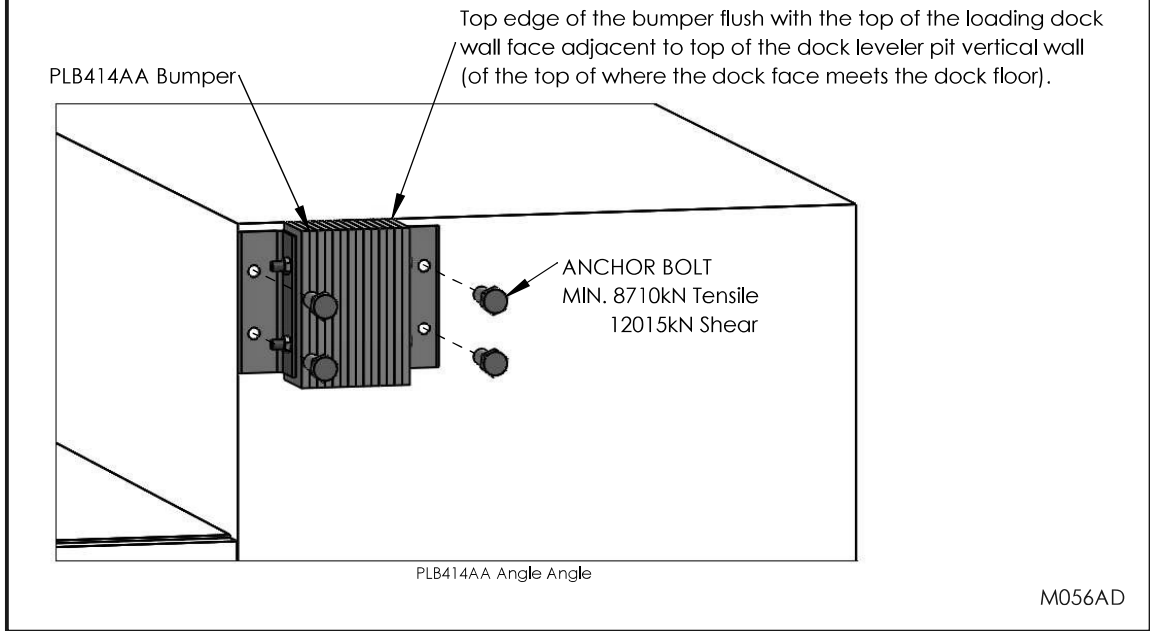

Generic manual for reference only. Contact Pentacorp for more information or call 1-800-333-3333 to receive owners manual for your specific model.

# OPTIONAL AUTO RETURN

## Auto Return Activation



**OPERATION OCCURS ONLY WHEN THE AUTO RETURN SWITCH AT THE CONTROL PANEL IS SET TO THE 'ON' POSITION.**



**MANUAL ACTIVATION OF THE LIMIT SWITCH WILL START THE MOTOR. DISCONNECT POWER BEFORE MAKING ANY ADJUSTMENTS.**

1. The truck departs, causing the deck to descend to the below level stops.
2. As the lip begins to retract, the actuator sleeve attached to the rod on the lip cylinder trips the limit switch. This, in turn, causes the motor to start and the deck to rise, while the lip retracts quickly.
3. This will progress until the lip is fully retracted. At this point the actuator sleeve will no longer trip the limit switch.
4. The limit switch then de-activates the motor and the deck lowers to the stored position.

## Auto Return Adjustment

The auto return requires adjustment if either of the following two conditions occur:

**CONDITION #1:** The lip does not retract enough for the dock leveler to park itself with the lip behind the front angle ("Figure 57: Deck in (Cross Traffic) Stored Position" on page 48) at the stored position.

**ADJUSTMENT #1:** In order to allow the lip to retract further before the motor shuts off, the actuator sleeve must be positioned closer to the rod end of the lip cylinder. Loosen the set screw retaining the actuator sleeve and slide it along the collar assembly rod.

**CONDITION #2:** The dock leveler lip retracts completely but the motor does not shut off.

**ADJUSTMENT #2:** In order to prevent the motor from running when the lip is fully retracted, the actuator sleeve must be positioned further from the rod end of the lip cylinder. Loosen the set screw retaining the sleeve and slide it along the collar assembly rod.

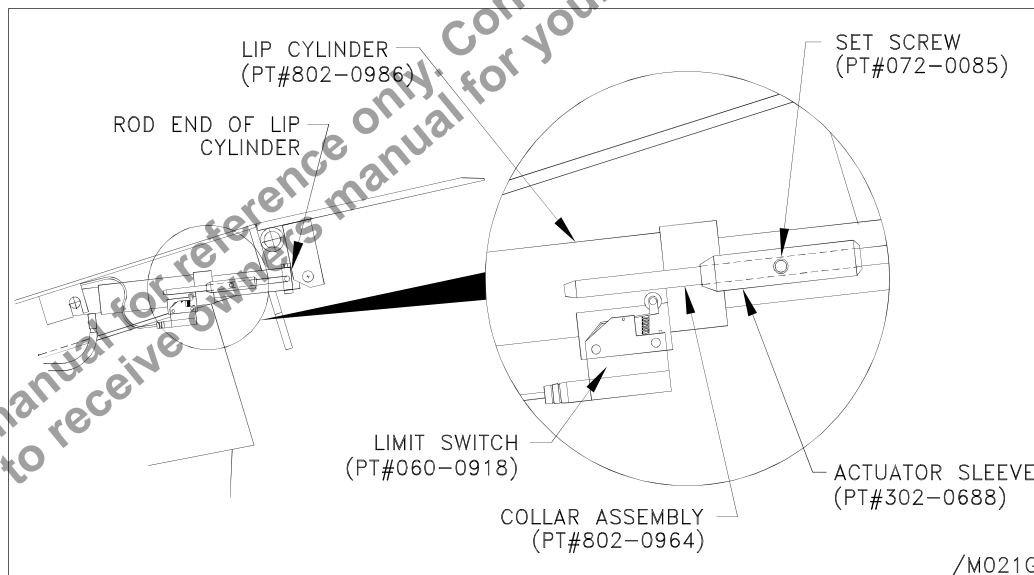

**Figure 55: Auto Return Adjustment**

## Fallsafe Feature

Hydraulic Fallsafe is an emergency support system (incorporating a non-adjustable velocity fuse) that locks the oil in the cylinder, thus preventing the downward movement of the deck. If a fallsafe situation should occur, the dock leveler must be inspected by an authorized Pentalift representative before operation continues. The owner must receive written authorization from Pentalift Equipment Corporation through the authorized Pentalift representative before continuing to use the dock leveler.

## BREAK-IN AND PERFORMANCE CHECK



**BEFORE DOING ANY INSTALLATION, MAINTENANCE INSPECTION OR TROUBLE SHOOTING, BARRICADE ALL AREAS FROM TRAFFIC AROUND THE WORK AREA INSIDE (AND OUTSIDE IF APPLICABLE) FOR SAFETY AND POST APPROPRIATE WARNING SIGNS.**

**NOTE: IN SOME CASES THERE IS A CONSIDERABLE AMOUNT OF TIME BETWEEN THE SHIPMENT DATE AND USE OF YOUR DOCK LEVELER. THIS INITIAL BREAK-IN AND PERFORMANCE CHECK SHOULD BE PERFORMED BEFORE YOU BEGIN REGULAR USE OF YOUR DOCK LEVELER TO ENSURE THAT IT IS OPERATING PROPERLY.**

**NOTE: Read the SAFETY INFORMATION AND WARNINGS before operating the dock leveler. (See page iii)**

**NOTE:** A very high level of field issues with this type of equipment can be directly attributed to improper or incomplete installation. The installation instructions and information provided for this equipment is thorough. A step by step sequence for installation is provided. All steps must be followed and completed to provide a complete installation. Incomplete or improper installations can lead to equipment malfunction and / or damage, create safety issues and void warranties. Please follow all installation and set ups steps as indicated in the installation instructions and owner's manual. If you are unclear or uncertain regarding any of the steps contact your Pentalift representative for clarification. A copy of the completed steps listing with the sign off and photos of the installation as indicated at the conclusion of the installation instructions will be required prior to any Pentalift factory trouble shooting assistance.

1. Ensure that any specified interlocks (e.g. overhead doors, restraints) are fully functional.



**ALWAYS ASSURE NO ONE IS WITHIN 6 FEET OF THE FRONT (LIP END) OF THE DOCK LEVELER PRIOR TO ACTIVATION. STAY CLEAR OF DOCK LEVELER WHEN IT IS MOVING.**

2. Operate the dock leveler several times as described in Operating Instructions.
3. Cycle the dock leveler through all its functions a minimum of ten times. This will remove unwanted air in the hydraulic system.
4. Raise leveler and install maintenance stand as outlined on page 50.
5. Inspect hydraulic system for leaks, especially at fittings and hose connections.
6. Lubricate all pivot points with Dexron III Automatic Transmission Fluid. (See "INSTALLATION, INSPECTION, MAINTENANCE AND LUBRICATION" on page 56)
7. **NOTICE** As the performance test is being conducted, watch closely for any signs that the dock leveler might not be operating properly. If you are in doubt, refer to "OPERATING INSTRUCTIONS" on page 46 and "TROUBLE SHOOTING GUIDE" on page 54 or contact your Pentalift representative.

# OPERATING INSTRUCTIONS

**Note On Capacity:** The dock leveler capacity indicated on the serial plate must be divided with a factor to accommodate dynamic loading factors. For more information see Pentalift document - Dock Leveler Capacity – Understanding Loading Dock Capacity at <http://www.pentalift.com/dock-leveler-capacity.php>

**NOTE:** It is common for this product to be supplied in combination with other Pentalift Products. When the product supplied with other Pentalift products it is quite common for a combination control panel to be provided. The combination control panel will be a single control panel from which more than one product will be controlled and operated. If your installation incorporates the use of such a common control panel then read and follow all the instructions on the panel. If the instructions on the control panel conflict with instructions in this manual then follow the instructions on the control panel.

**Note regarding above and above level ranges of dock levelers relative to dock leveler deck length :**

This dock leveler is designed to accommodate truck and trailer beds that arrive at the facility with heights that are different than the dock height of the facility. The dock leveler deck assembly pivots and rests at angle to accommodate the variance in the truck or trailer bed height. In doing this dock leveler accommodates truck and trailer beds that are both above and below the loading dock floor height.

It is important to manage the extent of this compensation for the difference to a reasonable and desirable level. Factors that determine reasonable and desirable levels include but are not limited to the following:

- The length of the dock leveler deck assembly. The longer the dock leveler deck assembly is the better it will be for accommodating dimensional differences in the truck / trailer bed heights relative to the load dock height. For example, all other conditions being equal, an 8ft long dock leveler deck assembly accommodates a greater height differences than 6ft long dock leveler deck assembly. The longer deck assembly simply reduces the angle of incline that the loading / unloading equipment (IE fork lift or pump truck) have to drive up and down as they go in and out of the truck / trailer.
- The type of loading / unloading equipment being used at the loading dock. For example a gas powered fork lift truck will generally have more power and larger wheels to accommodate larger angles of incline than an electrically powered pallet truck or a manually pushed pallet truck or cart.
- For obvious reasons, larger inclines create more wear and tear on equipment that is powered driven and has brakes.
- Larger inclines can result impact loads applied to the dock leveler as the fork lift hits the inclined dock leveler assembly and this can overload the leveler and result in damage to the dock leveler.
- Large inclines can create safety concerns due to possible run away loads. This is particularly true for manually propelled pump trucks or carts. As well, large inclines can make it onerous to push the same equipment up the inclines.
- Consideration of these factors should be made at the time the loading dock is designed.
- These factors should also be considered whenever changes to the factors listed above change at the loading dock.

**NOTE:** Read the **SAFETY INFORMATION AND WARNINGS** before operating the dock leveler. (See page iii)

## **⚠ DANGER**

USE BY UNTRAINED PEOPLE CAN RESULT IN PROPERTY DAMAGE, BODILY INJURY OR DEATH. READ, KNOW, AND OBEY ALL OPERATING INSTRUCTIONS AND SAFETY INFORMATION. FOLLOW ALL OSHA REGULATIONS REGARDING THE USE OF THIS EQUIPMENT. DO NOT USE THE DOCK LEVELER IF ANY PART OF IT LOOKS BROKEN OR IF IT DOES NOT SEEM TO OPERATE PROPERLY. IF REPAIRS ARE NEEDED, CONTACT YOUR PENTALIFT REPRESENTATIVE.

NOTE: FOR UNITS EQUIPPED WITH A ROLL OFF STOP, STAND CLEAR OF ROLL OFF STOP OPERATING PATH AT ALL TIMES.

## **⚠ DANGER**

TO AVOID POSSIBLE PERSONNEL INJURY AS WELL AS, TO AVOID DAMAGE TO THE DOCK LEVELER AND /OR THE PRODUCT, DO NOT DRAG OR SLIDE ANYTHING ACROSS THE SURFACE OF THE DOCK LEVELER. ALWAYS ENSURE THE FORKLIFT FORKS ARE RAISED TO CLEAR THE DOCK LEVELER SURFACE AND THE DOCK LEVELER COMPONENTS.

### Standard Models:

NOTE: Always be certain that the truck/trailer is parked tight against the face of both dock bumpers and the truck wheels are chocked and/or that the truck is locked in place by a vehicle restraint (See “Figure 56: Minimum 4” Penetration” on page 47) before loading or unloading. All ‘air ride’ trailers must release the air from the suspension mechanism prior to activating the dock leveler for use.

1. Load or unload End Loads with the deck and lip in the stored position as shown in “Figure 57: Deck in (Cross Traffic) Stored Position” on page 48(See “Below Level End Loading” on page 49)
2. Depress and hold the **RAISE** button to raise the deck. The lip will automatically extend at the top of the cycle.
3. Release the **RAISE** button to allow the deck to lower until firm contact is made with the truck bed. **Note:** The lip must extend a minimum of 4” onto the truck bed. (See “Figure 56: Minimum 4” Penetration” on page 47)
4. Proceed to load/unload the vehicle. When completed, return the dock to its stored position by depressing the RAISE button. When the lip is fully retracted and clear of the truck, release the button and the dock will lower into the stored position. Visually inspect the dock leveler to ensure that it is properly stored with the lip inside the front angle. (See “Figure 57: Deck in (Cross Traffic) Stored Position” on page 48)

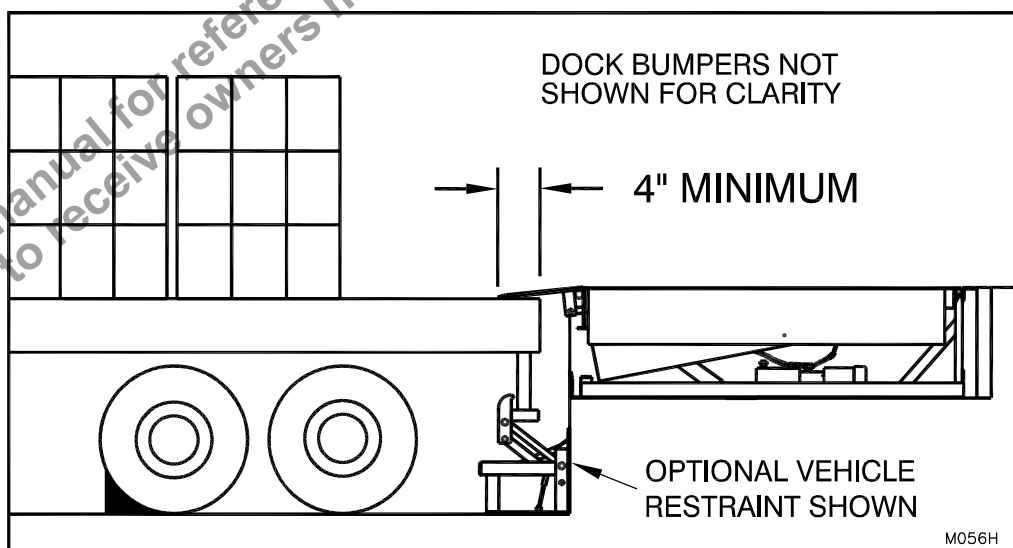

Figure 56: Minimum 4” Penetration

## For Models Equipped with Auto Return:

NOTE: Auto Return is a feature which will cause the dock leveler to automatically return to the stored position in the event that a truck departs prior to the dock leveler being stored manually.

The dock attendant shall return the dock leveler to the stored position. Auto Return should be considered as a BACK-UP system only, as the Auto Return selector switch may be turned to the "OFF" position thus preventing the dock leveler from automatically storing.

It is the responsibility of the dock attendant to ensure that the dock leveler has been returned to the stored position immediately after loading and/or unloading is complete.

1. Turn Auto Return selector switch to "ON."
2. Follow operating instructions as per standard units (See page 46).

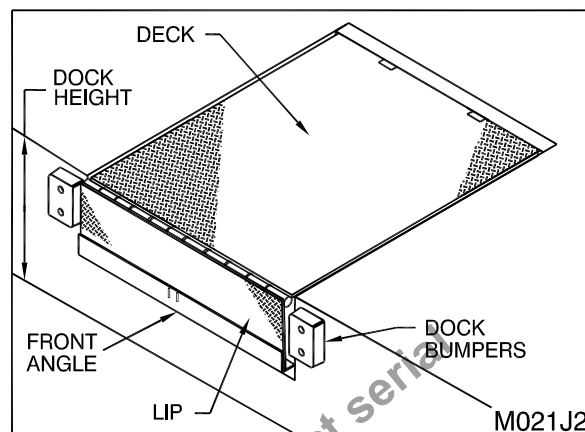

Figure 57: Deck in (Cross Traffic) Stored Position

## For Models Equipped with Deck Stop/ Independent Lip:

### Operating Deck Stop

Note: Units equipped with Deck Stop automatically acquire the Independent Lip feature.

If at any time during the operation of the dock a situation arises requiring the immediate halting of the deck travel (up or down), use the "Deck Stop".

To use Deck Stop:

RELEASE the RAISE button and PRESS AND HOLD the DECK STOP button. When the "Deck Stop" button is released, the deck will be free to lower.



**NEVER USE THE "DECK STOP" BUTTON (if equipped) AS A MEANS OF HOLDING THE DECK UP WHILE PERFORMING MAINTENANCE OR INSPECTION.**

### Operating Independent Lip

Independent Lip Control allows the dock attendant to stop the deck movement and extend the lip prior to the deck reaching the top of its travel.

This function is commonly used to:

- a. Expedite placement of the deck onto the truck bed.
- b. Expedite below level operation.

To use Independent Lip control:

PRESS AND HOLD the **RAISE** button until the deck rises sufficiently to allow the lip to fully clear the truck bed. While continuing to depress the RAISE button, press and hold the **DECK STOP** button. This will halt deck movement and cause the lip to extend. Once the lip is fully extended, release both buttons simultaneously and the extended lip will lower onto the truck.

# END LOADING/UNLOADING



When the cargo at the rear of the truck does not allow the lip to fully extend and rest firmly on the truck bed as outlined under the operating instructions, then the end loading/unloading procedures must be used as outlined under the Operating Instructions. During end loading/unloading there will be a gap present between the dock leveler and the truck bed. Ensure that the front wheels of the fork truck never fall into the gap between the stored dock leveler and the truck. Immediately after the end loads are removed, the dock leveler is to be used with the lip extended as indicated under Operating Instructions.

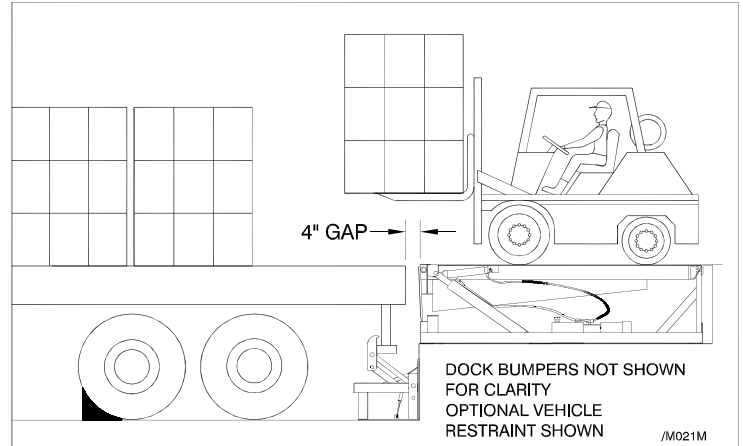

Figure 58: End Loading

## Below Level End Loading

Below level end loading is required when the truck bed is below dock height and the cargo at the rear of the truck does not allow the lip to fully extend. In this instance, end loading/unloading cannot be completed with the leveler in its stored position. To position the leveler for end loading/unloading, follow the procedures outlined below.

## Standard Models

1. Push and hold the RAISE button briefly until the lip begins to extend. The amount of extension is dependent on the cargo and/or truck positioning relative to the leveler.



**ENSURE LIP DOES NOT OVER EXTEND AND DAMAGE FRAGILE CARGO.**

2. Release the raise button and allow the deck to lower onto the deck stops with the lip in the pendant position; outside the front angle (See "Figure 59: Pendant Position" on page 49).

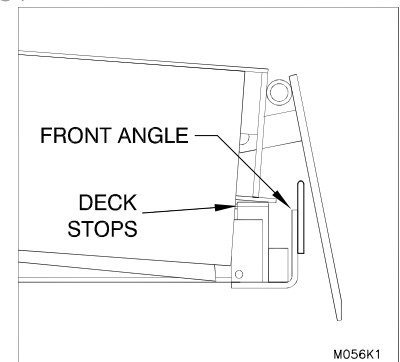

Figure 59: Pendant Position

## Models with Auto Return

1. Turn Auto Return selector switch to "OFF".
2. Follow procedure for standard units.

## Models with Deck Stop/Independent Lip Control

The Deck Stop/Independent Lip function reduces cycle times by allowing the dock attendant to halt deck movement and extend the lip past the front angle without fully cycling the leveler to its top most position.

1. Turn Auto Return (if equipped) selector switch to "OFF".
2. Press and hold the **RAISE** button until the lip (in its pendant position) clears the front angle.
3. While holding the **RAISE** button, jog the **DECK STOP** button until the lip extends slightly beyond the front angle.
4. Release both buttons and allow the deck to lower onto the deck stops with the lip in its pendant position outside of the front angle (See "Figure 59: Pendant Position" on page 49).

## SUPPORTING THE LEVELER FOR MAINTENANCE



Before doing any installation, maintenance, inspection or trouble shooting, barricade all areas from traffic around the work area inside (and outside if applicable) for safety and post appropriate warning signs.



NEVER GO BENEATH THE DOCK LEVELER FOR ANY REASON UNLESS THE DECK AND LIP ARE PROPERLY SUPPORTED AND THE POWER IS DISCONNECTED WITH A FUSED DISCONNECT, PROPERLY TAGGED AND LOCKED OUT. IT IS THE RESPONSIBILITY OF THE OWNER TO ENSURE THAT NO LOAD OR TRAFFIC IS PLACED ON THE DECK WHILE THE MAINTENANCE STAND IS ENGAGED. THE CONSTRUCTION OF THE MAINTENANCE STAND IS INTENDED TO SUPPORT THE WEIGHT OF THE UNLOADED DOCK LEVELER ONLY.



THE BLOCKING PROCEDURES DESCRIBED BELOW ARE SUITABLE ONLY FOR THE INSPECTION, TROUBLE SHOOTING AND MAINTENANCE PROCEDURES DESCRIBED IN THIS MANUAL. THEY MAY NOT BE SAFE FOR OTHER INSPECTION, MAINTENANCE AND REPAIR PROCEDURES THAT MAY BE REQUIRED. CONTACT YOUR AUTHORIZED PENTALIFT REPRESENTATIVE FOR DIRECTION PRIOR TO UNDERTAKING ANY ACTIONS OTHER THAN THOSE DESCRIBED IN THIS MANUAL. FAILURE TO PROPERLY ADHERE TO DECK BLOCKING PROCEDURES IS TO RISK THE SUDDEN AND UNCONTROLLED DESCENT OF THE DECK DURING MAINTENANCE OR INSPECTION. A FALLING DECK CAN CAUSE SEVERE INJURY OR DEATH. IF OTHER TYPES OF REPAIRS ARE REQUIRED, THEN A PENTALIFT AUXILIARY MAINTENANCE STAND IS TO BE UTILIZED. SEE PAGE 52 FOR MORE INFORMATION ON HOW IT IS USED. THE AUXILIARY MAINTENANCE STAND IS AVAILABLE THROUGH THE PENTALIFT PARTS DEPARTMENT. IT IS PENTALIFT PART NUMBER 5000264



The maintenance stand of this dock leveler is designed for use only when the dock leveler is securely welded into the dock leveler pit. Use of the stand is not recommended if the dock leveler is not securely welded into the pit (see “Figure 13: Hydraulic Dock Back Angle Weld of Dock Leveler” on page 12). To support the dock leveler at times when installation welding is not in place, utilize the auxiliary maintenance stand (see “Figure 51.1: Supporting the Dock Leveler with the Auxiliary Maintenance Stand” on page 42) that supports the dock leveler more centered on the dock leveler width.

When performing any maintenance, adjustments, or trouble shooting on the dock leveler, always use the maintenance stand to support the leveler before going beneath the deck.

### FOR HINGED STYLE MAINTENANCE STAND:

Raise the deck to its maximum raised height and fully extend the lip. The hinged style maintenance stand mounts on a mounting bracket. Pivot the maintenance stand up and lower the deck until both the deck and lip are supported by the maintenance stand as shown in the illustration below. If the maintenance stand does not properly support the deck & lip, raise the dock leveler to accommodate repositioning of maintenance stand for proper support.

See “Figure 60: Hinged Style Maintenance Stand” on page 51.

**NOTE: Positioning of maintenance stand will be different in dock leveler with 2 lift cylinders.**

### FOR DROP IN STYLE MAINTENANCE STAND:

Raise the deck to its maximum raised height and fully extend the lip. Lift the maintenance stand out of the cradles and place on the front angle in a position so that it will not interfere with a deck beam. Lower the deck until both the deck and lip are supported by the maintenance stand as shown in the illustration below. If the maintenance stand does not properly support the deck & lip, raise the dock leveler to accommodate repositioning of maintenance stand for proper support.

See “Figure 62: Proper Placement of The Drop in Maintenance Stand” on page 51 for the proper placement of the drop in maintenance stand.

Also follow all safe working procedures and the Safety Instructions as stated in this manual.

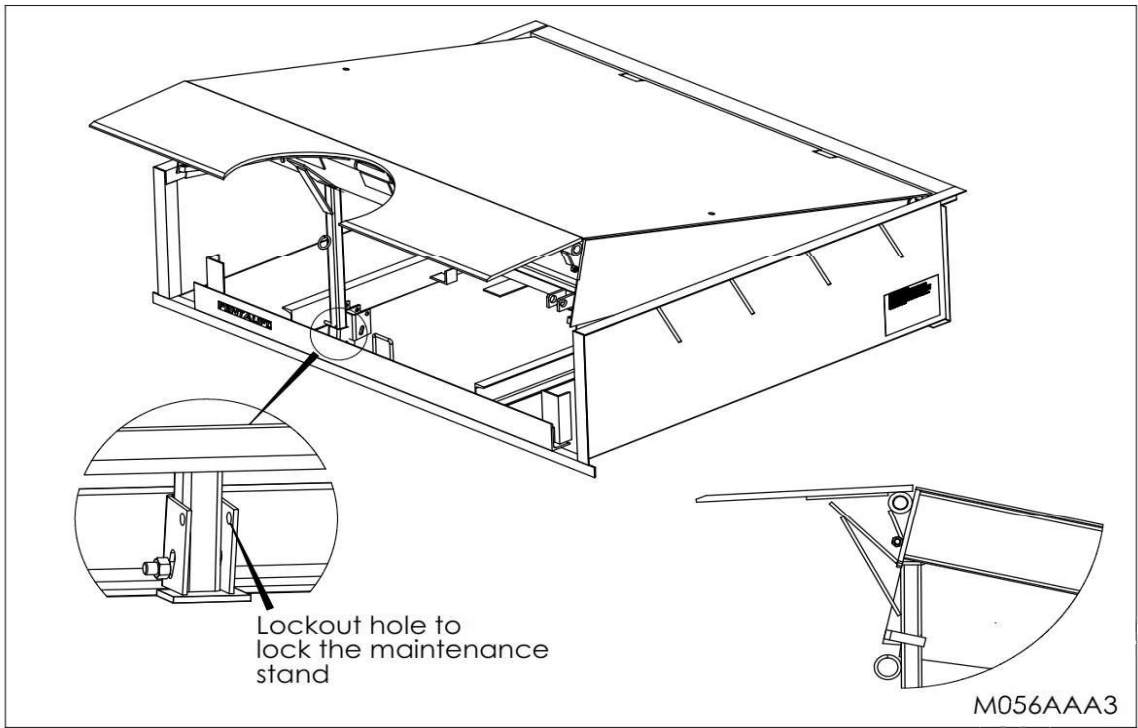

Figure 60: Hinged Style Maintenance Stand

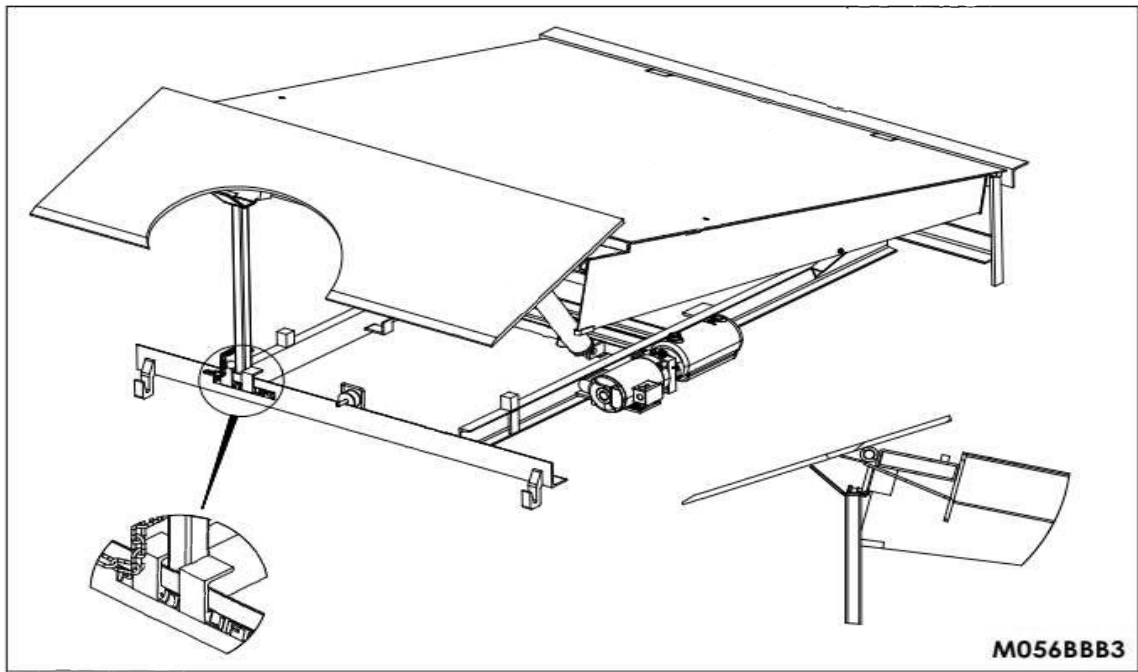

Figure 61: Drop in Style Maintenance Stand for Roll Off Stop Models

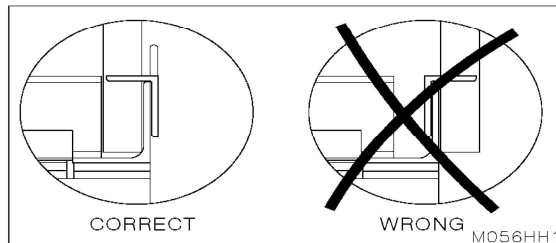
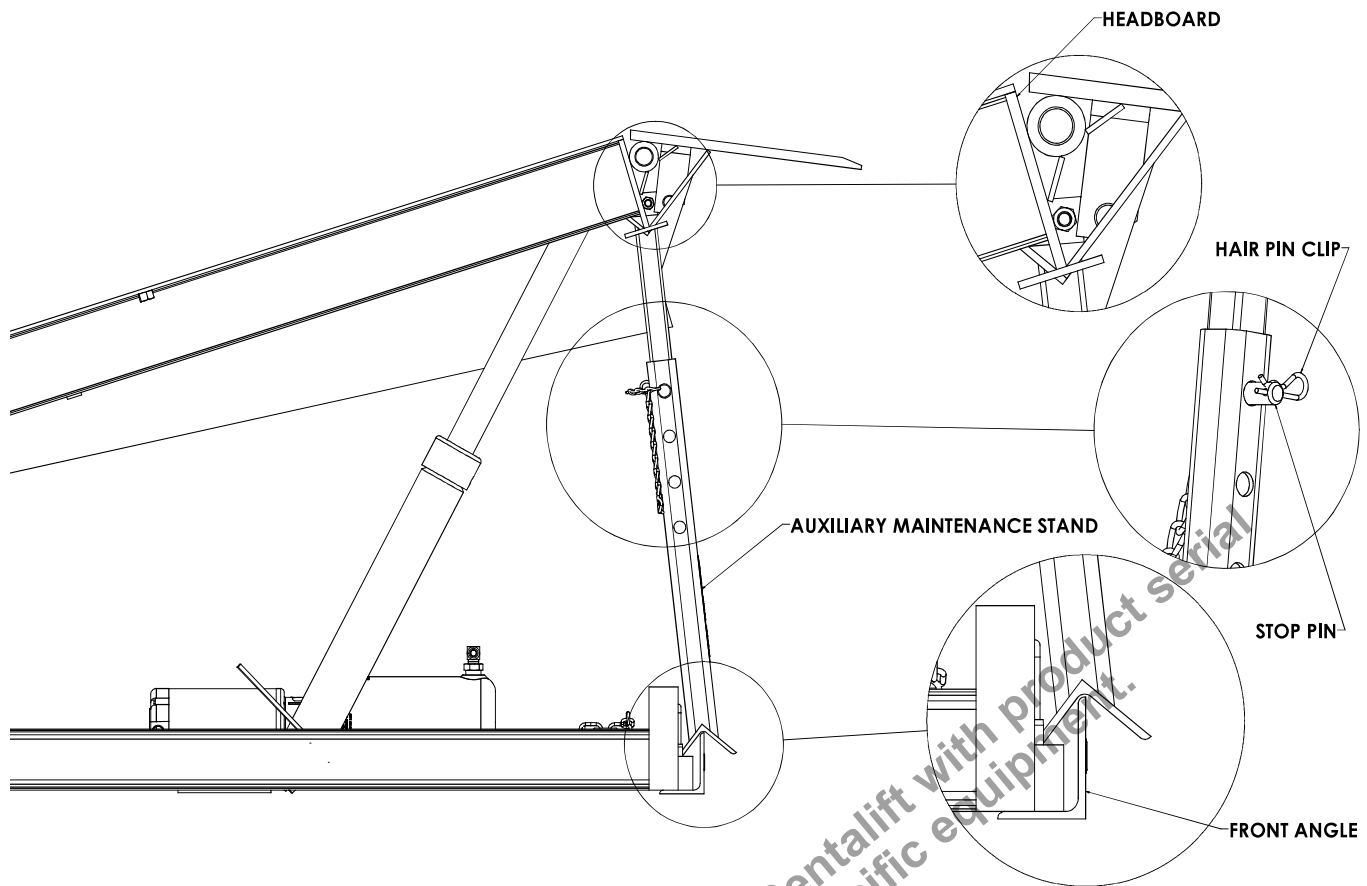

Figure 62: Proper Placement of The Drop in Maintenance Stand



M056Z5

**Figure 62.1: Supporting the Dock Leveler with the Auxiliary Maintenance Stand**

Pentalift auxiliary maintenance stand

The auxiliary maintenance stand is available through the Pentalift part department. It is Pentalift part number 5000264.

The Pentalift auxiliary maintenance stand is to be used whenever there are repairs or maintenance requirements of a more involved or substantial nature. Figure 62.1 on page 52 shows the stand. The stand is telescopic and facilitates its extension or retraction to match the required length for various models of dock leveler. The stand should be used by first engaging the integrated maintenance stand of the dock leveler as described in this manual. Then engage the auxiliary stand by locating the bottom end of the angle bracket on a substantial portion of the lower dock leveller frame. The upper angle bracket is then extended to capture a portion of the dock leveler headboard. The stop pin is utilized to lock the stand in one of the selectable extended positions. Retain the stop pin with the attached hair pin clip. Always make sure the maintenance stands are properly engaged prior to commencing repairs or going into the operating path of the dock leveller. If you are not confident regarding the proper application of the stands do not commence work or go beneath the deck. Figure 62.1 on page 52 shows the proper use and location of the stand.

Note: In some instances it may be best to utilize two auxiliary maintenance stands to support the dock leveler. The two maintenance stands can be spaced equally over the width of the dock leveler

## ADJUSTABLE LIP STOP

The lip stop for all capacities 30,000 through 50,000 lbs is adjustable. The lip stop stops the lip in the correct location when moving the dock leveler into the stored position. The threaded adjustment mechanism consists of a 5/8-11 bolt mounted through the headboard along with two 5/8-11 adjustment nuts.

**NOTE: Proper adjustment is made at the factory and typically won't require further adjustment. Donot attempt any adjustments unless confirmed therwise.**

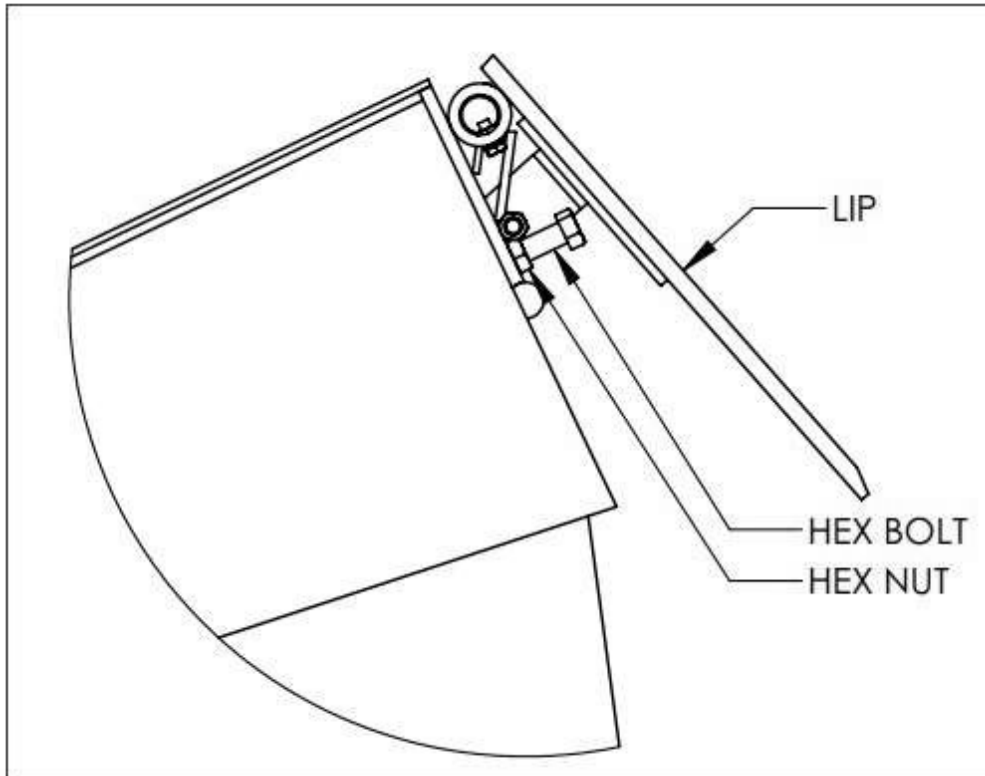

Figure 69: Adjustable Lip Stop

# TROUBLE SHOOTING GUIDE

**NOTE:** This equipment has been fully tested and confirmed to be operational at the factory. Historically, the majority of operating problems are caused by unnecessary tampering by unqualified personnel. To conform to the terms of the Warranty, contact your authorized Pentalift representative if you are having any difficulty with the leveler during the warranty period. Do not risk voiding the warranty by tampering with the equipment.

**NOTE:** A very high level of field issues with this type of equipment can be directly attributed to improper or incomplete installation. The installation instructions and information provided for this equipment is thorough. A step by step sequence for installation is provided. All steps must be followed and completed to provide a complete installation. Incomplete or improper installations can lead to equipment malfunction and / or damage, create safety issues and void warranties. Please follow all installation and set ups steps as indicated in the installation instructions and owner's manual. If you are unclear or uncertain regarding any of the steps contact your Pentalift representative for clarification. A copy of the completed steps listing with the sign off and photos of the installation as indicated at the conclusion of the installation instructions will be required prior to any Pentalift factory trouble shooting assistance.

## **⚠ DANGER**

Before doing any installation, maintenance, inspection or trouble shooting, barricade all areas from traffic around the work area inside (and outside if applicable) for safety and post appropriate warning signs.

## **⚠ DANGER**

BEFORE DOING ANY ELECTRICAL WORK, BE CERTAIN THAT THE POWER IS DISCONNECTED WITH A FUSED DISCONNECT, PROPERLY TAGGED AND LOCKED OUT. FUSED DISCONNECT AND LOCKOUT DEVICE (SUPPLIED AND INSTALLED BY OTHERS) MUST MEET WITH ALL APPLICABLE CODES AND REGULATIONS. ALL ELECTRICAL WORK MUST BE PERFORMED BY A QUALIFIED ELECTRICIAN IN ACCORDANCE WITH ALL APPLICABLE CODES AND REGULATIONS. ALL OTHER REPAIRS SHOULD BE DONE BY A TRAINED AUTHORIZED PENTALIFT REPRESENTATIVE.

## **⚠ DANGER**

NEVER GO BENEATH THE DOCK LEVELER FOR ANY REASON UNLESS THE DECK AND LIP ARE PROPERLY SUPPORTED (SEE "SUPPORTING THE LEVELER FOR MAINTENANCE" on page 50) AND THE POWER IS DISCONNECTED WITH A FUSED DISCONNECT, PROPERLY TAGGED AND LOCKED OUT. IT IS THE RESPONSIBILITY OF THE OWNER TO ENSURE THAT NO LOAD OR TRAFFIC IS PLACED ON THE DECK WHILE THE MAINTENANCE STAND IS ENGAGED. THE CONSTRUCTION OF THE MAINTENANCE STAND IS INTENDED TO SUPPORT THE WEIGHT OF THE UNLOADED DOCK LEVELER ONLY.

## **⚠ DANGER**

Arc flash and shock hazard PPE (personal protection equipment) required. De-energize equipment before working on or inside. Do not open cover without appropriate PPE. Refer to NFPA 70E for PPE requirements. This panel may contain more than one power source. Hazardous voltage will cause severe injury or death.

## **⚠ DANGER**

THE RELIEF VALVE ON THE POWER UNIT IS PRESET AT THE FACTORY. IT IS AN IMPORTANT SAFETY DEVICE. DO NOT ADJUST OR REMOVE THE RELIEF VALVE.

## **NOTICE**

See page 56 for recommended hydraulic oil.

### **1. Motor does not run when push button is engaged.**

- Check circuit breaker or fuses at the main power supply and at the disconnect.
- Models with "Auto return" have an external reset button, all others have an "Auto Reset".
- On some models, a transformer is supplied with the control panel. If the unit has a transformer, check the two (2) primary fuses and one (1) secondary fuse. Replace if required.
- Check the "Overhead Door" limit switch (If equipped) to see it is set & functioning properly.
- Check for loose wires in the control panel.
- Check to ensure all connections made match the wiring diagram (supplied with the control panel).
- If the problem cannot be solved, consult your authorized Pentalift representative.

### **2. Motor runs but deck does not rise.**

- Check for debris or obstruction that may interfere with the operation of any moving part.
- Check for reverse motor rotation.
- If the problem cannot be solved, consult your authorized Pentalift representative.

**3. Deck rises but will not lower.**

- a) If unit is supplied with auto return and the motor is running, turn auto return selector switch to the "OFF" position. If the unit lowers, see 'Auto Return Adjustments' on page.
- b) If the problem can not be solved, a fallsafe situation may have occurred. **DO NOT ATTEMPT** to force the deck down. If a fallsafe situation should occur, the dock leveler must be inspected by an authorized Pentalift representative before operation continues. The owner must receive written authorization from Pentalift Equipment Corporation through the authorized Pentalift representative before continuing to use the dock leveler.

**4. Main breaker or overload relay is tripping.**

- a) Check for a short circuit in the wiring.
- b) Check all wire connections and ensure the unit is wired according to the wiring diagram supplied with the control panel. Check the supply voltage (See chart "**TABLES OF ELECTRICAL PART NUMBERS**" on page 64)
- c) If the problem cannot be solved, consult your authorized Pentalift representative.

**5. Dock leveler will rise but has a bouncing movement.**

- a) Check the hydraulic fluid level. (See page 56.)



**NEVER GO BENEATH THE DOCK LEVELER FOR ANY REASON UNLESS IT IS PROPERLY SUPPORTED. SEE "SUPPORTING THE LEVELER FOR MAINTENANCE" on page 50**

- b) Check the deck assembly for debris or obstruction.
- c) Check to assure the lift cylinder has been supported (See item 7 "Figure 14: Hydraulic Dock Lift Cylinder Shim" on page 12).
- d) If the problem cannot be solved, consult your authorized Pentalift representative.

**6. Deck raises but lip will not extend or lip extends too slowly.**

- a) Check hydraulic fluid level. (See page 56.)



**NEVER GO BENEATH THE DOCK LEVELER FOR ANY REASON UNLESS IT IS PROPERLY SUPPORTED. SEE "SUPPORTING THE LEVELER FOR MAINTENANCE" on page 50**

- b) Check for damage to the lip cylinder and/or pivot pins and brackets.
- c) Check for leakage in the lip cylinder or hydraulic hose feeding the cylinder.
- d) Inspect the lip spools for debris or obstruction and ensure the lip is moving freely.
- e) If the problem cannot be solved, consult your authorized Pentalift representative.

**7. The lip extends before the deck raises.**

- a) Assure the hydraulic hose from the lip and lift cylinders are connected to the Pentalogic Hydraulic Manifold properly (See "Figure 10: Pentalogic Hydraulic Manifold" on page 11).
- b) If the problem cannot be solved, consult your authorized Pentalift representative.

**8. The lip does not retract.**

- a) Check for damage to the lip cylinder and/or pivot pins and brackets.
- b) Inspect the lip spools for debris or obstructions and ensure the lip is moving freely. Lubricate if required.
- c) If the problem cannot be solved, consult your authorized Pentalift representative.

**9. Optional auto return - dock leveler will not recycle to stored position, but leveler is operational.**

- a) Assure auto selector switch is "ON".
- b) Check wire connections and verify wiring.
- c) Check for defective limit switch with volt ohm meter.
- d) Assure auto return is adjusted properly (see Auto Return Adjustment on page 44).
- e) If the problem cannot be solved, consult your authorized Pentalift representative.

If damaged or worn parts are detected upon inspection, replacement must be undertaken **immediately**. **The Dock leveler must not be used until replacement is completed.** Parts are readily available from your Pentalift representative.

# INSTALLATION, INSPECTION, MAINTENANCE AND LUBRICATION

UNLESS OTHERWISE NOTED, THE FOLLOWING MAINTENANCE AND INSPECTION PROCEDURES SHOULD BE CONDUCTED AT A MINIMUM OF EVERY 30 DAYS. INCREASE FREQUENCY FOR MORE SEVERE ENVIRONMENTS.



**Importance of following installation instructions:** A very high level of field issues with this type of equipment can be directly attributed to improper or incomplete installation.

The installation instructions and information provided for this equipment is thorough. A step by step sequence for installation is provided. All steps must be followed and completed to provide a complete installation. Incomplete or improper installations can lead to equipment malfunction and / or damage, create safety issues and void warranties. Please follow all installation and set ups steps as indicated in the installation instructions and owner's manual. If you are unclear or uncertain regarding any of the steps contact your Pentalift representative for clarification. A copy of the completed steps listing with the sign off and photos of the installation as indicated at the conclusion of the installation instructions will be required prior to any Pentalift factory troubleshooting assistance.



**Importance of inspection, monitoring and correcting structural damage:** The deck, lip and frame assemblies of the dock leveler are structurally subjected to loads on going. It is important to regularly visually inspect the dock levelers structurally for signs of damage or wear. Damage could be in the form of distorted, cracked or broken structural members or welds. Areas to review include but are not limited to; lip and headboards tubes, deck beam adhesion to the head board, deck plate and tail board and rear frame attachment to rear curb angle. Any damage or signs of cracking, etc. should be noted and addressed immediately. Immediate attention and action to address issues of this nature generally results in simple repairs. Issues that are left unchecked and / or unaddressed result in significant repairs and even entire replacement as well as a serious critical failure resulting in serious injury or death. If structural issues are detected, use of the equipment is to be discontinued until the appropriate correction or alteration are made. Continued use will result in further damage and potentially dangerous equipment failure. The frequency of reviews should be a maximum of every 30 days. The frequency should be increased for higher frequency and use applications i.e. multiple shifts or high traffic loading docks. For assistance and guidance in evaluating and correcting structural damage, contact your Pentalift representative.



**BEFORE DOING ANY INSTALLATION, MAINTENANCE, INSPECTION OR TROUBLE SHOOTING, BARRICADE ALL AREAS FROM TRAFFIC AROUND THE WORK AREA INSIDE (AND OUTSIDE IF APPLICABLE) FOR SAFETY AND POST APPROPRIATE WARNING SIGNS. NEVER GO BENEATH THE DOCK LEVELER FOR ANY REASON**

**UNLESS THE DECK AND LIP ARE PROPERLY SUPPORTED (SEE "SUPPORTING THE LEVELER FOR MAINTENANCE" on page 50) AND THE POWER IS DISCONNECTED WITH A FUSED DISCONNECT, PROPERLY TAGGED AND LOCKED OUT. IT IS THE RESPONSIBILITY OF THE OWNER TO ENSURE THAT NO LOAD OR TRAFFIC IS PLACED ON THE DECK WHILE THE MAINTENANCE STAND IS ENGAGED. THE CONSTRUCTION OF THE MAINTENANCE STAND IS INTENDED TO SUPPORT THE WEIGHT OF THE UNLOADED DOCK LEVELER ONLY.**



**Arc flash and shock hazard PPE (personal protection equipment) required. De-energize equipment before working on or inside. Do not open cover without appropriate PPE. Refer to NFPA 70E for PPE requirements. This panel may contain more than one power source. Hazardous voltage will cause severe injury or death.**



**THE RELIEF VALVE ON THE POWER UNIT IS PRESET AT THE FACTORY. IT IS AN IMPORTANT SAFETY DEVICE. DO NOT ADJUST OR REMOVE THE RELIEF VALVE.**

**NOTE: Read the SAFETY INFORMATION AND WARNINGS before servicing the dock leveler. (See page ii)**

**NOTE: It is the owner's responsibility to assure that all labeling remains legible and in its original position throughout the life of the product. (See "SAFETY LABELING" on page 3)**

**NOTE: Inspect the equipment for structural damage as detailed on page 56**

**NOTE: Inspect equipment for protective coatings (i.e. paint) that has deteriorated or been removed. Prepare affected area and reapply protective coating as required.**

**NOTE: At every maintenance interval, inspect the Dock Leveler for any damage or worn parts. If any damaged or worn parts are found, discontinue use of the dock leveler and/or repair immediately.**

## Hydraulic Oil:

**Weekly:** Once a week, or after repetitive operation, the cylinder should be extended to its maximum stroke. This will get rid of cylinder oil seepage build-up and lubricate the upper cylinder barrel.

**Monthly:** The recommended lubrication **service interval is every 30 days** or at a greater frequency as required in severe environments. **HVI-22** hydraulic fluid is recommended. (See “Figure 63: Lubrication Points” on page 57 for lubrication points).

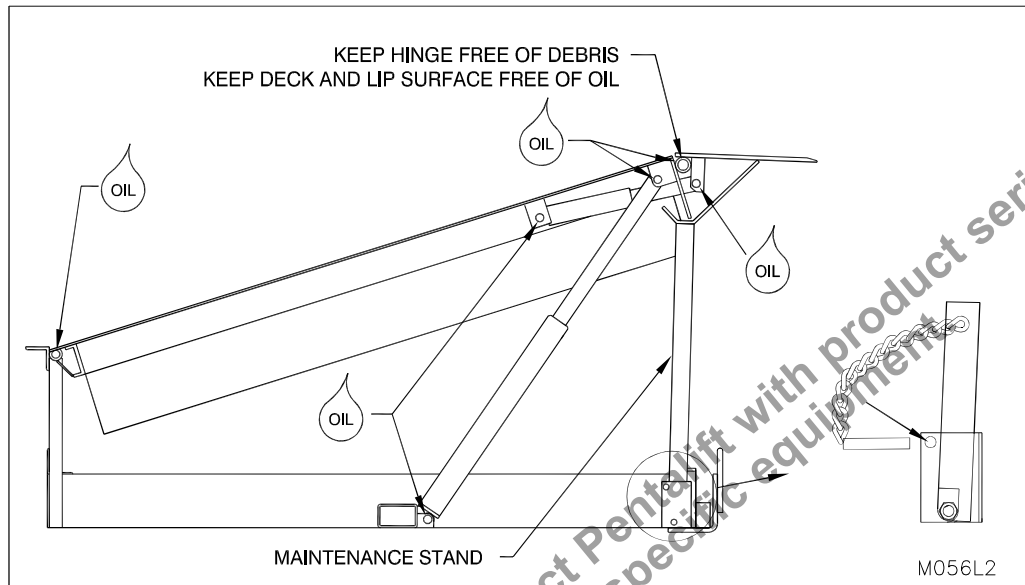

**Figure 63: Lubrication Points**

The oil level should be checked once a month. When the dock leveler is fully lowered, the oil level in the reservoir of a 1 or 3 hp power unit should be approximately 2 – 3 inches from the top. The oil should be changed once a year under normal operating conditions. A maintenance log be maintained with the dates of monthly inspections, the name of the inspector and results of the inspection.

**Seasonal or semiannual maintenance:** Change hydraulic fluid for ambient temperature changes if appropriate. Check the fluid reservoir to see if there is any evidence of accumulated condensation creating water contamination. The fluid will appear “milky” and light pink in color. Water accumulation will damage the hydraulic pump.

### **NOTICE: HYDRAULIC FLUID**

The standard hydraulic oil supplied with the equipment is HVI-22 Hydraulic fluid. This fluid is suitable for use from approximately -30° C (-22F) minimum to +35°C (+95°F) unless otherwise specified on the specific equipment order. The equipment can be operated in temperatures slightly higher and lower than the temperatures stated on an intermittent basis. Operating the equipment for extended periods of times at temperatures higher or lower than the stated temperatures above may result in functional issues for the equipment. It may also result in damage and issues to hydraulic components. As the actual temperature the equipment is used in moves further away from the recommended temperature range the concern points increase. Abuse and overuse in this regard will void all warranty.

The standard replacement Hydraulic Fluid is HVI-22 hydraulic fluid which accommodates the temperature range stated above. There are special hydraulic fluids available to accommodate temperatures that are consistently and or significantly lower or higher than those stated above. In many cases the use of these types of specialty fluids will result in the requirement for hydraulic fluid changes during seasonal yearly temperature changes.

Recommended for colder temperatures is Hydraulic Fluid 5606A  
Recommended for warmer temperatures is Hydraulic Fluid HVI-32

If the hydraulic oil provided from the factory is non-standard, refer to the hydraulic reservoir fluid label which will specify the particular oil requirements.

**Note:** When approaching or operating in temperature beyond the high and low temperature ranges of the ratings for the hydraulic fluids, there may be some adverse effects to the functionality of the equipment. This could include (but not be limited to) harmonics and vibration of cylinders, inhibited or reduced equipment performance and function, slower cycle times, hydraulic leaks unwanted activation of velocity fuses. To address concerns of this nature a change in hydraulic fluid or a special oil additive maybe required. Contact your Pentalift representative for more information.

**Note:** The remote installation location of the hydraulic power unit can also help address concerns with hydraulic fluid temperature ranges. For example if the equipment is purchased with a remote power unit, the power unit can be installed in a warmer (indoor) location. In this arrangement, even though the main equipment and it's hydraulic components maybe exposed to more extreme temperatures, the hydraulic power unit and the hydraulic fluid stored in it will be exposed to and therefore absorb the more moderate and desirable internal temperature. During operation the oil in the power unit will quickly mix with the oil in the equipment and will typically mix to a more desirable temperature level.

**Note:** That if the hydraulic power unit is installed in a pit, as is usually the case for dock levelers, the pit will have moderating effect on the temperature the hydraulic power unit is exposed to. This should be part of the consideration of hydraulic fluid selection.

Generic manual for reference only. Contact Pentalift with product serial number to receive owners manual for your specific equipment.

# REPLACEMENT PARTS

## USE ONLY GENUINE PENTALIFT REPLACEMENT PARTS



To ensure proper functioning, durability and safety of the product, only genuine pentalift replacement parts must be used. Altering the product from its original manufactured configuration must not be done. Pentalift equipment Corporation disclaims all liability for failure to comply with this warning. Warranties are specifically disclaimed in the event the purchaser fails to comply with this warning.

To expedite order processing when ordering parts, provide the following information to your Pentalift representative:

1. Model and Serial Number of equipment.
2. Part Number, Description and Quantity.
3. Shipping Instructions.

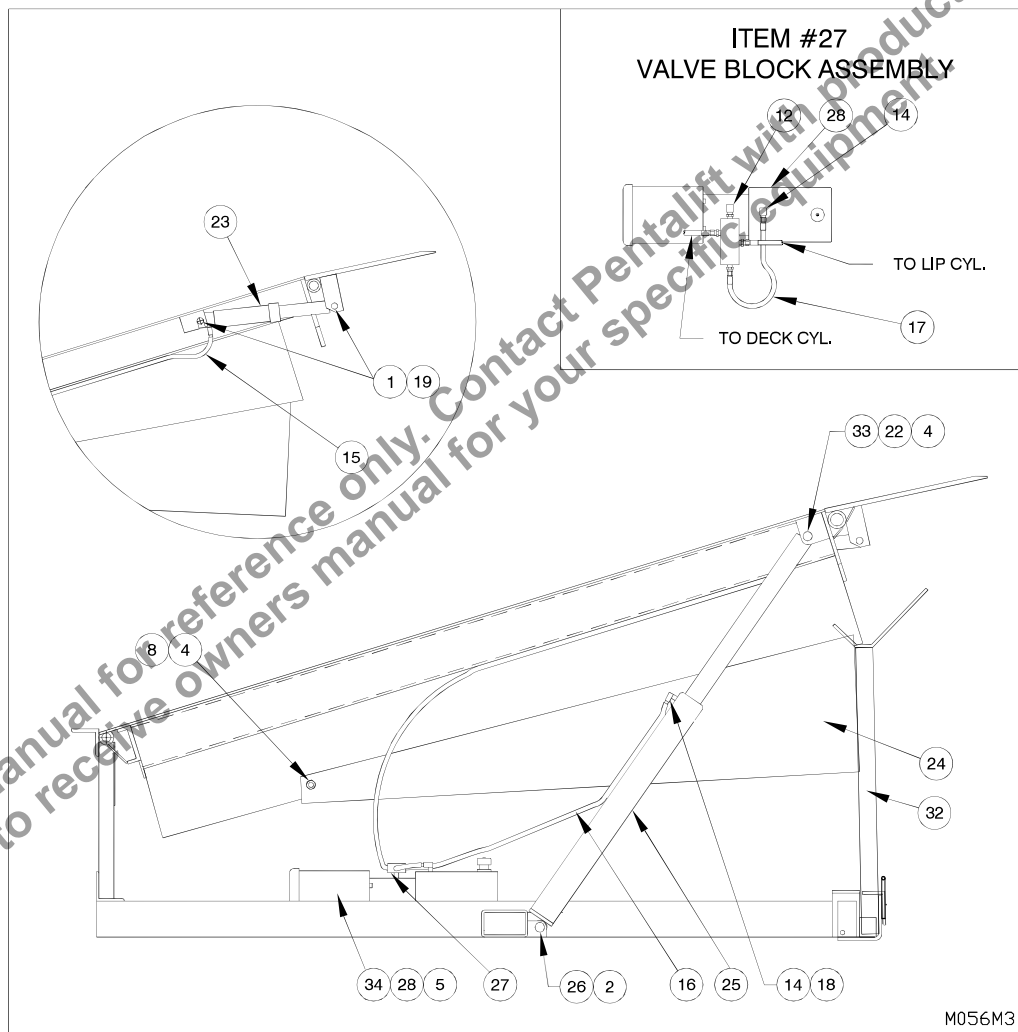

**Figure 64: Replacement Parts**

# REPLACEMENT PARTS (CONT.)

USE ONLY GENUINE PENTALIFT REPLACEMENT PARTS

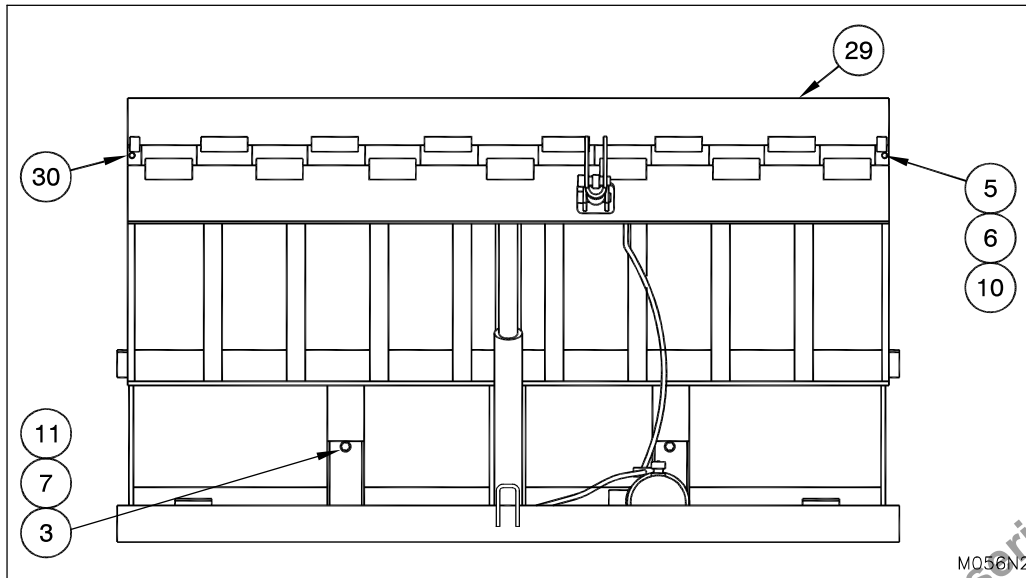

Figure 65: Replacement Parts (Cont.)

Item #	Part No.	Description
1	080-0001	Spring Pin
2	080-0004	Spring Pin
3	074-0080	Lock Washer
4	070-0022	Lock Nut
5	074-0086	Lock Washer
6	072-0018	Hex Head Bolt
7	072-0019	Hex Head Bolt
8	072-0095	Slotted Round Head Bolt
10	070-0013	Hex Nut
11	070-0020	Hex Nut
12	052-0115	90° Street Elbow
14	052-0052	90° Elbow
15	NOTE	Lip Cylinder Hose
16	NOTE	Lift Cylinder Hose
17	NOTE	Return Hose
18	NOTE	Velocity Fuse
19	302-0392	Lip Cylinder Clevis Pin
22	3021522	Lift Cylinder Upper Clevis Pin
23	802-0786	Lip Cylinder
	802-0986	Lip Cylinder (for models with Auto Return)
	802-2841	Lip Cylinder (for models with Roll-Off Stop)
24	NOTE	Side Skirt
25	NOTE	Lift Cylinder
26	802-0892	Lift Cylinder Lower Clevis Pin
27	NOTE	Valve Block Assembly
28	NOTE	Power Unit
29	NOTE	Lip
30	NOTE	Lip Hinge Pin
31	NOTE	Weather Seal
32	500-1501	Maintenance Stand
	500-0337	Maintenance Stand (for models with Roll-Off Stop)
33	072-0148	Hex Head Bolt
34	072-0020	Hex Head Bolt
35	072-0409	Hex Head Bolt (5/8-11x3;gr5;zinc;tap (full thread))
36	070-0021	Hex Nut (nut;hex;5/8-11;gr2;zinc)

**NOTE:** State Model # and Serial # when ordering replacement parts.

**NOTE 2: FOR REPLACEMENT PARTS FOR OPTIONAL AUTO RETURN SEE page 44.**

# CONTROL PANEL REPLACEMENT PARTS

USE ONLY GENUINE PENTALIFT REPLACEMENT PARTS

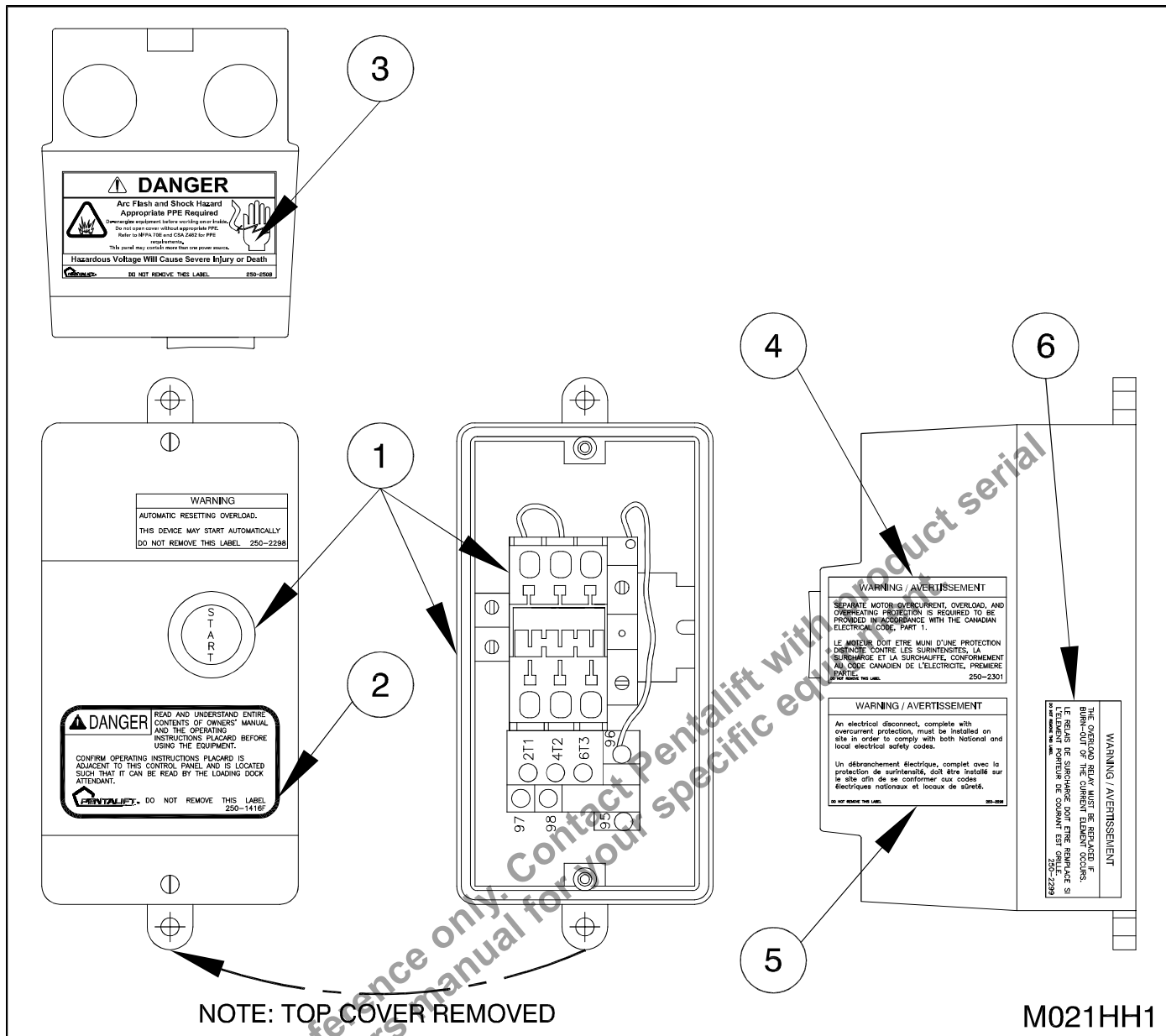

Figure 66: Control Panel - Basic Model (Jog Start)

<u>Item</u>	<u>Part No.</u>	<u>Description</u>
1	060-1077	Pre-assembled Control Panel for 115/1/60
	060-1078	Pre-assembled Control Panel for 230/1/60
	060-1079	Pre-assembled Control Panel for 230/3/60
	060-1081	Pre-assembled Control Panel for 460/3/60
	060-1082	Pre-assembled Control Panel for 575/3/60
2	250-1416	DANGER - Read Owners Manual Contents Label
3	250-2508	DANGER - Arc-Flash & Shock Hazard Decal
4	250-2301	WARNING - Separate motor overcurrent, overload & overheating Decal
5	250-2296	WARNING - Electrical disconnect & overcurrent protection must be installed Decal
6	250-2299	WARNING - Overload relay must be replaced if current element is burned out Decal

**NOTE:** State Model # and Serial # when ordering replacement parts.

# CONTROL PANEL REPLACEMENT PARTS (CONT.)

USE ONLY GENUINE PENTALIFT REPLACEMENT PARTS

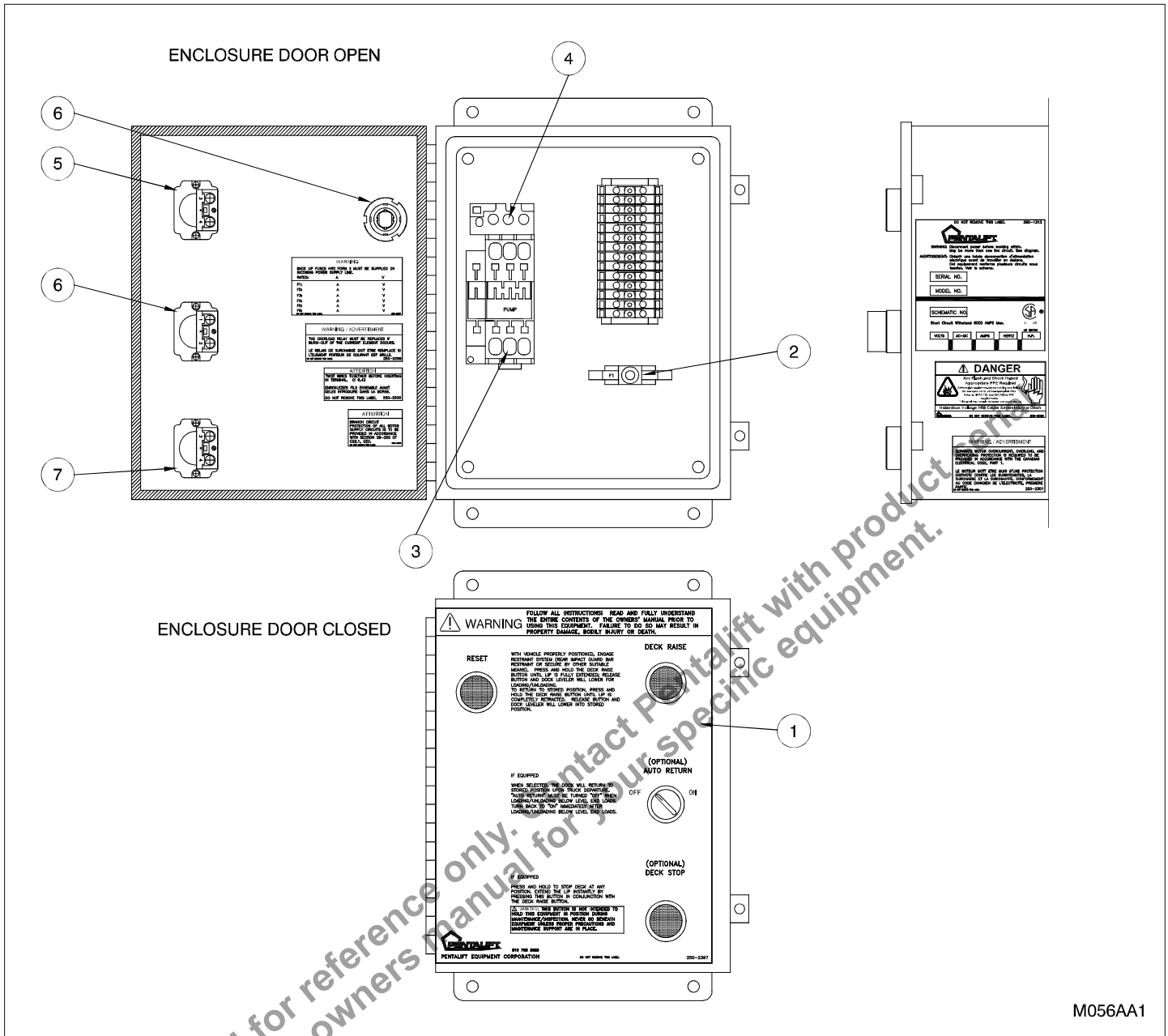

Figure 67: Control Panel - 115V Single Phase Model with Auto Return & /or Deck Stop

Item	Part No.	Description
1	250-2397	Instruction Label
2	060-0541	0.5A / 250V Glass Spiral Wound Fuse
3	060-0184	Contactor
4	060-0067	Thermal Overload
5	161DR	Deck Raise Button
6	161ARRS	Auto Return Switch and Reset
7	161DS	Deck Stop Button

**NOTE:** State Model # and Serial # when ordering replacement parts.

# CONTROL PANEL REPLACEMENT PARTS (CONT.)

USE ONLY GENUINE PENTALIFT REPLACEMENT PARTS

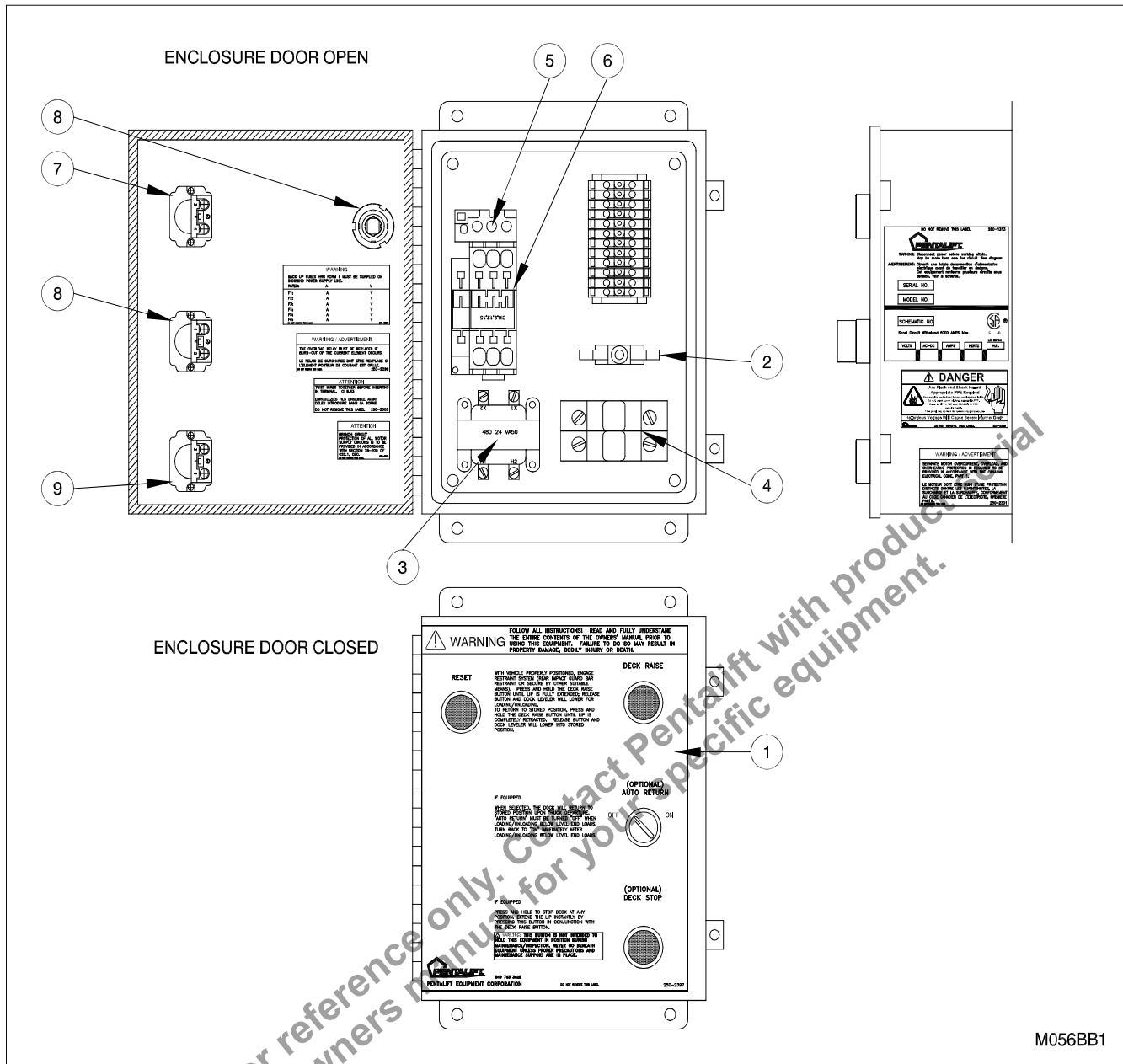

Figure 68: Control Panel - 3 Phase Model with Auto Return & /or Deck Stop

Item	Part No.	Description
1	250-2397	Instruction Label
2	060-0541	0.5A / 250V Glass Spiral Wound Fuse
3	See Chart	Transformer 50VA
4	See Chart	Primary Fuse
5	See Chart	Thermal Overload
6	060-0184	Contactors
7	161DR	Deck Raise Button
8	161ARRS	Auto Return Switch with Reset Button
9	161DS	Deck Stop Button

**NOTE:** State Model # and Serial # when ordering replacement parts.

# TABLES OF ELECTRICAL PART NUMBERS

Fuse I.D.	Single Phase Combo (DL-Restraint)	
	Part No.	Description
F1	060-0537	2 Amp / 250V Fuse
F2	060-0496	7 Amp / 250V Fuse

Fuse I.D.	Three Phase Combo (DL-Restraint)		
	Voltage	Part No.	Description
F1 and F2	575V	060-0024	1/2 Amp / 600V
	460V	060-0024	1/2 Amp / 600V
	230V	060-0300	1 Amp / 600V
F3	575V	060-0537	2 Amp / 250V
	460V	060-0537	2 Amp / 250V
	230V	060-0537	2 Amp / 250V

## TRANSFORMER AND OVERLOAD

Control Box Replacement Parts		
Power Unit Voltage	Part Numbers	
	Transformer	Overload
575 / 3 PH	060-0937	060-1042
460 / 3 PH	060-0937	
230 / 3 PH	060-0943	060-1041
230 / 1 PH	--	060-1040
120 / 1 PH	--	460-1222

**NOTE:** State Model # and Serial # when ordering replacement parts.

# LIST OF ILLUSTRATIONS

Figure 1: Safety Labels and Decals .....	3
Figure 2: Safety Labels and Decals Continued .....	4
Figure 3a: Safety Label and Decal Location - Front Angle .....	6
Figure 3: Safety Label and Decal Location .....	5
Figure 4: Bolt Hole Locations .....	8
Figure 5: Attach Lifting Devices .....	8
Figure 6: Hoist Leveler with Chain .....	9
Figure 7: Accessible Temporary Wire .....	10
Figure 8: Push Button Location .....	11
Figure 9: Power Unit and Push Button .....	11
Figure 10: Pentalogic Hydraulic Manifold .....	11
Figure 11: Hydraulic Dock Front Shims .....	11
Figure 12: Hydraulic Dock Rear Shims .....	12
Figure 13: Hydraulic Dock Back Angle Weld of Dock Leveler .....	12
Figure 14: Hydraulic Dock Lift Cylinder Shim .....	12
Figure 15: Wedging the Rear Frame Angle to the Rear Pit Curb Angle .....	13
Figure 16: Hydraulic Dock Roll-Off Stop Rear Shims .....	13
Figure 17: Hydraulic Dock Roll-Off Stop Front Shims .....	14
Figure 18: Hydraulic Dock Roll-Off Stop Back Angle Weld of Dock Leveler .....	13
Figure 19: Rear Shim Location(4" High Rear Shim Shown) .....	13
Figure 20: Hydraulic Dock Roll-Off Stop Lift Cylinder Shim .....	15
Figure 21: Installing Leveler into Pit .....	16
Figure 22: Rear Shim (4" Shim Kit Shown) .....	16
Figure 23: 30,000 lb + Outer Rear Shims (4" Shim Kit Channel Shim Shown) .....	17
Figure 24: Installation Shims (4" Shim Kit Channel Shim Shown) .....	19
Figure 25: Welding the 3 X 3 Square Tubing to the Curb Angles .....	22
Figure 26: Welding the 4 X 3 Rectangular Tubing to the Curb Angles .....	23
Figure 27: Welding the 4 X 3 Rectangular Tubing to the Curb Angles .....	24
Figure 28: Installing the filler plate .....	24
Figure 29: Welding the 4 X 3 Rectangular Tubing to the Curb Angles .....	25
Figure 30: Installing the filler plate .....	26
Figure 31: Front Angle & Deck Stop Shims .....	28
Figure 32: Thrust Beam Shim(s) .....	28
Figure 33: Rear Shims .....	28
Figure 34: Rear Angle Flush with Curb Angle .....	29
Figure 35: HD Model Curb Angle Force Chart .....	30
Figure 37: Pour-In Pan Components .....	32
Figure 38: Foundation cut out and support pad .....	33
Figure 40: Deck Alignment .....	35
Figure 41A: Shimming 20" Lips .....	35

Figure 41: Shimming 16" & 18" Lips .....	35
Figure 42: Dock Leveler in Position .....	34
Figure 43: One Inch (1") Gap .....	34
Figure 44: Conduits Required .....	36
Figure 45: Conduit Installation Zone .....	36
Figure 46: Shipping Wire, Bolts, and Lifting Devices. ....	37
Figure 47: Accessible Temporary Wire. ....	37
Figure 48: Use Jacking Screw to Eliminate Dead Space .....	37
Figure 49: Power Unit and Push Button Location. ....	38
Figure 50: Pentalogic Hydraulic Manifold .....	38
Figure 51: Jacking Screw(s) .....	40
Figure 55: Auto Return Adjustment .....	44
Figure 56: Minimum 4" Penetration .....	47
Figure 57: Deck in (Cross Traffic) Stored Position .....	48
Figure 58: End Loading .....	49
Figure 59: Pendant Position .....	49
Figure 60: Drop in Maintenance Stand. ....	51
Figure 61: Drop in Maintenance Stand for Roll Off Stop Models. ....	51
Figure 62: Proper Placement of The Drop in Maintenance Stand. ....	51
Figure 63: Lubrication Points .....	55
Figure 64: Replacement Parts .....	57
Figure 65: Replacement Parts (Cont.) .....	58
Figure 66: Control Panel - Basic Model (Jog Start). ....	59
Figure 67: Control Panel - 115V Single Phase Model with Auto Return & /or Deck Stop .....	60
Figure 68: Control Panel - 3 Phase Model with Auto Return & /or Deck Stop .....	61
Figure 69: Adjustable Lip Stop .....	53

Generic manual for reference only. Contact Pentlift with product serial number to receive owners manual for your specific equipment.

# PENTALIFT EQUIPMENT CORPORATION WARRANTY

## WARRANTY

**Pentalift Equipment Corporation** expressly warrants that any product manufactured by **Pentalift Equipment Corporation** will be free from defects in material and workmanship under normal use for a period of one (1) year from the date of shipment of the equipment, provided the original purchaser maintains and operates the product in accordance with proper procedures. In the event the product proves defective in material or workmanship, **Pentalift Equipment Corporation** will at its option:

1. Replace the product or the defective portion thereof without charge to the purchaser; or
2. Alter or repair the product; on site or elsewhere, as **Pentalift Equipment Corporation** may deem advisable, without charge to the purchaser.

The warranty stated in the previous paragraph is that expressed by **PENTALIFT EQUIPMENT CORPORATION** AND IS IN LIEU OF ALL GUARANTEES AND WARRANTIES, EXPRESSED OR IMPLIED BY ANYONE OTHER THAN **PENTALIFT EQUIPMENT CORPORATION**. This warranty does not cover any failure caused by improper installation, misapplication, overloading, abuse, negligence, or failure to lubricate and adjust or maintain the equipment properly and regularly. Parts requiring replacement due to damage resulting from abuse, improper operations, improper or insufficient lubrication, lack of proper protection or vehicle impact are not covered by this warranty. **Pentalift Equipment Corporation** assumes no responsibility or liability for:

1. Consequential damages of any kind which result from use or misuse of the equipment.
2. Damage or failure resulting from the use of unauthorized replacement parts.
3. Damage or failure resulting from modification of the equipment.
4. Damage resulting from the misuse of the equipment.

THERE ARE NO WARRANTIES, EXPRESSED OR IMPLIED, WHICH EXTEND BEYOND THE DESCRIPTION ON THE FACE HEREOF, AND THERE IS NO WARRANTY OF MERCHANTABILITY OR OF FITNESS FOR A PARTICULAR PURPOSE.

**Pentalift Equipment Corporation** warranties extend only to the original product itself. In no event shall **Pentalift Equipment Corporation** be responsible for or liable to anyone, including third parties, for special, indirect, collateral, punitive, incidental or consequential damages, even if **Pentalift Equipment Corporation** has been advised of the possibility of such damages. Such excluded damages include, but are not limited to, loss of good will, loss of profits, loss of use, interruption of business or other similar indirect financial loss.

**Pentalift Equipment Corporation** DISCLAIMS all liability arising out of the workmanship, methods and materials used by the installer.

**Pentalift Equipment Corporation** DISCLAIMS all liability for premature product wear, product failure, property damage or bodily injury arising from improper installation and application.

**Pentalift Equipment Corporation** will not accept any warranty for which the original purchaser does not notify **Pentalift Equipment Corporation's** Warranty Department of the defect within ninety (90) days after the product defect is discovered. A fully completed Product Registration Card is required prior to the review or processing of any warranty requests or claims.

WARRANTIES, whether expressed or implied, relating to workmanship and materials used in connection with the installation of **Pentalift Equipment Corporation** products are specifically DISCLAIMED.

WR001R02



P.O. Box 1510, Buffalo, NY, U.S.A. 14240-1510  
Phone: (519) 763-3625 □ FAX (519) 763-2894  
21 Nicholas Beaver Rd, Puslinch, Ontario, N0B 2J0 Canada  
Phone: (519) 763-3625 □ FAX (519) 763-2894

**NOTE:** All Pentalift Equipment Corporation products are subject to design improvement through modification without notice.