



PENTALIFT EQUIPMENT CORPORATION

DOCK LIFT OWNERS MANUAL

MODEL NUMBER : _____ SERIAL NUMBER : _____

CAPACITY : _____

Individual Model Number(s) and Serial Number(s) must be filled out by the user for future reference.

This manual is an important document.

It shall be kept with the machine or located where readily available to operators and maintenance personnel for reference purposes. Do not install, operate or service this product unless you have read and fully understand the entire contents of this manual. Failure to do so may result in property damage, bodily injury or death. Keep this manual in a safe place for future reference.

**Pentalift Equipment Corporation
21 Nicholas Beaver Rd
Puslinch, ON N0B 2J0
Phone: 519-763-3625
Fax: 519-763-2894
Parts Phone: 519-763-3625 Extension 625
Ask for Parts Department**

Pentalift Equipment Corporation provides an owners manual when equipment is shipped. Additional manuals are available at \$25.00 each

IMPORTANT: The owners manuals that are provided on Pentalift Equipment Corporations website are generic in nature. They are provided for general information only. For all purposes, only the owners manual that is specific to the equipment should be referenced and relied on. In order to receive the specific owners manual for specific Pentalift equipment, please contact your Pentalift representative and supply the specific serial number(s) for the equipment the manual is required for. Do not rely on the information in the generic owners manuals provided through the website as it may not be appropriate for your specific Pentalift equipment.

Generic manual for reference only. Contact Pentalift with product serial number to receive owners manual for your specific equipment.

PRODUCT REGISTRATION

PRODUCT REGISTRATION



PRODUCT REGISTRATION CARD

To validate warranty and to advise of product updates please complete the following information and return to

Pentalift Equipment Corporation

To validate warranty on-line go to: www.pentalift.com

End User Information

*Company Name:		
Contact *First Name:	*Last Name:	Title:
*Mailing Address:		
*City:	*State/Prov.	*Zip/Postal Code:
*Phone: () -	Fax: () -	Email:
Check Products Purchased: <input type="checkbox"/> Levelers, <input type="checkbox"/> Vehicle Restraints, <input type="checkbox"/> Seals/Shelters, <input type="checkbox"/> Elevating Docks, <input type="checkbox"/> Lift Tables		
*Serial Number(s):	Invoice # (if available):	
Dealer Name:	Sales Rep.:	
Manual Verification *Manual Number:		

*Indicates information that must be provided.

Please return to:

Pentalift Equipment Corporation
P.O. Box 1510,
Buffalo, NY 14240-1510

or

Pentalift Equipment Corporation
21 Nicholas Beaver Rd
Puslinch, Ontario N0B 2J0

Attention: Service Department

Or Fax to (519) 763-2894

SAFETY INFORMATION AND WARNINGS



READ THESE SAFETY PRACTICES BEFORE INSTALLING, OPERATING OR SERVICING THE DOCK LIFT. FAILURE TO FOLLOW THESE SAFETY PRACTICES MAY RESULT IN PROPERTY DAMAGE, BODILY INJURY OR DEATH.

THE OPERATION OF THIS EQUIPMENT IS SUBJECT TO CERTAIN HAZARDS THAT CAN BE PROTECTED AGAINST ONLY BY THE EXERCISE OF CARE AND COMMON SENSE AND NOT BY MECHANICAL MEANS. IT IS, THEREFORE, ESSENTIAL TO HAVE COMPETENT, QUALIFIED OPERATORS TRAINED IN THE SAFE OPERATION AND CARE OF THIS TYPE OF EQUIPMENT. ALL PERSONNEL MUST COMPLETELY UNDERSTAND THIS SAFETY INFORMATION BEFORE WORKING ON OR NEAR THIS EQUIPMENT.



DANGER indicates an imminently hazardous situation which, if not avoided, will result in death or serious injury.



WARNING indicates a potentially hazardous situation which, if not avoided, could result in death or serious injury.



CAUTION, used with the safety alert symbol, indicates a potentially hazardous situation which, if not avoided, could result in minor or moderate injury.



NOTICE is used to address practices not related to personal injury.



Before doing any installation, maintenance, inspection or trouble shooting, barricade all areas from traffic around the work area inside (and outside if applicable) for safety and post appropriate warning signs.



Arc flash and shock hazard PPE (personal protection equipment) required. De-energize equipment before working on or inside. Do not open cover without appropriate PPE. Refer to NFPA 70E for PPE requirements. This panel may contain more than one power source. Hazardous voltage will cause severe injury or death.



Before doing any electrical work, be certain that the power is disconnected with a fused disconnect, properly tagged and locked out. Fused disconnect and lockout device (supplied and installed by others) must meet with all applicable codes and regulations. All electrical work must be performed by a qualified electrician in accordance with all applicable codes and regulations.



NEVER GO BENEATH THE DOCK LIFT FOR ANY REASON UNLESS THE PLATFORM AND HINGED BRIDGE(S) ARE PROPERLY SUPPORTED (SEE "Figure 17: How to Support the Dock Lift for Maintenance" on page 32) AND THE POWER IS DISCONNECTED, PROPERLY TAGGED AND LOCKED OUT. IT IS THE RESPONSIBILITY OF THE OWNER TO ENSURE THAT NO LOAD OR TRAFFIC IS PLACED ON THE PLATFORM WHILE THE MAINTENANCE STAND IS ENGAGED. THE CONSTRUCTION OF THE MAINTENANCE STAND IS INTENDED TO SUPPORT THE WEIGHT OF THE UNLOADED DOCK LIFT ONLY.



It is the responsibility of others to ensure the proper mounting of any wall mounted equipment such as remote power units, control panels and light packages and to ensure that the mounting surface is capable of fully supporting the loads generated by the equipment.

1. Before loading/unloading the truck, ensure the trailer is in position firmly against both of the dock bumpers or bollards and **CHOCK THE TRUCK WHEELS** to eliminate the possibility of the truck rolling or inching forward.
2. NEVER EXCEED THE MAXIMUM RATED CAPACITY OF THE DOCK LIFT. (i.e. The maximum load for a 6,000 lb. rated unit is 6,000 lb. with the load center at the center of the platform.) The single axle load capacity across the ends is 75% of the rated capacity. The single axle load across the sides is 50% of the rated capacity. Refer to the specification plate (See "Figure 2: Safety Label and Decal Locations" on page 3) for each dock lift's particular rating.

3. Never stand between the dock and a truck.
4. Return the dock lift to the stored position before allowing truck to depart.
5. When not in use, the unit MUST be in the fully lowered position.
6. Dock lifts must be lagged to the floor.
7. Do not apply shock loads to the unit. (I.e. Do not drop loads onto the platform, lower loads onto the platform at a high rate of speed, stop unit abruptly or jog in lower range of travel.)
8. The platform surface must be kept clean and free from oil, debris, etc. Keep debris, etc. from underneath the unit.
9. Keep any obstructions and personnel clear of the dock lift and load and their operating path to eliminate injury and/or damage. Avoid or eliminate any and all potential pinch points.
10. Prior to each use, ensure dock lift and load does not create pinch points during operation when located adjacent to or near other equipment or structures.
11. Anyone using or in the vicinity of this equipment must wear protective footwear with steel toes.
12. Never use the unit for raising personnel unless it has been suitably designed and manufactured for that purpose by Pentalift Equipment Corporation. Guard rails and access chains must be used.
13. It is the owner's responsibility to ensure protection is provided for the operator (i.e. access chains) to prevent falling off of the dock lift when the unit is above ground/floor level.
14. All electrical, hydraulic and/or pneumatic lines must be carefully routed to prevent them from being pinched or severed.
15. Regular inspection and maintenance must be performed to keep the equipment in proper operating condition. Pay particularly close attention to all hoses and/or wires in order to detect possible cracks or wear. Always follow the instructions as per the 'HOW TO SUPPORT THE DOCK LIFT DURING ROUTINE MAINTENANCE AND INSPECTION' section in this manual (See page 32) prior to performing any activity within the operating path of the dock lift.
16. HYDRAULIC FALLSAFE: The basic purpose of the fallsafe feature (velocity fuse) is to arrest the platform's downward movement in the event of ruptured or severed hose. If a fallsafe situation should occur, the dock lift must be inspected by an authorized Pentalift Representative before continuing to use the dock lift. The owner must receive written authorization from Pentalift Equipment Corporation through the authorized Pentalift representative before continuing to use the dock lift.
17. Ensure that the Owner's Manual is at all times accessible to anyone who may require it.
18. Ensure that the equipment is not used by anyone if you believe that any part of it might be in disrepair (e.g. loose wires, leaking hoses, bent structural members, broken welds, etc.). See Warranty Section.
19. Do not operate, use, maintain or install this equipment if you are impaired in any manner.
20. If you have any questions, contact your immediate supervisor or your authorized Pentalift representative for assistance.

OWNER RESPONSIBILITY

The Owner's Responsibilities include the following:

1. The owner should recognize the inherent danger of the interface between dock and transport vehicle. The Owner must, therefore, train and instruct operators in the safe use of dock levelling devices.
2. When a transport vehicle is positioned as closely as practicable to a dock levelling device, there shall be at least 4" (100 mm) of overlap between the front edge of the Hinged Bridge and the edge of the floor or sill of the transport vehicle.
3. Nameplates, cautions, instructions and posted warnings shall not be obscured from the view of operating or maintenance personnel for whom such warnings are intended.
4. Manufacturer's recommended periodic maintenance and inspection procedures in effect at date of shipment shall be followed, and written records of performance of these procedures should be kept.
5. **Removal from Service:** Any lift not in safe operating condition such as, but not limited to excessive leakage, missing rollers, pins or fasteners, any bent or cracked structural members, cut or frayed electric, hydraulic or air lines, damaged or malfunctioning controls or safety devices, etc. shall be removed from service until it is repaired to Pentalift Equipment Corporation's standards.
6. **Pentalift Equipment Corporation** shall supply replacement nameplates, caution or instruction labels and operating and maintenance manuals upon request of the owner. The owner shall see that all nameplates and caution and instruction markings or labels are in place and legible and that the appropriate operating and maintenance manuals are provided to users.
7. Modifications or alterations of dock levelling devices shall be made only with written permission of **Pentalift Equipment Corporation**. Alteration permission must be signed by both the Pentalift Post Sale Customer Service Manager and the President to be valid.
8. When industrial trucks are driven on and off transport vehicles during the loading and unloading operation, the brakes on the transport vehicle shall be applied and wheel chocks or positive restraints that provide the equivalent protection of wheel chocks engaged.

NOTE: It is recognized that these devices are intended to secure a transport vehicle to a loading dock by mechanical means. However, no standards currently exist for the strength, construction or attachment of the under ride guard on a transport vehicle. It is therefore recommended that users of such positive restraint devices review:

- The means of attachment to the transport vehicle
- The strength of the overall connection
- The proper coordination of the actuation of devices with any signalling system used
- The need to use wheel chocks

9. In selecting dock levelling devices, it is important to consider not only present requirements, but also future plans or adverse environments.



Unless specifically agreed to in writing by Pentalift Equipment Corporation at the time the equipment is ordered and prior to the equipment's manufacture, this equipment is sold as a complete package. It is not to be altered, changed or added to in any way or form, in its configuration and function, without the written permission of Pentalift Equipment Corporation.

If requested by a customer, Pentalift Equipment Corporation is not supplying all or some of the power unit and / or control components for the equipment's application. The power unit and controls constitute important safety and functional aspects of the equipment. It is the customer's responsibility to address the operational and safety issues associated with providing the required controls and power units to satisfy the operational and safety requirements of the equipment.

The customer's decision to supply all or some of these components indicates that the customer is taking full responsibility for any and all possible operational, safety and liability issues associated to the product and its configuration. The customer also agrees to absolve Pentalift Equipment Corporation from any and all possible operation, safety and liability issues.

EXPLANATION OF CALIFORNIA'S PROPOSITION 65

The product(s) reference by this manual comply with California's Proposition 65 (Prop 65).

Prop 65 is a voter initiative passed in 1986. This law regulates substances officially listed by California as having a 1 in 100,000 chance of causing cancer over a 70-year period or birth defects or other reproductive harm in two ways. The first statutory requirement of Prop 65 prohibits businesses from knowingly discharging listed substances into drinking water sources, or onto land where the substances can pass into drinking water sources. The second prohibits businesses from knowingly exposing individuals to listed substances without providing a clear and reasonable warning. There are several states that regulate or list similar substances. The chemicals do not need to be in liquid form; the consumer only needs to be exposed to them at certain levels.

On August 30, 2016 California adopted amendments to the regulations that govern clear and reasonable warnings under Prop 65. The new regulation took effect August 30, 2018.

A warning label is required which permits our products to be used in California after August 30, 2018. The label need only be in English language. The label meets the guidelines of ANSI Z535.4 which we follow. There is one size (1" h x 2 1/2" w) for all products. It is placed in the proximity of other precautionary labels. A minimum of one label per machine. Proving every listed chemical present would result in levels (micro-grams/day) below the Prop 65 requirement is impractical. To avoid the complication for having labels which are specific to the most prevalent chemical in each unique model the truncated label is acceptable under the California law. In order to use the truncated label, the label must be on the product.



This is the warning label which meets the Prop 65 requirements..

This abbreviated label can also be used for the pre-sale notification. For this responsibility to the law advice is added to our terms and conditions of sale. The owner's manual also supports the notification using this notice:

Additional detail about Prop 65 is available at <https://www.p65warnings.ca.gov/>

TABLE OF CONTENTS

PRODUCT REGISTRATION	I
SAFETY INFORMATION AND WARNINGS.....	II
OWNER RESPONSIBILITY.....	IV
EXPLANATION OF CALIFORNIA'S PROPOSITION 65	V
TABLE OF CONTENTS	1
SAFETY LABELING.....	2
INSTALLATION INSTRUCTIONS	5
ELECTRICAL REFERENCE - 1 HP	9
ELECTRICAL REFERENCE - 1.5 HP	9
ELECTRICAL REFERENCE - 3 HP	10
ELECTRICAL REFERENCE - 5 HP	10
ELECTRICAL REFERENCE - 7.5 HP	11
ELECTRICAL REFERENCE - 10 HP	11
THREE SIDED PIT INSTALLATION.....	16
UP TRAVEL LIMIT SWITCH INSTALLATION (OPTIONAL).....	18
HINGED BRIDGE LIFT ASSIST(OPTIONAL).....	21
NIGHT LOCKS (OPTIONAL)	26
BREAK-IN AND PERFORMANCE CHECK.....	29
OPERATING INSTRUCTIONS.....	30
HOW TO SUPPORT THE DOCK LIFT DURING ROUTINE MAINTENANCE AND INSPECTION	32
MAINTENANCE AND LUBRICATION	33
TROUBLE SHOOTING GUIDE	37
REPLACEMENT PARTS	39
REPLACEMENT PARTS LIST	40
LIFT CYLINDER REPLACEMENT PARTS.....	42
LIST OF ILLUSTRATIONS.....	43
PENTALIFT EQUIPMENT CORPORATION WARRANTY.....	44

Generic manual for reference only. Contact Pentalift with product serial number to receive owners manual for your specific equipment.

SAFETY LABELING

1 **WARNING**
FRAME MUST BE LAGGED TO FLOOR BEFORE OPERATING
DO NOT REMOVE THIS LABEL 250-1358

2 **DANGER**
To avoid bodily injury, stand clear while lift table is moving.
250-10-8 Do not remove this label

3 **WARNING** READ AND UNDERSTAND THE ENTIRE OWNERS MANUAL PRIOR TO INSTALLING, OPERATING, SERVICING OR MODIFYING THIS EQUIPMENT.
DO NOT REMOVE THIS LABEL
MODEL: _____
SERIAL: _____
CAPACITY: _____
SIDE AXLE LOAD CAPACITY (lb) _____
END AXLE LOAD CAPACITY (lb) _____
NOTE: CONTROLS SUPPLIED ARE FOR USE WITH THIS SERIAL NUMBER ONLY. SEE OWNERS MANUAL FOR DEFINITION OF SIDE AND END AXLE LOAD CAPACITY.
MADE IN CANADA 1-(819)-763-3825 WWW.PENTALIFT.COM 250-1358

4 **MAX.**
DO NOT REMOVE THIS LABEL

5 **INSPECTION**
DATE: ____/____/____
INSPECTED BY: _____

6 **WARNING**
PENTALIFT
DO NOT EXCEED RATINGS
DO NOT REMOVE THIS LABEL

7 **LIFT 1 DOCK ONLY (WITH NO LOAD ON IT)**
FORKS HERE
DO NOT REMOVE THIS LABEL 250-1127

8 **CAUTION**
THIS EQUIPMENT HAS BEEN BOLTED CLOSED FOR SHIPPING. REMOVE ALL SHIPPING BOLTS BEFORE OPERATING.
250-1128

9 **WARNING**
Do NOT operate without personnel guarding. Serious injury or death could occur.
Do not remove this label 250-7010

10 **DANGER**
Crush and fall hazards
Read and understand all instructions before operating or servicing lift.
Do NOT enter under this platform unless it is mechanically locked.

Figure 1: Safety Labels and Decals

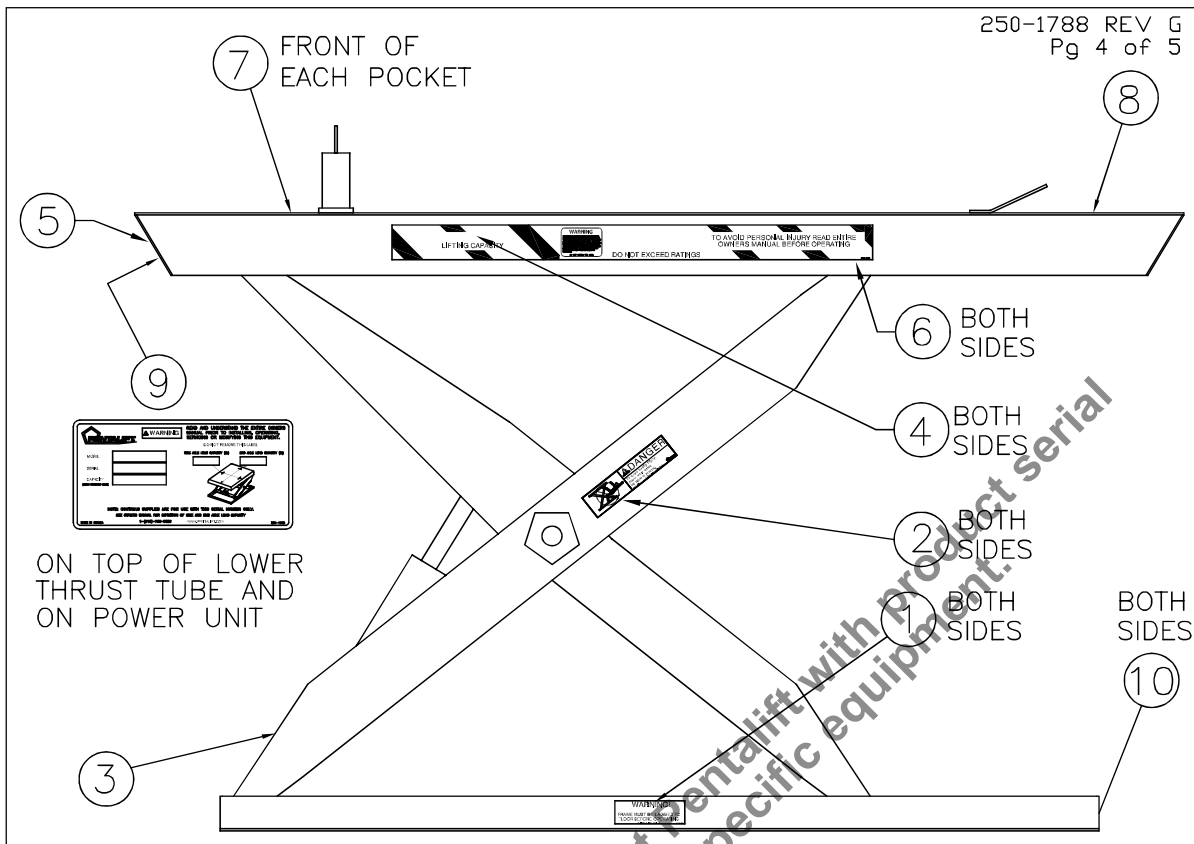

Figure 2: Safety Label and Decal Locations

Be sure that all labeling is in place and intact when the unit is received. If any of the safety labels or decals are missing or illegible, contact your Pentalift representative for immediate replacement.

NOTE: In some instances when it is not practical to place the labels on the equipment, the labels will be supplied on a separate placard. It is the owner's responsibility to confirm appropriate mounting location of the placard and have the placard visible and confirm on a regular basis that the placard continues to be visible to the operators and people working with or in close proximity of the equipment.

Note: In some instances, product configuration and / or product options may dictate that the product labels will not be placed as indicated on the drawing (Figure 2). Different label locations will be selected at the factory, when required, to avoid the viewing of the label being impaired. Note the label locations as supplied on the product, when it is received to accommodate future label replacement requirements.

NOTE: It is the owner's responsibility to ensure that all safety labeling remains legible and in its original position throughout the life of the product. It is also the owner's responsibility to ensure that all labels are and will continue to be readily visible to the operators and people working with or around the equipment. If the visibility of any label is compromised for any reason then; either 1) Rectify the situation to allow the label to be readily visible 2) Order replacement label(s) from Pentalift for installation in a location that does facilitate complete visibility. Inspection shall be done during regular maintenance and lubrication (See "MAINTENANCE AND LUBRICATION" on page 33).

To re-order labels and decals, use the following part numbers:

<u>Item</u>	<u>Part No.</u>	<u>Qty/Unit</u>	<u>Description</u>
1	250-1358	2	"WARNING - FRAME MUST BE LAGGED..."
2	250-1046	2	"DANGER... STAND CLEAR..."
3	250-1385	2	SPECIFICATION PLATE
4	NOTE	2	CAPACITY LABEL
5	250-1148	1	FINAL INSPECTION
6	250-1171	2	SAFETY STRIPE
7	250-1127	2	LIFT 1 DOCK ONLY...
8	250-1141	1	"CAUTION... THIS EQUIPMENT..."
9	250-7010	1	"WARNING... GUARD RAILS... CHAINS"
10	250-7015	2	"DANGER... DO NOT WORK UNDER..."

NOTE: State Model # and Serial # when ordering replacement parts.

Generic manual for reference only. Contact Pentlift with product serial number to receive owners manual for your specific equipment.

INSTALLATION INSTRUCTIONS



Do not install, operate or service this product unless you have read and fully understand the entire contents of this manual. Failure to do so may result in property damage, bodily injury or death.

IMPORTANT

PREPARATION PRIOR TO INSTALLATION

Perform installation instructions in the same sequence as they are listed below.



BEFORE DOING ANY INSTALLATION, MAINTENANCE, INSPECTION OR TROUBLE SHOOTING, BARRICADE ALL AREAS FROM TRAFFIC AROUND THE WORK AREA INSIDE (& OUTSIDE IF APPLICABLE) FOR SAFETY, POST APPROPRIATE WARNING SIGNS AND BE CERTAIN THAT THE POWER IS DISCONNECTED, PROPERLY TAGGED AND LOCKED OUT. ALL ELECTRICAL WORK MUST BE PERFORMED BY A QUALIFIED ELECTRICIAN IN ACCORDANCE WITH ALL APPLICABLE CODES.



Arc flash and shock hazard PPE (personal protection equipment) required. De-energize equipment before working on or inside. Do not open cover without appropriate PPE. Refer to NFPA 70E for PPE requirements. This panel may contain more than one power source. Hazardous voltage will cause severe injury or death.



MAKE SURE LIFTING AND SLINGING DEVICES ARE OF SUFFICIENT CAPACITY, USED IN THE CORRECT MANNER AND ARE IN GOOD WORKING ORDER. ALL LIFTING, POSITIONING AND INSTALLATION, AS WELL AS THE BREAK-IN AND PERFORMANCE CHECK MUST BE DONE BY QUALIFIED PERSONNEL TRAINED AND EXPERIENCED IN NECESSARY SAFETY PROCEDURES.



BE SURE ALL HYDRAULIC FITTINGS ARE RATED FOR HYDRAULIC SYSTEMS THAT MAY PEAK OUT AT 4000PSI. HARDWARE STORE ITEMS CAN BURST AT 150PSI. ONLY BUY REPLACEMENT PARTS FROM PENTALIFT.

1. Ensure pit conforms to appropriate Pentalift pit drawing. Ensure drain, if required, is in place prior to installing the dock lift.
2. Make sure the installation surface is clean, level and flat before installing the unit. A slight slope from clevis end to roller end is not a problem, but a side to side slope will cause premature wear on all moving parts of the lift. Tighten the lag bolts.

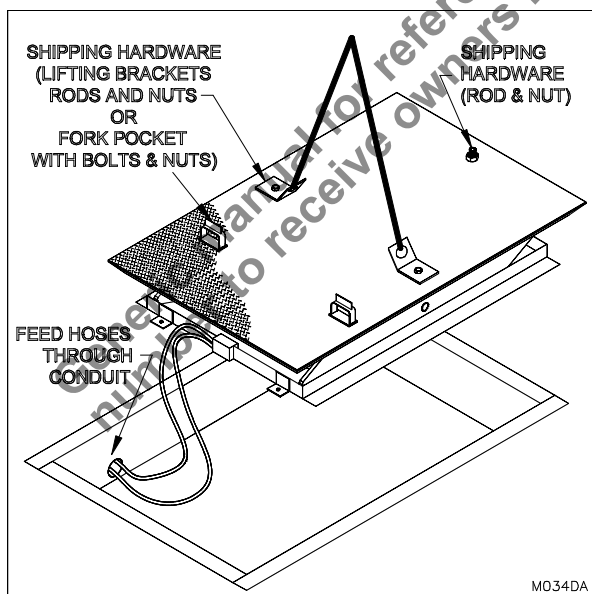

Figure 3: Moving the Dock Lift

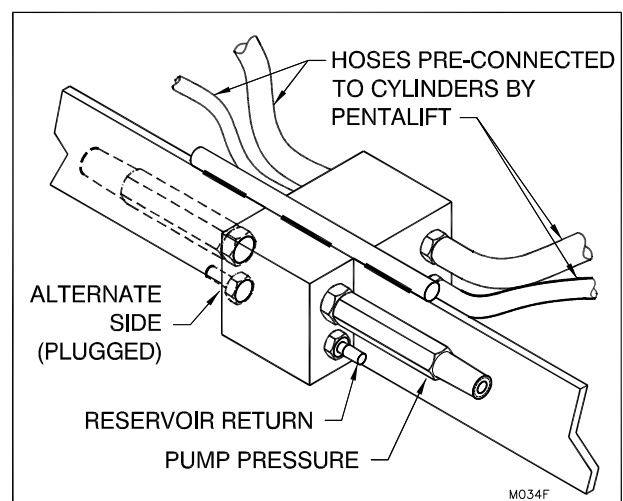

Figure 4: Connect the Hoses to Junction Block on Side Nearest to the Power Unit (utilized when three or more lift cylinders are on lift)

3. The installation surface must be capable of supporting any loads that will be applied to it.
4. As the unit is being hoisted into location, feed hoses and if required electrical wires through any conduits that have been installed for hose or wiring routing.
5. If your unit comes equipped with two or less hydraulic cylinders connect the two hydraulic hoses using the joiner that is installed on the short piece of hose coming from the lift table frame.
6. For units with more than two lift cylinders, connect the hoses using the junction block installed in the frame of the lift. The junction block is designed to facilitate connection of the hoses to the block from either side. If warranted, to accommodate a more direct path to the power unit, hydraulic plugs provided in the junction block can be switched from one side of the junction block with the fittings provided on the other side of the junction block. (See "Figure 4: Connect the Hoses to Junction Block on Side Nearest to the Power Unit" on page 5). **NOTE:** The pressure line is the larger diameter size hose of the two supplied hoses and the bypass line is the smaller diameter size hose of the two supplied hoses. Matching sizes hose connection fittings will be provided to avoid incorrect switching of the hoses.
7. Prior to hoisting the dock lift into the pit. Review and confirm all hoisting warnings and that hoisting equipment is of the appropriate capacity. Hoist the dock lift into the pit. At the same time, feed the hydraulic hose through the conduit from inside the pit toward the power unit. (See "Figure 3: Moving the Dock Lift" on page 5).



NEVER GO BENEATH THE DOCK LIFT WHILE IT IS BEING HOISTED INTO POSITION. STAY CLEAR IF THE DOCK LIFT SHOULD SHIFT OR FALL. FAILURE TO DO SO MAY RESULT IN PROPERTY DAMAGE, BODILY INJURY OR DEATH.

8. The remote power unit can be floor or wall-mounted with wall mounting the preferred method. Mounting the power unit on the wall protects the power from debris, dirt, foot and vehicle traffic that may damage the power unit. This method also prevents personnel from standing upon or placing objects on the power unit.

ENSURE UNOBSTRUCTED LINE OF SIGHT FROM PUSH BUTTON CONTROL TO EQUIPMENT AND INTO PIT WHEN EQUIPMENT IS RAISED.

Note: The hydraulic power unit and the control panel are important components of the equipment. It is important that they be installed in a location that is free from impact, dirt, debris and splashing and / or wash down. Each application has different conditions and design features. Evaluation of the specific site conditions and parameters in conjunction with common sense should be used to determine the appropriate hydraulic power unit and controls installation location. Avoid the application of a cantilever load on the power unit reservoir may damage the power unit and/or cause the power unit to leak hydraulic oil.

Wall mounting method:

Mount the power unit in the desired location using appropriate fasteners and connect the hydraulic hoses. Ideally, the reservoir should be mounted on a wall approximately 6 1/2 feet above the ground. For a power unit with a larger oil reservoir, a shelf supporting bracket supplied by others can be used to support the end of the reservoir if required (see "Figure 27: Wall Mounted Remote Power Unit" on page 8). The shelf bracket can be similar to the one depicted in "Figure 27: Wall Mounted Remote Power Unit" on page 8. Once the power unit is properly secured to the wall, mount the support shelf bracket by first ensuring the bottom leg of the shelf is in contact with the bottom end of the reservoir. Secure the vertical leg of the support shelf to the wall using appropriate fasteners.

Note: The appropriate fasteners to mount the power unit to the wall itself is the responsibility of others. The appropriateness of the fasteners is depended on the total weight of the power unit assembly and the type of wall material and construction.

Floor mounting method:

Locate and mount the power unit in the desired location and connect the hydraulic hoses. For a power unit with a larger oil reservoir where the overall length of the reservoir is equal to or greater than 16 inches (see "Figure 26: Floor Mounted Remote Power Unit" on page 7), an additional floor mounting bracket supporting the end of the reservoir will be provided along with bolts and nuts to fasten the bracket to the end of the reservoir. Note this bracket is not meant to be fastened to the floor but instead, it acts to support the end of the reservoir (see

“Figure 26: Floor Mounted Remote Power Unit” on page 7). Adjust the vertical position of the support bolt by loosening the nuts and lowering the bolt until the head of the bolt touches the floor. Tighten both top and bottom nuts to secure the support bolt in place.

Note: There are 2 tapped holes in the reservoir and only one of those holes is utilized by the floor mounting bracket.

Note: If the power unit needs to be moved, pick it up using appropriate means to prevent equipment damage or personal injuries. Never drag the power unit along the ground. Doing so will damage the power unit.

Run the hydraulic lines from the power unit to the lift and flush with clean fluid before connecting the lines. If the lines must be pushed through chases or enclosures, be sure to cap the lines to prevent contaminant from entering the hoses. Cleanliness is important in the maintenance and reliability of any hydraulic system.

9. Square the dock lift platform in the pit, leaving approximately 1" space all around the pit edge. Remove all shipping bolts and hardware. (See “Figure 3: Moving the Dock Lift” on page 5).
10. Connect the appropriate supply voltage to the motor control panel. (Refer to the **WIRING DIAGRAM** located inside the motor control panel and the electrical specification label located on the side of the motor control panel).

NOTE: All wiring must be performed by a qualified electrician in accordance with all applicable codes.

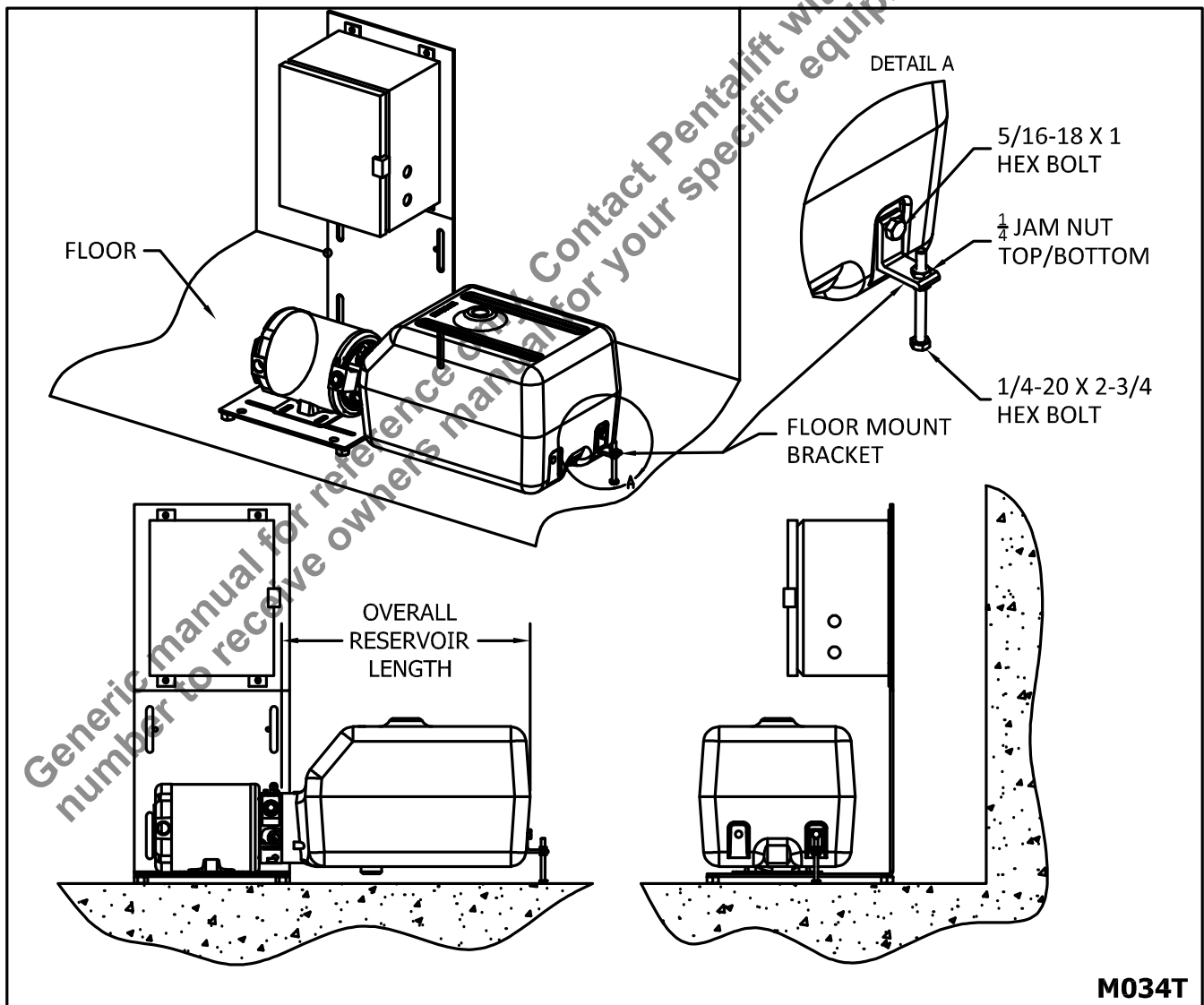

Figure 26: Floor Mounted Remote Power Unit

NOTE:

Three Phase motors:

- a. Three phase motors will rotate in either direction dependent on how the wiring polarity is completed. When using the equipment for the first time it is possible the motor is wired inappropriately for the requirements of the hydraulic power unit. When attempting to operate the equipment for the first time, if the controls are activated and the motor is rotating with no resulting movement from equipment, there is a good chance the polarity of the power supply to the motor is incorrect. To address this swap, two of the 3 wire supply connections and attempt to reactivate the equipment. If this meets without success contact your Pentalift Representative. If the motor on the power unit has a fan the direction of the fan in relation to the label indicating the appropriate rotational direction can be referenced.

Single Phase motors:

- b. Some single phase motors are bidirectional. When using the equipment for the first time it is possible the motor is wired inappropriately for the requirements of the hydraulic power unit. When attempting to operate the equipment for the first time, if the controls are activated and the motor is rotating with no resulting movement from equipment, there is a good chance the motor rotation wiring is the incorrect direction. To address this, follow the directions

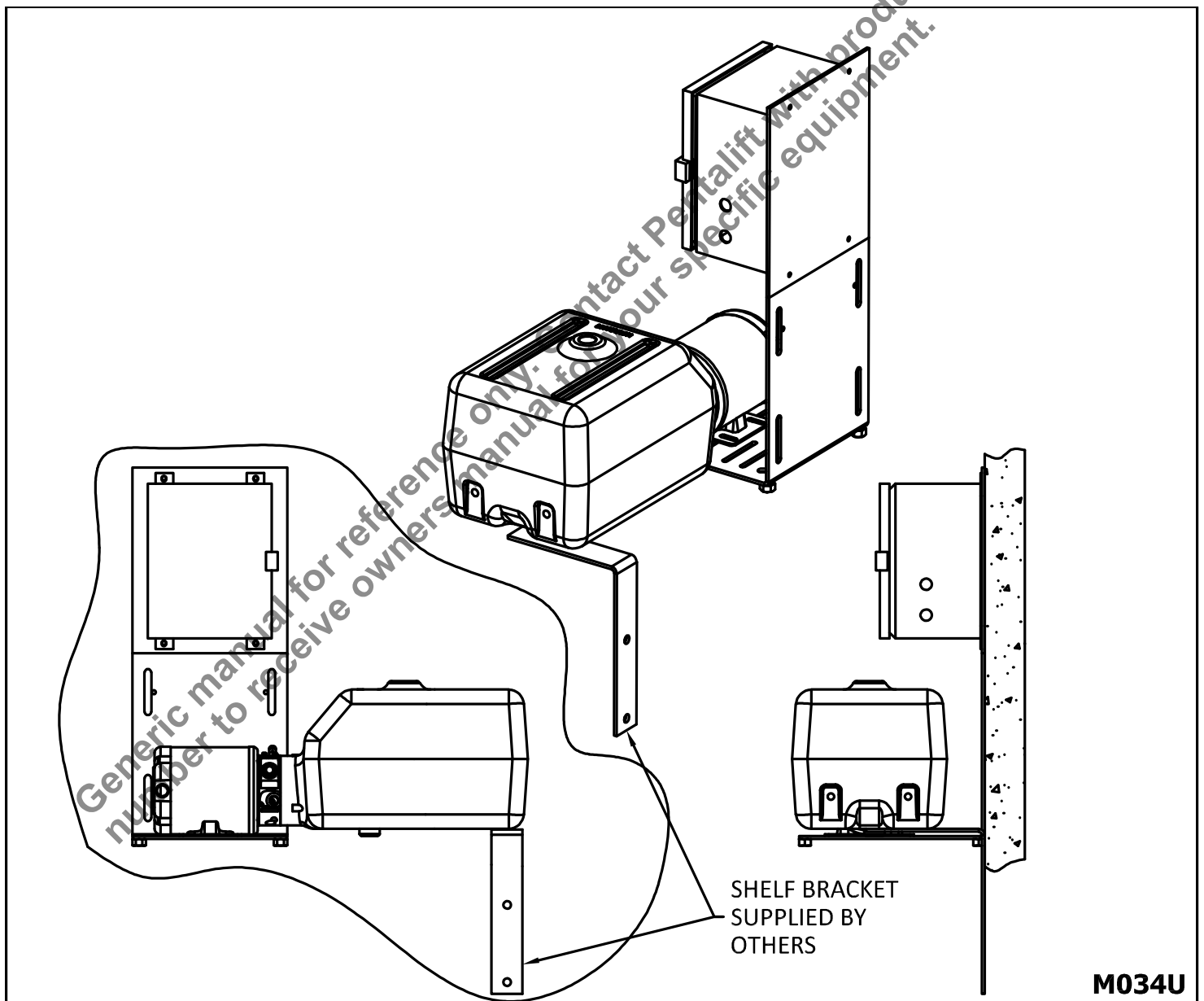

Figure 27: Wall Mounted Remote Power Unit

provide on the label on the motor to reverse the wiring direction and attempt to reactivate the equipment. If this meets without success contact your Pentalift Representative. If the motor on the power unit has a fan, the direction of the fan in relation to the label indicating the appropriate rotational direction can be referenced.

- c. To prevent tripping the motor overload relay, the motor requires the specified voltage at the motor while the motor is working under full load. If there is a problem, confirm that the supply conductors are sufficient in relation to the run length. See Electrical Reference Chart starting on page 9. Follow all applicable electrical codes.

Ensure that the thermal overload relay is set to match the full load current as shown on the motor name

ELECTRICAL REFERENCE - 1 HP							
Length of branch circuit which will have a 2% voltage drop at full load current (copper wire) ft/m. The values given are intended to be a rough wiring guide only. Be sure to check all local electrical codes before wiring.	AWG	115/1/60	230/1/60	230/3/60	380/3/50	460/3/60	575/3/60
	14	36 ft	143 ft	249 ft	865 ft	997 ft	1870 ft
	12	57 ft	227 ft	396 ft	1376 ft	1586 ft	2973 ft
	10	90 ft	362 ft	630 ft	2187 ft	2521 ft	4726 ft
	8	143 ft	575 ft	1002 ft	3478 ft	4009 ft	7518 ft
	6	228 ft	914 ft	1594 ft	5529 ft	6375 ft	11953 ft
Approximate Motor Current (full load)		12 A	6 A	4.2 A	2 A	2.1 A	1.4 A

ELECTRICAL REFERENCE - 1.5 HP							
Length of branch circuit which will have a 2% voltage drop at full load current (copper wire) ft/m. The values given are intended to be a rough wiring guide only. Be sure to check all local electrical codes before wiring.	AWG	115/1/60	230/1/60	230/3/60	380/3/50	460/3/60	575/3/60
	14		107 ft	209 ft	692 ft	838 ft	1455 ft
	12	43 ft	171 ft	333 ft	1100 ft	1332 ft	2313 ft
	10	68 ft	271 ft	529 ft	1749 ft	2118 ft	3676 ft
	8	108 ft	432 ft	842 ft	2782 ft	3368 ft	5847 ft
	6	172 ft	686 ft	1339 ft	4424 ft	5355 ft	9297 ft
Approximate Motor Current (full load)		16 A	8 A	5 A	2.5 A	2.5 A	1.8 A

ELECTRICAL REFERENCE - 3 HP							
<p>Length of branch circuit which will have a 2% voltage drop at full load current (copper wire) ft/m.</p> <p>The values given are intended to be a rough wiring guide only.</p> <p>Be sure to check all local electrical codes before wiring.</p>	AWG	115/1/60	230/1/60	230/3/60	380/3/50	460/3/60	575/3/60
	14		59 ft	87 ft	368 ft	106 ft	545 ft
	12		94 ft	139 ft	585 ft	169 ft	867 ft
	10	39 ft	150 ft	221 ft	930 ft	269 ft	1379 ft
	8	62 ft	238 ft	351 ft	1480 ft	428 ft	2193 ft
	6	98 ft	379 ft	558 ft	2353 ft	680 ft	3486 ft
Approximate Motor Current (full load)		28 A	14.5 A	12 A	4.7 A	6 A	4.8 A

ELECTRICAL REFERENCE - 5 HP								
<p>Length of branch circuit which will have a 2% voltage drop at full load current (copper wire) ft/m.</p> <p>The values given are intended to be a rough wiring guide only.</p> <p>Be sure to check all local electrical codes before wiring.</p>	AWG	115/1/60	230/1/60	230/3/60	380/3/50	460/3/60	575/3/60	
	14				87 ft	228 ft	106 ft	545 ft
	12				139 ft	362 ft	169 ft	867 ft
	10			103 ft	221 ft	575 ft	269 ft	1379 ft
	8			164 ft	351 ft	915 ft	428 ft	2193 ft
	6			261 ft	558 ft	1455 ft	680 ft	3486 ft
Approximate Motor Current (full load)			21 A	12 A	7.6 A	6 A	4.8 A	

ELECTRICAL REFERENCE - 7.5 HP							
<p>Length of branch circuit which will have a 2% voltage drop at full load current (copper wire) ft/m.</p> <p>The values given are intended to be a rough wiring guide only.</p> <p>Be sure to check all local electrical codes before wiring.</p>	AWG	115/1/60	230/1/60	230/3/60	380/3/50	460/3/60	575/3/60
	14				136 ft	223 ft	374 ft
	12			89 ft	217 ft	354 ft	595 ft
	10			141 ft	344 ft	563 ft	945 ft
	8		104.6 ft	224 ft	578 ft	896 ft	1504 ft
	6		166 ft	356 ft	871 ft	1424 ft	2391 ft
Approximate Motor Current (full load)			33 A	18.8 A	12.7 A	9.4 A	7 A

ELECTRICAL REFERENCE - 10 HP							
<p>Length of branch circuit which will have a 2% voltage drop at full load current (copper wire) ft/m.</p> <p>The values given are intended to be a rough wiring guide only.</p> <p>Be sure to check all local electrical codes before wiring.</p>	AWG	115/1/60	230/1/60	230/3/60	380/3/50	460/3/60	575/3/60
	14					145 ft	273 ft
	12				178 ft	231 ft	434 ft
	10			92 ft	282 ft	368 ft	689 ft
	8			146 ft	448 ft	585 ft	1096 ft
	6			232 ft	714 ft	930 ft	1743 ft
Approximate Motor Current (full load)				28.8 A	15.5 A	14.4 A	9.6 A

SELF CONTAINED POWER UNITS:

If the power unit is self-contained (which is not common and non-standard), ensure the temporary wire is routed out of the pit for easy hook-up.

NOTE: The temporary wires supplied are intended to be used for lifting the platform for the initial installation only. Once the maintenance stand is in position, the temporary wires are to be removed from both the power supply and the dock lift. Permanent wiring must be installed immediately.

NOTE: The temporary wires should be connected only if they meet the requirements of the applicable local electrical codes. If they do not, the electrician should rewire to meet all applicable codes prior to applying any electrical power.

plate. Follow all applicable electrical codes.

11. Square the dock lift platform in the pit, leaving approximately 1" space all around the pit edge. **NOTE:** If the unit is equipped with a roll-off stop, the platform must be squared evenly on the two sides and offset by 11" on the fixed end (See "Figure 5: Square the Dock Lift in the Pit" on page 12).
12. Raise the unit to its maximum height and then fully lower. Repeat the cycle a minimum of three times. This allows the table to realign itself after shipping.
13. Re-check the unit to ensure it is square in the pit and has the desired spacing from the pit edge on all four sides.
14. If required, level the unit on both sides by shimming under the four lag locations, the full length and width of the roller travel and the lower fixed end clevises. (See "Figure 6: Shim Beneath the Fixed End Clevises and Full Roller Travel" on page 13)
 - a) Shim Information ("Figure 6: Shim Beneath the Fixed End Clevises and Full Roller Travel" on page 13):

The recommended sizing for shims at the lagging brackets is 4" x 4" and in the fixed end leg clevis locations and completely under the frames in the other lagging locations. The recommended sizing for shims under the rollers are 3" x 36" for single roller arrangement and 6" x 36" for dual roller arrangement. Dual roller arrangement is used for higher capacity lifts. Make sure these shims are located centered directly under the rollers and support the entire roller travel. Shims can be various thicknesses and can be stacked to accommodate the required final shimmed height of the dock lift. Shims that are stacked must be welded together and to the dock lift frame. Failure to shim properly will result in damage to the frame and other equipment issues.
15. Fully raise the dock lift and block the scissor mechanism following the instructions in HOW TO SUPPORT THE DOCK LIFT DURING ROUTINE MAINTENANCE AND INSPECTION (See page 32).
16. When installing into a concrete pit after shimming is complete, lag the unit to the pit floor with recommended fasteners, 5/8" Dia. x 5" long wedge anchors with a minimum shear value of 8,030 lbs. (35.7 kN), and tension value

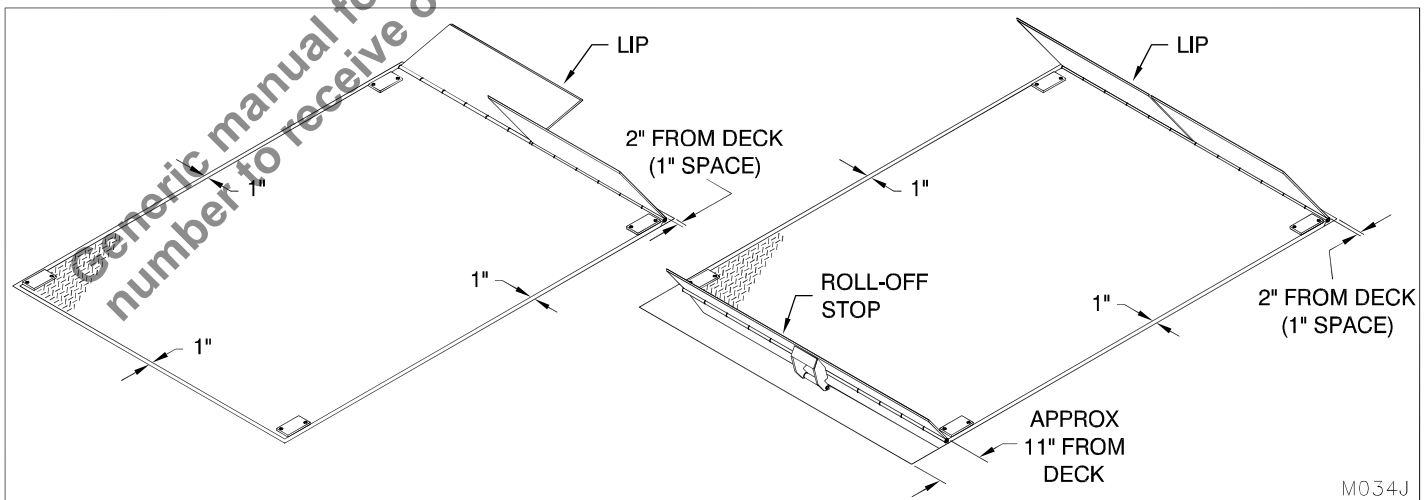

Figure 5: Square the Dock Lift in the Pit

of 8,600 lbs. (38.2 kN), or 1/2" Dia. x 4" long wedge anchors with a minimum shear value of 8,030 lbs. (35.7 kN), and tension value of 5,190 lbs. (23.1 kN). The size of the wedge anchors will depend on the platform length and capacity of the dock lift (See "Figure 28: Lag Bracket and Wedge Anchor Configurations" on page 14). Torque to manufacturer specifications. If the mounting surface is not concrete, utilize a fastener to suit the structural values indicated and appropriate for the mounting surface. If the dock lift is being installed on a surface other than concrete then use other suitable fasteners to achieve the same holding force requirements.



Note the lagging means and providing the specified strength of the lagging means are critical in accommodating side and end edge loading. Failure to accommodate the stated lagging requirement may result in serious injury or death)

17. Install the guard rails as shown in "Figure 7: Guard Rail Installation" on page 15. In some applications such as full depth pits, platform mounted guard rails can create a potentially hazardous condition by creating a pinch point between the guard rail horizontal bars and the edge of the pit floor. It may be necessary to provide protection around the perimeter of the pit. Consult applicable safety and building codes.

It is the owner's responsibility to ensure protection is provided for the operator (i.e. access chains) to prevent falling off of the dock lift when the unit is above ground/floor level.

18. Check the oil level in the power unit reservoir and add if necessary (See "MAINTENANCE AND LUBRICATION" on page 33)

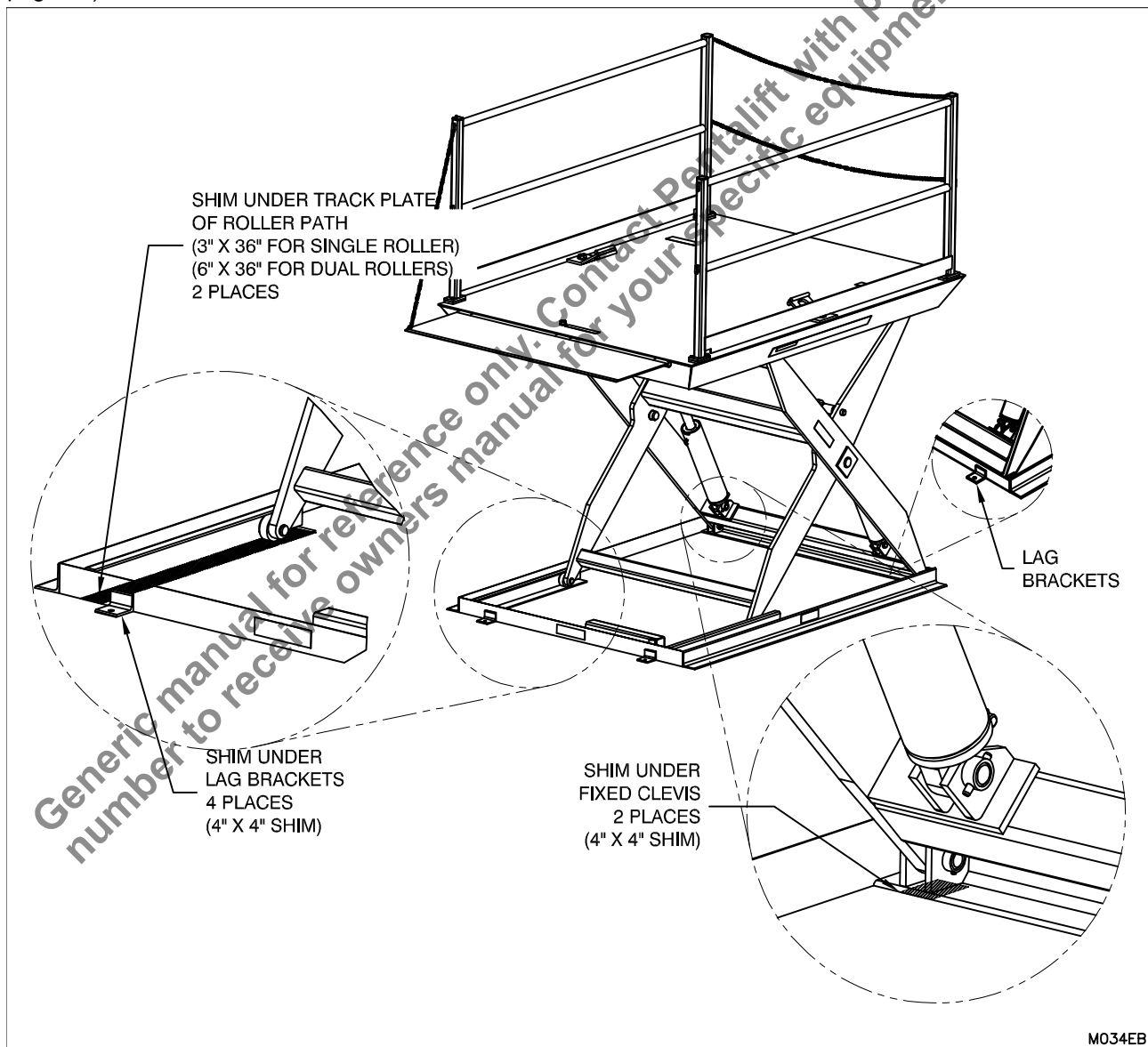

Figure 6: Shim Beneath the Fixed End Clevises and Full Roller Travel

Platform Length (in)	Capacity (pound-force)	Wedge Anchor Size (in)	Min. Embedded Depth (in)	No. of Lag Brackets on Fixed End	No. of Lag Brackets on Rolling End
96	Less than or equal to 6000	½ x 4 long	3	2	2
108 to 120	Less than or equal to 4000				
96	Greater than or equal to 8000			4	
108 to 120	Greater than or equal to 5000				
144	Less than or equal to 8000				
144	Greater than or equal to 10000	5/8 x 5 long	3-3/4		

Figure 28: Lag Bracket and Wedge Anchor Configurations

19. Clean up any debris and/or spilled oil from the area. Check all hydraulic fittings for leaks.

20. INITIAL SET-UP: It is important to purge air from the hydraulic system. To do this, raise the unit to its maximum raised height and allow the power unit to run for a minimum of 30 seconds additional time. Fully lower the unit. Discontinue use of the unit for 20 minutes to allow air to dissipate from the oil in the reservoir.

NOTE: Units equipped with an up travel limit switch will not reach their “maximum raised height” unless the limit switch is removed. The up travel limit switch must be removed to purge the air. **DO NOT remove the up travel limit switch until first ensuring there are no obstructions in the operating path of the equipment.** After the air has been purged, lower the dock lift to its desired raised height and reinstall the limit switch.



NEVER GO BENEATH THE DOCK LIFT FOR ANY REASON UNLESS THE PLATFORM AND HINGED BRIDGE(S) ARE PROPERLY SUPPORTED (See “Figure 17: How to Support the Dock Lift for Maintenance” on page 32) AND THE POWER IS DISCONNECTED, PROPERLY TAGGED AND LOCKED OUT. IT IS THE RESPONSIBILITY OF THE OWNER TO ENSURE THAT NO LOAD OR TRAFFIC IS PLACED ON THE PLATFORM WHILE THE MAINTENANCE STAND IS ENGAGED. THE CONSTRUCTION OF THE MAINTENANCE STAND IS INTENDED TO SUPPORT THE WEIGHT OF THE UNLOADED DOCK LIFT ONLY.

NOTE: At the completion of the installation ensure that all labels are and will continue to be readily visible to the operators and people working with or around the equipment. If the visibility any of the label(s) are compromised for any reason then; either 1) Rectify the situation to allow the label to be readily visible 2) Order replacement label(s) from Pentalift for installation in a location that does facilitate complete visibility.

21. Meet with the facility manager or maintenance foreman and turn over this maintenance manual with the reminder that no one is allowed to operate the unit unless they fully understand the operating instructions. Show them the maintenance stand and other safety devices. Point out the serial number plate location on the unit with the serial number and capacity ratings. Make it clear that some specific person in their organization must be charged with responsibility for the maintenance of the unit.

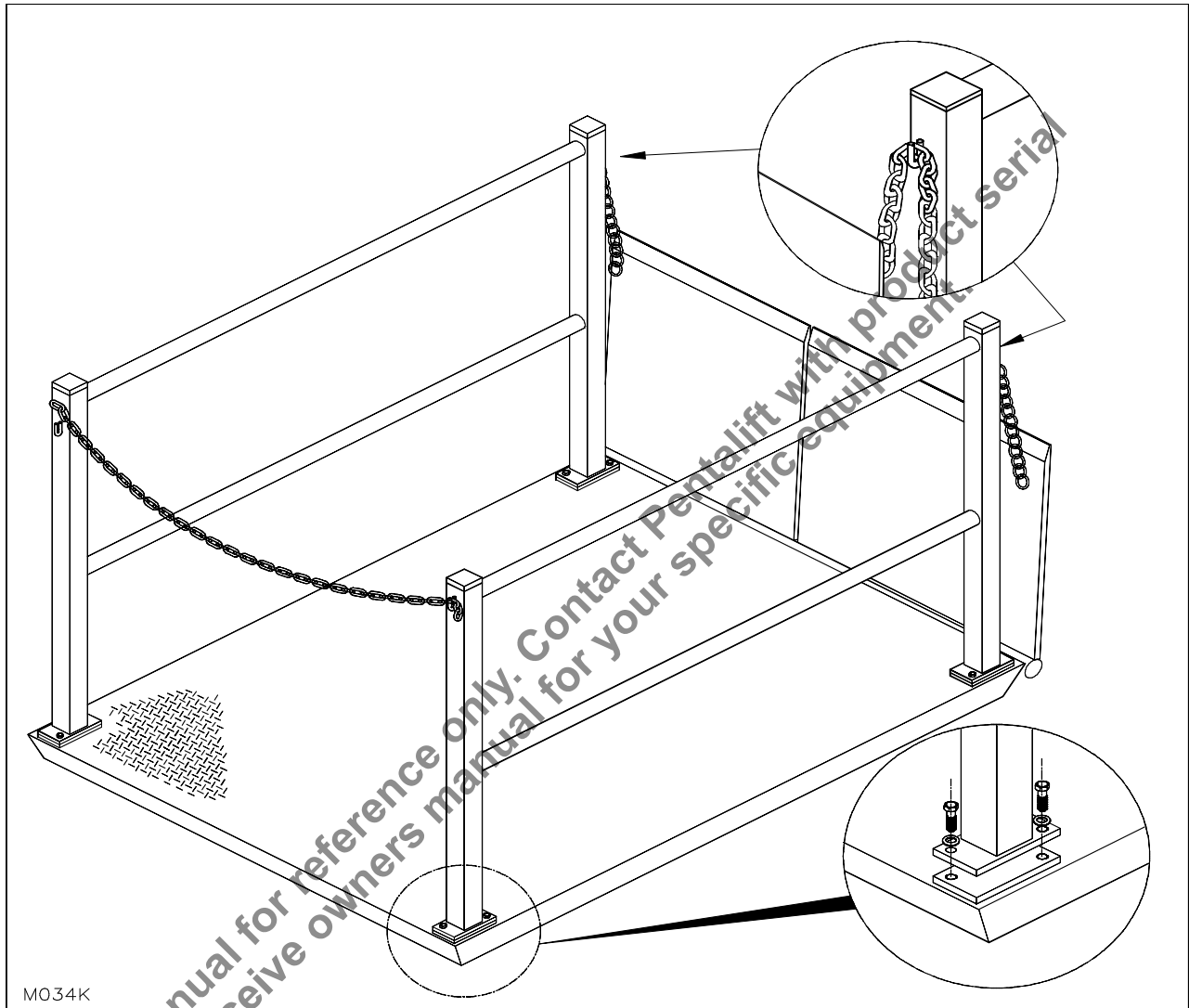

Figure 7: Guard Rail Installation

THREE SIDED PIT INSTALLATION

⚠️ WARNING

When a dock lift equipped with guard rails is lowered, the horizontal rails of the guard will lower and as it approaches the edge of the 3 sided pit there is a potential pinch point occurring. (See “Figure 8: Three Sided Pit Potential Pinch Points” on page 16) It is the responsibility of the end-user to be aware of this serious hazard and take precautions to eliminate the risk of serious injury or death.

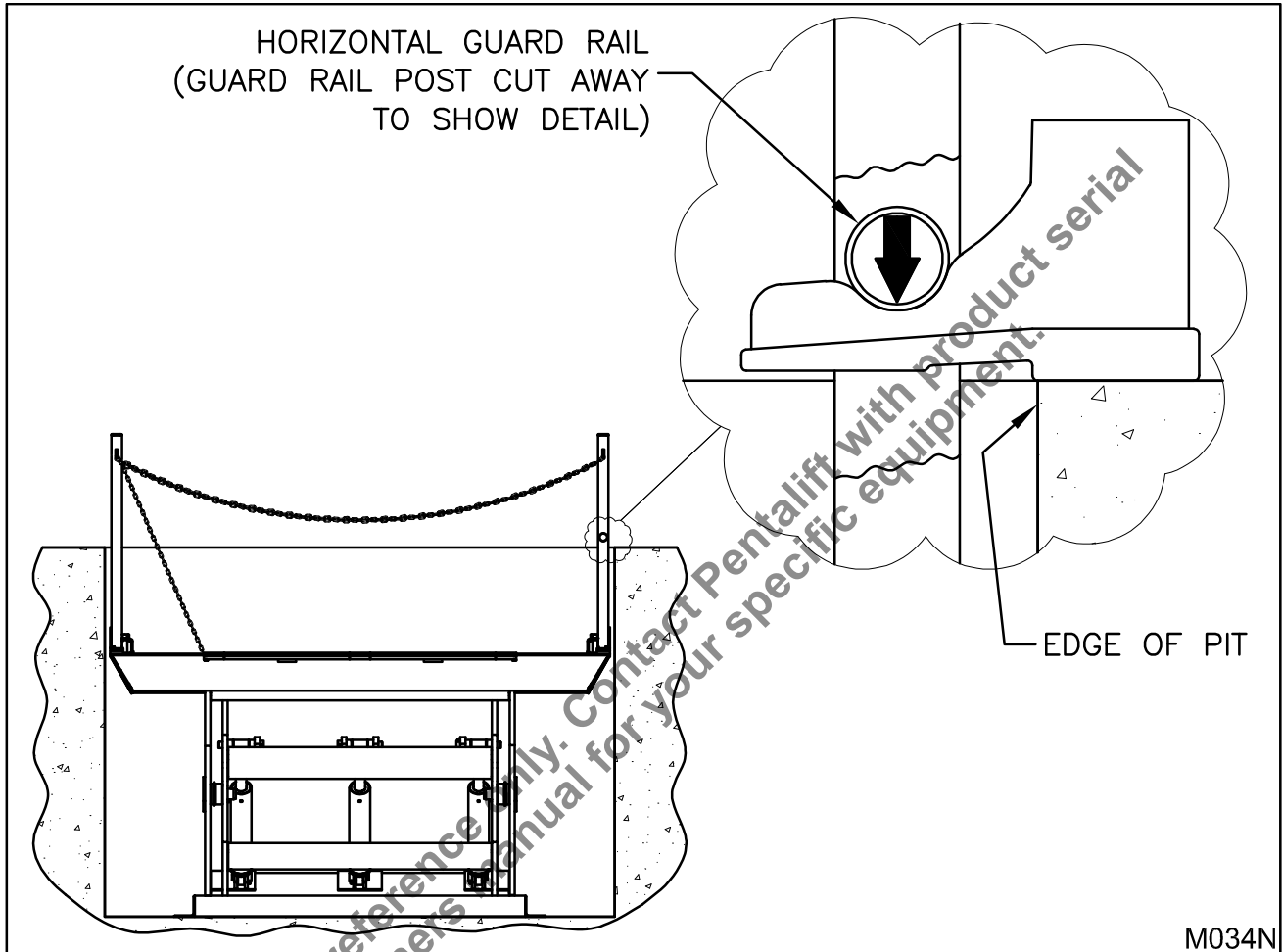

Figure 8: Three Sided Pit Potential Pinch Points

⚠️ WARNING

In applications where the dock lift is installed in a three sided pit, as the dock lift lowers, the horizontal members on the guard rail may create a pinch point as they pass the edge of the pit (See “Figure 8: Three Sided Pit Potential Pinch Points” on page 16). This can be addressed by:

1. Ordering the platform mounted guard rails with optional mesh side covering from the factory (See “Figure 9: Guard Rails with Mesh Side Covering” on page 17).
2. Increasing the gap of the sides of the dock lift pit to a minimum of 2” per side.
3. Remove the guard rails from the platform of the dock lift and have guard rails installed on the adjacent sides of the pit on the dock floor (See “Figure 10: Guard Rails Mounted on Dock Floor” on page 17). Note: Guard rails must be set back. **Note:** This arrangement is only suitable if the dock lift does not travel higher than the dock floor level.

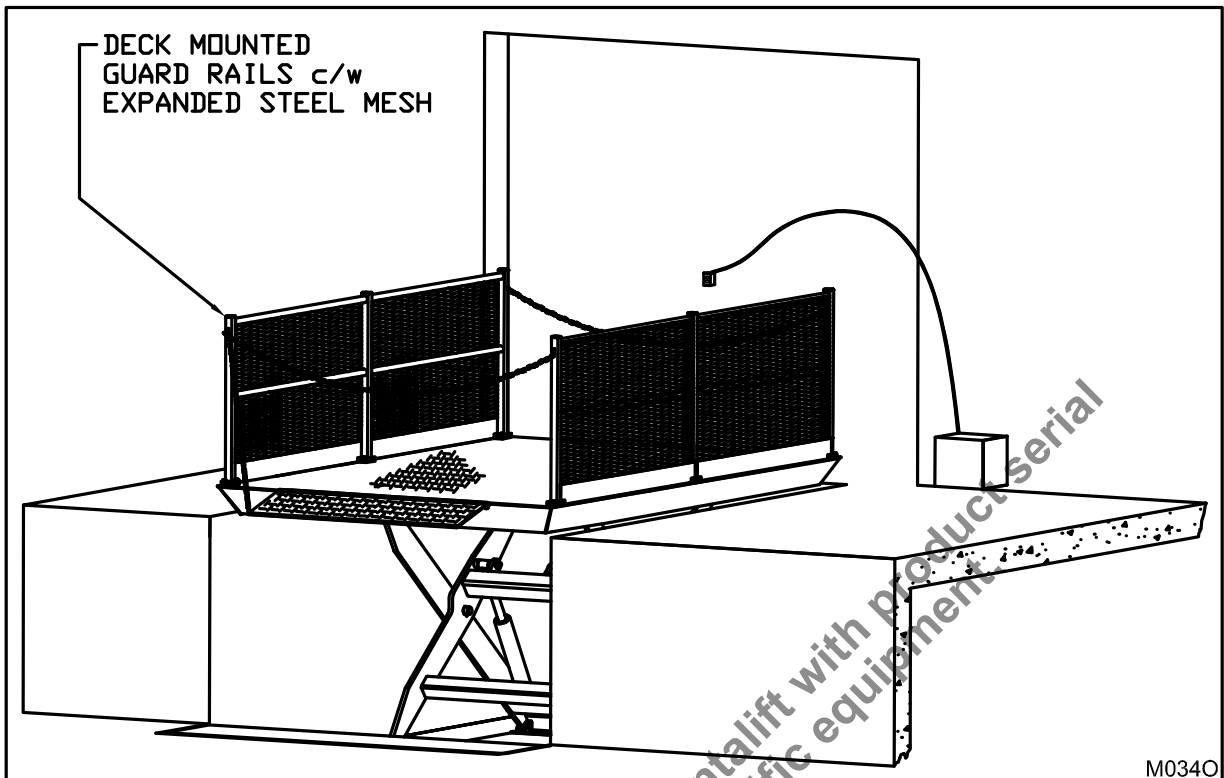

Figure 9: Guard Rails with Mesh Side Covering

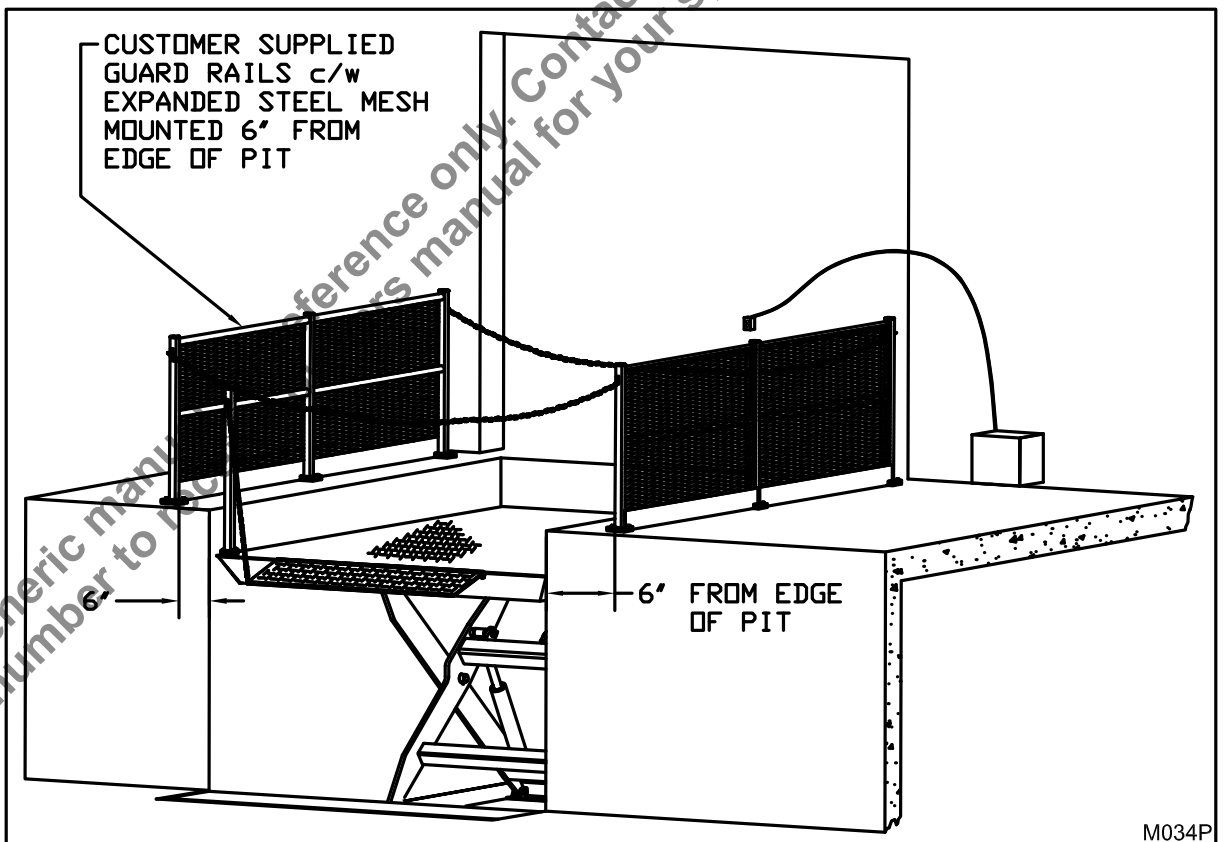

Figure 10: Guard Rails Mounted on Dock Floor

UP TRAVEL LIMIT SWITCH INSTALLATION (OPTIONAL)

NOTE: The instructions described below are for a typical HED dock lift.

NOTE: This arrangement is designed to stop travel in the upper 30 inches of travel of the lift. It is not intended to stop travel in the lower travel range of the lift.

Prior to installing the limit switch to the equipment, the installer must read the owner's manual and follow the SAFETY INFORMATION/WARNING and HOW TO SUPPORT THE DOCK LIFT DURING ROUTINE MAINTENANCE AND INSPECTION section of the owner's manual (see page 32).

The installer must also read the OPERATION OF SWITCH (see "Figure 13: Operation of Switch" on page 20) and become familiar with the adjustment procedures.

1. The location of the switch shown below is for a typical HED dock lift.
2. The switch must be located in such a way that it does not interfere with the full range of motion of the equipment. If this is not done, damage to the switch due to the interference may occur. The switch must be clear of hydraulic hoses or hydraulic manifold block. In addition, the switch must not be located too close to the inside of the leg such that replacement of the fixed clevis pin is difficult. Leave 11.5 inches between the end of the clevis pin and the bracket (see "Figure 11: Limit Switch Position" on page 19).
3. Once the proper location has been established, raise the equipment to the desired stopping height and properly brace the equipment (see "HOW TO SUPPORT THE DOCK LIFT DURING ROUTINE MAINTENANCE AND INSPECTION" on page 32) before proceeding.
4. Weld the switch bracket to the inside surface of the frame (see "Figure 12: Switch & Actuator Bracket Side View" on page 19)
5. Mount and secure the switch.
6. Secure the wand to the switch at approximately 45° to horizontal.
7. Screw the actuator and the nut to the actuator bracket. Do not tighten the nut at this time.
8. Next step is to locate the actuator/actuator bracket. The actuator should be aligned with the wand and located in such a way that a fully extended wand can still make contact with the actuator. Mark the location of the bracket.
9. Weld the actuator bracket to the lower thrust beam.
10. Review the operation of the switch (see "Figure 13: Operation of Switch" on page 20).
11. The activation angle is approximately 28° relative to the starting angle of the wand. There is an audible click when this occurs.
12. Get the actuator and the wand making the switch for the desired raise height. Adjust both the actuator upwards and the wand downwards toward the actuator. Make the required adjustments until there is a audible click that can be heard and/or felt.
13. Make sure the wand is secure to the switch body by tightening the screw.
14. Secure the actuator by tightening the nut.
15. Raise the dock lift and carefully remove any bracing (see "SAFETY INFORMATION AND WARNINGS" on page II and "HOW TO SUPPORT THE DOCK LIFT DURING ROUTINE MAINTENANCE AND INSPECTION" on page 32)
16. Lower the dock lift and then raise it.
17. Confirm that the desired raised height has been achieved. If not, re-adjust the actuator and/or wand position.

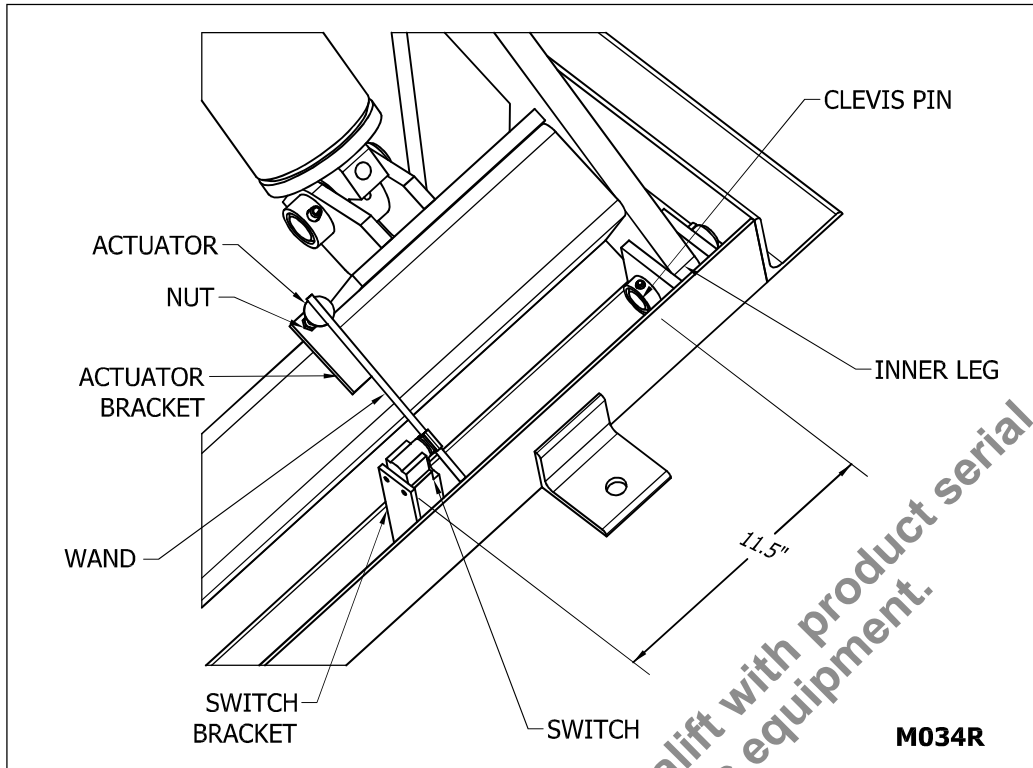

Figure 11: Limit Switch Position

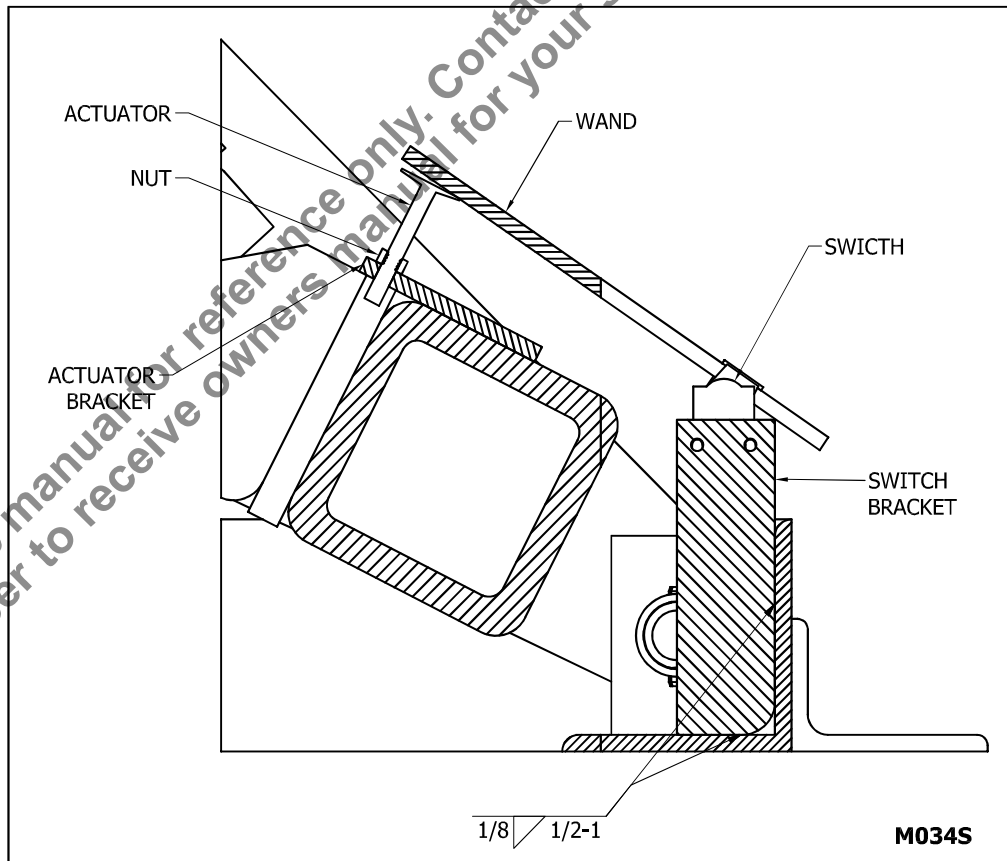

Figure 12: Switch & Actuator Bracket Side View

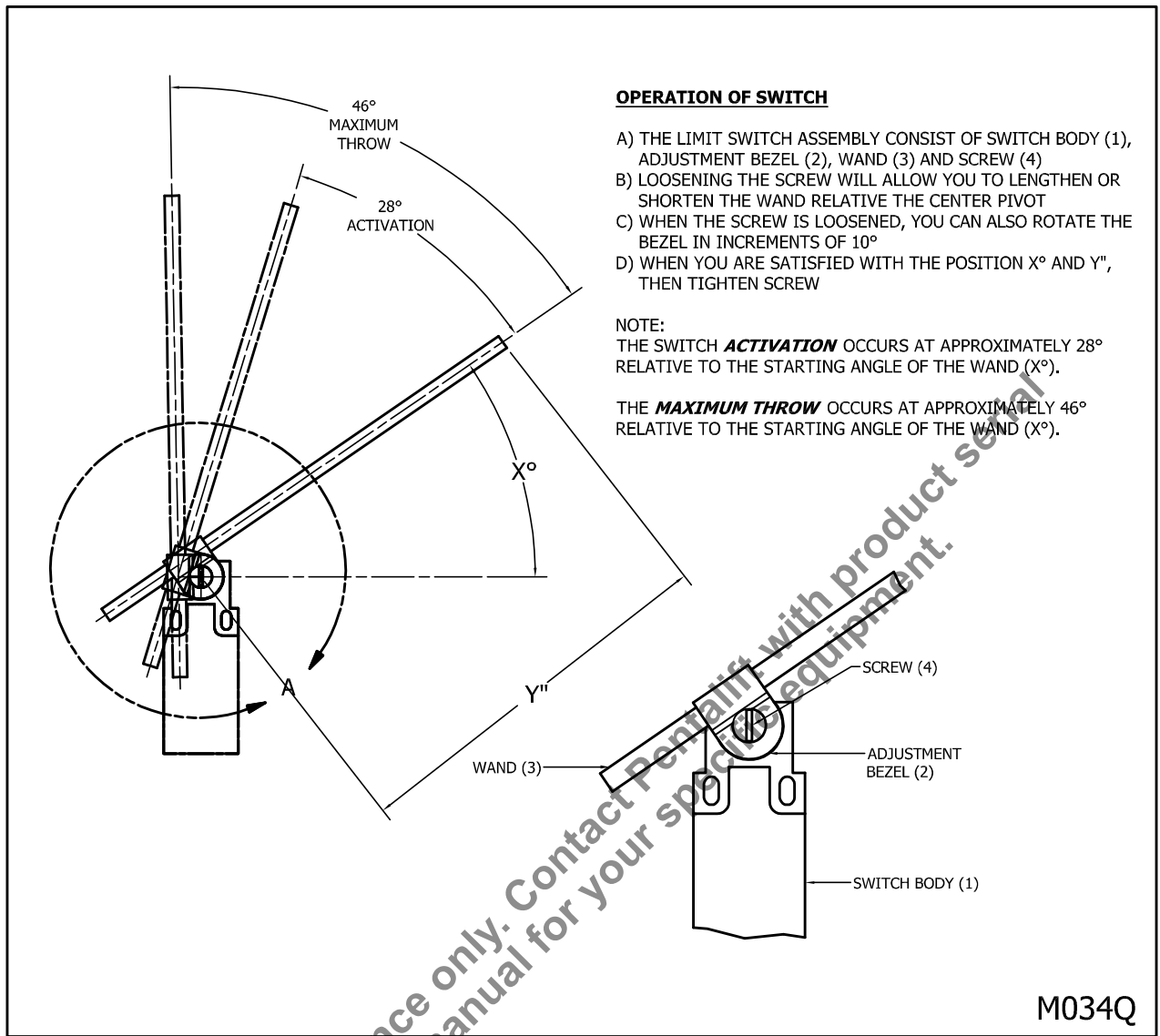

Figure 13: Operation of Switch

HINGED BRIDGE LIFT ASSIST(OPTIONAL)

DANGER

- **WIRING MUST BE DONE BY A QUALIFIED ELECTRICIAN.**
- **ALWAYS USE APPROPRIATE LOCK-OUT PROCEDURES DURING ANY ELECTRICAL INSTALLATIONS.**
- **ASSURE SUPPLY VOLTAGE IS CORRECT.**
- **ALWAYS OBSERVE ALL APPLICABLE ELECTRICAL CODES.**

Positioning and welding Hydraulic Hinged Bridge Assist

NOTE: Once the maintenance stand is in position, locate the hydraulic hinged bridge assist assembly and bridge clevis as indicated by “Figure 22: Hydraulic Hinged Bridge Assist” on page 22. The assembly should be located on the B or D side of the deck and as close to guardrail as possible. The location of existing power pack and control panel for the dock lift will dictate the positioning. Once the Hinged Bridge Lift Assist is in position, secure the assembly by welding in place as indicated by “Figure 22: Hydraulic Hinged Bridge Assist” on page 22. Position the hinge bridge in an extended horizontal position and weld the end of Bridge Chain Assembly to the hinged bridge all around. It is highly recommended that the lifting chain of the Bridge Chain Assembly is in-line with the actuator arm of the Hinged Bridge Lift Assist assembly for a trouble-free operation. If this is not possible due to the narrow width of the hinged bridge, then welding an offset lifting bar to the underside of the hinged bridge will be required. A sufficient length of lifting bar material will be shipped loose to handle various width of hinge bridges. Establish the required offset length and overlap required for welding and cut off any excess material. Ensure that the lifting bar is not too long such that it hits the guardrails when storing the bridge in the vertical tilt-back position. If the length of the hinged bridge is short and welding the lifting bar to the underside of the bridge prevents the bridge from making contact with the bed of the trailer, then weld the lifting bar to the top side of the bridge. Note, this alternate position will slightly reduce the useable width of the bridge. After these steps have been performed, weld the end of the Bridge Chain Assembly to the top surface of the lifting bar. (see “Figure 29: Lifting Bar for narrow hinged bridge” on page 23).

Installing Power Cord

NOTE: Once the maintenance stand is in position, the supplied power cord & plug assembly is to be altered as follows. Permanent wiring must be installed immediately. Install GFI 115/1/60 female receptacle (by others) on the wall closest to the main dock lift hydraulic/electrical utilities (see “Figure 23: Option#1 - Routing of Power Cord” on page 24). Use the supplied power cord running from the Hinged Bridge Assist Control Box to connect to the GFI receptacle on the wall by:

- Cutting off the 115/1/60 plug from the supplied power cord
- Route the power cord under the kick plate and over the edge of the deck
- Run the the power cord along the bevel toe guard surface and under the deck
- Continue the run over to the outer leg (vertical surface) of the scissor lift
- Continue the run towards the lower cylinder thrust beam
- Next run the power cord along the top surface of the thrust beam and near to the middle of thrust beam
- Continue the run through the U-bracket and down to the lower edge of the dock lift frame
- Run the power cord through an electrical conduit and up to the GFI receptacle (by others)
- During this routing ensure that the power cord does not come in the path of any moving parts of the dock lift
- Secure the power cord to surfaces using appropriate P- clips (by others)
- Once the power cord is properly routed to the GFI receptacle, cut any access off and reinstall the supplied 115/1/60 plug that was provided on the cord. Discard the access material that was cut off

If an electrical conduit does not exist or putting one in is not practical then follow this alternate installation procedure (see “Figure 24: Option#2 - Routing of Power Cord” on page 25):

- Cut off the 115/1/60 plug from the supplied power cord
- Install a junction box on the same side as the hinged bridge lift assist and to the corner of the deck
- Route the power cord to the junction box and cut off any access cord and discard
- Install an appropriate retractable power cord (by others) of sufficient length from the junction box to an appropriate power source
- Connect the power cord and the retractable power cord in the junction box
- During this routing ensure that the power cord does not come in the path of any moving parts of the dock lift or cross traffic operations

NOTE: The supplied power cord & plug assembly shall be connected only if they meet the requirements of the applicable local electrical codes. If they do not, the electrician shall rewire to meet all applicable codes prior to applying any electrical power.

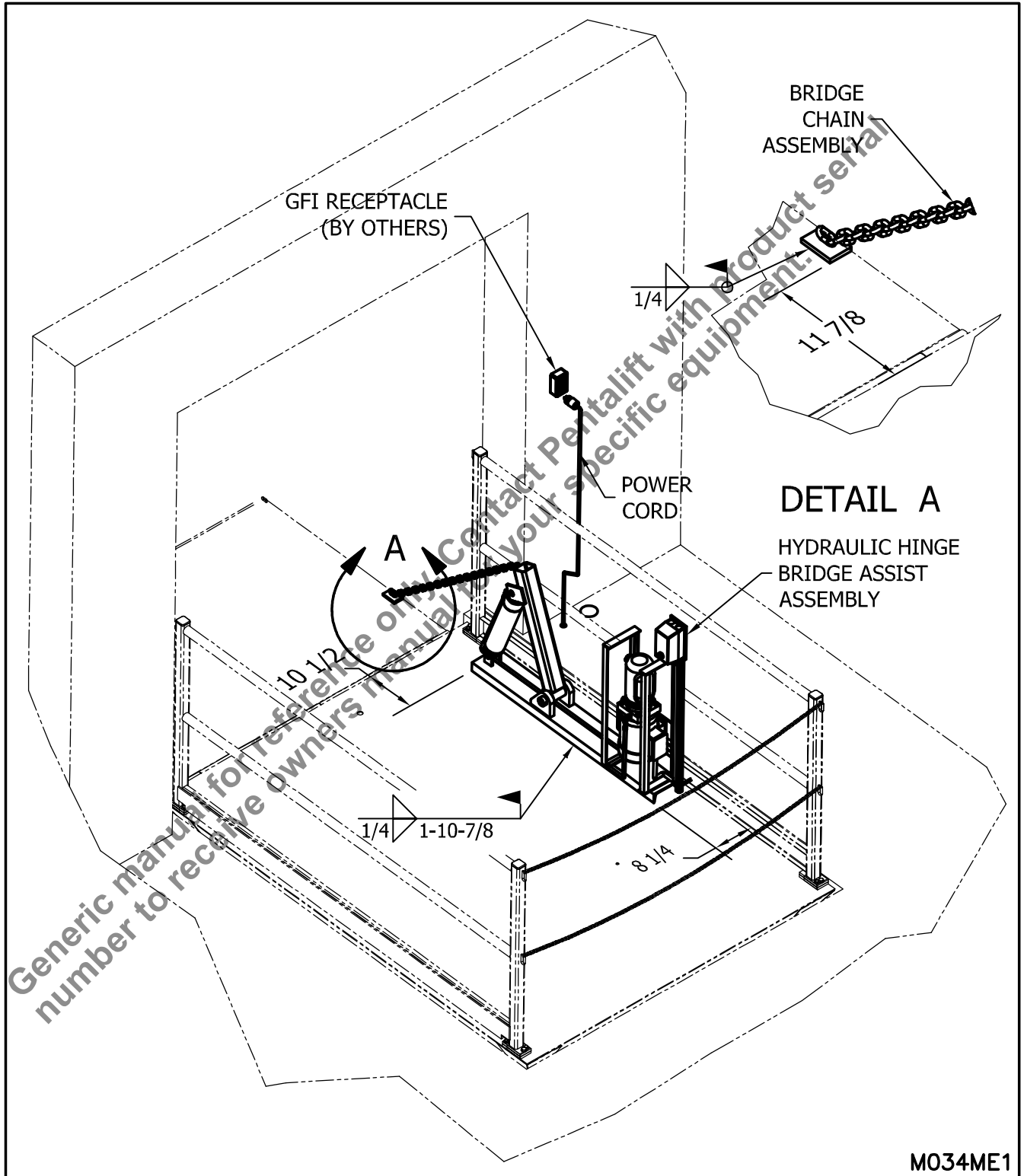

Figure 22: Hydraulic Hinged Bridge Assist

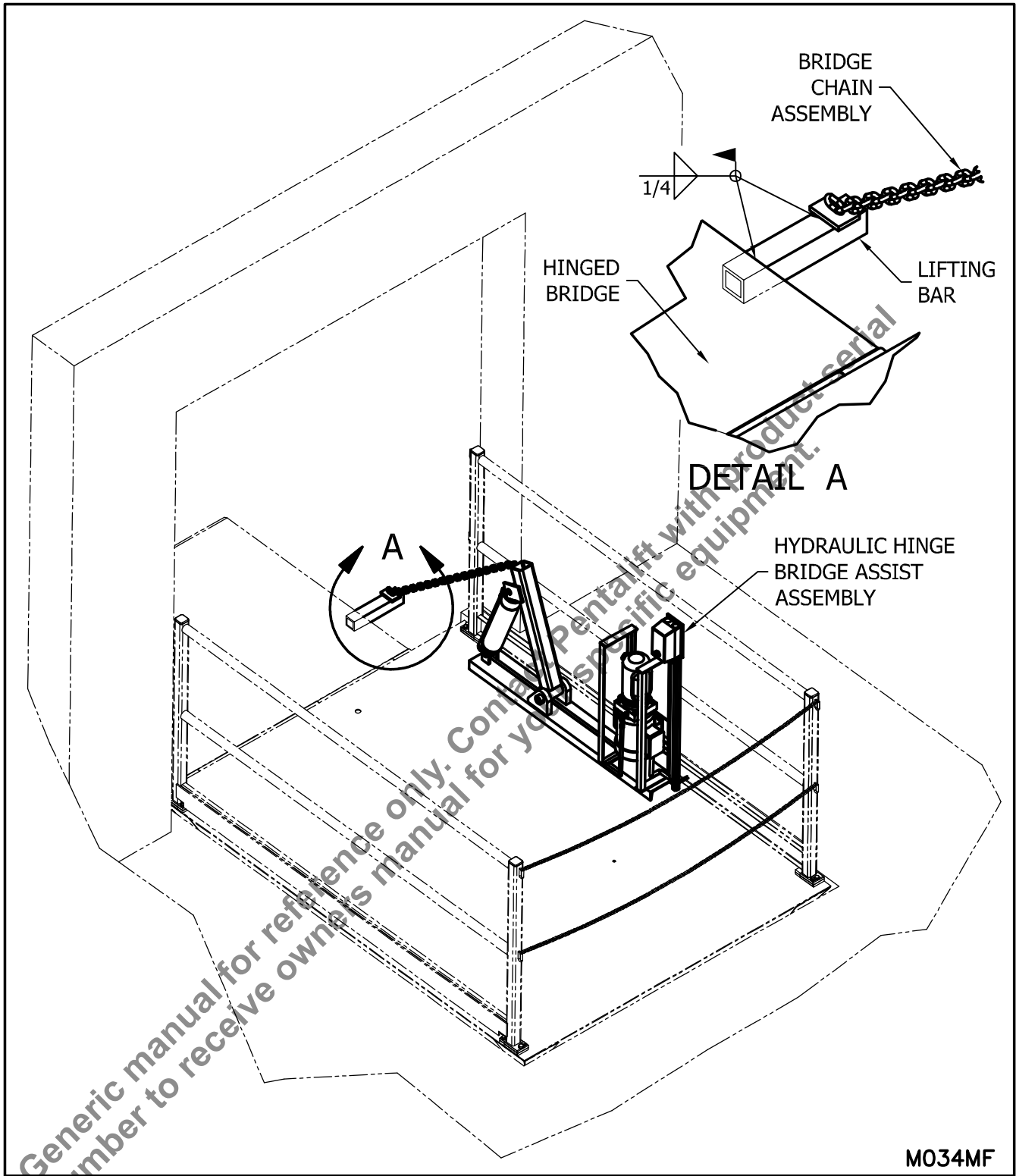

Figure 29: Lifting Bar for narrow hinged bridge

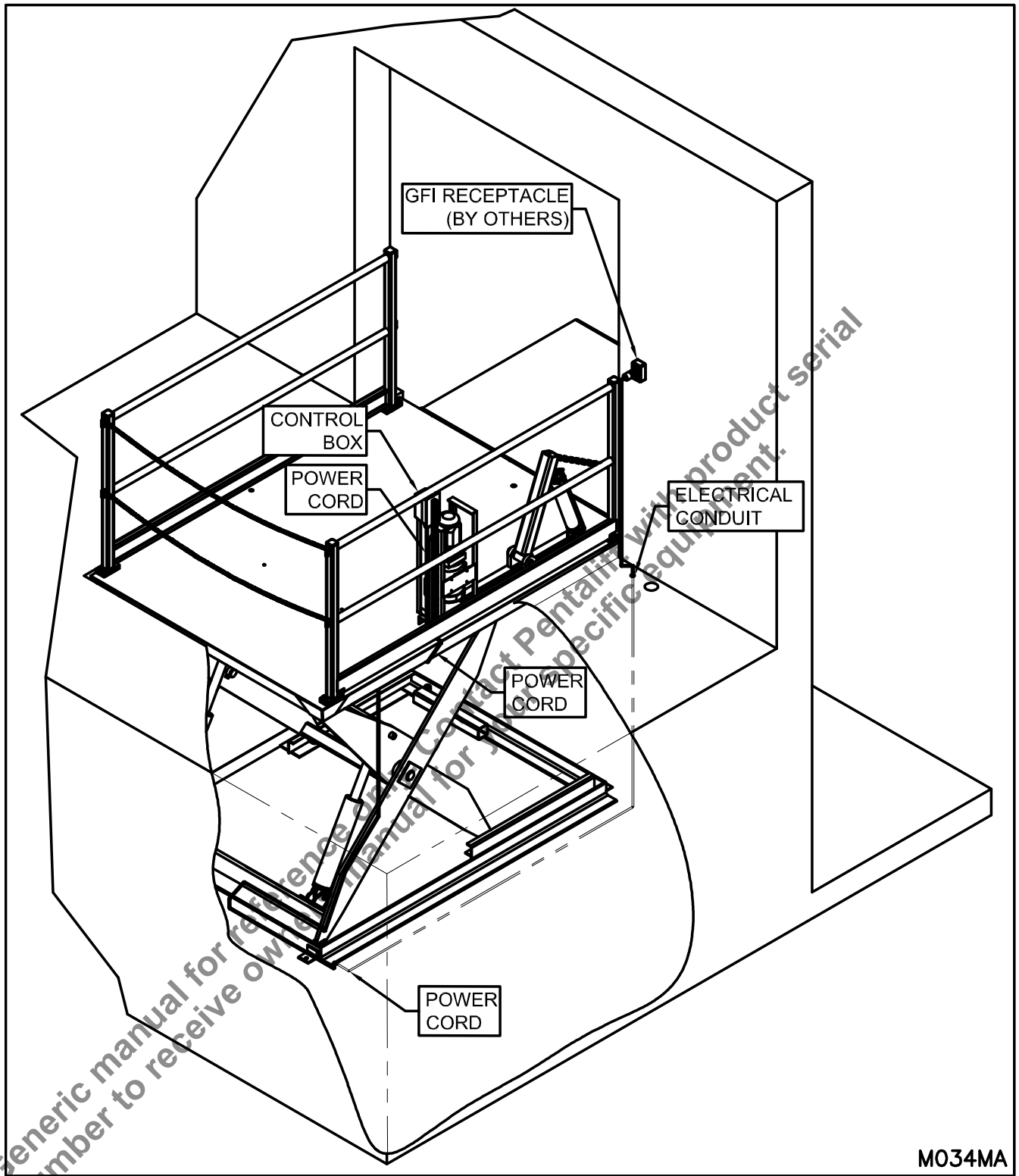

Figure 23: Option#1 - Routing of Power Cord

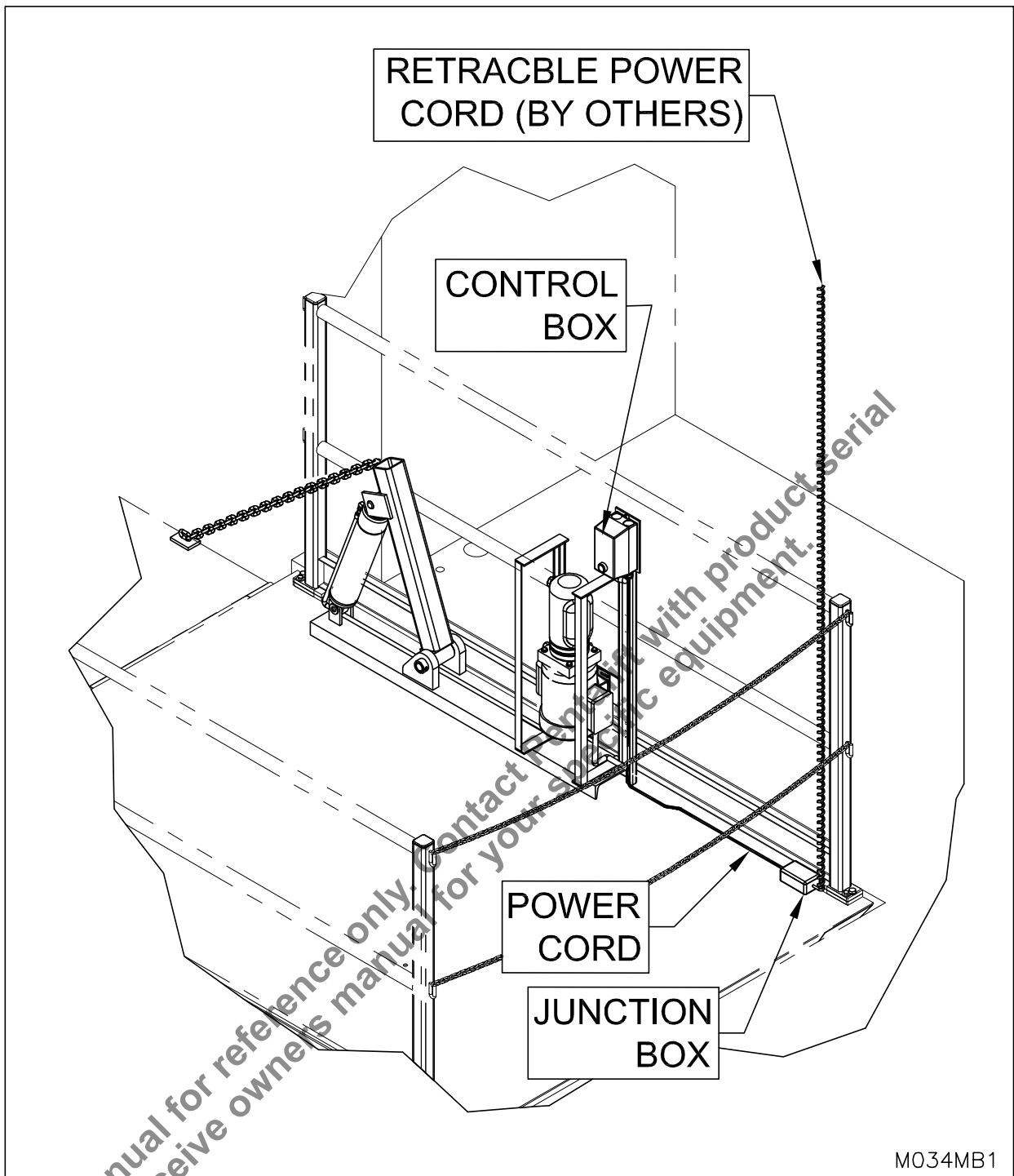

Figure 24: Option#2 - Routing of Power Cord

NIGHT LOCKS (OPTIONAL)

Prior to installing the night locks to the equipment, the installer must read the owner's manual and follow the **SAFETY INFORMATION/WARNING** and **HOW TO SUPPORT THE DOCK LIFT DURING ROUTINE MAINTENANCE AND INSPECTION** section of the owner's manual (see "HOW TO SUPPORT THE DOCK LIFT DURING ROUTINE MAINTENANCE AND INSPECTION" on page 32)

NOTE: The night locks provides a means to mechanically hold the dock lift deck at the same level as the top of the full depth pit. This prevents the dock lift from drifting down due to leakage of hydraulic fluid through the hydraulic valve. This option is not meant to hold or support the working load.

The procedure below is for the field installation of the night lock option:

1. Remove guard rails and position the four night lock assemblies as indicated in "Figure 24: Night Locks Installation" on page 27. Make sure the night locks are orientated in the correct position. The support block is on the deck side and the locking block is on the dock floor side.
2. Make sure the support blocks and locking blocks are square and level. Ensure there is full surface contact between the locking block and the dock floor. If not the night lock assemblies will need to be shimmed.
3. Once all the night lock assemblies have been squared and levelled, weld the support blocks of the night lock assemblies in place as indicated in "Figure 24: Night Locks Installation" on page 27. **Do not place welds on the inside of the support block plates.** Doing so will prevent the locking blocks from fully swinging out of the away during normal equipment operation.
4. Modify the kick plate as indicated in "Figure 25: Night Locks Installation - Guardrails" on page 28. Weld the vertical kick plate rails in place as indicated in the illustration.
5. Test the operation of the night lock assemblies to make sure the locking blocks will swing freely up and down. To lock and unlock the locking block, insert or pull out the retaining pin. There will be dead load working against the night locks. You may need to raise the dock lift to unload the night locks before you can pull out the retaining pins.

Generic manual for reference only. Contact Pentalift with Product serial number to receive owners manual for your specific equipment.

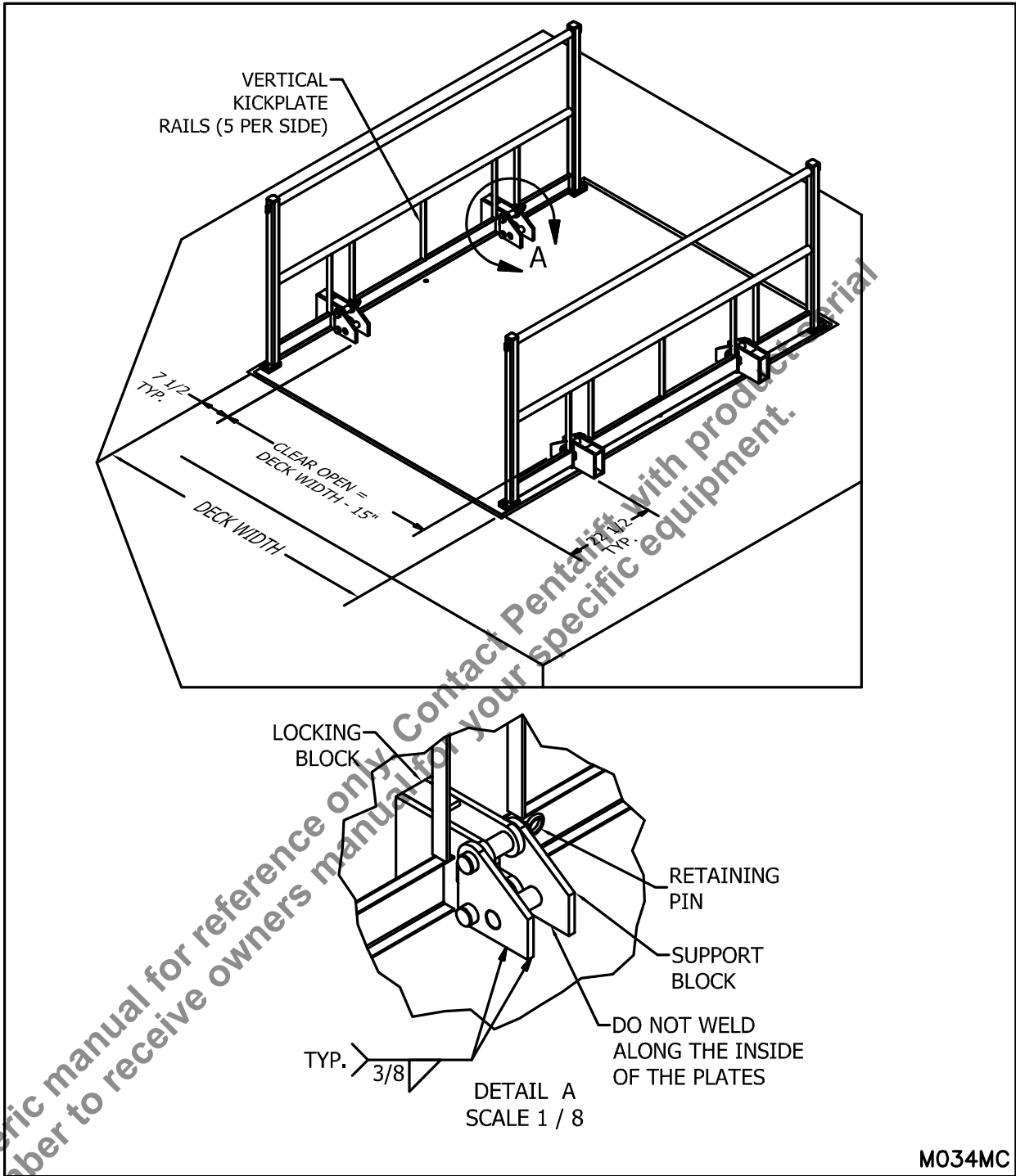

Figure 24: Night Locks Installation

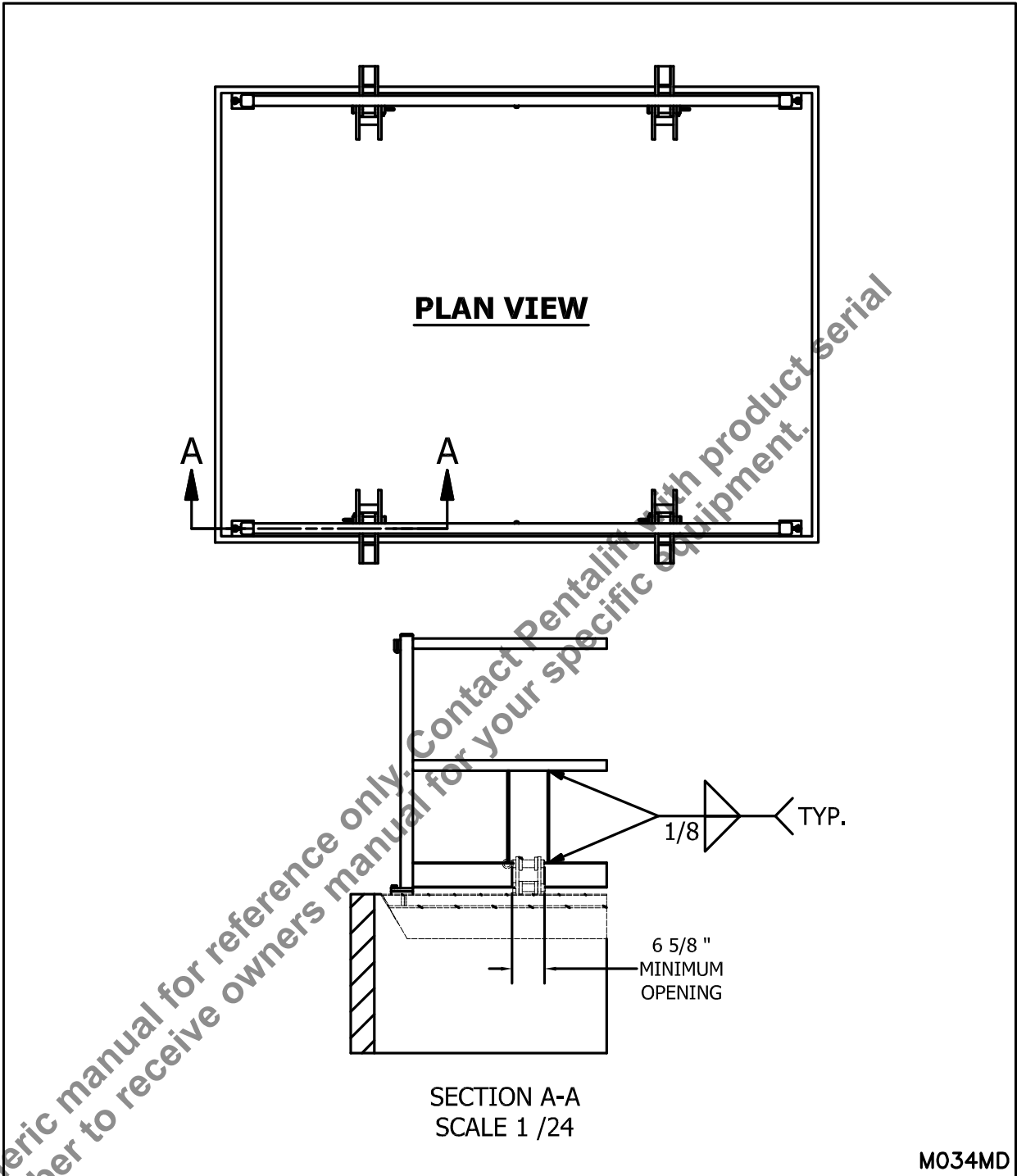

Figure 25: Night Locks Installation - Guardrails

BREAK-IN AND PERFORMANCE CHECK

DANGER

BEFORE DOING ANY INSTALLATION, MAINTENANCE, INSPECTION OR TROUBLE SHOOTING, BARRICADE ALL AREAS FROM TRAFFIC AROUND THE WORK AREA INSIDE (& OUTSIDE IF APPLICABLE) FOR SAFETY, POST APPROPRIATE WARNING SIGNS AND BE CERTAIN THAT THE POWER IS DISCONNECTED, PROPERLY TAGGED AND LOCKED OUT. ALL ELECTRICAL WORK MUST BE PERFORMED BY A QUALIFIED ELECTRICIAN IN ACCORDANCE WITH ALL APPLICABLE CODES.

DANGER

Arc flash and shock hazard PPE (personal protection equipment) required. De-energize equipment before working on or inside. Do not open cover without appropriate PPE. Refer to NFPA 70E for PPE requirements. This panel may contain more than one power source. Hazardous voltage will cause severe injury or death.

DANGER

Before doing any electrical work, be certain that the power is disconnected with a fused disconnect, properly tagged and locked out. Fused disconnect and lockout device (supplied and installed by others) must meet with all applicable codes and regulations. All electrical work must be performed by a qualified electrician in accordance with all applicable codes and regulations.

DANGER

NEVER GO BENEATH THE DOCK LIFT FOR ANY REASON UNLESS THE PLATFORM AND HINGED BRIDGE(S) ARE PROPERLY SUPPORTED (See “Figure 17: How to Support the Dock Lift for Maintenance” on page 32) AND THE POWER IS DISCONNECTED, PROPERLY TAGGED AND LOCKED OUT. IT IS THE RESPONSIBILITY OF THE OWNER TO ENSURE THAT NO LOAD OR TRAFFIC IS PLACED ON THE PLATFORM WHILE THE MAINTENANCE STAND IS ENGAGED. THE CONSTRUCTION OF THE MAINTENANCE STAND IS INTENDED TO SUPPORT THE WEIGHT OF THE UNLOADED DOCK LIFT ONLY.

NOTE: IN SOME CASES THERE IS A CONSIDERABLE AMOUNT OF TIME BETWEEN THE SHIPMENT DATE AND USE OF YOUR DOCK LIFT. THIS INITIAL BREAK-IN AND PERFORMANCE CHECK SHOULD BE PERFORMED BEFORE YOU BEGIN REGULAR USE OF YOUR DOCK LIFT TO ENSURE THAT IT IS OPERATING PROPERLY.

NOTE: Read the SAFETY INFORMATION AND WARNINGS before operating the dock leveler. (See page ii)

1. Ensure that any specified interlocks (e.g. overhead doors, restraints) are fully functional.
2. It is important to purge air from the hydraulic system. To do this, raise the unit to its maximum raised height and allow the power unit to run for a minimum of 30 seconds additional time. Fully lower the unit. Discontinue use of the unit for 20 minutes to allow air to dissipate from the oil in the reservoir.

NOTE: Units equipped with an up travel limit switch will not reach their “maximum raised height” unless the limit switch is removed. The up travel limit switch must be removed to purge the air. **DO NOT remove the up travel limit switch until first ensuring there are no obstructions in the operating path of the equipment.** After the air has been purged, lower the dock lift to its desired raised height and reinstall the limit switch.

3. Raise the dock lift and install the maintenance stand as outlined on page 32.
4. Inspect hydraulic system for leaks, especially at fittings and hose connections.
5. Dock lifts do not require lubrication of the pivot points. For ease of maintenance, lifetime lubricated bushings have been used on all rollers, leg pivot points as well as the upper cylinder pivot. However, units installed outdoors or in wet and dirty environments should be lubricated. See the Maintenance and Lubrication Section, page 33.
6. Ensure the toe sensor (if equipped) is functional.

NOTE: The toe sensor option is an electrical safety device with an actuator suspended beneath the platform which halts downward travel of the dock lift if it contacts with an obstruction.

NOTE: This feature is not functional in the event of hydraulic failure.

7. Completely raise and lower the dock lift three times.

WARNING

As the performance test is being conducted, watch closely for any signs that the dock lift might not be operating properly. If you are in doubt, refer to Operating Instructions on page 30 and Troubleshooting Guide on page 37 or contact your Pentlift representative.

OPERATING INSTRUCTIONS

DANGER

USE BY UNTRAINED PEOPLE CAN RESULT IN PROPERTY DAMAGE, BODILY INJURY OR DEATH. READ, KNOW, AND OBEY ALL OPERATING INSTRUCTIONS AND SAFETY INFORMATION. FOLLOW ALL OSHA REGULATIONS REGARDING THE USE OF THIS EQUIPMENT. DO NOT USE THE DOCK LIFT IF ANY PART OF IT LOOKS BROKEN OR IF IT DOES NOT SEEM TO OPERATE PROPERLY. IF REPAIRS ARE NEEDED, CONTACT YOUR PENTALIFT REPRESENTATIVE.

DANGER

Do not install, operate or service this product unless you have read and fully understand the entire contents of this manual. Failure to do so may result in property damage, bodily injury or death.

NOTE: Read the SAFETY INFORMATION AND WARNINGS before operating the dock lift. (See page ii)

1. **NEVER EXCEED THE MAXIMUM RATED CAPACITY OF THE DOCK LIFT.** (i.e. The maximum load for a 3,000 lb. rated unit is 3,000 lb. with the load center at the center of the platform.) Typically, the single axle load capacity across the ends is 75% of the rated capacity. The single axle load across the sides is 50% of the rated capacity. Refer to the specification plate (See "Figure 2: Safety Label and Decal Locations" on page 3) for each dock lift's particular rating.

NOTE: The load is defined as the entire weight applied to the platform of the dock lift including all loading/unloading equipment, etc. If you are unsure in any way as to the suitability of this product to your application, consult a Pentalift representative prior to using the dock lift.

THE DEFINITION OF RATING, END/SIDE AXLE LOAD CAPACITIES: The maximum amount of single axle load (in the case of rolling loads) which can be applied to the loading edge of the platform (end or side) when the lift is in any raised position. This rating considers: 1) that some amount of deflection will occur during load transfer, 2) the moving and impact forces imposed by the load, 3) that this is a temporary condition during load transfer only, and 4) that the scissors lift platform is static and non-moving.

THE DEFINITION OF RATING, END/SIDE EDGE LOAD CAPACITIES: The maximum amount of static load that can be applied to the edge of the platform (end or side) when the lift is in any raised position. This rating considers: 1) that some amount of deflection will occur during load transfer, 2) that this is a temporary condition during load transfer only, and 3) that the scissors lift platform is static and non-moving.

2. Do not apply shock loads to the unit. (i.e. Do not drop loads onto the platform, lower loads onto the platform at a high rate of speed, stop unit abruptly or jog in lower range of travel.) Do not load or unload the dock lift while it is in motion. Properly secure all loads.
3. Keep any obstructions and personnel clear of the dock lift and load and their operating path to eliminate injury and/or damage. Avoid or eliminate any and all potential pinch points.
4. Prior to each use, ensure dock lift and load does not create pinch points during operation when located adjacent to or near other equipment or structures.
5. Never use the unit for lifting personnel unless it has been suitably designed and manufactured for that purpose by Pentalift Equipment Corporation. Guard rails and access chains must be used.
6. The platform surface must be kept clean and free from oil, debris, etc. Keep debris, etc. from underneath the unit.
7. When not in use, the platform should be in the lowered position with the hinged bridge(s) in an upright vertically stored position with the hinged bridge chain(s) engaged. (See "Figure 16: Hinged Bridge in Vertically Stored Position" on page 31 and "Figure 15: Hinged Bridge Not Properly Secured (See Figure 16)" on page 31).

WARNING

Prior to placing any load on the hinged bridge(s), the hinged bridge(s) must be properly supported by a surface suitable of supporting the minimum of the equivalent of the rated capacity of the lift for the entire width of the hinged bridge (for example: TRUCK BED, FACILITY FLOOR OR FACILITY DRIVEWAY). A minimum of 4 inches hinged bridge penetration is required to be at all times. (See "Figure 14: Hinged Bridge must Extend a Minimum of 4" onto the Truck Bed" on page 31) The hinge stop and hinged bridge chains **are not** intended to support any weight in addition to the unload hinged bridge(s). No loads are

to be placed on the hinged bridges when they are positioned by the hinged bridge chains and/or the hinged bridge hinge stops and not properly supported.

8. To raise the dock lift, ensure the hinged bridge(s) are in the vertically stored position. Push and hold the "UP" button. Allow the dock lift to rise to the desired height and then release the button.
9. Carefully lower the hinged bridge(s) onto the truck bed.
10. To lower the dock lift, return the hinged bridge(s) to the vertically stored position. Push and hold the "DOWN" button and the unit will descend to its lowered position.

NOTE: Push-button requires maintained contact in either raising or lowering mode. The dock lift movement may be halted at any time by releasing the push-button.

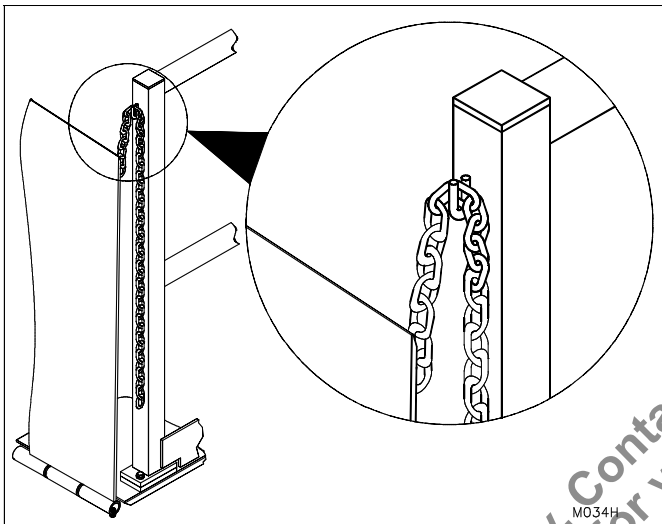

Figure 16: Hinged Bridge in Vertically Stored Position

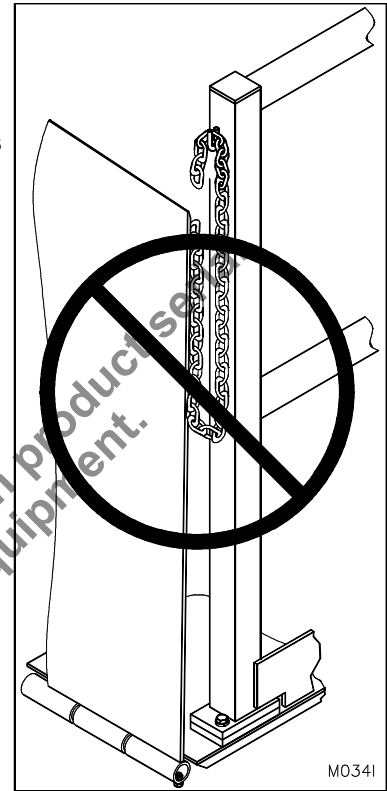

Figure 15: Hinged Bridge Not Properly Secured (See Figure 16)

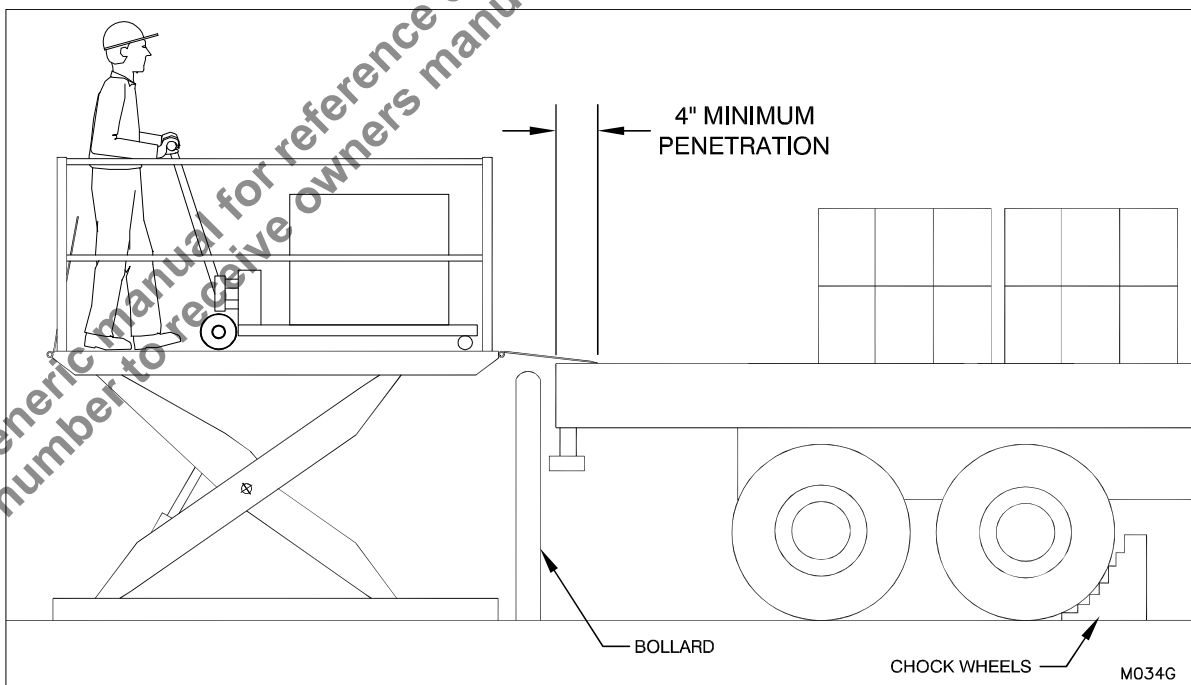

Figure 14: Hinged Bridge must Extend a Minimum of 4" onto the Truck Bed

HOW TO SUPPORT THE DOCK LIFT DURING ROUTINE MAINTENANCE AND INSPECTION

! DANGER

THE BLOCKING PROCEDURES DESCRIBED BELOW ARE SUITABLE ONLY FOR THE INSPECTION, TROUBLE SHOOTING AND MAINTENANCE PROCEDURES DESCRIBED IN THIS MANUAL. THEY MAY NOT BE SAFE FOR OTHER INSPECTION, MAINTENANCE AND REPAIR PROCEDURES THAT MAY BE REQUIRED. CONTACT YOUR AUTHORIZED PENTALIFT REPRESENTATIVE FOR DIRECTION PRIOR TO UNDERTAKING ANY ACTIONS OTHER THAN THOSE DESCRIBED IN THIS MANUAL. FAILURE TO PROPERLY ADHERE TO LIFT BLOCKING PROCEDURES IS TO RISK THE SUDDEN AND UNCONTROLLED DESCENT OF THE LIFT DURING MAINTENANCE OR INSPECTION. A FALLING LIFT CAN CAUSE SEVERE INJURY OR DEATH.

! DANGER

ONLY TRAINED AND QUALIFIED PERSONNEL SHALL PERFORM INSPECTION OR MAINTENANCE AND SERVICE PROCEDURES.

! DANGER

BEFORE DOING ANY INSTALLATION, MAINTENANCE, INSPECTION OR TROUBLE SHOOTING, BARRICADE ALL AREAS FROM TRAFFIC AROUND THE WORK AREA INSIDE (& OUTSIDE IF APPLICABLE) FOR SAFETY, POST APPROPRIATE WARNING SIGNS AND BE CERTAIN THAT THE POWER IS DISCONNECTED, PROPERLY TAGGED AND LOCKED OUT. ALL ELECTRICAL WORK MUST BE PERFORMED BY A QUALIFIED ELECTRICIAN IN ACCORDANCE WITH ALL APPLICABLE CODES AND REGULATIONS.

! DANGER

Arc flash and shock hazard PPE (personal protection equipment) required. De-energize equipment before working on or inside. Do not open cover without appropriate PPE. Refer to NFPA 70E for PPE requirements. This panel may contain more than one power source. Hazardous voltage will cause severe injury or death.

! DANGER

PRIOR TO PERFORMING ANY ACTIVITY WITHIN THE OPERATING PATH OF THE DOCK LIFT, ALWAYS ENSURE THAT THERE IS NO LOAD ON THE DOCK LIFT AND THAT THE INSTRUCTIONS LISTED BELOW ARE FOLLOWED.

! DANGER

NEVER GO BENEATH THE DOCK LIFT FOR ANY REASON UNLESS THE PLATFORM AND HINGED BRIDGE(S) ARE PROPERLY SUPPORTED (SEE "Figure 17: How to Support the Dock Lift for Maintenance" on page 32) AND THE POWER IS DISCONNECTED, PROPERLY TAGGED AND LOCKED OUT. IT IS THE RESPONSIBILITY OF THE OWNER TO ENSURE THAT NO LOAD OR TRAFFIC IS PLACED ON THE PLATFORM WHILE THE MAINTENANCE STAND IS ENGAGED. THE CONSTRUCTION OF THE MAINTENANCE STAND IS INTENDED TO SUPPORT THE WEIGHT OF THE UNLOADED DOCK LIFT ONLY.

NOTE: ANY LOADS INCLUDING LOADING/UNLOADING EQUIPMENT, ETC., ARE TO BE REMOVED.

The blocking procedure is as follows:

1. Raise the unloaded dock lift to its maximum height.
2. Insert the drop-in style maintenance stand at the rolling end of the dock lift into the path of the rollers, or use the swing away maintenance stand pivots on a pin (only one of these maintenance stand configurations will be supplied). Swing the maintenance stand as far around as possible into the path of the rollers. (See "Figure 17: How to Support the Dock Lift for Maintenance" on page 32)

! DANGER

If your unit is equipped with TWO swing away maintenance stands, one on each side of the dock lift frame, use both maintenance stands simultaneously.

3. Lower the dock lift until the leg rollers are securely supported by the maintenance stand(s). Confirm the scissor legs are now securely blocked from downward movement.
4. Disconnect, properly tag and lock out power to the dock lift prior to commencing inspection, trouble shooting or maintenance.

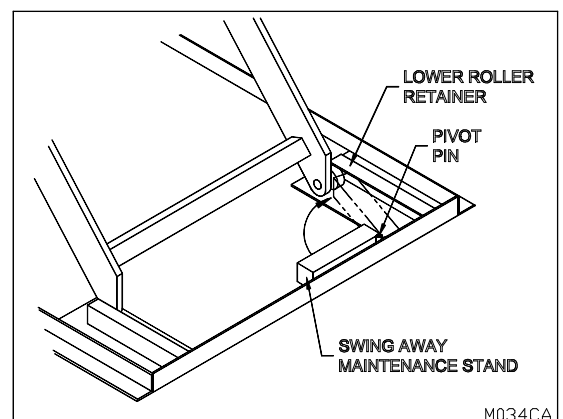

Figure 17: How to Support the Dock Lift for Maintenance

MAINTENANCE AND LUBRICATION

UNLESS OTHERWISE NOTED, THE FOLLOWING MAINTENANCE AND INSPECTION PROCEDURES SHOULD BE CONDUCTED AT A MINIMUM OF EVERY 30 DAYS. INCREASE FREQUENCY FOR MORE SEVERE ENVIRONMENTS.



ONLY TRAINED AND QUALIFIED PERSONNEL SHALL PERFORM INSPECTION OR MAINTENANCE AND SERVICE PROCEDURES. FOLLOW ALL WARNINGS IN THE SAFETY INFORMATION AND WARNINGS SECTION OF THIS MANUAL.



Arc flash and shock hazard PPE (personal protection equipment) required. De-energize equipment before working on or inside. Do not open cover without appropriate PPE. Refer to NFPA 70E for PPE requirements. This panel may contain more than one power source. Hazardous voltage will cause severe injury or death.



NEVER GO BENEATH THE DOCK LIFT FOR ANY REASON UNLESS IT IS PROPERLY SUPPORTED (SEE HOW TO SUPPORT THE DOCK LIFT... on page 32), THE INSIDE (AND OUTSIDE IF APPLICABLE) WORK AREAS ARE BARRICADED FOR SAFETY, APPROPRIATE WARNING SIGNS ARE POSTED AND THE POWER IS DISCONNECTED, PROPERLY TAGGED AND LOCKED OUT. IT IS THE RESPONSIBILITY OF THE OWNER TO ENSURE THAT NO LOAD EXISTS ON THE DECK WHILE THE MAINTENANCE STAND IS ENGAGED. THE CONSTRUCTION OF THE MAINTENANCE STAND IS INTENDED TO SUPPORT THE WEIGHT OF THE UNLOADED DOCK LIFT ONLY.



THE RELIEF VALVE ON THE POWER UNIT IS PRESET AT THE FACTORY. IT IS AN IMPORTANT SAFETY DEVICE. DO NOT ADJUST OR REMOVE THE RELIEF VALVE.



BE SURE ALL HYDRAULIC FITTINGS ARE RATED FOR HYDRAULIC SYSTEMS THAT MAY PEAK OUT AT 4000PSI. HARDWARE STORE ITEMS CAN BURST AT 150PSI. ONLY BUY REPLACEMENT PARTS FROM PENTALIFT.

NOTE: Read the SAFETY INFORMATION AND WARNINGS before servicing the dock lift. (See page II)

NOTE: It is the owner's responsibility to ensure that all labeling remains legible and in its original position throughout the life of the product. (See "SAFETY LABELING" on page 2)

NOTE: Inspect equipment for protective coatings (i.e. paint) that have deteriorated or been removed. Prepare affected area and reapply protective coating as required.

NOTE: At every maintenance interval, inspect the dock lift for any damage or worn parts. If any damaged or worn parts are found, discontinue use of the dock lift and/or repair immediately.



Be sure the maintenance stand is properly engaged before performing maintenance checks 2 through 6 or reaching beneath a raised lift. (See "HOW TO SUPPORT THE DOCK LIFT DURING ROUTINE MAINTENANCE AND INSPECTION" on page 32).

1. Clean all debris from the pit or the vicinity of floor mounted units in order to avoid interference with the lift mechanism or rollers.
2. Check for presence and proper seating of all spring pins on all axles, cylinders and rollers. Confirm that all welds on the spring pin collars are intact (See "Figure 18: Spring Pins" on page 34).
3. Check rollers, pins and bushings for any signs of wear such as flat spots, missing fasteners, or dislodged bearing material.
4. Check the hydraulic fittings for cracks or leaks and clean up any seepage on or beneath the cylinders.
5. Check hoses and electrical lines for abrasions or other abuse and check for snug connections.
6. Operate the unit and check for any abnormal noise or vibrations.
7. Check all safety devices on the unit such as handrails, access chains, etc. including any options such as toe sensor and hydraulic hinged bridges, for proper operation.

8. Check the hinged bridge to ensure that its stops are not damaged, allowing it to droop more than 45 degrees below horizontal, check the hinge spools for cracks and or broken welds.

Ensure that any specified interlocks (e.g. overhead doors, restraints) are fully functional.

Ensure the toe sensor (if equipped) is functional by raising the lift to full height and lifting the toe sensor bar under each of the toe sensor limit switches (there are normally 4 switches). Confirm the unit does not lower with the toe sensor bar raised. Repeat the lifting on each of the limit switches and confirm the unit will not lower when the bar is lifted under any of the switches. **NOTE:** The toe sensor option is an electrical safety device with an actuator suspended beneath the platform which halts downward travel of the dock lift if it contacts with an obstruction. (This feature is not functional in the event of hydraulic failure.)

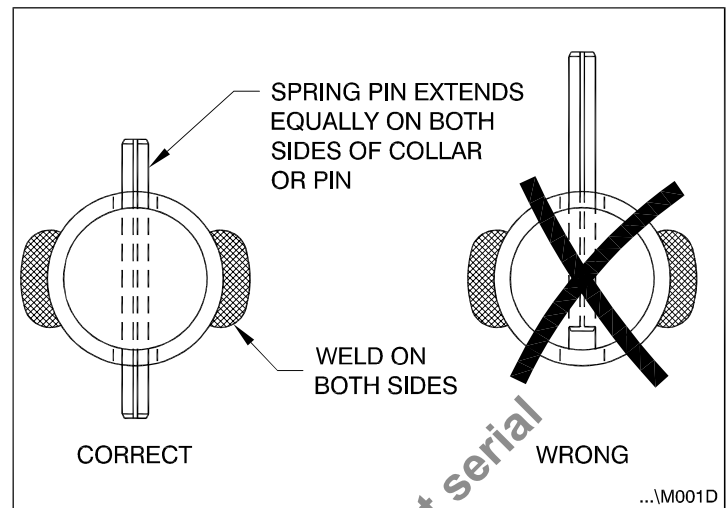

Figure 18: Spring Pins

Hydraulic Oil:

Weekly: Once a week, or after repetitive operation, the lift should be raised to its full height. This will get rid of cylinder oil seepage build-up and lubricate the upper cylinder barrel.

Monthly: For ease of maintenance, lifetime lubricated bushings have been used on all rollers, leg pivot points as well as the upper cylinder pivot. However, units installed outdoors or in wet and dirty environments should be lubricated regularly at the points indicated in “Figure 19: Lubrication Oil and Grease Points” on page 35. The recommended lubrication **service interval is every 30 days** or at a greater frequency as required in severe environments. **HVI-22** is the recommended replacement hydraulic fluid and EP2 Multipurpose Grease or equivalent is recommended for grease points.

The oil level should be checked once a month. When the dock lift is fully lowered, the oil level in the reservoir of a 1 or 3 hp power unit should be approximately 2 – 3 inches from the top. A 5 hp or higher power unit should have the oil in the reservoir filled to the full mark on the sight gauge. The oil should be changed once a year under normal operating conditions. If the hydraulic oil is non-standard, check the hydraulic reservoir for fluid label which will specify the particular fluid requirements. It is strongly urged that a maintenance log be maintained with the dates of monthly inspections, the name of the inspector and results of the inspection.

Seasonal or semiannual maintenance: Change hydraulic fluid for ambient temperature changes if appropriate. Check the fluid reservoir to see if there is any evidence of accumulated condensation creating water contamination. The fluid will appear “milky” and light pink in color. Water accumulation will damage the hydraulic pump.

Dock lifts also require grease at the base of the hydraulic cylinders; See “Figure 19: Lubrication Oil and Grease Points” on page 35.

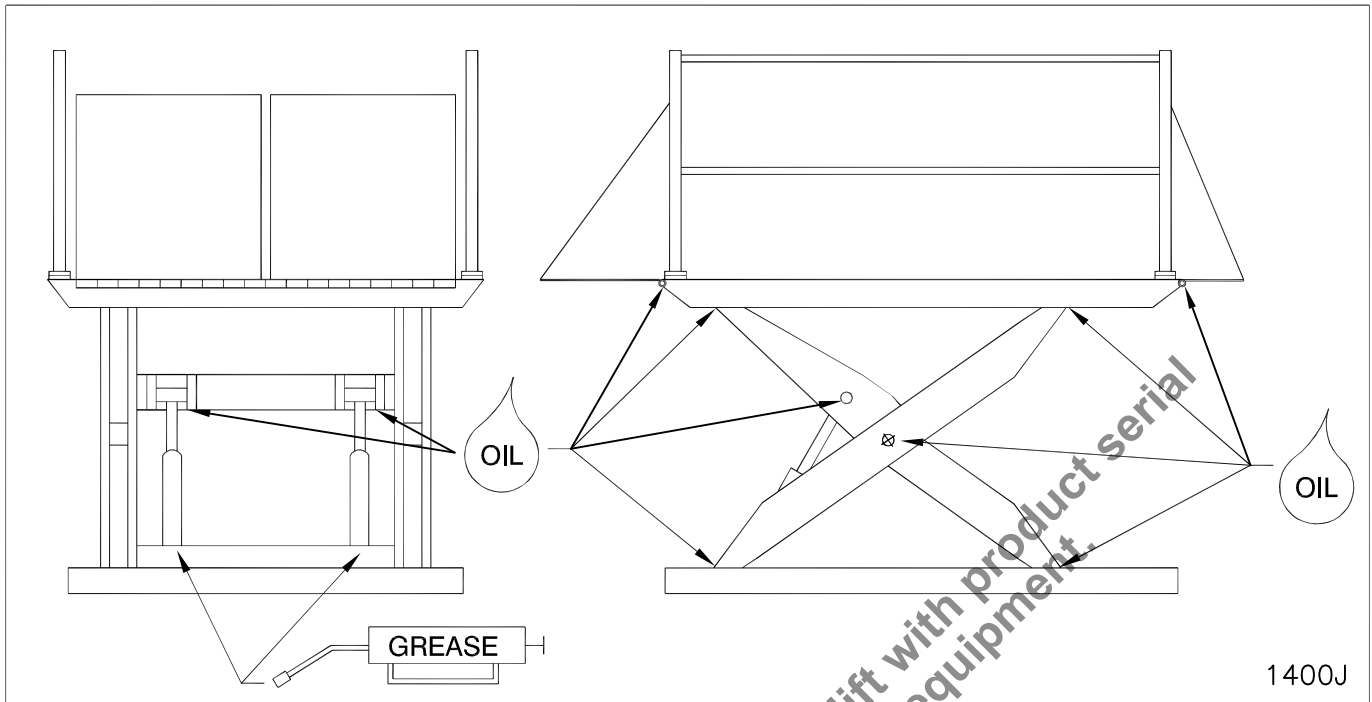

Figure 19: Lubrication Oil and Grease Points

NOTICE: HYDRAULIC FLUID

The standard hydraulic oil supplied with the equipment is HVI-22 Hydraulic fluid. This fluid is suitable for use from approximately -30° C (-22F) minimum to +35°C (+95°F) unless otherwise specified on the specific equipment order. The equipment can be operated in temperatures slightly higher and lower than the temperatures stated on an intermittent basis. Operating the equipment for extended periods of times at temperatures higher or lower than the stated temperatures above may result in functional issues for the equipment. It may also result in damage and issues to hydraulic components. As the actual temperature the equipment is used in moves further away from the recommended temperature range the concern points increase. Abuse and overuse in this regard will void all warranty.

The standard replacement Hydraulic Fluid is HVI-22 hydraulic fluid which accommodates the temperature range stated above. There are special hydraulic fluids available to accommodate temperatures that are consistently and or significantly lower or higher than those stated above. In many cases the use of these types of specialty fluids will result in the requirement for hydraulic fluid changes during seasonal yearly temperature changes.

Recommended for colder temperatures is Hydraulic Fluid 5606A
 Recommended for warmer temperatures is Hydraulic Fluid HVI-32

If the hydraulic oil provided from the factory is non-standard, refer to the hydraulic reservoir fluid label which will specify the particular oil requirements.

Note: When approaching or operating in temperature beyond the high and low temperature ranges of the ratings for the hydraulic fluids, there may be some adverse effects to the functionality of the equipment. This could include (but not be limited to) harmonics and vibration of cylinders, inhibited or reduced equipment performance and function, slower cycle times, hydraulic leaks unwanted activation of velocity fuses. To address concerns of this nature a change in hydraulic fluid or a special oil additive maybe required. Contact your Pentalift representative for more information.

Note: The remote installation location of the hydraulic power unit can also help address concerns with hydraulic fluid temperature ranges. For example if the equipment is purchased with a remote power unit, the power unit can be installed in a warmer (indoor) location. In this arrangement, even though the main equipment and it's hydraulic components maybe exposed to more extreme temperatures, the hydraulic power unit and the hydraulic fluid stored in it will be exposed to and therefore absorb the more moderate and desirable internal temperature. During operation the oil in the power unit will quickly mix with the oil in the equipment and will typically mix to a more

desirable temperature level.

Note: That if the hydraulic power unit is installed in a pit, as is usually the case for dock levelers, the pit will have moderating effect on the temperature the hydraulic power unit is exposed to. This should be part of the consideration of hydraulic fluid selection.

Generic manual for reference only. Contact Pentlift with product serial number to receive owners manual for your specific equipment.

TROUBLE SHOOTING GUIDE

NOTE: This equipment has been fully tested and confirmed to be operational at the factory. Historically, the majority of operating problems are caused by unnecessary tampering by unqualified personnel. To conform to the terms of the Warranty, contact your authorized Pentalift representative if you are having any difficulty with the dock lift during the warranty period. Do not risk voiding the warranty by tampering with the equipment.

⚠ DANGER ONLY TRAINED AND QUALIFIED PERSONNEL SHALL PERFORM INSPECTION OR MAINTENANCE AND SERVICE PROCEDURES.

⚠ DANGER BEFORE DOING ANY INSTALLATION, MAINTENANCE, INSPECTION OR TROUBLE SHOOTING, BARRICADE THE INSIDE (AND OUTSIDE IF APPLICABLE) WORK AREAS FOR SAFETY AND POST APPROPRIATE WARNING SIGNS. FOLLOW ALL WARNINGS IN THE SAFETY INFORMATION AND WARNINGS SECTION OF THIS MANUAL.

⚠ DANGER Arc flash and shock hazard PPE (personal protection equipment) required. De-energize equipment before working on or inside. Do not open cover without appropriate PPE. Refer to NFPA 70E for PPE requirements. This panel may contain more than one power source. Hazardous voltage will cause severe injury or death.

⚠ DANGER Before doing any electrical work, be certain that the power is disconnected with a fused disconnect, properly tagged and locked out. Fused disconnect and lockout device (supplied and installed by others) must meet with all applicable codes and regulations. All electrical work must be performed by a qualified electrician in accordance with all applicable codes and regulations.

⚠ DANGER NEVER GO BENEATH THE PLATFORM UNLESS THE LOAD IS REMOVED AND THE SCISSOR MECHANISM IS PROPERLY BLOCKED (SEE page 32.)

⚠ DANGER THE RELIEF VALVE ON THE POWER UNIT IS PRESET AT THE FACTORY. IT IS AN IMPORTANT SAFETY DEVICE. DO NOT ADJUST OR REMOVE THE RELIEF VALVE.

NOTICE See page 34 for recommended hydraulic oil.

1. Dock lift will not rise when the push button is depressed.

- Re-check all wiring and hydraulic connections. Refer to the wiring diagram found inside the motor control panel.
- Ensure proper hydraulic fluid level. (See page 33)
- Examine all moving parts for obstructions.
- Confirm that power is reaching the power unit.
- On 3 phase units, ensure phase polarity is correct. Incorrect polarity will cause the dock lift not to rise. The motor will run backwards resulting in cavitation and possible damage to the pump.
- If the problem cannot be solved, consult your authorized Pentalift representative.

2. Motor runs, however, the dock lift does not rise.

- Ensure proper hydraulic fluid level. (See page 33)
- On 3 phase units, ensure phase polarity is correct. Incorrect polarity will cause the dock lift not to raise. The motor will run backwards resulting in cavitation and possible damage to the pump.
- Check for any obstructions.
- Check to ensure the load does not exceed the rated capacity of the dock lift.
- If the problem cannot be solved, consult your authorized Pentalift representative.

3. Breaker is disengaging or supply line fuses are burning out.

- Ensure proper voltage is reaching the motor. (See Electrical Reference Chart.)
- Check for any obstructions.
- Check all wiring connections.
- If the problem cannot be solved, consult your authorized Pentalift representative.

4. Dock lift rises or lowers with a jerking movement.

- a) Ensure proper hydraulic fluid level. (See page 33)
- b) Air may be present in the hydraulic system. (See initial set-up; Item 20, Page 14.)
- c) Check for any obstructions.
- d) Check to ensure load does not exceed rated capacity of dock lift.
- e) Ensure dock lift is shimmed properly. (See “Figure 6: Shim Beneath the Fixed End Clevises and Full Roller Travel” on page 13)
- f) If the problem cannot be solved, consult your authorized Pentalift representative.

5. Dock lift will not lower.

- a) Re check all wiring.
- b) Check for any obstructions.
- c) Ensure electrical lowering valve is energized when down button is depressed.
- d) If equipped with optional toe sensor, ensure toe sensors are not engaged. (i.e. obstruction under toe sensors, etc. See item 6, page 28 for definition of toe sensor.)
- e) If the problem cannot be solved, consult your authorized Pentalift representative.



If damaged or worn parts are detected upon inspection, replacement must be undertaken **immediately. The dock lift must not be used until replacement is completed.** Parts are readily available from your Pentalift representative.

Generic manual for reference only. Contact Pentalift with product serial number to receive owners manual for your specific equipment.

REPLACEMENT PARTS

USE ONLY GENUINE PENTALIFT REPLACEMENT PARTS



To ensure proper functioning, durability and safety of the product, only genuine pentalift replacement parts must be used. Altering the product from its original manufactured configuration must not be done. Pentlift equipment Corporation disclaims all liability for failure to comply with this warning. Warranties are specifically disclaimed in the event the purchaser fails to comply with this warning.

To expedite order processing when ordering parts, provide the following information to your Pentlift representative:

1. Model and Serial Number of equipment.
2. Part Number, Description and Quantity.
3. Shipping Instructions.

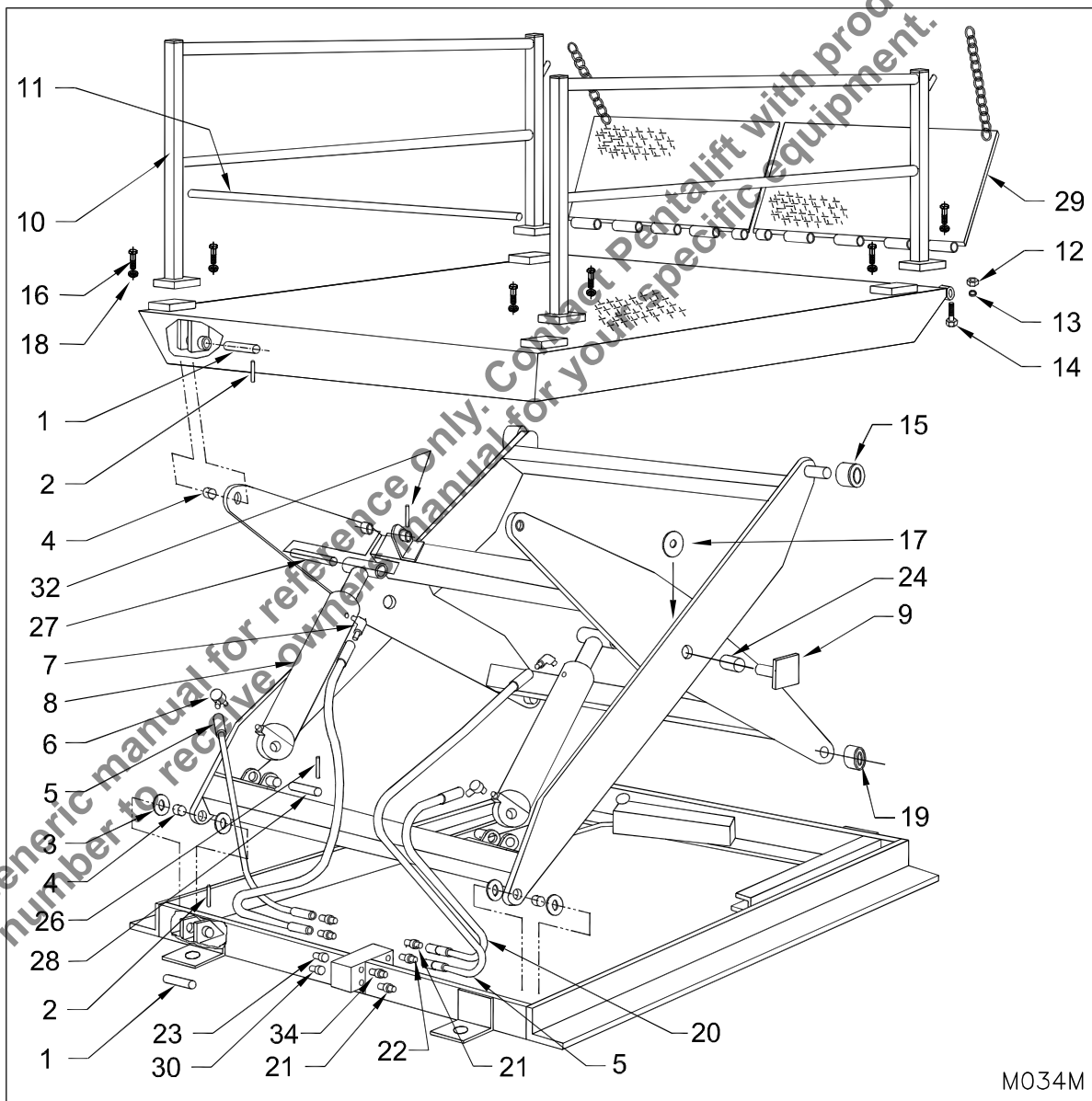

Figure 20: Replacement Parts

REPLACEMENT PARTS LIST

USE ONLY GENUINE PENTALIFT REPLACEMENT PARTS

<u>Item #</u>	<u>Part No.</u>	<u>Description</u>
1	301-0523	Fixed End Clevis Pin
2	080-0001	Spring Pin
3	074-0040	Washer
4	NOTE	Bushings (Set for upper and lower fixed end leg pivot points)
5	NOTE	Bypass Return Cylinder Hose Assembly (Specify length)
6	052-0052	Fitting
7	052-0016	Fitting
8	NOTE	Lift Cylinder
9	See Chart A	Center Pin Assembly
10	NOTE	Guard Rail
11	NOTE	Hinged Bridge Pin
12	070-0010	Nut
13	074-0076	Lock Washer
14	072-0016	Bolt
15	801-0541	Upper Roller Assembly c/w Bushing (6,000 lb. - 20,000 lb. models)
	801-0542	Upper Roller Assembly c/w Bushing (3,000 lb. - 5,000 lb. models)
16	074-0035	Bolt
17	074-0045	Spacer (3,000 lb. - 12,000 lb. models)
	301-0888	Spacer (15,000 lb. models)
18	074-0083	Lock Washer
19	801-0543	Lower Roller Assembly c/w Bushing (6,000 lb. - 20,000 lb. models)
	801-0554	Lower Roller Assembly c/w Bushing (3,000 lb. - 5,000 lb. models)
20	NOTE	Pressure Cylinder Hose Assembly
21	052-0048	Fitting
22	052-0017	Fitting
23	052-0155	Plug
24	095-0036	Center Pin Bushing (3,000 lb. - 12,000 lb. models)
25	NOTE	Flow Control (Not Shown)
26	080-0025	Spring Pin
27	See Chart C	Upper Cylinder Pin
28	301-0836	Lower Cylinder Pin
29	NOTE	Hinged Bridge
30	052-0066	Plug
31	060-0510	Toe sensor Limit Switch (Optional - Not Shown)
32	080-0025	Spring Pin
33	NOTE	Velocity Fuse (Optional - Not Shown)
34	052-0085	Fitting

NOTE: State Model # and Serial # when ordering replacement parts.

REPLACEMENT PARTS LIST- CHARTS

USE ONLY GENUINE PENTALIFT REPLACEMENT PARTS

CHART A

ITEM #10- CENTER PIN ASSEMBLY

801-0535	For Models with 3/4" Thick Legs
801-0536	For Models with 1" Thick Legs
801-0537	For Models with 1 1/4" Thick Legs
801-0568	For Models with 1 1/2" Thick Legs

CHART B

ITEM #21- LOWER ROLLER PIN ASSEMBLY

801-0545	For Models with 3/4" Thick Legs
801-0546	For Models with 1" Thick Legs
801-0547	For Models with 1 1/4" Thick Legs
801-0548	For Models with 1 1/2" Thick Legs

CHART C

ITEM #30- UPPER CYLINDER PIN

301-0834	For Models with 3/4" Thick Legs
301-0834	For Models with 1" Thick Legs
301-0834	For Models with 1 1/4" Thick Legs
301-0809	For Models with 1 1/2" Thick Legs & Dual Cylinders

LIFT CYLINDER REPLACEMENT PARTS

USE ONLY GENUINE PENTALIFT REPLACEMENT PARTS

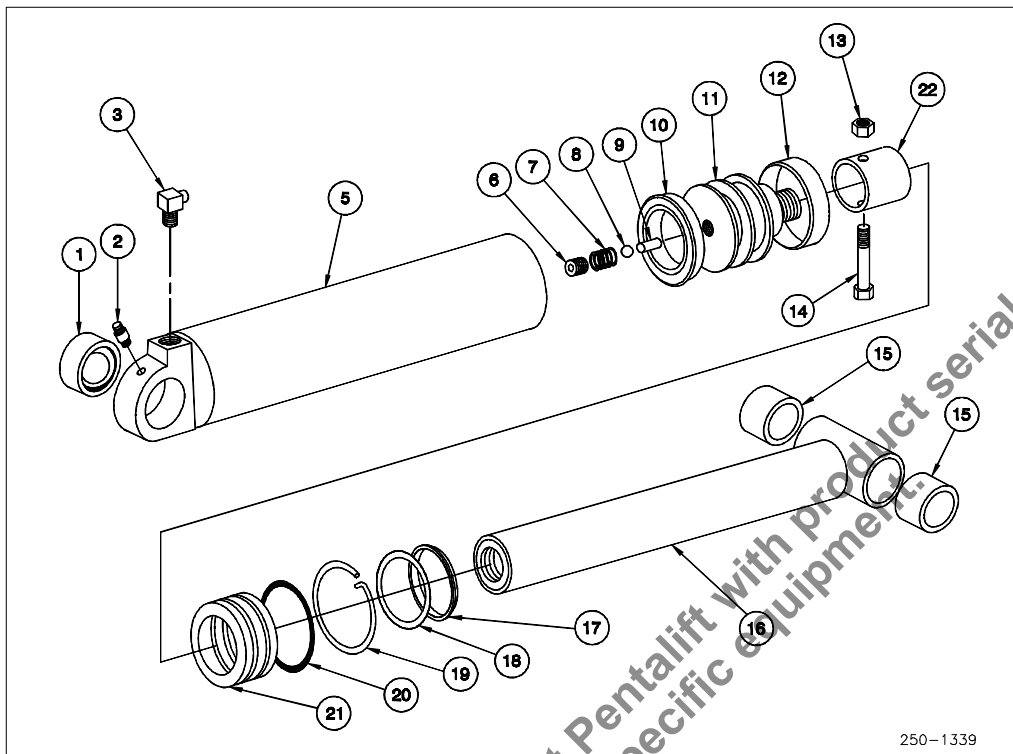

Figure 21: Cylinder Replacement Parts

<u>Item #</u>	<u>Description</u>	<u>Part # for 4" OD (3 1/2" ID)</u>	<u>Part # for 4 1/2" OD (4" ID)</u>
1	Swivel Bearing	090-0011	090-0011
2	Grease Fitting	052-0170	052-0170
3	90 Degree Fitting	052-0052	052-0052
5	Cylinder Housing Assembly	----	----
6	*Set Screw	250-1879	250-1879
7	*Spring	097-0020	097-0020
8	*Ball	090-0001	090-0001
9	*By-Pass Pin	300-4001	300-4001
10	*U Cup	054-0501	054-0502
11	Cartridge	300-0883	300-0888
12	*Wear Ring	054-0521	054-0522
13	Nut	070-0060	070-0060
14	Bolt	072-0044	072-0044
15	Bushing	095-0015	095-0015
16	Piston Rod Assembly	----	----
17	*Wiper	054-0504	054-0504
18	*Inner "O" Ring	054-0329	054-0329
19	*Retaining Ring	300-0088	300-0203
20	*Outer "O" Ring	054-0338	054-0342
21	Head Nut	300-0000	300-0001
22	Dump Tube	NOTE	NOTE
23	Seal Kit- Includes all items marked with *	800-0284	800-0316
24	Replacement Cylinder (Items 1- 22)	NOTE	NOTE

NOTE: State Model # and Serial # when ordering replacement parts.

LIST OF ILLUSTRATIONS

Figure 1: Safety Labels and Decals	2
Figure 2: Safety Label and Decal Locations	3
Figure 3: Moving the Dock Lift	5
Figure 4: Connect the Hoses to Junction Block on Side Nearest to the Power Unit.....	5
Figure 5: Square the Dock Lift in the Pit	12
Figure 6: Shim Beneath the Fixed End Clevises and Full Roller Travel	13
Figure 7: Guard Rail Installation.....	15
Figure 8: Three Sided Pit Potential Pinch Points	16
Figure 9: Guard Rails with Mesh Side Covering	17
Figure 10: Guard Rails Mounted on Dock Floor	17
Figure 11: Limit Switch Position.....	19
Figure 12: Switch & Actuator Bracket Side View.....	19
Figure 13: Operation of Switch	20
Figure 14: Hinged Bridge must Extend a Minimum of 4” onto the Truck Bed.....	31
Figure 15: Hinged Bridge Not Properly Secured (See Figure 16).....	31
Figure 16: Hinged Bridge in Vertically Stored Position	31
Figure 17: How to Support the Dock Lift for Maintenance.....	32
Figure 18: Spring Pins	34
Figure 19: Lubrication Oil and Grease Points	35
Figure 20: Replacement Parts	39
Figure 21: Cylinder Replacement Parts	42
Figure 22: Hydraulic Hinged Bridge Assist.....	22
Figure 23: Option#1 - Routing of Power Cord.....	24
Figure 24: Night Locks Installation.....	27
Figure 24: Option#2 - Routing of Power Cord	25
Figure 25: Night Locks Installation - Guardrails	28
Figure 26: Floor Mounted Remote Power Unit	7
Figure 27: Wall Mounted Remote Power Unit	8
Figure 28: Lag Bracket and Wedge Anchor Configurations.....	14
Figure 29: Lifting Bar for narrow hinged bridge	23

Generic manual for reference only. Contact Pentalift with product serial number to receive owners manual for your specific equipment.

PENTALIFT EQUIPMENT CORPORATION WARRANTY

WARRANTY

Pentalift Equipment Corporation expressly warrants that any product manufactured by **Pentalift Equipment Corporation** will be free from defects in material and workmanship under normal use for a period of one (1) year from the date of shipment of the equipment, provided the original purchaser maintains and operates the product in accordance with proper procedures. In the event the product proves defective in material or workmanship, **Pentalift Equipment Corporation** will at its option:

1. Replace the product or the defective portion thereof without charge to the purchaser; or
2. Alter or repair the product; on site or elsewhere, as **Pentalift Equipment Corporation** may deem advisable, without charge to the purchaser.

The warranty stated in the previous paragraph is that expressed by **PENTALIFT EQUIPMENT CORPORATION** AND IS IN LIEU OF ALL GUARANTEES AND WARRANTIES, EXPRESSED OR IMPLIED BY ANYONE OTHER THAN **PENTALIFT EQUIPMENT CORPORATION**. This warranty does not cover any failure caused by improper installation, misapplication, overloading, abuse, negligence, or failure to lubricate and adjust or maintain the equipment properly and regularly. Parts requiring replacement due to damage resulting from abuse, improper operations, improper or insufficient lubrication, lack of proper protection or vehicle impact are not covered by this warranty. **Pentalift Equipment Corporation** assumes no responsibility or liability for:

1. Consequential damages of any kind which result from use or misuse of the equipment.
2. Damage or failure resulting from the use of unauthorized replacement parts.
3. Damage or failure resulting from modification of the equipment.
4. Damage resulting from the misuse of the equipment.

THERE ARE NO WARRANTIES, EXPRESSED OR IMPLIED, WHICH EXTEND BEYOND THE DESCRIPTION ON THE FACE HEREOF, AND THERE IS NO WARRANTY OF MERCHANTABILITY OR OF FITNESS FOR A PARTICULAR PURPOSE.

Pentalift Equipment Corporation warranties extend only to the original product itself. In no event shall **Pentalift Equipment Corporation** be responsible for or liable to anyone, including third parties, for special, indirect, collateral, punitive, incidental or consequential damages, even if **Pentalift Equipment Corporation** has been advised of the possibility of such damages. Such excluded damages include, but are not limited to, loss of good will, loss of profits, loss of use, interruption of business or other similar indirect financial loss.

Pentalift Equipment Corporation DISCLAIMS all liability arising out of the workmanship, methods and materials used by the installer.

Pentalift Equipment Corporation DISCLAIMS all liability for premature product wear, product failure, property damage or bodily injury arising from improper installation and application.

Pentalift Equipment Corporation will not accept any warranty for which the original purchaser does not notify **Pentalift Equipment Corporation's** Warranty Department of the defect within ninety (90) days after the product defect is discovered. A fully completed Product Registration Card is required prior to the review or processing of any warranty requests or claims.

WARRANTIES, whether expressed or implied, relating to workmanship and materials used in connection with the installation of **Pentalift Equipment Corporation** products are specifically DISCLAIMED.

WR001R02



P.O. Box 1510, Buffalo, NY, U.S.A. 14240-1510
Phone: (519) 763-3625 □ FAX (519) 763-2894
21 Nicholas Beaver Rd, Puslinch, Ontario, N0B 2J0 Canada
Phone: (519) 763-3625 □ FAX (519) 763-2894

NOTE: All Pentalift Equipment Corporation products are subject to design improvement through modification without notice.