



PENTALIFT EQUIPMENT CORPORATION

HYDRAULIC EDGE OF DOCK OWNERS MANUAL

MODEL NUMBER : _____ **SERIAL NUMBER :** _____

CAPACITY : _____

Individual Model Number(s) and Serial Number(s) must be filled out by the user for future reference.

This manual is an important document.

It shall be kept with the machine or located where readily available to operators and maintenance personnel for reference purposes. Do not install, operate or service this product unless you have read and fully understand the entire contents of this manual. Failure to do so may result in property damage, bodily injury or death. Keep this manual in a safe place for future reference.

**Pentalift Equipment Corporation
21 Nicholas Beaver Rd
Puslinch, ON N0B 2J0
Phone: 519-763-3625
Fax: 519-763-2894
Parts Phone: 519-763-3625 Extension 625
Ask for Parts Department**

Pentalift Equipment Corporation provides an owners manual when equipment is shipped. Additional manuals are available at \$25.00 each.

IMPORTANT: The owners manuals that are provided on Pentalift Equipment Corporations website are generic in nature. They are provided for general information only. For all purposes, only the owners manual that is specific to the equipment should be referenced and relied on. In order to receive the specific owners manual for specific Pentalift equipment, please contact your Pentalift representative and supply the specific serial number(s) for the equipment the manual is required for. Do not rely on the information in the generic owners manuals provided through the website as it may not be appropriate for your specific Pentalift equipment.

PRODUCT REGISTRATION



PRODUCT REGISTRATION CARD

To validate warranty and to advise of product updates please complete the following information and return to
Pentalift Equipment Corporation

To validate warranty on-line go to: www.pentalift.com

END USER INFORMATION

*Company Name:		
Contact *First Name:	*Last Name:	Title:
*Mailing Address:		
*City:	*State/Prov.	*Zip/Postal Code:
*Phone: () -	Fax: () -	Email:
Check Products Purchased:	<input type="checkbox"/> Levelers, <input type="checkbox"/> Vehicle Restraints, <input type="checkbox"/> Seals/Shelters, <input type="checkbox"/> Elevating Docks, <input type="checkbox"/> Lift Tables	
*Serial Number(s):	Invoice # (if available):	
Dealer Name:	Sales Rep.:	
Manual Verification	*Manual Number:	

Please return to:

Pentalift Equipment Corporation
P.O. Box 1510,
Buffalo, NY 14240-1510

or

Pentalift Equipment Corporation
21 Nicholas Beaver Rd
Puslinch, Ontario
N0B 2J0

Attention: Service Department

Or Fax to (519) 763-2894

SAFETY INFORMATION AND WARNINGS



READ THESE SAFETY PRACTICES BEFORE INSTALLING, OPERATING OR SERVICING THE HYDRAULIC EDGE OF DOCK. FAILURE TO FOLLOW THESE SAFETY PRACTICES MAY RESULT IN PROPERTY DAMAGE, BODILY INJURY OR DEATH.

THE OPERATION OF THIS EQUIPMENT IS SUBJECT TO CERTAIN HAZARDS THAT CAN BE PROTECTED AGAINST ONLY BY THE EXERCISE OF CARE AND COMMON SENSE AND NOT BY MECHANICAL MEANS. IT IS, THEREFORE, ESSENTIAL TO HAVE COMPETENT, QUALIFIED OPERATORS TRAINED IN THE SAFE OPERATION AND CARE OF THIS TYPE OF EQUIPMENT. ALL PERSONNEL MUST COMPLETELY UNDERSTAND THIS SAFETY INFORMATION BEFORE WORKING ON OR NEAR THIS EQUIPMENT.



DANGER indicates an imminently hazardous situation which, if not avoided, will result in death or serious injury.



WARNING indicates a potentially hazardous situation which, if not avoided, could result in death or serious injury.



CAUTION, used with the safety alert symbol, indicates a potentially hazardous situation which, if not avoided, could result in minor or moderate injury.

NOTICE

NOTICE is used to address practices not related to personal injury.



EDGE OF DOCK CAPACITY: THE RATED CAPACITY OF THE EDGE OF DOCK AS STATED ON THE SERIAL NUMBER PLATE IS A STATIC RATING. NUMEROUS DYNAMIC LOADING FACTORS RESULT IN THE GROSS LOAD CAPACITY (ROLLOVER CAPACITY) BEING SIGNIFICANTLY LESS THAN THE RATED STATIC CAPACITY OF THE EDGE OF DOCK. FACTORS WHICH EFFECT THE ROLL OVER CAPACITY ARE: WEIGHT OF THE LOAD; WEIGHT OF THE FORK TRUCK; SPEED OF THE FORK TRUCK AS IT ROLLS OVER THE EDGE OF DOCK; INCLINE OR DECLINE SLOPE OF THE EDGE OF DOCK DECK AND LIP WHEN IN USE; FREQUENCY OF USE; AND DESIRED LIFE OF THE EDGE OF DOCK. PRIOR TO USING THE EDGE OF DOCK, OR IF THE APPLICATION CONDITIONS FOR THE EDGE OF DOCK CHANGE IN ANY RESPECT, CONTACT YOUR AUTHORIZED PENTALIFT REPRESENTATIVE TO CONFIRM THE SPECIFIC DOCK LEVELER'S SUITABILITY FOR THE APPLICATION.



BEFORE DOING ANY INSTALLATION, MAINTENANCE, INSPECTION OR TROUBLE SHOOTING, BARRICADE ALL AREAS FROM TRAFFIC AROUND THE WORK AREA INSIDE (AND OUTSIDE IF APPLICABLE) FOR SAFETY AND POST APPROPRIATE WARNING SIGNS.



Before doing any electrical work, be certain that the power is disconnected with a fused disconnect, properly tagged and locked out. Fused disconnect and lockout device (supplied and installed by others) must meet with all applicable codes and regulations. All electrical work must be performed by a qualified electrician in accordance with all applicable codes and regulations.



Arc flash and shock hazard PPE (personal protection equipment) required. De-energize equipment before working on or inside. Do not open cover without appropriate PPE. Refer to NFPA 70E for PPE requirements. This panel may contain more than one power source. Hazardous voltage will cause severe injury or death.



NEVER GO BENEATH THE EDGE OF DOCK FOR ANY REASON UNLESS THE DECK AND LIP ARE PROPERLY SUPPORTED (SEE Figure 12: Maintenance Stand on page 17) AND THE POWER IS DISCONNECTED, PROPERLY TAGGED AND LOCKED OUT. IT IS THE RESPONSIBILITY OF THE OWNER TO ENSURE THAT NO LOAD OR TRAFFIC IS PLACED ON THE DECK WHILE THE MAINTENANCE STAND IS ENGAGED. THE CONSTRUCTION OF THE MAINTENANCE STAND IS INTENDED TO SUPPORT THE WEIGHT OF THE UNLOADED EDGE OF DOCK ONLY.

DANGER

ALWAYS ASSURE NO ONE IS WITHIN 6 FEET OF THE FRONT (LIP END) OF THE EDGE OF DOCK PRIOR TO ACTIVATION. STAY CLEAR OF THE EDGE OF DOCK WHEN IT IS MOVING.

WARNING

NEVER WALK ON THE DOCK LEVELER LIP UNLESS IT IS FULLY EXTENDED AND SUPPORTED BY THE TRUCK BED.

WARNING

IT IS THE RESPONSIBILITY OF OTHERS TO ENSURE THE PROPER MOUNTING OF ANY WALL MOUNTED EQUIPMENT SUCH AS REMOTE POWER UNITS, CONTROL PANELS AND LIGHT PACKAGES AND TO ENSURE THAT THE MOUNTING SURFACE IS CAPABLE OF FULLY SUPPORTING THE LOADS GENERATED BY THE EQUIPMENT.

1. When not in use, the unit **MUST** be in the fully lowered position.
2. Before loading / unloading the truck, assure the trailer is in position firmly against both of the dock bumpers and **ENGAGE A VEHICLE RESTRAINT OR CHOCK THE TRUCK WHEELS** to eliminate the possibility of the truck rolling or inching forward.
3. Return Edge of Dock to the stored position before allowing truck to depart.
4. Regular inspection and maintenance must be performed to keep the equipment in proper operating condition in accordance with the detailed instructions in this manual.
5. Assure that the equipment is not used by anyone if you believe that any part of it might be in disrepair (e.g. loose wires, leaking hoses, bent structural members, broken welds, etc.). See Warranty Section.
6. The deck surface must be kept clean and free from oil, debris, etc. Keep debris, etc. from underneath the unit.
7. Ensure the working path of the unit is clear of any obstructions.
8. Anyone using or in the vicinity of this equipment must wear protective footwear with steel toes.
9. Never exceed the maximum rated capacity of the Edge of Dock.
10. Never stand between the dock and a truck.
11. Do not operate, use, maintain or install this equipment if you are impaired in any manner.
12. Electrical connections **MUST** be properly routed in order to avoid any potential for severing lines.
13. If you have any questions, contact your immediate supervisor or your authorized Pentalift representative for assistance.

OWNER RESPONSIBILITY

The Owner's Responsibilities include the following:

1. The owner shall recognize the inherent danger of the interface between dock and transport vehicle. The Owner shall, therefore, train and instruct operators in the safe use of dock leveling devices.
2. When a transport vehicle is positioned as closely as practicable to a dock leveling device, there shall be at least 4" (100 mm) of overlap between the front edge of the lip and the edge of the floor or sill of the transport vehicle.
3. Nameplates, cautions, instructions and posted warnings shall not be obscured from the view of operating or maintenance personnel for whom such warnings are intended.
4. Manufacturer's recommended periodic maintenance and inspection procedures in effect at date of shipment shall be followed, and written records of performance of these procedures shall be kept.
5. Dock leveling devices that are structurally damaged or have experienced a sudden loss of support while under load, such as might occur when a transport vehicle is pulled out from under the dock leveling device, shall be removed from service, inspected by **Pentalift Equipment Corporation's** authorized representative and repaired as needed before being placed back in service. The owner shall receive written authorization from **Pentalift Equipment Corporation** through the authorized Pentalift representative that they can continue to use the dock leveler.
6. **Pentalift Equipment Corporation** shall supply replacement nameplates, caution or instruction labels and operating and maintenance manuals upon request of the owner. The owner shall see that all nameplates and caution and instruction markings or labels are in place and legible and that the appropriate operating and maintenance manuals are provided to users.
7. Modifications or alterations of dock leveling devices shall be made only with written permission of **Pentalift Equipment Corporation**. Alteration permission must be signed by both the Pentalift Post Sale Customer Service Manager and the President to be valid.
8. When industrial trucks are driven on and off transport vehicles during the loading and unloading operation, the brakes on the transport vehicle shall be applied and wheel chocks or positive restraints that provide the equivalent protection of wheel chocks engaged.

NOTE: It is recognized that these devices are intended to secure a transport vehicle to a loading dock by mechanical means. However, no standards currently exist for the strength, construction or attachment of the underride guard on a transport vehicle. It is therefore recommended that users of such positive restraint devices review:

- The means of attachment to the transport vehicle
 - The strength of the overall connection
 - The proper coordination of the actuation of devices with any signalling system used
 - The need to use wheel chocks
9. In selecting dock leveling devices, it is important to consider not only present requirements, but also future plans or adverse environments.



Unless specifically agreed to in writing by Pentalift Equipment Corporation at the time the equipment is ordered and prior to the equipment's manufacture, this equipment is sold as a complete package. It is not to be altered, changed or added to in any way or form, in its configuration and function, without the written permission of Pentalift Equipment Corporation.

If requested by a customer, Pentalift Equipment Corporation is not supplying all or some of the power unit and / or control components for the equipment's application. The power unit and controls constitute important safety and functional aspects of the equipment. It is the customer's responsibility to address the operational and safety issues associated with providing the required controls and power units to satisfy the operational and safety requirements of the equipment.

The customer's decision to supply all or some of these components indicates that the customer is taking full responsibility for any and all possible operational, safety and liability issues associated to the product and its configuration. The customer also agrees to absolve Pentalift Equipment Corporation from any and all possible operation, safety and liability issues.

TABLE OF CONTENTS

SAFETY INFORMATION AND WARNINGS.....	I
OWNER RESPONSIBILITY.....	III
TABLE OF CONTENTS.....	1
SAFETY LABELING.....	2
INSTALLATION INSTRUCTIONS.....	3
INSTALLATION.....	5
MOUNTING CHANNEL.....	5
LAG PLATE INSTALLATIONS.....	6
FINAL INSTALLATION.....	8
SELF CONTAINED POWER UNIT.....	8
REMOTE POWER UNIT.....	8
WELDING REFERENCE INFORMATION.....	9
FINAL WELDING.....	9
Bumper Installation Guide lines.....	10
Locating Dock Bumpers during installation:.....	10
Installation methods I.E. Lagging and or welding:.....	10
BREAK-IN AND PERFORMANCE CHECK.....	13
OPERATING INSTRUCTIONS.....	14
END LOADING/ UNLOADING.....	16
HOW TO SUPPORT THE DECK DURING ROUTINE MAINTENANCE OR REPAIRS.....	17
TROUBLE SHOOTING GUIDE.....	18
MAINTENANCE AND LUBRICATION.....	20
REPLACEMENT PARTS.....	22
LIST OF ILLUSTRATIONS.....	23
PENTALIFT EQUIPMENT CORPORATION WARRANTY.....	24

Generic manual for reference only. Contact Pentalift with product serial number to receive owners manual for your specific equipment.

SAFETY LABELING

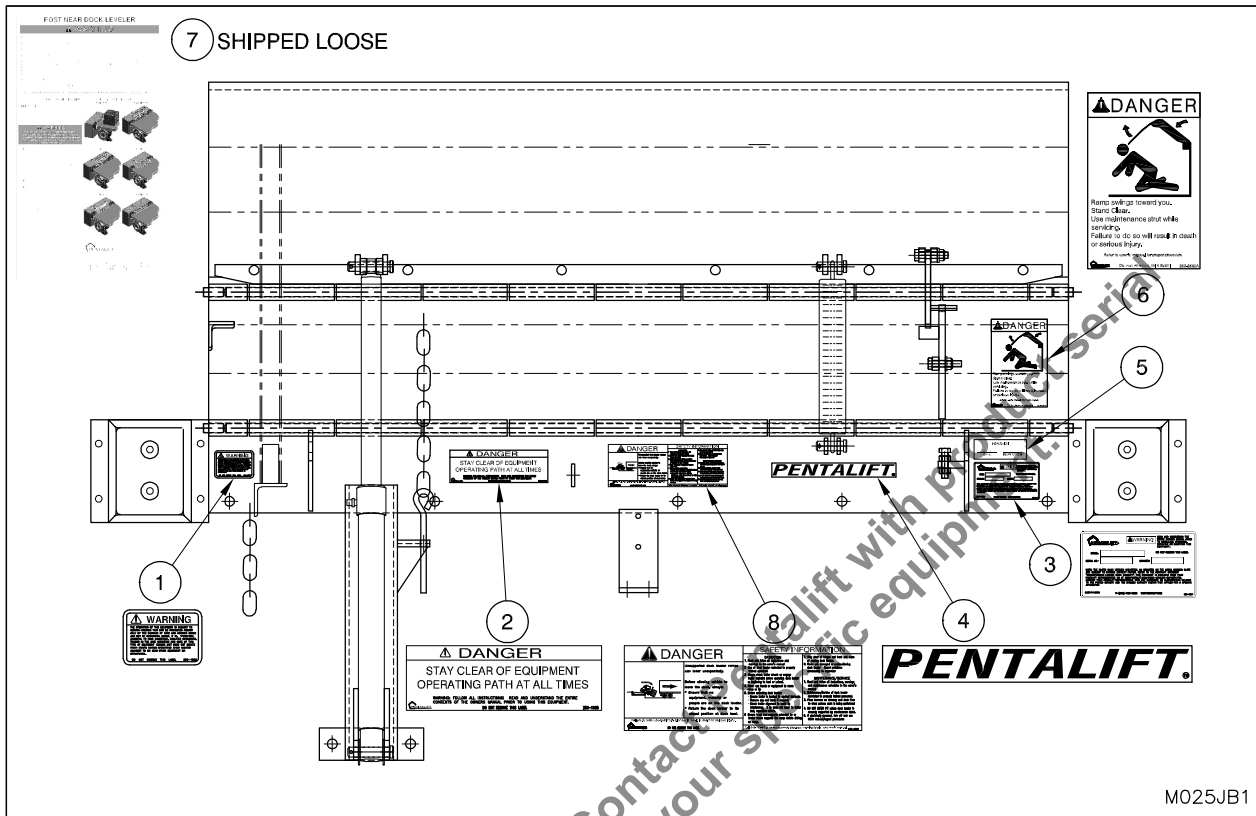

Figure 1: Safety Labels and Decals

Be sure that all labeling is in place and intact when the unit is received. If any of the safety labels or decals are missing or illegible, contact your Pentalift representative for immediate replacement.

NOTE: It is the owner's responsibility to assure that all safety labeling remains legible and in its original position throughout the life of the product. If any of the safety labels or decals are missing or illegible, contact your Pentalift representative for immediate replacement. Inspection shall be done during regular maintenance and lubrication (See MAINTENANCE AND LUBRICATION on page 20).

To re-order labels and decals, use the following part numbers:

ITEM NO.	PART NO.	QTY/UNIT	DESCRIPTION
1	250-1562	1	WARNING
2	250-1085	1	"Stay Clear of Equipment..."
3	250-1817	1	SPECIFICATION PLATE
4	250-1143	1	"PENTALIFT"
5	250-1148	1	"Final Inspection"
6	250-2550	1	"Danger... Stand Clear"
7	250-2532	1	"Operating Instructions"
8	250-2320	1	"Danger Unsupported Dock..."

NOTE: State Model # and Serial # when ordering replacement parts.

INSTALLATION INSTRUCTIONS

⚠ DANGER

Do not install, operate or service this product unless you have read and fully understand the entire contents of this manual. Failure to do so may result in property damage, bodily injury or death.

IMPORTANT PREPARATION PRIOR TO INSTALLATION

Perform installation instructions in the same sequence as they are listed below.

⚠ DANGER

Before doing any installation, maintenance, inspection or trouble shooting, barricade all areas from traffic around the work area inside (and outside if applicable) for safety and post appropriate warning signs.

⚠ DANGER

Before doing any electrical work, be certain that the power is disconnected with a fused disconnect, properly tagged and locked out. Fused disconnect and lockout device (supplied and installed by others) must meet with all applicable codes and regulations. All electrical work must be performed by a qualified electrician in accordance with all applicable codes and regulations.

⚠ DANGER

Arc flash and shock hazard PPE (personal protection equipment) required. De-energize equipment before working on or inside. Do not open cover without appropriate PPE. Refer to NFPA 70E for PPE requirements. This panel may contain more than one power source. Hazardous voltage will cause severe injury or death.

⚠ DANGER

NEVER GO BENEATH THE EDGE OF DOCK FOR ANY REASON UNLESS IT IS PROPERLY SUPPORTED (SEE Figure 12: Maintenance Stand on page 17) AND THE POWER IS DISCONNECTED, PROPERLY TAGGED AND LOCKED OUT. IT IS THE RESPONSIBILITY OF THE OWNER TO ENSURE THAT NO LOAD OR TRAFFIC IS PLACED ON THE DECK WHILE THE MAINTENANCE STAND IS ENGAGED. THE CONSTRUCTION OF THE MAINTENANCE STAND IS INTENDED TO SUPPORT THE WEIGHT OF THE UNLOADED EDGE OF DOCK ONLY.

⚠ DANGER

MAKE SURE LIFTING AND SLINGING DEVICES ARE OF SUFFICIENT CAPACITY, USED IN THE CORRECT MANNER AND ARE IN GOOD WORKING ORDER. ALL LIFTING, POSITIONING AND INSTALLATION, AS WELL AS THE BREAK-IN AND PERFORMANCE CHECK MUST BE DONE BY QUALIFIED PERSONNEL TRAINED AND EXPERIENCED IN NECESSARY SAFETY PROCEDURES.

⚠ CAUTION

BE SURE ALL HYDRAULIC FITTINGS ARE RATED FOR HYDRAULIC SYSTEMS THAT MAY PEAK OUT AT 4000PSI. HARDWARE STORE ITEMS CAN BURST AT 150PSI. ONLY BUY REPLACEMENT PARTS FROM PENTALIFT.

⚠ WARNING

It is the responsibility of others to ensure the proper mounting of any wall mounted equipment such as remote power units, control panels and light packages and to ensure that the mounting surface is capable of fully supporting the loads generated by the equipment.

Note On Capacity: The dock leveler capacity indicated on the serial plate must be divided with a factor to accommodate dynamic loading factors. For more information see Pentalift document - Dock Leveler Capacity – Understanding Loading Dock Capacity at <http://www.pentalift.com/dock-leveler-capacity.htm>

1. Remove any packing material and inspect for visible damage. All claims must be made against the carrier immediately.
2. Clean area of all debris. Fluid spills may later be misinterpreted as new fluid leaks. Check all hydraulic fittings for leaks.
3. Assure concrete, curb angle or channel has sufficient strength to meet the draw pull forces which will be applied. (See Figure 2: Load Specification on page 4)
4. Mark centerline of door opening and centerline on dock back plate.

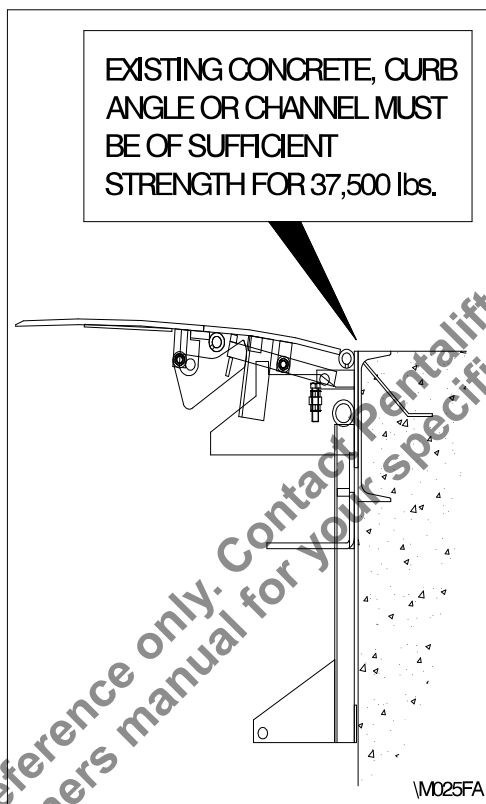

Figure 2: Load Specification

INSTALLATION

MOUNTING CHANNEL

(See Figure 3, page 5)

1. Position back plate of dock flush with top of curb channel or curb angle, matching centerlines of dock and door opening. Care must be taken to assure the back plate of the dock remains straight. Shim any gaps caused by uneven curb channel to maintain a straight back plate.
2. Tack weld back plate to curb channel /angle starting at the centerline and working outward to hold the unit in place.
3. Position bumper boxes as shown in Figure 3 and tack weld to curb channel/angle.
4. Using back plate and bumper boxes as templates, drill 5/8" dia. x 5" deep lag holes into dock face.

NOTE: If the curb channel is large enough to be seen through the holes in the back plate, plug weld the back frame to the channel using the holes provided rather than drilling and lagging as described in items 4 and 5.

5. Lag unit to dock face using 5/8" dia. x 4 1/2" long wedge anchors with a minimum shear value of 12, 900 lb (5,850 kg), and tension value of 10,200 lb (4,630 kg). Torque to manufacturers' specifications.
6. Go to FINAL INSTALLATION on page 8.

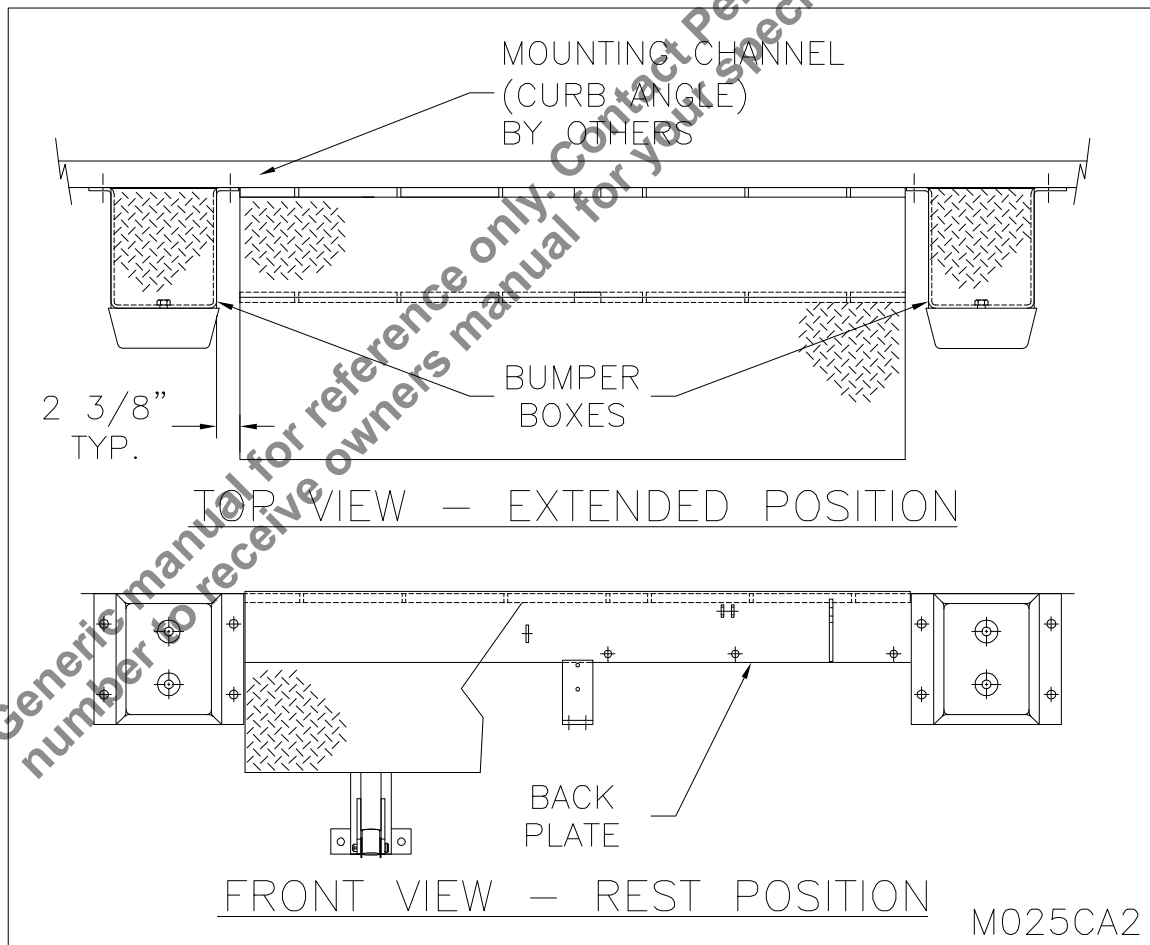

Figure 3: Mounting Channel

LAG PLATE INSTALLATIONS

(See Figure 4, page 7)

If the dock face does not have a curb channel or curb angle, follow these instructions using the optional lag plate which can be purchased from your authorized Pentalift distributor.

1. Position Back Plate of dock 1/4" above floor, matching centerline of door opening and center line of back plate.
2. Using the back plate as a template, drill 5/8" dia. x 5" deep holes into dock face.
3. Using 5/8" x 4 1/2" long wedge anchors, securely fasten back frame. Wedge anchors must have a minimum shear value of 12, 900 lbs (5,850 kg), and tension value of 10,200 lbs (4,630 kg). Torque to manufacturers' specifications.
4. Position bumper boxes as shown in Figure 3: Mounting Channel on page 5, and 1/4" above the floor.
5. Using bumper boxes as a template drill 5/8" dia. x 5" deep holes into dock face.
6. Using 5/8" x 4 1/2" long wedge anchors, securely fasten bumper boxes.
7. Mark centerline on lag plate.
8. Position lag plates flush with top of back plate, matching centerline of lag plate and centerline of back plate.
9. Weld the lag plates together and grind the seam flush.
10. Tack weld lag plates flush with top of back plate, matching centerline of lag plate and centerline of back plate.
11. Using the lag plate as a template, drill 7/8" dia. x 2 3/4" deep holes into the floor.
12. Remove the lag plate and clean floor.
13. Put 5/8" internal threaded by 7/8" outside diameter, drop-in anchors in the holes. Using a punch, hammer the anchor insert to expand anchor in the hole.
14. Reposition the lag plate. Thread 5/8" x 2 1/2" long, button head fasteners into the anchors. Torque to manufacturers' specifications.
15. Go to FINAL INSTALLATION on page 8.

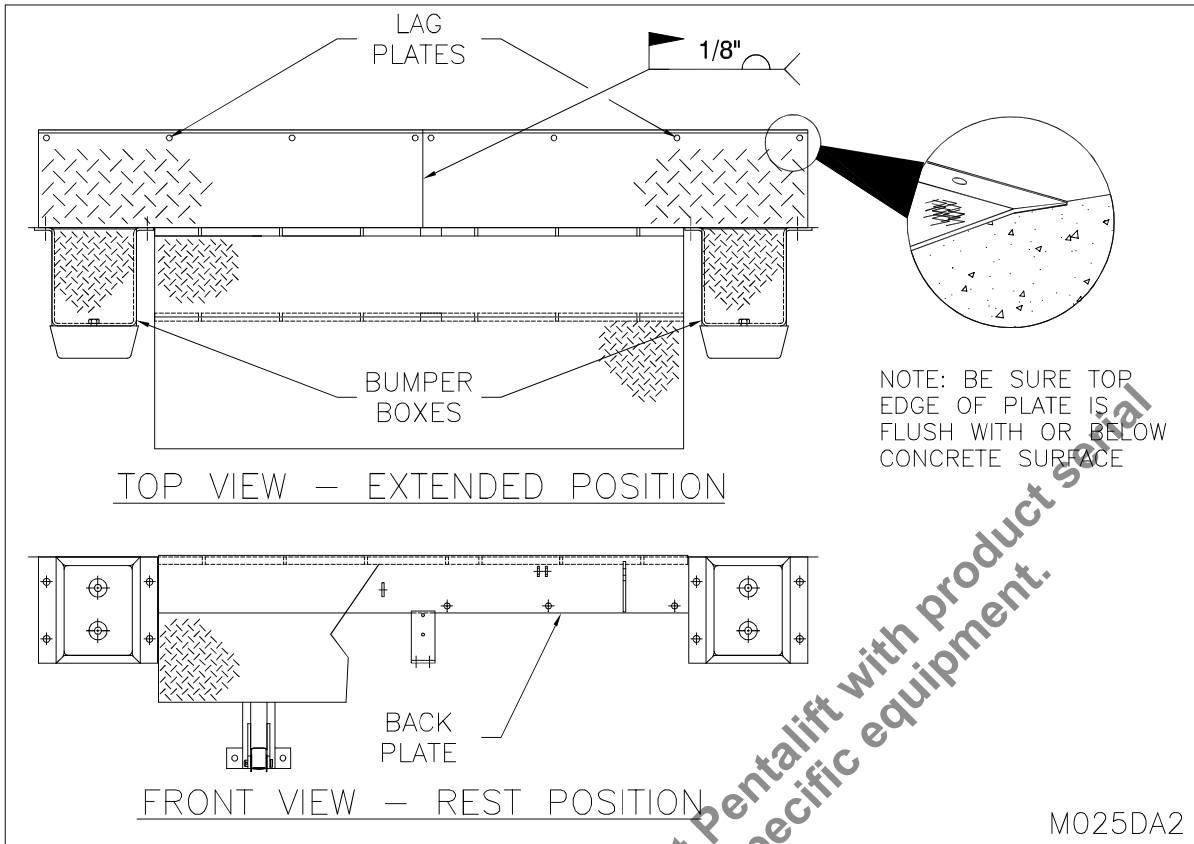

Figure 4.1: Lag Plate - 96" LONG

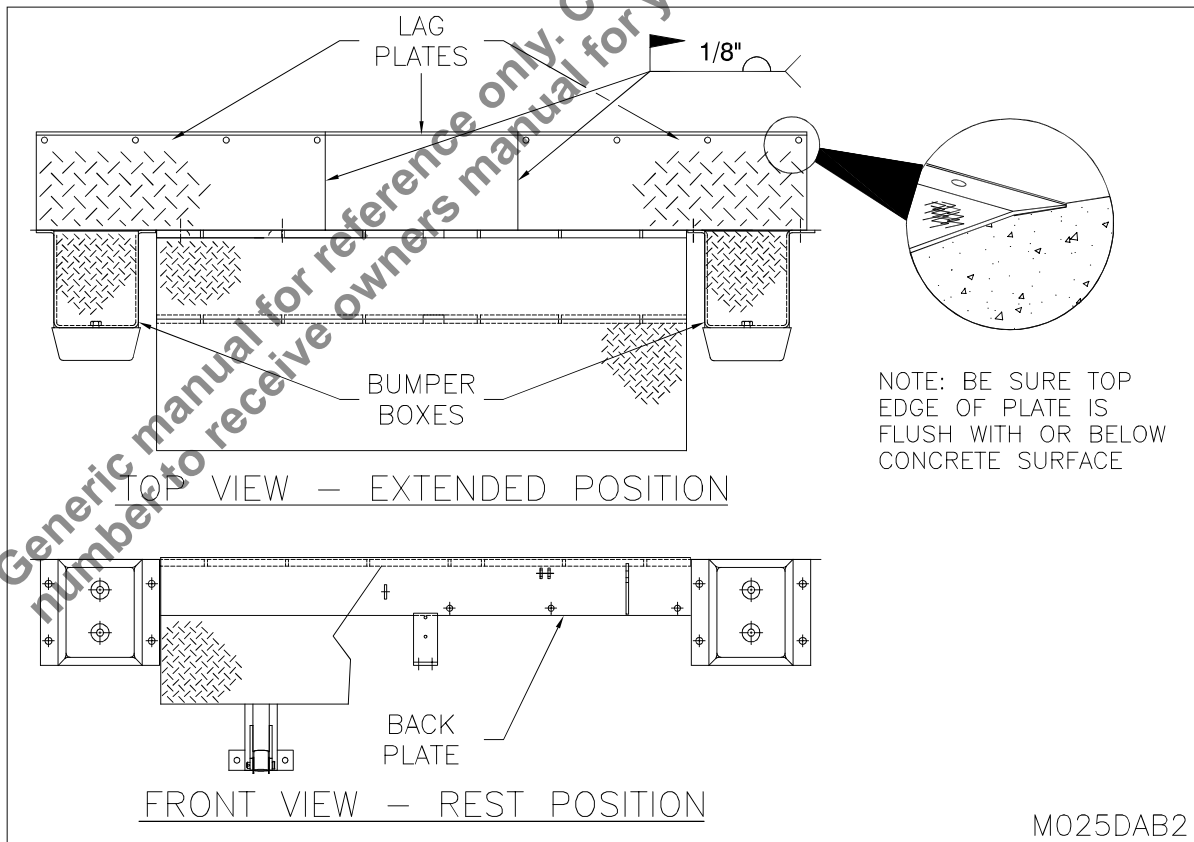

Figure 4.2: Lag Plate - 120" LONG

FINAL INSTALLATION



Before doing any installation, maintenance, inspection or trouble shooting, barricade all areas from traffic around the work area inside (and outside if applicable) for safety and post appropriate warning signs.



Before doing any electrical work, be certain that the power is disconnected with a fused disconnect, properly tagged and locked out. Fused disconnect and lockout device (supplied and installed by others) must meet with all applicable codes and regulations. All electrical work must be performed by a qualified electrician in accordance with all applicable codes and regulations.



Arc flash and shock hazard PPE (personal protection equipment) required. De-energize equipment before working on or inside. Do not open cover without appropriate PPE. Refer to NFPA 70E for PPE requirements. This panel may contain more than one power source. Hazardous voltage will cause severe injury or death.



- WIRING MUST BE DONE BY A QUALIFIED ELECTRICIAN.
- ALWAYS USE APPROPRIATE LOCK-OUT PROCEDURES DURING ANY ELECTRICAL INSTALLATIONS.
- ASSURE SUPPLY VOLTAGE IS CORRECT.
- ALWAYS OBSERVE ALL APPLICABLE ELECTRICAL CODES AND REGULATIONS.

SELF CONTAINED POWER UNIT

1. Mount push button in appropriate location.
2. Feed Electrical line through conduit from push button to power unit and connect as per wiring diagram located in control panel. (**Note:** All electrical connections **MUST** be made by qualified personnel. Refer to DANGER warnings noted above)
3. Connect main power supply line to push button. Ensure that the thermal overload relay is set to match the full load current as shown on the motor name plate. Consult all applicable electrical codes.
4. Cycle unit five times to ensure proper operation and to remove air from hydraulic system.
5. Go to FINAL WELDING on page 9.

REMOTE POWER UNIT

1. Mount push button and power unit in appropriate location.
2. Feed hydraulic hose through 3" dia. conduit (with a minimum 14" bend radius) to power unit. (**Note:** Hydraulic hose is located under Edge of Dock. Hoses must stay connected to cylinder.)
3. Connect the hydraulic line to the power unit and the #4 JIC fitting on the lift cylinder.
4. Run electrical line from push button to motor of power unit and connect as per wiring diagram located in control panel. (**Note:** All electrical connections **MUST** be made by qualified personnel. Refer to DANGER warnings noted above.)
5. Connect main power supply line to push button. Ensure that the thermal overload relay is set to match the full load current as shown on the motor name plate. Consult all applicable electrical codes.
6. Cycle unit five times to ensure proper operation and to remove air from the hydraulic systems.
7. Go to FINAL WELDING on page 9.

FINAL WELDING

1. Stitch weld full length back plate, using 5 - 6" welds. Weld 2" weld around upper corners of back plate and tack weld all anchor heads in place (See Figure 5: Welding at Final Installation on page 9 and WELDING REFERENCE INFORMATION on page 9).
2. Lubricate and test in accordance with the Break-in and Performance Check procedures on page 13.

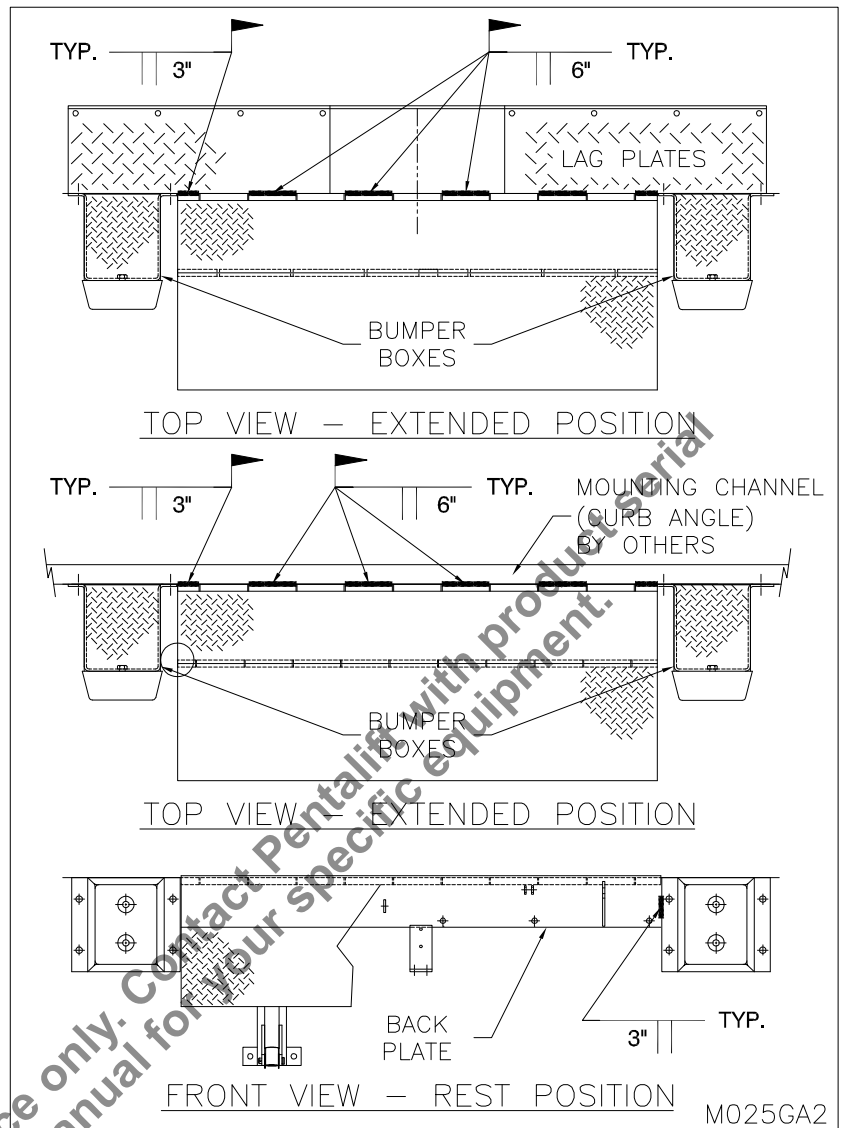

WELDING REFERENCE INFORMATION

- Observe and obey all welding safety requirements per AWS D1.1-92. (W117.2-74 in Canada.)
- Welding electrodes are to be clean and free from moisture.
- Material to be welded must be clean and free of oils, excessive millscale/rust etc.
- All craters are to be filled to a minimum of 85% of the cross sectional area of the weld.
- All under cutting is to be removed by either welding, grinding or a combination of both.
- Maximum reinforcement on butt welds is 1/8".
- Use highest current possible per chart below to obtain satisfactory weld.

Electrode	E7018	
Diameter	1/8"	5/32"
Amperage	130-150	140-180



FAILURE TO PROPERLY INSTALL THE EDGE OF DOCK MAY RESULT IN PROPERTY DAMAGE, BODILY INJURY OR DEATH AND WILL VOID ALL WARRANTIES.

Bumper Installation Guide lines

LOCATING DOCK BUMPERS DURING INSTALLATION:

1. For the majority of pit type dock leveler installations the dock bumpers are vertically positioned with the top edge of the bumper flush with the top of the loading dock wall face adjacent to top of the dock leveler pit vertical wall. (of the top of where the dock face meets the dock floor.)
2. For the majority of pit type dock leveler installations the dock bumpers are horizontally positioned with the inside edge of the bumper as close to the vertical edge of the dock leveler pit wall as reasonably possible.
3. Note: The word majority is utilized in the above two statements because there maybe exceptions to these rules. The purpose of the dock bumper is to create a designed impact area for approaching truck / trailer traffic. If the above location guidelines would result in locating the bumper such that it will not be properly impacted by the truck and trailers intended to be serviced at the facility, adjustments in positioning and the actual bumper arrangements may be required. Remember that trucks and trailers come in different physical configurations and sizing. The dock bumpers should be positioned to accommodate all the variations that will be serviced. Bumper risers are optionally added to accommodate lower dock heights and / or higher trucks. Bumper extensions or projected pits are optionally added to accommodate applications where the normal bumper projection is insufficient such as declined dock approaches. Contact your Pentalift representative for more information or guidelines to suit a specific application.

Installation methods I.E. Lagging and or welding:

1. Dock bumpers are generally attached in two ways; 1) utilization of concrete lag bolts or 2) welding in position. The use of these two methods depends on the type and configuration of the bumpers selected and the actual installation location.
2. It is quite common for the installation to be a combination of concrete lag bolts and welding.
3. When concrete lag bolts are utilized the dock bumper is usually provided with holes or has a bracket(s) on it with holes to accommodate the lagging. The dock bumper can be moved into the correct final position and used as a template to mark the required hole location for the lag bolts. Lag bolts that accommodate a minimum tensile value of 8710kN and shear value of 12015kN are to be utilized. Confirm the concrete arrangement and composition as well the that bumper hole location provides sufficient concrete material and strength to accommodate the selected lag bolts. Install the lag bolts according to the lag bolt manufacturer's instructions.
4. For welding attachment of bumpers, both the dock bumper and the loading dock area must be designed to accommodate. Typically the bumper will be provided with a flat bar (in place of the bracket with holes). That flat bar will line up with a steel surface that has been located and is suitably anchored into the dock face. Weld the dock bumper flat bar with ¼" welds and 2" stitches a maximum of 4" apart. More weld is better than not enough. Clean and paint the welds after application and cooling.

DB13 Bumper Typical Installation

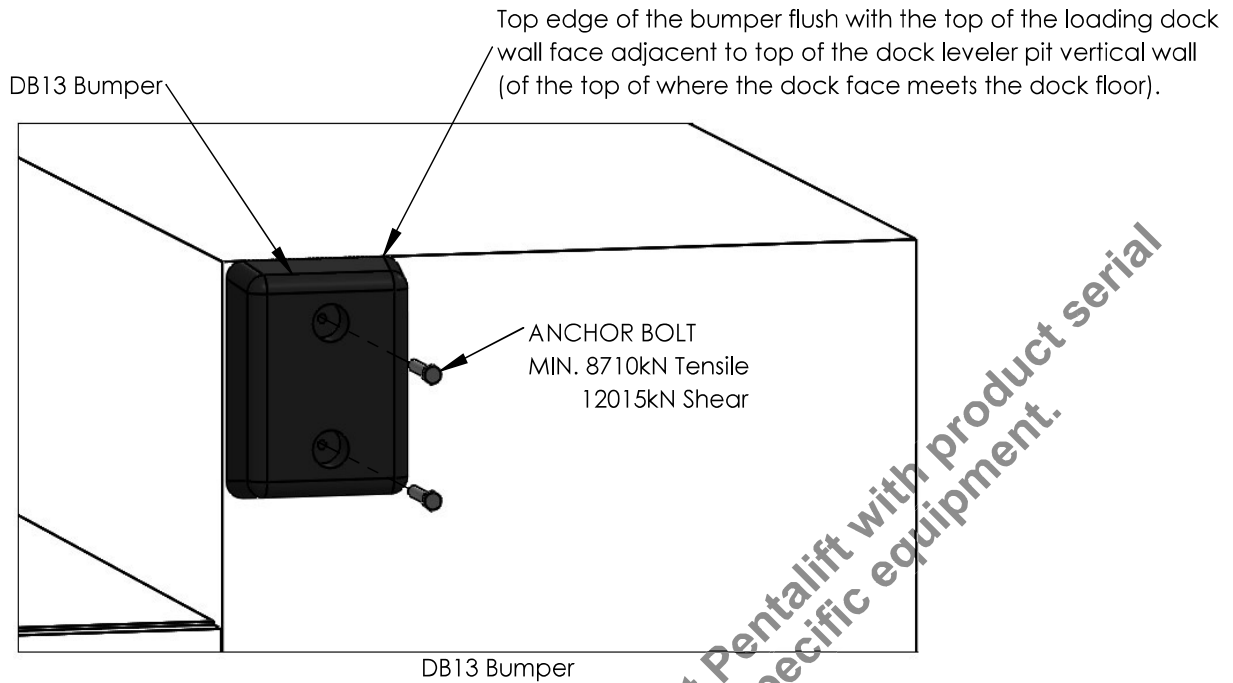

M056AB

Figure 6: DB13 Installation

Bumper Angle Flat-bar Typical Installation

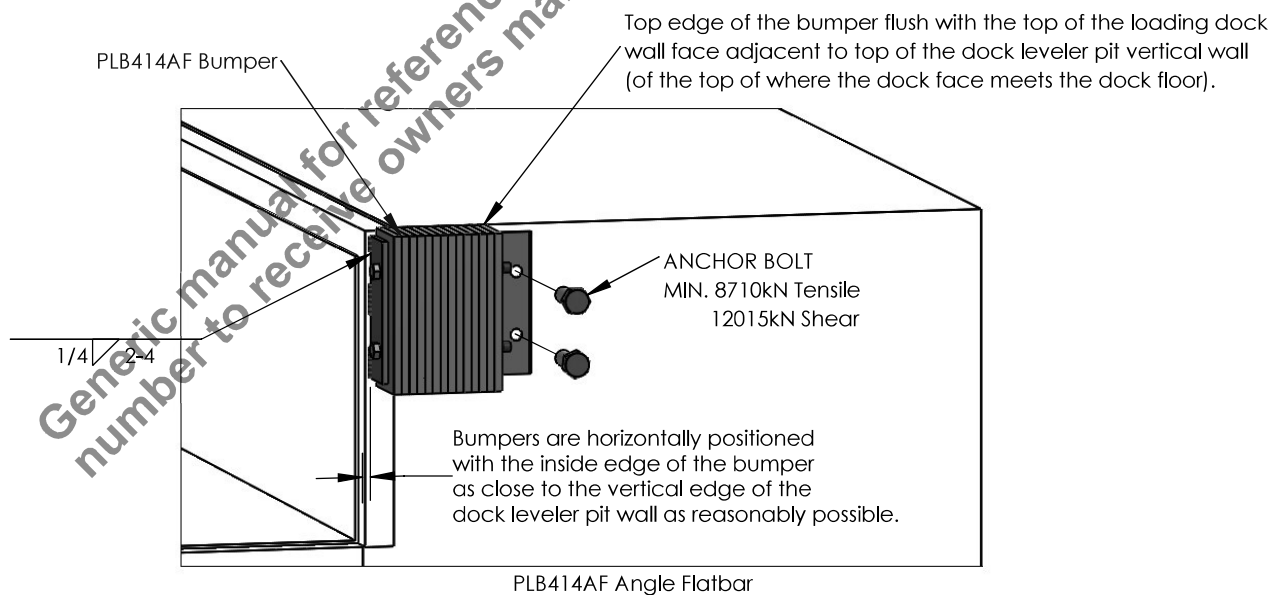

M056AC

Figure 7: PLB414AF Installation

Bumper Angle Angle Typical Installation

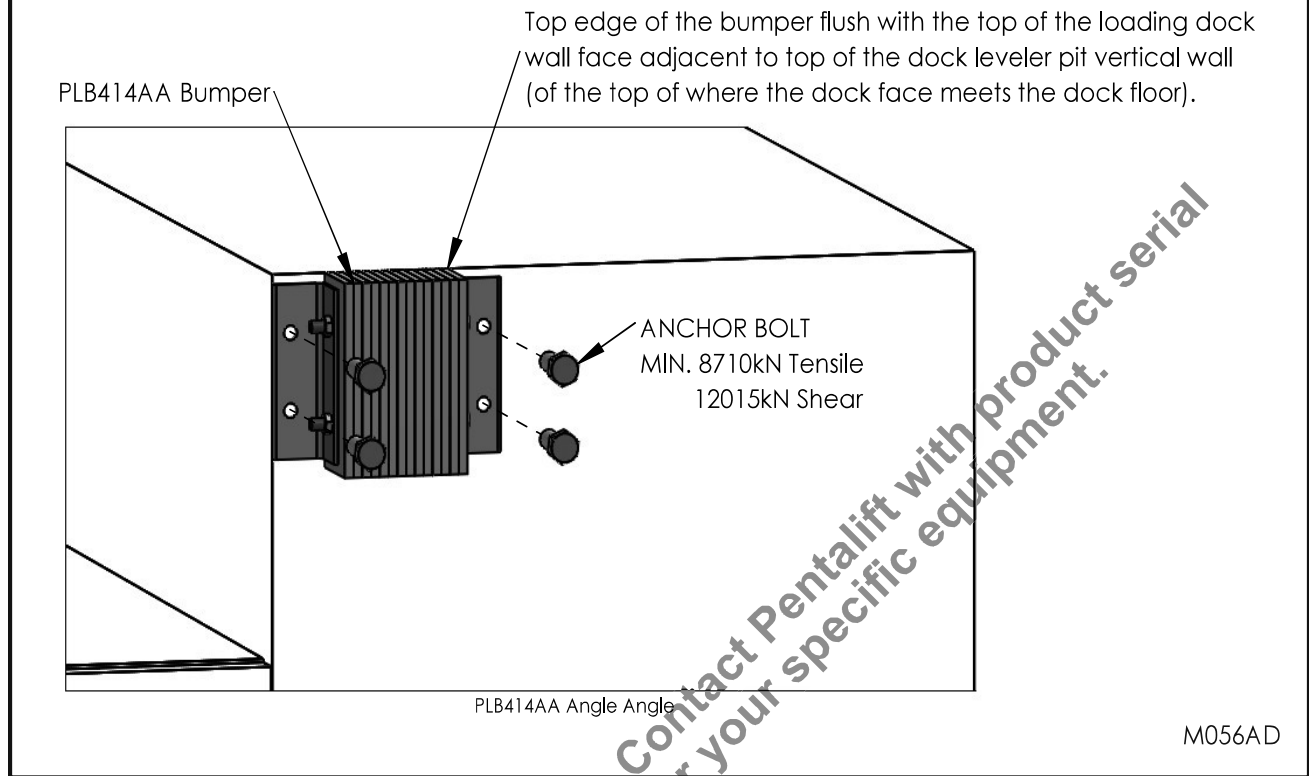

Figure 8: PLB414 Installation

Generic manual for reference only. Contact Pentalift with product serial number to receive owners manual for your specific equipment.

BREAK-IN AND PERFORMANCE CHECK

DANGER

BEFORE DOING ANY INSTALLATION, MAINTENANCE INSPECTION OR TROUBLE SHOOTING, BARRICADE ALL AREAS FROM TRAFFIC AROUND THE WORK AREA INSIDE (AND OUTSIDE IF APPLICABLE) FOR SAFETY AND POST APPROPRIATE WARNING SIGNS.

NOTE: IN SOME CASES THERE IS A CONSIDERABLE AMOUNT OF TIME BETWEEN THE SHIPMENT DATE AND USE OF YOUR HYDRAULIC EDGE OF DOCK. THIS INITIAL BREAK-IN AND PERFORMANCE CHECK SHOULD BE PERFORMED BEFORE YOU BEGIN REGULAR USE OF YOUR DOCK LEVELER TO ENSURE THAT IT IS OPERATING PROPERLY.

NOTE: Read the SAFETY INFORMATION AND WARNINGS before operating the dock leveler. (See page iii)

1. Ensure that any specified interlocks (i.e. overhead doors, restraints) are fully functional.

DANGER

ALWAYS ASSURE NO ONE IS WITHIN 6 FEET OF THE FRONT (LIP END) OF THE EDGE OF DOCK PRIOR TO ACTIVATION. STAY CLEAR OF THE EDGE OF DOCK WHEN IT IS MOVING.

2. Cycle Edge of Dock through all its functions a minimum of ten times. This will remove any air trapped in the hydraulic system.
3. Release the lip from its locked (extended) position. Stand facing the lip end of the edge of dock and firmly grasp the lip with both hands. Lift the lip upwards until the mechanical lip lock releases. Gently lower the lip until it hangs vertically.
4. Inspect hydraulic system for leaks.
5. Lubricate all pivot points. (See MAINTENANCE AND LUBRICATION on page 20)

6. **NOTICE** As the performance test is being conducted, watch closely for any signs that the dock leveler might not be operating properly. If you are in doubt, refer to OPERATING INSTRUCTIONS on page 149 and TROUBLE SHOOTING GUIDE on page 18 or contact your Pentalift representative.

OPERATING INSTRUCTIONS

⚠ DANGER

USE BY UNTRAINED PEOPLE CAN RESULT IN PROPERTY DAMAGE, BODILY INJURY OR DEATH. READ, KNOW, AND OBEY ALL OPERATING INSTRUCTIONS AND SAFETY INFORMATION. FOLLOW ALL OSHA REGULATIONS REGARDING THE USE OF THIS EQUIPMENT. DO NOT USE THE HYDRAULIC EDGE OF DOCK IF ANY PART OF IT LOOKS BROKEN OR IF IT DOES NOT SEEM TO OPERATE PROPERLY. IF REPAIRS ARE NEEDED, CONTACT YOUR NEAREST PENTALIFT REPRESENTATIVE.

Note On Capacity: The dock leveler capacity indicated on the serial plate must be divided with a factor to accommodate dynamic loading factors. For more information see Pentalift document - Dock Leveler Capacity – Understanding Loading Dock Capacity at <http://www.pentalift.com/dock-leveler-capacity.htm>

NOTE: It is common for this product to be supplied in combination with other Pentalift Products. When the product supplied with other Pentalift products it is quite common for a combination control panel to be provided. The combination control panel will be a single control panel from which more than one product will be controlled and operated. If your installation incorporates the use of such a common control panel then read and follow all the instructions on the panel. If the instructions on the control panel conflict with instructions in this manual then follow the instructions on the control panel.

NOTE: Read the **SAFETY INFORMATION AND WARNINGS** before operating the dock leveler. (See page iii)

NOTE: Always be certain that the truck/trailer is parked tight against the face of both dock bumpers and that the truck is locked in place by a vehicle restraint and/or that the truck wheels are chocked before loading or unloading. All 'air ride' trailers must release the air from the suspension mechanism prior to activating the dock leveler for use.

1. Load or unload end loads (See END LOADING/ UNLOADING on page 16) with the deck and lip in the stored position (See Figure 6a)

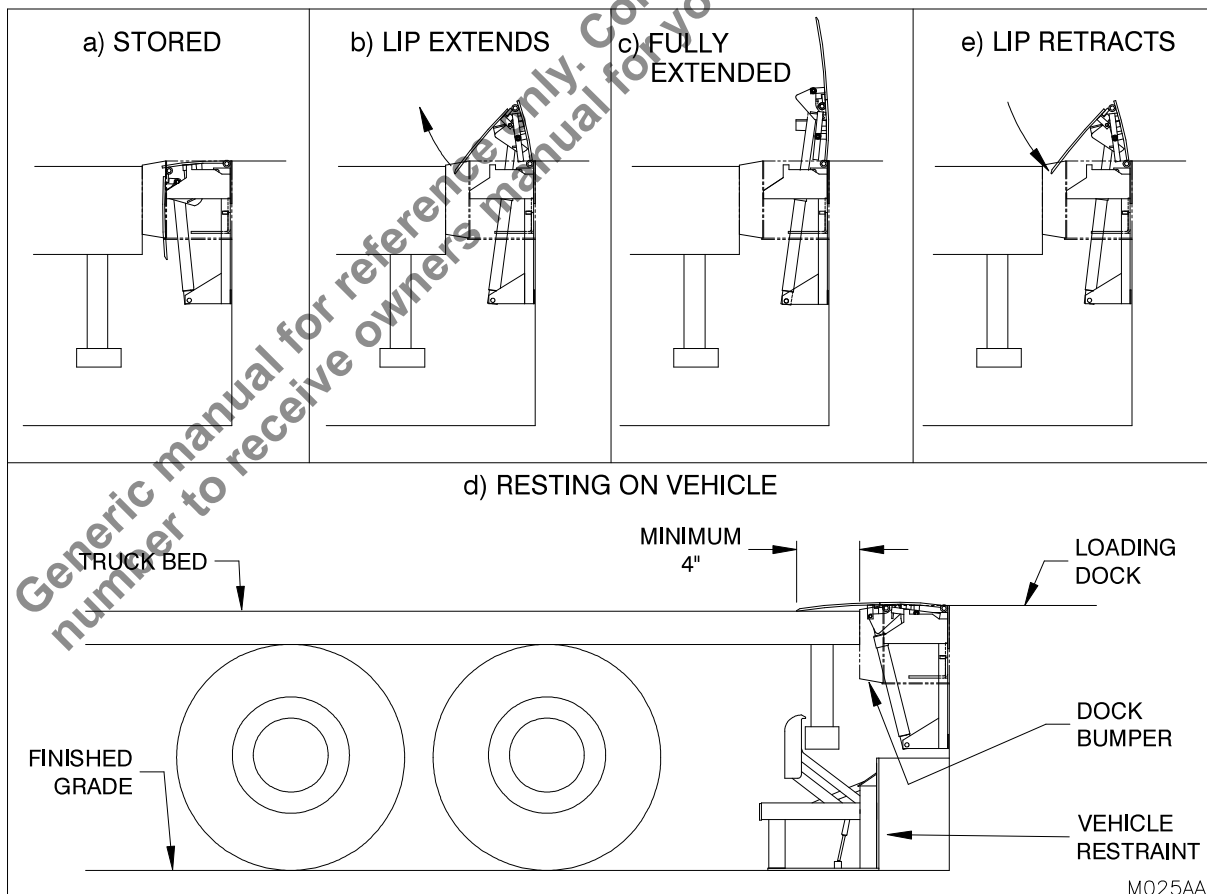

2. Depress and hold the RAISE button to raise the deck. The lip will automatically extend during the course of the cycle (See Figure 6b). Hold the button until the deck and lip have reached full extension (See Figure 6c).
3. Release the RAISE button to allow the deck to lower until firm contact is made with the truck bed. NOTE: The lip must extend a minimum of 4" onto the truck bed (See Figure 6d). In the case of a truck bed.
4. Proceed to load/unload the vehicle. When completed, return the dock to its stored position by depressing the RAISE button. Once the lip clears the end of the truck bed (See Figure 6e) release the RAISE button and the unit will return to the stored position.
5. In the case of a truck leaving while the edge of dock is in the resting on vehicle position (See Figure 7a), the edge of dock has a mechanism in place to automatically position itself to the stored position (See Figure 7b). This prevents damage from occurring if a vehicle were to back up into edge of dock while it is in the extended position.

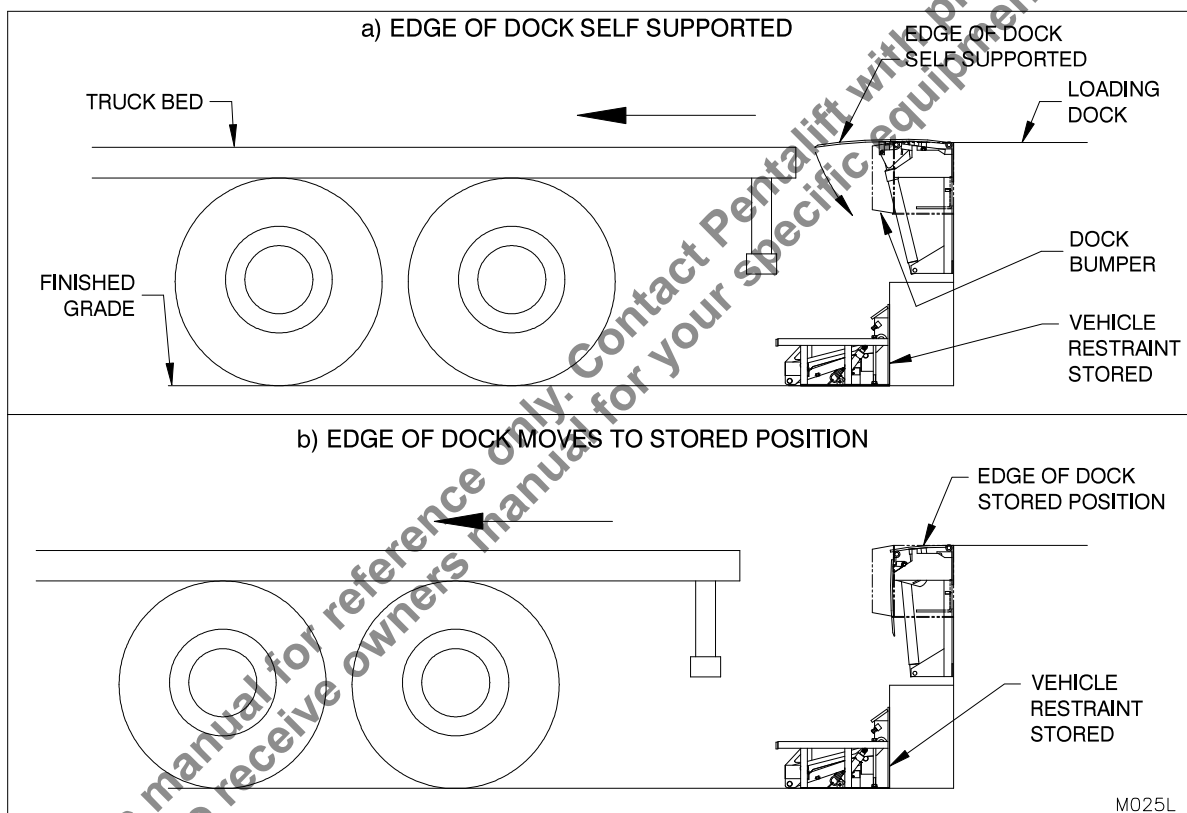

Figure 10: Edge of Dock Unsupported

END LOADING/ UNLOADING



WHEN THE CARGO AT THE REAR OF THE TRUCK DOES NOT ALLOW THE LIP TO FULLY EXTEND AND REST FIRMLY ON THE TRUCK BED AS OUTLINED UNDER THE OPERATING INSTRUCTIONS (SEE page 14), THEN THE END LOADING/UNLOADING PROCEDURES MUST BE USED AS OUTLINED UNDER THE OPERATING INSTRUCTIONS.

DURING END LOADING/UNLOADING THERE WILL BE A GAP PRESENT BETWEEN THE DOCK LEVELER AND THE TRUCK BED. ENSURE THAT THE FRONT WHEELS OF THE FORK TRUCK NEVER FALL INTO THE GAP BETWEEN THE STORED DOCK LEVELER AND THE TRUCK.

IMMEDIATELY AFTER THE END LOADS ARE REMOVED, THE EDGE OF DOCK IS TO BE USED WITH THE LIP EXTENDED AS INDICATED UNDER OPERATING INSTRUCTIONS.

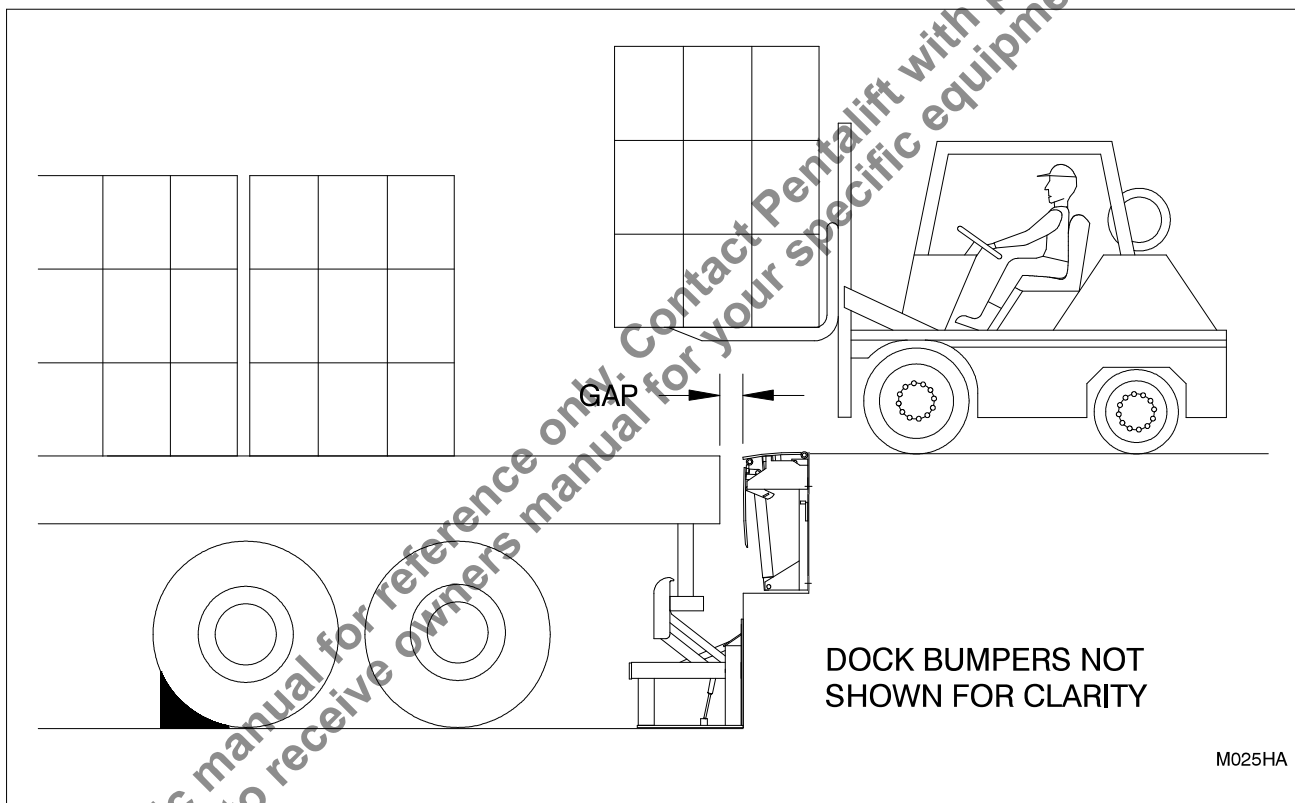

Figure 11: End Loading/ Unloading

HOW TO SUPPORT THE DECK DURING ROUTINE MAINTENANCE OR REPAIRS

⚠ DANGER

BEFORE DOING ANY INSTALLATION, MAINTENANCE, INSPECTION OR TROUBLE SHOOTING, BARRICADE ALL AREAS FROM TRAFFIC AROUND THE WORK AREA INSIDE (AND OUTSIDE IF APPLICABLE) FOR SAFETY AND POST APPROPRIATE WARNING SIGNS.

⚠ DANGER

NEVER GO BENEATH THE EDGE OF DOCK FOR ANY REASON UNLESS IT IS PROPERLY SUPPORTED (SEE Figure 12: Maintenance Stand on page 17) AND THE POWER IS DISCONNECTED, PROPERLY TAGGED AND LOCKED OUT. IT IS THE RESPONSIBILITY OF THE OWNER TO ENSURE THAT NO LOAD OR TRAFFIC IS PLACED ON THE DECK WHILE THE MAINTENANCE STAND IS ENGAGED. THE CONSTRUCTION OF THE MAINTENANCE STAND IS INTENDED TO SUPPORT THE WEIGHT OF THE UNLOADED EDGE OF DOCK ONLY.

⚠ DANGER

Arc flash and shock hazard PPE (personal protection equipment) required. De-energize equipment before working on or inside. Do not open cover without appropriate PPE. Refer to NFPA 70E for PPE requirements. This panel may contain more than one power source. Hazardous voltage will cause severe injury or death.

⚠ DANGER

THE BLOCKING PROCEDURES DESCRIBED BELOW ARE SUITABLE ONLY FOR THE INSPECTION, TROUBLE SHOOTING AND MAINTENANCE PROCEDURES DESCRIBED IN THIS MANUAL. THEY MAY NOT BE SAFE FOR OTHER INSPECTION, MAINTENANCE AND REPAIR PROCEDURES THAT MAY BE REQUIRED. CONTACT YOUR AUTHORIZED PENTALIFT REPRESENTATIVE FOR DIRECTION PRIOR TO UNDERTAKING ANY ACTIONS OTHER THAN THOSE DESCRIBED IN THIS MANUAL.

1. It is necessary to have two people to perform this function. One person must **PRESS AND HOLD** the raise button until STEP #2 is completed.
2. Position the maintenance stand tube over the maintenance stand locating post.
3. Release the raise button. The lip will rest on the maintenance stand.
4. To remove the maintenance stand, one person must **PRESS AND HOLD** the raise button. The other person will place the maintenance stand in the stored position and immediately move clear of the equipment operating path. Once all personnel are clear of the equipment operating path, the raise button is released, allowing the dock to lower.
5. Release the lip from its locked (extended) position. Stand facing the lip end of the edge of dock and firmly grasp the lip with both hands. Lift the lip upwards until the mechanical lip lock releases. Gently lower the lip until it hangs vertically.

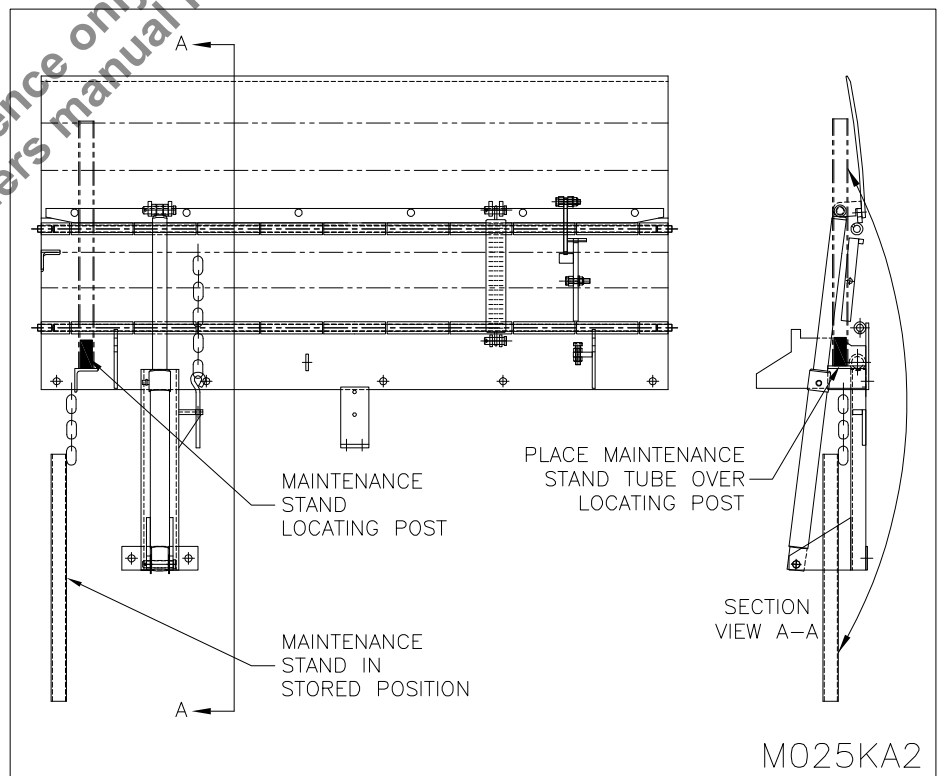

Figure 12: Maintenance Stand

TROUBLE SHOOTING GUIDE

NOTE: This equipment has been fully tested and confirmed to be operational at the factory. Historically, the majority of operating problems are caused by unnecessary tampering by unqualified personnel. To conform to the terms of the Warranty, contact your authorized Pentalift representative if you are having any difficulty with the edge of dock during the warranty period. Do not risk voiding the warranty by tampering with the equipment.

⚠ DANGER

BEFORE DOING ANY INSTALLATION, MAINTENANCE, INSPECTION OR TROUBLE SHOOTING, BARRICADE ALL AREAS FROM TRAFFIC AROUND THE WORK AREA INSIDE (AND OUTSIDE IF APPLICABLE) FOR SAFETY AND POST APPROPRIATE WARNING SIGNS.

⚠ DANGER

Before doing any electrical work, be certain that the power is disconnected with a fused disconnect, properly tagged and locked out. Fused disconnect and lockout device (supplied and installed by others) must meet with all applicable codes and regulations. All electrical work must be performed by a qualified electrician in accordance with all applicable codes and regulations.

⚠ DANGER

Arc flash and shock hazard PPE (personal protection equipment) required. De-energize equipment before working on or inside. Do not open cover without appropriate PPE. Refer to NFPA 70E for PPE requirements. This panel may contain more than one power source. Hazardous voltage will cause severe injury or death.

⚠ DANGER

NEVER GO BENEATH THE EDGE OF DOCK FOR ANY REASON UNLESS IT IS PROPERLY SUPPORTED (SEE Figure 12: Maintenance Stand on page 17) AND THE POWER IS DISCONNECTED, PROPERLY TAGGED AND LOCKED OUT. IT IS THE RESPONSIBILITY OF THE OWNER TO ENSURE THAT NO LOAD OR TRAFFIC IS PLACED ON THE DECK WHILE THE MAINTENANCE STAND IS ENGAGED. THE CONSTRUCTION OF THE MAINTENANCE STAND IS INTENDED TO SUPPORT THE WEIGHT OF THE UNLOADED EDGE OF DOCK ONLY.

NOTICE

See page 20 for recommended hydraulic oil.

1. Motor does not run when push button is engaged:

- Check circuit breaker or fuses at the main power supply and the disconnect.
- Check for loose wires in the control panel.
- Check to ensure all connections made match the wiring diagram (supplied with control panel).
- If the problem cannot be solved, consult your authorized Pentalift representative.

2. Motor runs but deck does not rise:

- Check for debris or obstruction that may interfere with the operation of any moving part.
- If the problem cannot be solved, consult your authorized Pentalift representative.

3. Deck rises but will not lower:

- Check for bowing and binding in hinges due to improper installation.
- Check for debris or obstruction that may interfere with the operation of any moving part.
- Return spring may be disconnected or broken.
- If the problem cannot be solved, consult your authorized Pentalift representative.

4. Main breaker or overload relay is tripping out:

- Check for a short circuit in the wiring.
- Check all wire connections and assure the unit is wired according to the wire diagram supplied with the control panel.
- If the problem cannot be solved, consult your authorized Pentalift representative.

5. Edge of Dock will rise but has a bouncing movement:

- a) Check the hydraulic fluid level. (See page 20.)
- b) Check the deck assembly for debris or obstruction.
- c) Ensure that the cylinder brackets are properly secured.
- d) If the problem cannot be solved, consult your authorized Pentalift representative.

6. The lip does not retract:

- a) Check if lip lock has disengaged.
- b) Inspect the lip spools for debris or obstructions and ensure the lip is moving freely. Lubricate if required.
- c) If the problem cannot be solved, consult your authorized Pentalift representative.

If damaged or worn parts are detected upon inspection, replacement must be undertaken **immediately**. **The edge of dock must not be used until replacement is completed.** Parts are readily available from your Pentalift representative.

Generic manual for reference only. Contact Pentalift with product serial number to receive owners manual for your specific equipment.

MAINTENANCE AND LUBRICATION

⚠ DANGER

BEFORE DOING ANY INSTALLATION, MAINTENANCE, INSPECTION OR TROUBLE SHOOTING, BARRICADE THE INSIDE (AND OUTSIDE IF APPLICABLE) WORK AREAS FOR SAFETY AND POST APPROPRIATE WARNING SIGNS. NEVER GO BENEATH THE EDGE OF DOCK FOR ANY REASON UNLESS THE DECK AND LIP ARE PROPERLY SUPPORTED (SEE Figure 12: Maintenance Stand on page 17) AND THE POWER IS DISCONNECTED, PROPERLY TAGGED AND LOCKED OUT. IT IS THE RESPONSIBILITY OF THE OWNER TO ENSURE THAT NO LOAD OR TRAFFIC IS PLACED ON THE DECK WHILE THE MAINTENANCE STAND IS ENGAGED. THE CONSTRUCTION OF THE MAINTENANCE STAND IS INTENDED TO SUPPORT THE WEIGHT OF THE UNLOADED DOCK LEVELER ONLY.

⚠ DANGER

Arc flash and shock hazard PPE (personal protection equipment) required. De-energize equipment before working on or inside. Do not open cover without appropriate PPE. Refer to NFPA 70E for PPE requirements. This panel may contain more than one power source. Hazardous voltage will cause severe injury or death.

NOTE: Read the SAFETY INFORMATION AND WARNINGS before servicing the edge of dock. (See page i.)

NOTE: It is the owner's responsibility to assure that all labeling remains legible and in its original position throughout the life of the product. (See Safety Labeling Section, page 2).

NOTE: Inspect equipment for protective coatings (i.e. paint) that have deteriorated or been removed. Prepare affected area and reapply protective coating as required.

NOTE: At every lubrication period, inspect the edge of dock for any damaged or worn parts. If any damaged or worn parts are found, discontinue use of the edge of dock and/or repair immediately.

Hydraulic Oil:

Weekly: Once a week, or after repetitive operation, the cylinder should be extended to its maximum stroke. This will get rid of cylinder oil seepage build-up and lubricate the upper cylinder barrel.

Monthly: The recommended lubrication service interval is every 30 days or at a greater frequency as required in severe environments. HVI-22 hydraulic oil is recommended and EP2 Multipurpose Grease or equivalent is recommended for grease points. (See Figure 13: Lubrication on page 20 for lubrication points).

The oil level should be checked once a month. When the edge of dock is fully lowered, the oil level in the reservoir of a 1 or 3 hp power unit should be approximately 2 – 3 inches from the top. The oil should be changed once a year under normal operating conditions. The required Hydraulic Oil is HVI-22. It is strongly urged that a maintenance log be maintained with the dates of monthly inspections, the name of the inspector and results of the inspection.

Seasonal or Semiannual Maintenance: Change hydraulic fluid for ambient temperature changes if appropriate. Check the fluid reservoir to see if there is any evidence of accumulated condensation creating water contamination. The fluid will appear "milky" and light pink in color. Water accumulation will damage the hydraulic pump.

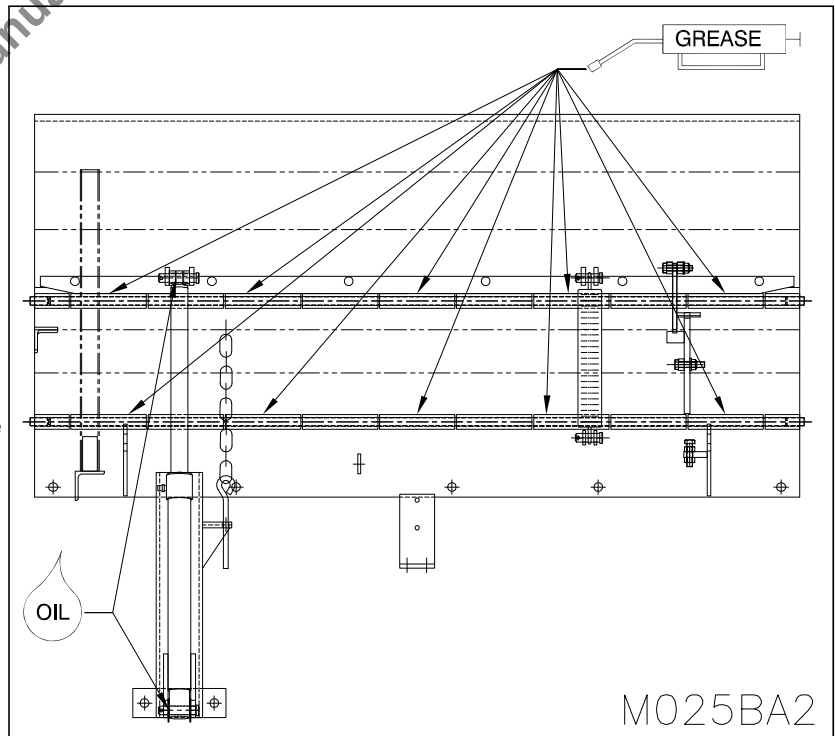

Figure 13: Lubrication

NOTICE

The standard hydraulic oil supplied with the equipment is HVI-22 Hydraulic fluid. This fluid is suitable for use from approximately -30° C (-22F) minimum to +35°C (+95°F) unless otherwise specified on the specific equipment order. The equipment can be operated in temperatures slightly higher and lower than the temperatures stated on an intermittent basis. Operating the equipment for extended periods of times at temperatures higher or lower than the stated temperatures above may result in functional issues for the equipment. It may also result in damage and issues to hydraulic components. As the actual temperature the equipment is used in moves further away from the recommended temperature range the concern points increase. Abuse and overuse in this regard will void all warranty. The standard replacement Hydraulic Fluid is HVI-22 hydraulic fluid which accommodates the temperature range stated above. There are special hydraulic fluids available to accommodate temperatures that are consistently and or significantly lower or higher than those stated above. In many cases the use of these types of specialty fluids will result in the requirement for hydraulic fluid changes during seasonal yearly temperature changes.

Recommended for colder temperatures is Hydraulic Fluid 5606A
Recommended for warmer temperatures is Hydraulic Fluid HVI-32

If the hydraulic oil provided from the factory is non-standard, refer to the hydraulic reservoir fluid label which will specify the particular oil requirements.

Note: When approaching or operating in temperature beyond the high and low temperature ranges of the ratings for the hydraulic fluids, there may be some adverse effects to the functionality of the equipment. This could include (but not be limited to) harmonics and vibration of cylinders, inhibited or reduced equipment performance and function, slower cycle times, hydraulic leaks unwanted activation of velocity fuses. To address concerns of this nature a change in hydraulic fluid or a special oil additive may be required. Contact your Pentalift representative for more information.

Note: The remote installation location of the hydraulic power unit can also help address concerns with hydraulic fluid temperature ranges. For example if the equipment is purchased with a remote power unit, the power unit can be installed in a warmer (indoor) location. In this arrangement, even though the main equipment and it's hydraulic components maybe exposed to more extreme temperatures, the hydraulic power unit and the hydraulic fluid stored in it will be exposed to and therefore absorb the more moderate and desirable internal temperature. During operation the oil in the power unit will quickly mix with the oil in the equipment and will typically mix to a more desirable temperature level.

Note: That if the hydraulic power unit is installed in a pit, as is usually the case for dock levelers, the pit will have moderating effect on the temperature the hydraulic power unit is exposed to. This should be part of the consideration of hydraulic fluid selection.

REPLACEMENT PARTS

USE ONLY GENUINE PENTALIFT REPLACEMENT PARTS



To ensure proper functioning, durability and safety of the product, only genuine pentalift replacement parts must be used. Altering the product from its original manufactured configuration must not be done. Pentalift equipment Corporation disclaims all liability for failure to comply with this warning. Warranties are specifically disclaimed in the event the purchaser fails to comply with this warning.

To expedite order processing when ordering parts, provide the following information to your Pentalift representative:

1. Model and Serial Number of equipment.
2. Part Number, Description and Quantity.
3. Shipping Instructions.

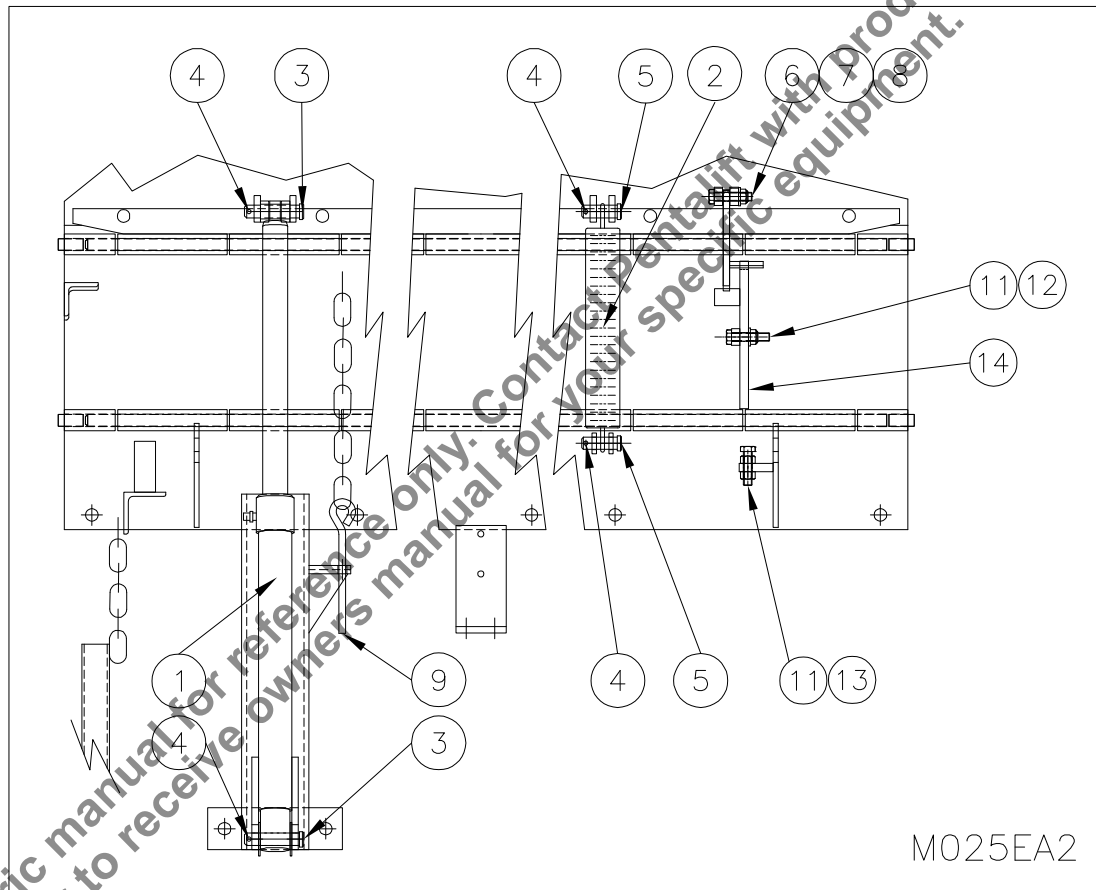

Figure 14: Replacement Parts

<u>Item #</u>	<u>Part No.</u>	<u>Description</u>	<u>Item #</u>	<u>Part No.</u>	<u>Description</u>
1	800-8763	Lift Cylinder	8	300-8819	Lip Lock
2	302-0566	Return Spring	9	087-0011	Eye Bolt
3	302-0392	Clevis Pin	10	052-0055	Grease Fitting (Not Shown)
4	080-0001	Spring Pin	11	072-0332	Hex Head Bolt
5	302-0410	Lip Clevis Pin	12	070-0063	Nylock Nut
6	072-0332	Socket Head Cap Screw	13	070-0006	Hex Nut
7	070-0063	Nylock Nut	14	800-8804	Lip Lock Actuating Lever

NOTE: State Model # and Serial # when ordering replacement parts.

LIST OF ILLUSTRATIONS

Figure 1: Safety Labels and Decals	2
Figure 2: Load Specification	4
Figure 3: Mounting Channel	5
Figure 4.1: Lag Plate - 96" LONG	7
Figure 4.2: Lag Plate - 120" LONG	7
Figure 5: Welding at Final Installation	9
Figure 6: DB13 Installation	11
Figure 7: PLB414AF Installation	11
Figure 8: PLB414 Installation	12
Figure 9: Operation	14
Figure 10: Edge of Dock Unsupported	15
Figure 11: End Loading/ Unloading	16
Figure 12: Maintenance Stand	17
Figure 13: Lubrication	20
Figure 14: Replacement Parts	22

Generic manual for reference only. Contact Pentalift with product serial number to receive owners manual for your specific equipment.

PENTALIFT EQUIPMENT CORPORATION WARRANTY

WARRANTY

Pentalift Equipment Corporation expressly warrants that any product manufactured by **Pentalift Equipment Corporation** will be free from defects in material and workmanship under normal use for a period of one (1) year from the date of shipment of the equipment, provided the original purchaser maintains and operates the product in accordance with proper procedures. In the event the product proves defective in material or workmanship, **Pentalift Equipment Corporation** will at its option:

1. Replace the product or the defective portion thereof without charge to the purchaser; or
2. Alter or repair the product; on site or elsewhere, as **Pentalift Equipment Corporation** may deem advisable, without charge to the purchaser.

The warranty stated in the previous paragraph is that expressed by **PENTALIFT EQUIPMENT CORPORATION** AND IS IN LIEU OF ALL GUARANTEES AND WARRANTIES, EXPRESSED OR IMPLIED BY ANYONE OTHER THAN **PENTALIFT EQUIPMENT CORPORATION**. This warranty does not cover any failure caused by improper installation, misapplication, overloading, abuse, negligence, or failure to lubricate and adjust or maintain the equipment properly and regularly. Parts requiring replacement due to damage resulting from abuse, improper operations, improper or insufficient lubrication, lack of proper protection or vehicle impact are not covered by this warranty. **Pentalift Equipment Corporation** assumes no responsibility or liability for:

1. Consequential damages of any kind which result from use or misuse of the equipment.
2. Damage or failure resulting from the use of unauthorized replacement parts.
3. Damage or failure resulting from modification of the equipment.
4. Damage resulting from the misuse of the equipment.

THERE ARE NO WARRANTIES, EXPRESSED OR IMPLIED, WHICH EXTEND BEYOND THE DESCRIPTION ON THE FACE HEREOF, AND THERE IS NO WARRANTY OF MERCHANTABILITY OR OF FITNESS FOR A PARTICULAR PURPOSE.

Pentalift Equipment Corporation warranties extend only to the original product itself. In no event shall **Pentalift Equipment Corporation** be responsible for or liable to anyone, including third parties, for special, indirect, collateral, punitive, incidental or consequential damages, even if **Pentalift Equipment Corporation** has been advised of the possibility of such damages. Such excluded damages include, but are not limited to, loss of good will, loss of profits, loss of use, interruption of business or other similar indirect financial loss.

Pentalift Equipment Corporation DISCLAIMS all liability arising out of the workmanship, methods and materials used by the installer.

Pentalift Equipment Corporation DISCLAIMS all liability for premature product wear, product failure, property damage or bodily injury arising from improper installation and application.

Pentalift Equipment Corporation will not accept any warranty for which the original purchaser does not notify **Pentalift Equipment Corporation's** Warranty Department of the defect within ninety (90) days after the product defect is discovered. A fully completed Product Registration Card is required prior to the review or processing of any warranty requests or claims.

WARRANTIES, whether expressed or implied, relating to workmanship and materials used in connection with the installation of **Pentalift Equipment Corporation** products are specifically DISCLAIMED.

WR001R02



P.O. Box 1510, Buffalo, NY, U.S.A. 14240-1510
Phone: (519) 763-3625 □ FAX (519) 763-2894
21 Nicholas Beaver Rd, Puslinch, Ontario, N0B 2J0 Canada
Phone: (519) 763-3625 □ FAX (519) 763-2894

NOTE: All Pentalift Equipment Corporation products are subject to design improvement through modification without notice.