



**PENTALIFT EQUIPMENT CORPORATION**

# **PRO SERIES LIFT TABLE OWNERS MANUAL**

**MODEL NUMBER :** \_\_\_\_\_ **SERIAL NUMBER :** \_\_\_\_\_

**CAPACITY:** \_\_\_\_\_

Individual Model Number(s) and Serial Number(s) must be filled out by the user for future reference.

### **This manual is an important document.**

It shall be kept with the machine or located where readily available to operators and maintenance personnel for reference purposes. Do not install, operate or service this product unless you have read and fully understand the entire contents of this manual. Failure to do so may result in property damage, bodily injury or death. Keep this manual in a safe place for future reference.

**Pentalift Equipment Corporation  
21 Nicholas Beaver Rd  
Puslinch, ON N0B 2J0  
Phone: 519-763-3625  
Fax: 519-763-2894  
Parts Phone: 519-763-3625 Extension 625  
Ask for Parts Department**

**Pentalift Equipment Corporation provides an owners manual when equipment is shipped. Additional manuals are available at \$25.00 each.**

**IMPORTANT:** The owners manuals that are provided on Pentalift Equipment Corporations website are generic in nature. They are provided for general information only. For all purposes, only the owners manual that is specific to the equipment should be referenced and relied on. In order to receive the specific owners manual for specific Pentalift equipment, please contact your Pentalift representative and supply the specific serial number(s) for the equipment the manual is required for. Do not rely on the information in the generic owners manuals provided through the website as it may not be appropriate for your specific Pentalift equipment.

*Generic manual for reference only. Contact Pentalift with product serial number to receive owners manual for your specific equipment.*

# PRODUCT REGISTRATION

# PRODUCT REGISTRATION



### PRODUCT REGISTRATION CARD

To validate warranty and to advise of product updates please complete the following information and return to

**Pentalift Equipment Corporation**

To validate warranty on-line go to: [www.pentalift.com](http://www.pentalift.com)

#### End User Information

*Company Name:		
Contact *First Name:	*Last Name:	Title:
*Mailing Address:		
*City:	*State/Prov.	*Zip/Postal Code:
*Phone: ( ) -	Fax: ( ) -	Email:
Check Products Purchased: <input type="checkbox"/> Levelers, <input type="checkbox"/> Vehicle Restraints, <input type="checkbox"/> Seals/Shelters, <input type="checkbox"/> Elevating Docks, <input type="checkbox"/> Lift Tables		
*Serial Number(s):	Invoice # (if available):	
Dealer Name:	Sales Rep.:	
Manual Verification *Manual Number:		

\*Indicates information that must be provided.

Please return to:

Pentalift Equipment Corporation  
P.O. Box 1510,  
Buffalo, NY 14240-1510

or

Pentalift Equipment Corporation  
21 Nicholas Beaver Rd  
Puslinch, Ontario N0B 2J0

Attention: Service Department

Or Fax to (519) 763-2894

# SAFETY INFORMATION AND WARNINGS



READ THESE SAFETY PRACTICES BEFORE INSTALLING, OPERATING OR SERVICING THE EQUIPMENT. FAILURE TO FOLLOW THESE SAFETY PRACTICES MAY RESULT IN PROPERTY DAMAGE, BODILY INJURY OR DEATH.

THE OPERATION OF THIS EQUIPMENT IS SUBJECT TO CERTAIN HAZARDS THAT CAN BE PROTECTED AGAINST ONLY BY THE EXERCISE OF CARE AND COMMON SENSE AND NOT BY MECHANICAL MEANS. IT IS, THEREFORE, ESSENTIAL TO HAVE COMPETENT, QUALIFIED OPERATORS TRAINED IN THE SAFE OPERATION AND CARE OF THIS TYPE OF EQUIPMENT. ALL PERSONNEL MUST COMPLETELY UNDERSTAND THIS SAFETY INFORMATION BEFORE WORKING ON OR NEAR THIS EQUIPMENT.



**DANGER** indicates an imminently hazardous situation which, if not avoided, will result in death or serious injury.



**WARNING** indicates a potentially hazardous situation which, if not avoided, could result in death or serious injury.



**CAUTION**, used with the safety alert symbol, indicates a potentially hazardous situation which, if not avoided, could result in minor or moderate injury.

## NOTICE

**NOTICE** is used to address practices not related to personal injury.



Before doing any installation, maintenance, inspection or trouble shooting, barricade all areas from traffic around the work area inside (and outside if applicable) for safety and post appropriate warning signs.



Arc flash and shock hazard PPE (personal protection equipment) required. De-energize equipment before working on or inside. Do not open cover without appropriate PPE. Refer to NFPA 70E for PPE requirements. This panel may contain more than one power source. Hazardous voltage will cause severe injury or death.



Before doing any electrical work, be certain that the power is disconnected with a fused disconnect, properly tagged and locked out. Fused disconnect and lockout device (supplied and installed by others) must meet with all applicable codes and regulations. All electrical work must be performed by a qualified electrician in accordance with all applicable codes and regulations.



It is the responsibility of others to ensure the proper mounting of any wall mounted equipment such as remote power units, control panels and light packages and to ensure that the mounting surface is capable of fully supporting the loads generated by the equipment.

1. NEVER EXCEED THE MAXIMUM RATED CAPACITY OF THE TABLE. (i.e., the maximum load for a 4000 lbs. rated unit is 4000 lb, evenly distributed, with the load center at the center of the platform.) Refer to the specification plate (See "Figure 2, Safety Label and Decal Locations" on page 3) for each lift table's particular ratings.
2. Equipment must be lagged to the floor.
3. Do not apply shock loads to the unit. (I.e. Do not drop loads onto the platform, lower loads onto the platform at a high rate of speed, stop unit abruptly or jog in lower range of travel.)
4. The platform surface must be kept clean and free from oil, debris, etc. Keep debris, etc. from underneath the unit.
5. Keep any obstructions and personnel clear of the lift table and load and their operating path to eliminate injury and/or damage. Avoid or eliminate any and all potential pinch points.
6. Prior to each use, ensure lift table and load does not create pinch points during operation when located adjacent to or near other equipment or structures.

7. Never use the unit for lifting personnel unless it has been suitably designed and manufactured for that purpose by Pentalift Equipment Corporation.
8. Anyone using or in the vicinity of this equipment must wear protective footwear with steel toes.
9. Do not operate, use, maintain or install this equipment if you are impaired in any manner.
10. All electrical, hydraulic and/or pneumatic lines must be carefully routed to prevent them from being pinched or severed.
11. Regular inspection and maintenance must be performed to keep the equipment in proper operating condition. Pay particularly close attention to all hoses and/or wires in order to detect possible cracks or wear. Always follow the instructions as per the 'HOW TO SUPPORT THE LIFT TABLE DURING INSPECTION AND OR ROUTINE MAINTENANCE ' section in this manual (See page 12) prior to performing any activity within the operating path of the lift table.
12.  Do not operate this equipment if you believe that any part of it might be damaged or malfunctioning.
13. Assure that the Owner's Manual is at all times accessible to anyone who may require it.

Generic manual for reference only. Contact Pentalift with product serial number to receive owners manual for your specific equipment.

# OWNER RESPONSIBILITY

**12.1.** *It is the responsibility of the user/purchaser to advise the manufacturer where deflection may be critical to the application.*

**12.2. Inspection and Maintenance**

*The lift shall be inspected and maintained in proper working order in accordance with the manufacturer's operating/maintenance manual and safe operating practices.*

**12.3. Removal from Service**

*Any lift not in safe operating condition such as, but not limited to excessive leakage, missing rollers, pins or fasteners, any bent or cracked structural members, cut or frayed electric, hydraulic or air lines, damaged or malfunctioning controls or safety devices, etc. shall be removed from service until it is repaired to the original manufacturer's standards.*

**12.4. Repairs**

*All repairs shall be made by qualified personnel in conformance with the manufacturer's instructions.*

**12.5. Operators**

*Only trained personnel and authorized personnel shall be permitted to operate the lift.*

**12.5.1. Before Operation**

*Before using the lift, the operator shall have:*

- *Read and/or have explained, and understood, the manufacturer's operating instructions and safety rules.*
- *Inspected the lift for proper operation and condition. Any suspect item shall be carefully examined and a determination made by a qualified person as to whether it constitutes a hazard. All items not in conformance with the manufacturer's specification shall be corrected before further use of the lift.*

**12.5.2. During Operation**

*The lift shall only be used in accordance with the manufacturer's operating/maintenance manual.*

- *Do not overload the lift.*
- *Ensure that all safety devices are operational and in place.*

**12.6. Modifications or Alterations**

*Modifications or alterations of industrial scissors lifts shall be made only with written permission of the original manufacturer. These changes shall be in conformance with all applicable provisions of this standard and shall be as safe as the equipment was before modification. These changes shall also satisfy all safety recommendations of the original manufacturer for the particular application of the lift.*



Unless specifically agreed to in writing by Pentalift Equipment Corporation at the time the equipment is ordered and prior to the equipment's manufacture, this equipment is sold as a complete package. It is not to be altered, changed or added to in any way or form, in its configuration and function, without the written permission of Pentalift Equipment Corporation.

If requested by a customer, Pentalift Equipment Corporation is not supplying all or some of the power unit and / or control components for the equipment's application. The power unit and controls constitute important safety and functional aspects of the equipment. It is the customer's responsibility to address the operational and safety issues associated with providing the required controls and power units to satisfy the operational and safety requirements of the equipment.

The customer's decision to supply all or some of these components indicates that the customer is taking full responsibility for any and all possible operational, safety and liability issues associated to the product and its configuration. The customer also agrees to absolve Pentalift Equipment Corporation from any and all possible operation, safety and liability issues.

# EXPLANATION OF CALIFORNIA'S PROPOSITION 65

The product(s) reference by this manual comply with California's Proposition 65 (Prop 65).

Prop 65 is a voter initiative passed in 1986. This law regulates substances officially listed by California as having a 1 in 100,000 chance of causing cancer over a 70-year period or birth defects or other reproductive harm in two ways. The first statutory requirement of Prop 65 prohibits businesses from knowingly discharging listed substances into drinking water sources, or onto land where the substances can pass into drinking water sources. The second prohibits businesses from knowingly exposing individuals to listed substances without providing a clear and reasonable warning. There are several states that regulate or list similar substances. The chemicals do not need to be in liquid form; the consumer only needs to be exposed to them at certain levels.

On August 30, 2016 California adopted amendments to the regulations that govern clear and reasonable warnings under Prop 65. The new regulation took effect August 30, 2018.

A warning label is required which permits our products to be used in California after August 30, 2018. The label need only be in English language. The label meets the guidelines of ANSI Z535.4 which we follow. There is one size (1" h x 2 1/2" w) for all products. It is placed in the proximity of other precautionary labels. A minimum of one label per machine. Proving every listed chemical present would result in levels (micro-grams/day) below the Prop 65 requirement is impractical. To avoid the complication for having labels which are specific to the most prevalent chemical in each unique model the truncated label is acceptable under the California law. In order to use the truncated label, the label must be on the product.



This is the warning label which meets the Prop 65 requirements..

This abbreviated label can also be used for the pre-sale notification. For this responsibility to the law advice is added to our terms and conditions of sale. The owner's manual also supports the notification using this notice:

Additional detail about Prop 65 is available at <https://www.p65warnings.ca.gov/>

# TABLE OF CONTENTS

PRODUCT REGISTRATION .....	I
SAFETY INFORMATION AND WARNINGS .....	II
OWNER RESPONSIBILITY .....	IV
EXPLANATION OF CALIFORNIA'S PROPOSITION 65 .....	V
TABLE OF CONTENTS .....	1
SAFETY LABELING .....	2
SURFACE INSTALLATION: .....	5
INSTALLATION INSTRUCTIONS .....	5
PREPARATION PRIOR TO INSTALLATION .....	5
INITIAL SET-UP: .....	6
PIT INSTALLATION: .....	7
INITIAL SET-UP: .....	8
ELECTRICAL REFERENCE - 1.5 HP .....	9
ELECTRICAL REFERENCE - 3 HP .....	9
ELECTRICAL REFERENCE - 5 HP .....	10
OPERATING INSTRUCTIONS .....	11
HOW TO SUPPORT THE LIFT TABLE DURING INSPECTION AND OR ROUTINE MAINTENANCE .....	12
MAINTENANCE AND LUBRICATION .....	14
TROUBLE SHOOTING GUIDE .....	16
REPLACEMENT PARTS .....	18
LIFT CYLINDER PARTS .....	18
LIFT TABLE PARTS .....	20
ROTATING TOP .....	21
DUAL FOOT PEDAL CONTROL .....	22
LIMIT SWITCH .....	22
CONTROL BOX DRAWINGS .....	23
LIST OF ILLUSTRATIONS .....	26
PENTALIFT EQUIPMENT CORPORATION WARRANTY .....	27

Generic manual for reference only. Contact Pentalift with product serial number to receive owners manual for your specific equipment.

# SAFETY LABELING

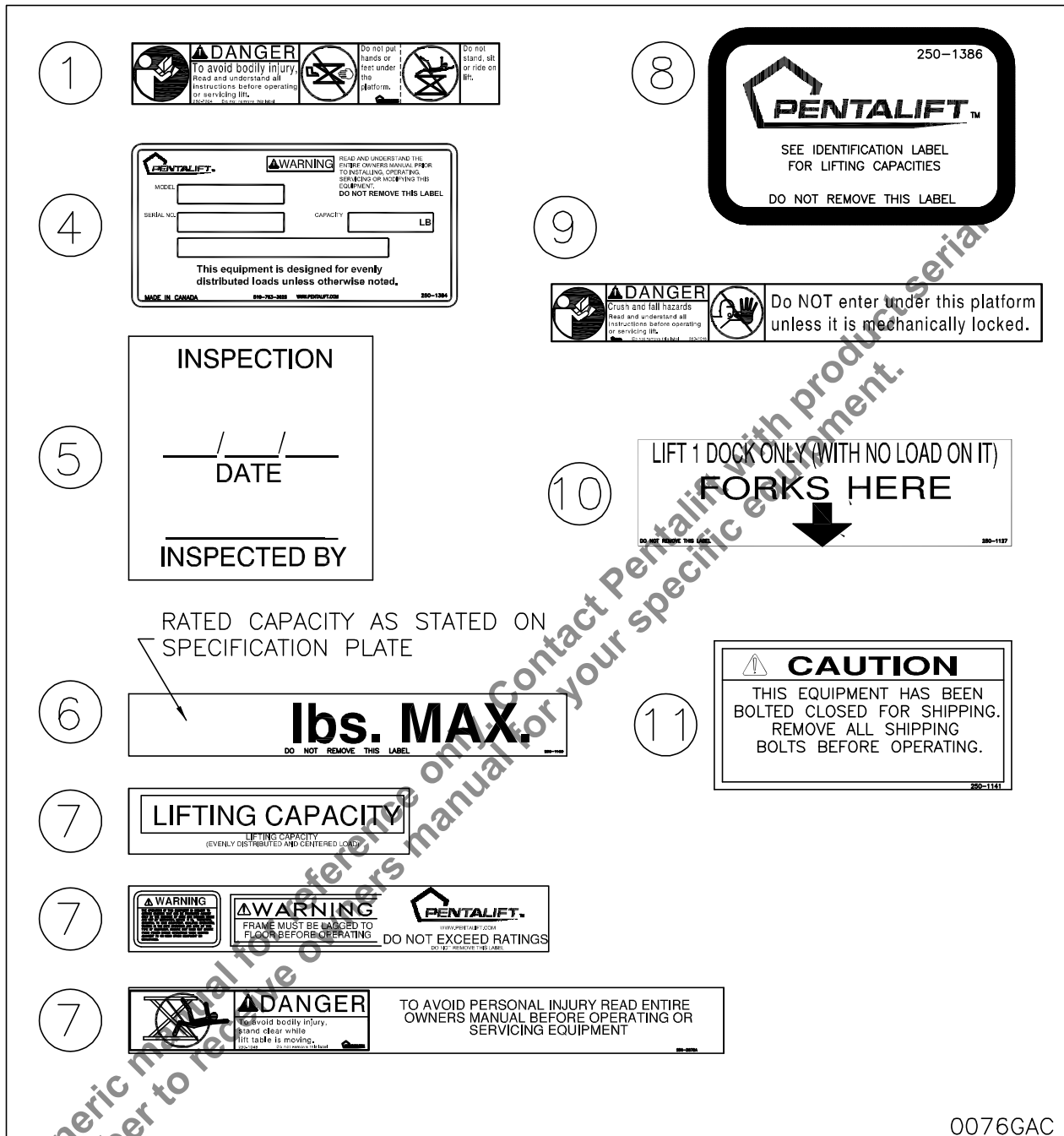
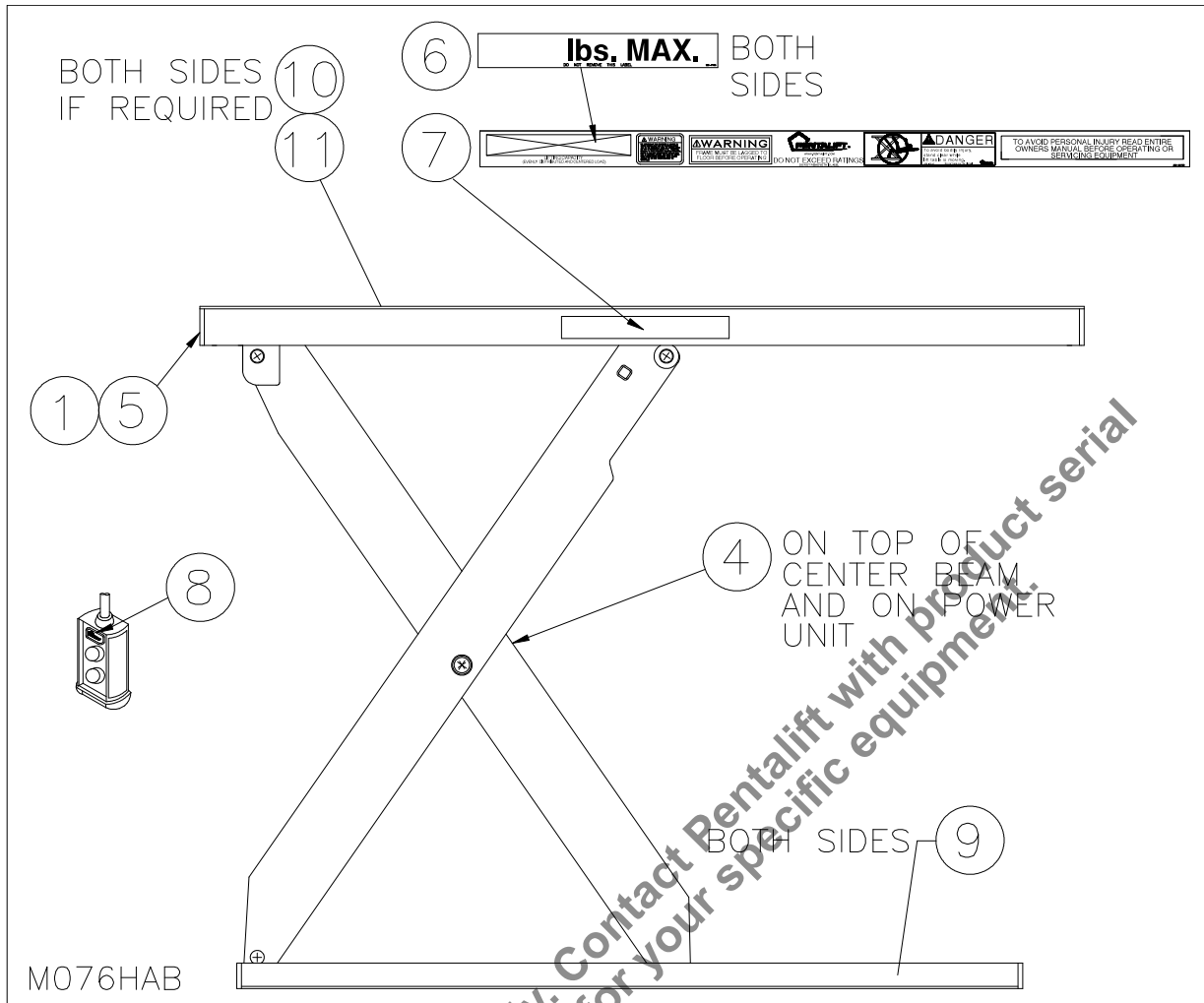

Figure 1: Safety Labels and Decals



**Figure 2: Safety Label and Decal Locations**

Be sure that all labeling is in place and intact when unit is received. If any of the safety labels or decals are missing or illegible, contact your Pentalift representative for immediate replacement.

**NOTE:** In some instances, product configuration and/or product options may dictate that the product labels will not be placed as indicated on drawing (Figure 2 ). Different label locations will be selected at the factory, when required, to avoid an impaired view of the labels. Note the label locations as supplied on the product, when it is received to accommodate future label replacement requirements.

**NOTE:** It is the owner's responsibility to assure that all safety labeling remains legible and is in its original position throughout the life of the product. It is also the owner's responsibility to assure that all labels are and will continue to be readily visible to the operators and people working with and around the equipment. If the visibility of any label is compromised for any reasons then; either 1) Rectify the situation to allow the label to be readily visible 2) Order replacement label(s) from Pentalift for installation in a location that does facilitate complete visibility. If any of the safety labels or decals are missing or illegible, contact your Pentalift representative for immediate replacement. Inspection shall be done during regular maintenance and lubrication (See "MAINTENANCE AND LUBRICATION" on page 14).

To re-order labels and decals, use the following part numbers:

<u>Item</u>	<u>Part No.</u>	<u>Qty/Unit</u>	<u>Description</u>
1	250-7004	1	"WARNING - DO NOT STAND..."
4	250-1384	2	SPECIFICATION PLATE
5	250-1148	1	FINAL INSPECTION
6	SEE NOTE	2	CAPACITY LABEL
7	250-2075	2	SAFETY STRIPE
8	250-1386	1	PUSH BUTTON LABEL
9	250-7015	2	"DANGER... DO NOT WORK UNDER..."
10	250-1127	2	"FORKS HERE"
11	250-1141	2	"... BOLTED CLOSED..."

**NOTE:** State Model # and Serial # when ordering replacement parts.

Generic manual for reference only. Contact Pentalift with product serial number to receive owners manual for your specific equipment.

# INSTALLATION INSTRUCTIONS



Do not install, operate or service this product unless you have read and fully understand the entire contents of this manual. Failure to do so may result in property damage, bodily injury or death.

---

## IMPORTANT PREPARATION PRIOR TO INSTALLATION

---

Perform installation instructions in the same sequence as they are listed below.



Before doing any installation, maintenance, inspection or trouble shooting, barricade all areas from traffic around the work area inside (and outside if applicable) for safety and post appropriate warning signs.



Before doing any electrical work, be certain that the power is disconnected with a fused disconnect, properly tagged and locked out. Fused disconnect and lockout device (supplied and installed by others) must meet with all applicable codes and regulations. All electrical work must be performed by a qualified electrician in accordance with all applicable codes and regulations.



Arc flash and shock hazard PPE (personal protection equipment) required. De-energize equipment before working on or inside. Do not open cover without appropriate PPE. Refer to NFPA 70E for PPE requirements. This panel may contain more than one power source. Hazardous voltage will cause severe injury or death.



MAKE SURE LIFTING AND SLINGING DEVICES ARE OF SUFFICIENT CAPACITY, USED IN THE CORRECT MANNER AND ARE IN GOOD WORKING ORDER. ALL LIFTING, POSITIONING AND INSTALLATION, AS WELL AS THE BREAK-IN AND PERFORMANCE CHECK MUST BE DONE BY QUALIFIED PERSONNEL TRAINED AND EXPERIENCED IN NECESSARY SAFETY PROCEDURES.



BE SURE ALL HYDRAULIC FITTINGS ARE RATED FOR HYDRAULIC SYSTEMS THAT MAY PEAK OUT AT 4000PSI. HARDWARE STORE ITEMS CAN BURST AT 150PSI. ONLY BUY REPLACEMENT PARTS FROM PENTALIFT.



It is the responsibility of others to ensure the proper mounting of any wall mounted equipment such as remote power units, control panels and light packages and to ensure that the mounting surface is capable of fully supporting the loads generated by the equipment.

## SURFACE INSTALLATION:

1. Make sure the installation surface is clean, level and flat before installing the unit. A slight slope from fixed end to roller end is not a problem, but a side to side slope will cause premature wear on all moving parts of the lift.
2. The installation surface must be capable of supporting any loads that will be applied to it.
3. Move the unit to the installation location.
4. Remove any shipping materials, bolts and hardware.
5. If the power unit is remote, mount the power unit in the desired location and connect the hydraulic hoses. Ideally, the reservoir should be mounted on a wall approximately 6 1/2 feet above the ground.

Run the hydraulic lines from the power unit to the lift and flush with clean fluid before connecting the lines. If the lines must be pushed through conduits or enclosures, be sure to cap the lines to prevent contaminants from entering the hose.

6. Connect the appropriate supply voltage to the motor control panel. (Refer to the **WIRING DIAGRAM** located inside the motor control panel and the electrical specification label located on the side of the motor control panel).

**NOTE: All wiring must be performed by a qualified electrician in accordance with all applicable codes.**

**NOTE:**

- a. On 3 phase units ensure phase polarity is correct. Incorrect polarity will cause the lift table not to lift. The motor will run backwards resulting in cavitation and possible damage to the pump.
  - b. To prevent tripping the motor overload relay the motor requires the specified voltage at the motor while the motor is working under full load. If there is a problem confirm that the supply conductors are sufficient in relation to the run length. See ELECTRICAL REFERENCE - 1 ½ HP Chart on page 9. (Consult all applicable electrical codes as well.)
7. Raise the unit to its maximum height and then fully lower. Repeat the cycle a minimum of three times. This allows the table to realign itself after shipping.
  8. If required, level the unit on both sides by shimming under the frame angle for the full roller travel, lower fixed end clevises, and lag brackets. (See "Figure 4: Shim Positions" on page 8)
  9. Fully raise the lift table and block scissor mechanism following the instructions in HOW TO SUPPORT THE LIFT TABLE DURING INSPECTION AND OR ROUTINE MAINTENANCE. (See page 12)
  10. When installing onto a concrete floor, lag the unit to the floor with recommended fasteners, 5/8" Dia. x 4 ½" long wedge anchors with a minimum shear value of 12,900 lbs. (5 850 kg), and tension value of 10,200 lbs. (4,630 kg). Torque to manufacturer specifications. If the mounting surface is not concrete, utilize a fastener to suit the structural values indicated and appropriate for the mounting surface.
  11. Weld all shims together and then to the lift table frame.
  12. Check the oil in the power unit reservoir and add if necessary (See "MAINTENANCE AND LUBRICATION" on page 14)
  13. Clean up any debris and/or spilled oil from the area. Fluid spills may later be misinterpreted as new fluid leaks. Check all hydraulic fittings for leaks.
  14. Ensure the toe sensor (if equipped) is functional. NOTE: The toe sensor option is an electrical safety device with an actuator suspended beneath the platform which halts downward travel of the lift table if it contacts with an obstruction. (This feature is not functional in the event of hydraulic failure.)
  15. Meet with the facility manager or maintenance foreman and turn over this maintenance manual with the reminder that no one is allowed to operate the unit unless they fully understand the entire owners manual.

**INITIAL SET-UP:**

1. It is important to purge air from the hydraulic system. To do this, raise the unit to its maximum raised height and allow the power unit to run for a minimum of 30 seconds additional time. Fully lower the unit. Discontinue use of the unit for 20 minutes to allow air to dissipate from the oil in the reservoir.

**NOTE:** Units equipped with an up travel limit switch will not reach their maximum raised height unless the limit switch is removed. The up travel limit switch must be removed to purge the air. **DO NOT remove the up travel limit switch until first ensuring there are no obstructions in the operating path of the equipment.** After the air has been purged, lower the lift table to its desired raised height and reinstall the limit switch.

## PIT INSTALLATION:

1. Confirm that the table has been built for pit installation with either bevel toe guards or straight toe guards with toe sensors (See “Figure 3: Platform Safety Features” on page 7). If uncertain that your unit is suitable for pit installation contact your Pentalift representative.
2. Make sure the installation surface is clean, level and flat before installing the unit. A slight slope from clevis end to roller end is not a problem, but a side to side slope will cause premature wear on all moving parts of the lift. Tighten the lag bolts.
3. The installation surface must be capable of supporting any loads that will be applied to it.
4. Hoist the lift table into the pit. NOTE: If the power unit is remote, assure that the hydraulic hose is fed through the appropriate conduit. If the power unit is self-contained, assure the temporary wire is routed out of the pit for easy hook-up.

**NOTE: The temporary wires supplied are intended to be used for lifting the platform for the initial installation only. Once the maintenance stand is in position, the temporary wires are to be removed from both the power supply and the lift table. Permanent wiring must be installed immediately.**

**NOTE: The temporary wires should be connected only if they meet the requirements of the applicable local electrical codes. If they do not, the electrician should rewire to meet all applicable codes prior to applying any electrical power.**

5. Square the lift table platform in the pit, leaving approximately 1” space all around the pit edge.
6. Remove any shipping materials, bolts and hardware. If the power unit is remote, mount the power unit in the desired location and connect the hydraulic hoses. Ideally, the reservoir should be mounted on a wall approximately 6 1/2 feet above the ground.

Run the hydraulic lines from the power unit to the lift and flush with clean fluid before connecting the lines. If the lines must be pushed through chases or enclosures, be sure to cap the lines to prevent contaminants from entering the hose.

7. Connect the appropriate supply voltage to the motor control panel. (Refer to the WIRING DIAGRAM located inside the motor control panel and the electrical specification label located on the side of the motor control panel.)

**NOTE: All wiring is to be performed by a qualified electrician in accordance with all applicable codes.**

### NOTE:

- a. On 3 phase units assure phase polarity is correct. Incorrect polarity will cause the lift table not to lift. The motor will run backwards resulting in cavitation and possible damage to the pump.
  - b. To prevent tripping the motor overload relay the motor requires the specified voltage at the motor while the motor is working under full load. If there is a problem confirm that the supply conductors are sufficient in relation to the run length. See ELECTRICAL REFERENCE - 1 ½ HP Chart on page 9. Consult all applicable electrical codes as well.
8. Raise the unit to its maximum height then fully lower. Repeat the cycle a minimum of three times. This allows the table to realign itself after shipping.
  9. Fully raise the lift table and block the scissor mechanism following the instructions in HOW TO SUPPORT THE LIFT TABLE DURING INSPECTION AND OR ROUTINE MAINTENANCE. (See page 12)

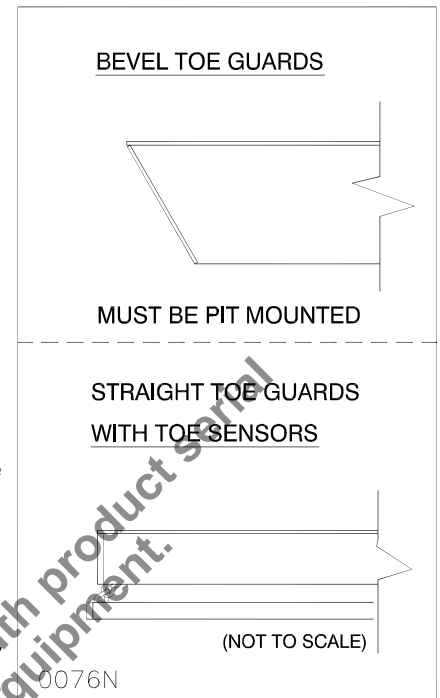

**Figure 3: Platform Safety Features**

10. If required, level the unit on both sides by shimming under the frame angle for the full roller travel, lower fixed end clevises, and lag brackets (See "Figure 4: Shim Positions" on page 8). Recheck the lift table for level and squareness in the pit.
11. Lag unit to the pit floor with recommended fasteners, 5/8" Dia. x 4 1/2" long wedge anchors with a minimum shear value of 12,900 lbs. (5 850 kg), and tension value of 10,200 lbs. (4 630 kg). Torque to manufacturer specifications.
12. Weld all shims together and then to the lift table frame.
13. Check the oil in the power unit reservoir and add if necessary (See "MAINTENANCE AND LUBRICATION" on page 14)
14. Clean up any debris and/or spilled oil from the area. Fluid spills may later be misinterpreted as new fluid leaks. Check all hydraulic fittings for leaks.
15. Ensure the toe sensor (if equipped) is functional. NOTE: The toe sensor option is an electrical safety device with an actuator suspended beneath the platform which halts downward travel of the lift table if it contacts with an obstruction. (This feature is not functional in the event of hydraulic failure.)
16. Meet with the facility manager or maintenance foreman and turn over this maintenance manual with the reminder that no one is allowed to operate the unit unless they fully understand the operating instructions.

#### INITIAL SET-UP:

17. It is important to purge air from the hydraulic system. To do this, raise the unit to its maximum raised height and allow the power unit to run for a minimum of 30 seconds additional time. Fully lower the unit. Discontinue use of the unit for 20 minutes to allow air to dissipate from the oil in the reservoir.

**NOTE:** Units equipped with an up travel limit switch will not reach their maximum raised height unless the limit switch is removed. The up travel limit switch must be removed to purge the air. **DO NOT remove the up travel limit switch until first assuring there are no obstructions in the operating path of the equipment.** After the air has been purged, lower the lift table to its desired raised height and reinstall the limit switch.

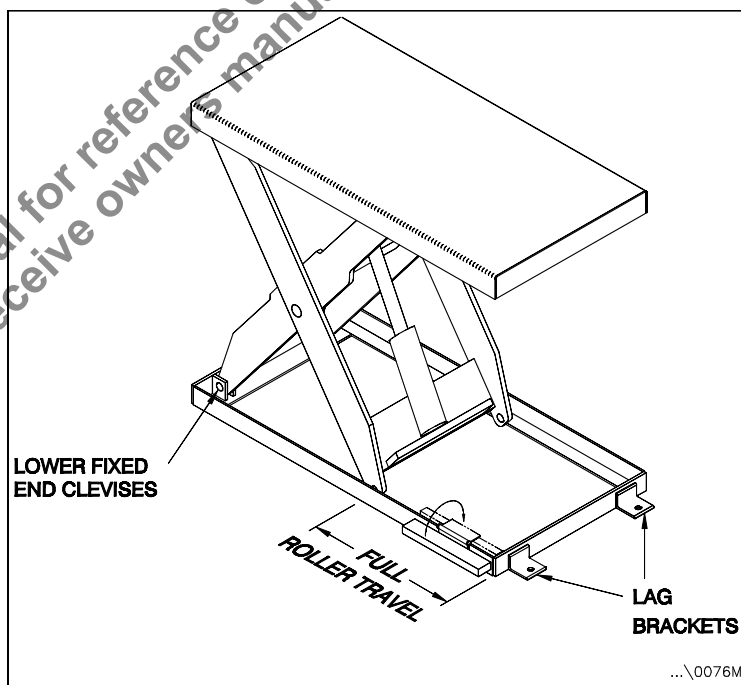

Figure 4: Shim Positions

Ensure that the thermal overload relay is set to match the full load current as shown on the motor name plate. Consult all applicable electrical codes.

<b>ELECTRICAL REFERENCE - 1.5 HP</b>							
Length of branch circuit which will have a 2% voltage drop at full load current (copper wire) ft/m.  The values given are intended to be a rough wiring guide only.  Be sure to check all local electrical codes before wiring.	AWG	115/1/60	230/1/60	230/3/60	380/3/50	460/3/60	575/3/60
	14		107 ft	209 ft	692 ft	838 ft	1455 ft
	12	43 ft	171 ft	333 ft	1100 ft	1332 ft	2313 ft
	10	68 ft	271 ft	529 ft	1749 ft	2118 ft	3676 ft
	8	108 ft	432 ft	842 ft	2782 ft	3368 ft	5847 ft
	6	172 ft	686 ft	1339 ft	4424 ft	5355 ft	9297 ft
Approximate Motor Current (full load)		16 A	8 A	5 A	2.5 A	2.5 A	1.8 A

<b>ELECTRICAL REFERENCE - 3 HP</b>							
Length of branch circuit which will have a 2% voltage drop at full load current (copper wire) ft/m.  The values given are intended to be a rough wiring guide only.  Be sure to check all local electrical codes before wiring.	AWG	115/1/60	230/1/60	230/3/60	380/3/50	460/3/60	575/3/60
	14		59 ft	87 ft	368 ft	106 ft	545 ft
	12		94 ft	139 ft	585 ft	169 ft	867 ft
	10	39 ft	150 ft	221 ft	930 ft	269 ft	1379 ft
	8	62 ft	238 ft	351 ft	1480 ft	428 ft	2193 ft
	6	98 ft	379 ft	558 ft	2353 ft	680 ft	3486 ft
Approximate Motor Current (full load)		28 A	14.5 A	12 A	4.7 A	6 A	4.8 A

## ELECTRICAL REFERENCE - 5 HP

Length of branch circuit which will have a 2% voltage drop at full load current (copper wire) ft/m.	AWG	115/1/60	230/1/60	230/3/60	380/3/50	460/3/60	575/3/60
		14			87 ft	228 ft	106 ft
	12			139 ft	362 ft	169 ft	867 ft
The values given are intended to be a rough wiring guide only.	10		103 ft	221 ft	575 ft	269 ft	1379 ft
	8		164 ft	351 ft	915 ft	428 ft	2193 ft
Be sure to check all local electrical codes before wiring.	6		261 ft	558 ft	1455 ft	680 ft	3486 ft
Approximate Motor Current (full load)			21 A	12 A	7.6 A	6 A	4.8 A

Generic manual for reference only. Contact Pentalift with product serial number to receive owners manual for your specific equipment.

# OPERATING INSTRUCTIONS

## **! DANGER**

USE BY UNTRAINED PEOPLE CAN RESULT IN PROPERTY DAMAGE, BODILY INJURY OR DEATH. READ, KNOW, AND OBEY ALL OPERATING INSTRUCTIONS AND SAFETY INFORMATION. FOLLOW ALL OSHA REGULATIONS REGARDING THE USE OF THIS EQUIPMENT. DO NOT USE THE EQUIPMENT IF ANY PART OF IT LOOKS BROKEN OR IF IT DOES NOT SEEM TO OPERATE PROPERLY. IF REPAIRS ARE NEEDED, CONTACT YOUR PENTALIFT REPRESENTATIVE.

## **! DANGER**

Do not install, operate or service this product unless you have read and fully understand the entire contents of this manual. Failure to do so may result in property damage, bodily injury or death.

**NOTE:** Read the **SAFETY INFORMATION AND WARNINGS** before operating the dock leveler. (See page iii)

1. Unless Pentalift specifies otherwise, Pentalift lift tables are designed for use with evenly distributed and centered loads.
2. Never exceed the rated capacity of the lift table as it is indicated on the specification plate. For specification plate location (See "Figure 2: Safety Label and Decal Locations" on page 3)

**NOTE:** The load is defined as the entire weight applied to the platform of the Lift Table including all conveyors, fixtures, etc. If you are unsure in any way as to the suitability of this product to your application, consult a Pentalift representative prior to using the Lift Table.

3. Do not apply shock loads to the unit. (i.e. Do not drop loads onto the platform, lower loads onto the platform at a high rate of speed, stop unit abruptly or jog in lower range of travel.) Do not load or unload the lift table while it is in motion. Properly secure all loads.
4. Never use the unit for lifting personnel unless it has been suitably designed and manufactured for that purpose by Pentalift Equipment Corporation.
5. Keep any obstructions and personnel clear of the lift table and load and their operating path to eliminate injury and/or damage. Avoid or eliminate any and all potential pinch points.
6. Prior to each use, ensure the lift table and load does not create pinch points during operation when located adjacent to or near other equipment or structures.
7. The platform surface must be kept clean and free from oil, debris, etc. Keep debris, etc. from underneath the unit.
8. When not in use, the unit **MUST** be in the fully lowered position.

### **Electro-Hydraulic Units:**

9. To raise the lift table, depress and hold the "UP" button or foot pedal. Allow the lift table to rise to the desired height and then release the button or foot pedal.
10. To lower the lift table, depress and hold the "DOWN" button or foot pedal and the unit will descend to its lowered position.

### **Units Equipped With A Manual Rotator:**

Rotating tops are designed to work with uniformly distributed loads only. The center of gravity of the load **MUST** be within 10" of the platform center.

# HOW TO SUPPORT THE LIFT TABLE DURING INSPECTION AND OR ROUTINE MAINTENANCE

## **⚠ DANGER**

THE BLOCKING PROCEDURES DESCRIBED BELOW ARE SUITABLE ONLY FOR THE INSPECTION, TROUBLE SHOOTING AND MAINTENANCE PROCEDURES DESCRIBED IN THIS MANUAL. THEY MAY NOT BE SAFE FOR OTHER INSPECTION, MAINTENANCE AND REPAIR PROCEDURES THAT MAY BE REQUIRED. CONTACT YOUR AUTHORIZED

PENTALIFT REPRESENTATIVE FOR DIRECTION PRIOR TO UNDERTAKING ANY ACTIONS OTHER THAN THOSE DESCRIBED IN THIS MANUAL. FAILURE TO PROPERLY ADHERE TO LIFT BLOCKING PROCEDURES IS TO RISK THE SUDDEN AND UNCONTROLLED DESCENT OF THE LIFT DURING MAINTENANCE OR INSPECTION. A FALLING LIFT CAN CAUSE SEVERE INJURY OR DEATH.

## **⚠ DANGER**

ONLY TRAINED AND QUALIFIED PERSONNEL SHALL PERFORM INSPECTION OR MAINTENANCE AND SERVICE PROCEDURES.

## **⚠ DANGER**

Before doing any installation, maintenance, inspection or trouble shooting, barricade all areas from traffic around the work area inside (and outside if applicable) for safety and post appropriate warning signs.

## **⚠ DANGER**

Before doing any electrical work, be certain that the power is disconnected with a fused disconnect, properly tagged and locked out. Fused disconnect and lockout device (supplied and installed by others) must meet with all applicable codes and regulations. All electrical work must be performed by a qualified electrician in accordance with all applicable codes and regulations.

## **⚠ DANGER**

Arc flash and shock hazard PPE (personal protection equipment) required. De-energize equipment before working on or inside. Do not open cover without appropriate PPE. Refer to NFPA 70E for PPE requirements. This panel may contain more than one power source. Hazardous voltage will cause severe injury or death.

## **⚠ DANGER**

PRIOR TO PERFORMING ANY ACTIVITY WITHIN THE OPERATING PATH OF THE LIFT TABLE, ALWAYS ENSURE THAT THERE IS NO LOAD ON THE LIFT TABLE AND THAT THE INSTRUCTIONS LISTED BELOW ARE FOLLOWED.

**NOTE: ANY LOADS INCLUDING CONVEYORS, FIXTURES, ETC., ARE TO BE REMOVED.**

The blocking procedure is as follows:

1. Raise the unloaded lift table to its maximum height.

**NOTE:** If the maximum height is insufficient to perform routine maintenance due to an optional limit switch that stops travel then bypass the limit switch electrically. Make sure that raising the lift table does not damage the limit switch and/or its activator in any way.

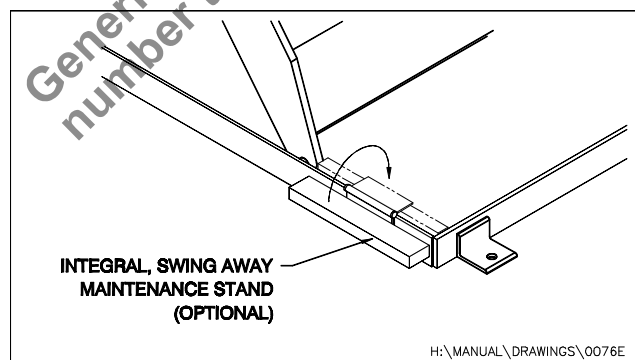

Figure 6: Optional Lift Table Supporting

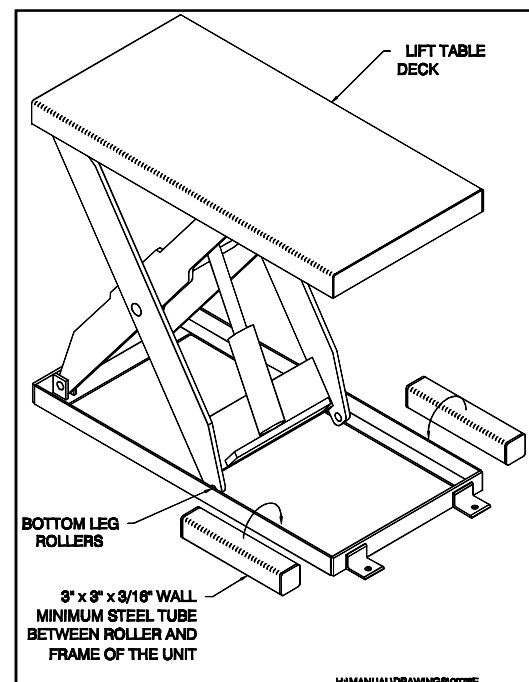

Figure 5: How to Support the Lift Table

2. On both sides of the lift table, insert equal lengths of 3" x 3" x 3/16" minimum wall thickness steel tube with welded steel end caps (minimum 3/16" thick), between the bottom leg rollers and the angle iron frame as shown in "Figure 5: How to Support the Lift Table" on page 12. **NOTE:** Measure the distance from the outside of the rollers to the inside of the frame. Cut the tubes 3/8" shorter than the measured distance. Make sure both tubes are equal in length. All steel tubing and end caps to be minimum (ASTM A-36) or (CSA G40.21).  
**NOTE:** A weld in hinged maintenance stand is available for after sale installation. See "Figure 6: Optional Lift Table Supporting" on page 12. Contact your Pentalift representative to order.
3. Lower the lift table until the leg rollers are securely supported by the steel tubes. Confirm the scissor legs are now securely blocked from downward movement.
4. Disconnect, properly tag and lock out power to the lift table prior to commencing inspection, trouble shooting or maintenance.

Generic manual for reference only. Contact Pentalift with product serial number to receive owners manual for your specific equipment.

# MAINTENANCE AND LUBRICATION

UNLESS OTHERWISE NOTED, THE FOLLOWING MAINTENANCE AND INSPECTION PROCEDURES SHOULD BE CONDUCTED AT A MINIMUM OF EVERY 30 DAYS. INCREASE FREQUENCY FOR MORE SEVERE ENVIRONMENTS.



ONLY TRAINED AND QUALIFIED PERSONNEL SHALL PERFORM INSPECTION OR MAINTENANCE AND SERVICE PROCEDURES.



Arc flash and shock hazard PPE (personal protection equipment) required. De-energize equipment before working on or inside. Do not open cover without appropriate PPE. Refer to NFPA 70E for PPE requirements. This panel may contain more than one power source. Hazardous voltage will cause severe injury or death.



NEVER GO BENEATH THE LIFT TABLE FOR ANY REASON UNLESS IT IS PROPERLY SUPPORTED (SEE HOW TO SUPPORT THE LIFT TABLE DURING INSPECTION AND OR ROUTINE MAINTENANCE, page 12). BARRICADE ALL AREAS FROM TRAFFIC AROUND THE WORK AREA INSIDE (AND OUTSIDE IF APPLICABLE) FOR SAFETY AND POST APPROPRIATE WARNING SIGNS. THE POWER IS DISCONNECTED WITH A FUSED DISCONNECT, PROPERLY TAGGED AND LOCKED OUT. FUSED DISCONNECT AND LOCKOUT DEVICE (SUPPLIED AND INSTALLED BY OTHERS) MUST MEET WITH ALL APPLICABLE CODES AND REGULATIONS. ALL ELECTRICAL WORK MUST BE PERFORMED BY A QUALIFIED ELECTRICIAN IN ACCORDANCE WITH ALL APPLICABLE CODES AND REGULATIONS. IT IS THE RESPONSIBILITY OF THE OWNER TO ENSURE THAT NO LOAD EXISTS ON THE PLATFORM WHILE THE MAINTENANCE STAND IS ENGAGED. THE CONSTRUCTION OF THE MAINTENANCE STAND IS INTENDED TO SUPPORT THE WEIGHT OF THE UNLOADED LIFT TABLE ONLY.



THE RELIEF VALVE ON THE POWER UNIT IS PRESET AT THE FACTORY. IT IS AN IMPORTANT SAFETY DEVICE. DO NOT ADJUST OR REMOVE THE RELIEF VALVE.



BE SURE ALL HYDRAULIC FITTINGS ARE RATED FOR HYDRAULIC SYSTEMS THAT MAY PEAK OUT AT 4000PSI. HARDWARE STORE ITEMS CAN BURST AT 150PSI. ONLY BUY REPLACEMENT PARTS FROM PENTALIFT.

**NOTE:** Read the SAFETY INFORMATION AND WARNINGS before servicing the lift table. (See page page II.)

**NOTE:** It is the owner's responsibility to assure that all labeling remains legible and in its original position throughout the life of the product. (See Safety Labeling Section, page 2)

**NOTE:** Inspect equipment for protective coatings (i.e. paint) that have deteriorated or been removed. Prepare affected area and reapply protective coating as required using Tremclad High Performance Rust Enamel (Gloss Dark Machine Grey).

**NOTE:** At every maintenance interval, inspect the lift table for any damaged or worn parts. If any damaged or worn parts are found, discontinue use of the lift table and/or repair immediately.



Be sure the maintenance stand is properly engaged before performing maintenance checks 2 through 6 or reaching beneath a raised lift. (See "HOW TO SUPPORT THE LIFT TABLE DURING INSPECTION AND OR ROUTINE MAINTENANCE" on page 12).

1. Clean all debris from the pit or the vicinity of floor mounted units in order to avoid interference with the lift mechanism or rollers.
2. Check for presence and proper seating of all spring pins on all axles, cylinders and rollers. Confirm that all welds on the spring pin collars are intact. (See "Figure 7: Spring Pins" on page 15)
3. Check rollers, pins and bushings for any signs of wear such as flat spots, missing fasteners, or dislodged bearing material.
4. Check the hydraulic fittings for cracks or leaks and clean up any seepage on or beneath the cylinders.

5. Check hoses and electrical lines for abrasions or other abuse and check for snug connections.
6. Operate the unit and check for any abnormal noise or vibrations.
7. Check all safety devices on the unit including any options such as toe sensors and hydraulic bridges, for proper operation.
8. Check the hinged bridge to insure that its stops are not damaged, allowing it to droop more than 45 degrees below horizontal, check the hinge spools for cracks and or broken welds.

### Hydraulic Oil:

**Weekly:** Once a week, or after repetitive operation, the lift should be raised to its full height. This will get rid of cylinder oil seepage build-up and lubricate the upper cylinder barrel.

**Monthly:** Lift tables do not require lubrication of the pivot points. For ease of maintenance, lifetime lubricated bushings have been used on all rollers, leg pivot points as well as the upper cylinder pivot. However, units installed outdoors or in wet and dirty environments should be lubricated. The recommended lubrication **service interval is every 30 days** or at a greater frequency as required in severe environments. **Dexron Automatic Transmission Fluid** is recommended.

**NOTE:** If the equipment was purchased with the optional high cycle package, bearings that do require lubrication are utilized in the equipment. Make sure that lubrication with the appropriate grease is completed on a bi-weekly basis.

The oil level should be checked once a month. When the lift table is fully lowered, the oil level in the reservoir of a 1 or 3 hp power unit should be approximately 2 – 3 inches from the top. A 5 hp or higher power unit should have the oil in the reservoir filled to the full mark on the sight gauge. The oil should be changed once a year under normal operating conditions. It is strongly urged that a maintenance log be maintained with the dates of monthly inspections, the name of the inspector and results of the inspection.

**Seasonal or semiannual maintenance:** Change hydraulic fluid for ambient temperature changes if appropriate. Check the fluid reservoir to see if there is any evidence of accumulated condensation creating water contamination. The fluid will appear “milky” and light pink in color. Water accumulation will damage the hydraulic pump.

**NOTICE** The standard hydraulic oil supplied with the equipment is good from +10° C (+50°F) minimum to +50°C (+122°F) maximum unless otherwise specified on the equipment order. When operating the equipment in temperatures lower than +10°C (+50°F) or above +50°C (+122°F), the pump may create cavitation, causing permanent damage to the power unit. This will void all warranty. The standard replacement Hydraulic Fluid is DEXRON III Automatic Transmission Fluid which has an operating range of -10°C (14°F) to 50°C (122°F). If the hydraulic oil is non-standard, check the hydraulic reservoir for fluid label which will specify the particular oil requirements.

Ensure the toe sensor (if equipped) is functional by raising the lift to full height and lifting the toe sensor bar under each of the toe sensor limit switches (there are normally 4 switches). Confirm the unit does not lower with the toe sensor bar raised. Repeat the lifting on each of the limit switches and confirm the unit will not lower when the bar is lifted under any of the switches. **NOTE:** The toe sensor option is an electrical safety device with an actuator suspended beneath the platform which halts downward travel of the lift table if it contacts with an obstruction. (This feature is not functional in the event of hydraulic failure.)

Check all spring pins, items 4, 5 & 12 on “Figure 10: Lift Table Parts” on page 20, to confirm they are not damaged and that they are properly inserted.

**Note:** If lift table is equipped with the optional high cycle package, refer to “High Cycle Addendum” for Maintenance and Lubrication and Replacement Parts.

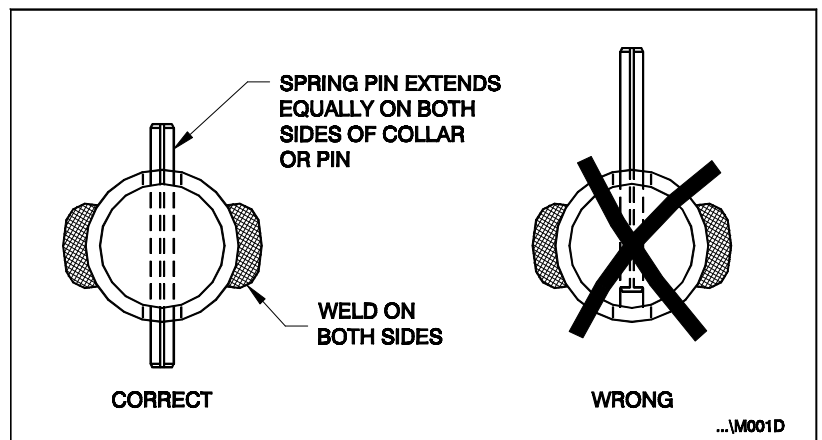

Figure 7: Spring Pins

# TROUBLE SHOOTING GUIDE

**NOTE:** This equipment has been fully tested and confirmed to be operational at the factory. Historically, the majority of operating problems are caused by unnecessary tampering by unqualified personnel. To conform to the terms of the Warranty, contact your authorized Pentalift representative if you are having any difficulty with the lift table during the warranty period. Do not risk voiding the warranty by tampering with the equipment.



**ONLY TRAINED AND QUALIFIED PERSONNEL SHALL PERFORM INSPECTION OR MAINTENANCE AND SERVICE PROCEDURES.**



**Before doing any installation, maintenance, inspection or trouble shooting, barricade all areas from traffic around the work area inside (and outside if applicable) for safety and post appropriate warning signs.**



**Arc flash and shock hazard PPE (personal protection equipment) required. De-energize equipment before working on or inside. Do not open cover without appropriate PPE. Refer to NFPA 70E for PPE requirements. This panel may contain more than one power source. Hazardous voltage will cause severe injury or death.**



**Before doing any electrical work, be certain that the power is disconnected with a fused disconnect, properly tagged and locked out. Fused disconnect and lockout device (supplied and installed by others) must meet with all applicable codes and regulations. All electrical work must be performed by a qualified electrician in accordance with all applicable codes and regulations.**



**NEVER GO BENEATH THE PLATFORM UNLESS THE LOAD IS REMOVED AND THE SCISSOR MECHANISM IS PROPERLY BLOCKED (SEE page 12.)**



**THE RELIEF VALVE ON THE POWER UNIT IS PRESET AT THE FACTORY. IT IS AN IMPORTANT SAFETY DEVICE. DO NOT ADJUST OR REMOVE THE RELIEF VALVE.**

## **NOTICE**

See page 14 for recommended hydraulic oil.

### **1. Lift table will not rise when the push button is depressed.**

- Confirm that power is reaching power unit.
- Re-check all wiring and hydraulic connections. Refer to the wiring diagram found inside the motor control panel.
- Ensure proper hydraulic fluid level. (See page 14.)
- Examine all moving parts for obstructions.
- On 3 phase units assure phase rotation is correct. Incorrect rotation will cause the lift table not to lift. The motor will run backwards resulting in cavitation and possible damage to the pump.
- If the problem cannot be solved, consult your authorized Pentalift representative.

### **2. Motor runs, however, the lift table does not rise.**

- Ensure proper hydraulic fluid level. (See page 14.)
- On 3 phase units assure phase rotation is correct. Incorrect rotation will cause the lift table not to lift. The motor will run backwards resulting in cavitation and possible damage to the pump. Reversing the 2 power leads will correct this issue.
- Check for any obstructions.
- Check to ensure load does not exceed rated capacity of lift table.
- If the problem cannot be solved, consult your authorized Pentalift representative.

### **3. Breaker is disengaging.**

- Ensure proper voltage is reaching the motor. (See ELECTRICAL REFERENCE - 1 ½ HP chart, page 9.)
- Check for any obstructions.
- Check all wiring connections.
- If the problem cannot be solved, consult your authorized Pentalift representative.

**4. Lift table rises or lowers with a jerking movement.**

- a) Ensure proper hydraulic fluid level. (See page 14.)
- b) Air may be present in the hydraulic system. (See initial set-up; item 17, page 8.)
- c) Check for any obstructions.
- d) Check to ensure load does not exceed rated capacity of lift table.
- e) Ensure lift table is shimmed properly. (See "INSTALLATION INSTRUCTIONS" on page 5.)
- f) If the problem cannot be solved, consult your authorized Pentalift representative.

**5. Lift table will not lower.**

- a) Re check all wiring.
- b) Check for any obstructions.
- c) Ensure lowering valve is energized when down button is depressed.
- d) If equipped with optional toe sensors, ensure toe sensors are not engaged. (I.e. obstruction under toe sensors, etc. See Maintenance & Lubrication section, page 14, for a definition of toe sensors.)
- e) If the problem cannot be solved, consult your authorized Pentalift representative.

If damaged or worn parts are detected upon inspection, replacement must be undertaken **immediately**. **The lift table must not be used until replacement is completed.** Parts are readily available from your Pentalift representative.

Generic manual for reference only. Contact Pentalift with product serial number to receive owners manual for your specific equipment.

## REPLACEMENT PARTS

USE ONLY GENUINE PENTALIFT REPLACEMENT PARTS



To ensure proper functioning, durability and safety of the product, only genuine pentalift replacement parts must be used. Altering the product from its original manufactured configuration must not be done. Pentlift equipment Corporation disclaims all liability for failure to comply with this warning. Warranties are specifically disclaimed in the event the purchaser fails to comply with this warning.

To expedite order processing when ordering parts, provide the following information to your Pentlift representative:

1. Model and Serial Number of equipment.
2. Part Number, Description and Quantity.
3. Shipping Instructions.

## LIFT CYLINDER PARTS

USE ONLY GENUINE PENTALIFT REPLACEMENT PARTS

<u>Item #</u>	<u>Description</u>	<u>3 1/2" D Piston 4" OD Housing</u>	<u>4" D Piston 4 1/2" OD Housing</u>
1	Seal Kit (*included in Seal Kit) Not Shown	800-0284	800-0316
2	Velocity Fuse	NOTE	NOTE
3	90° Fitting (1 Cylinder, with Fuse)	052-0065	052-0065
4	Cylinder Barrel	NOTE	NOTE
5	*Set Screw	072-0119	072-0119
6	*By-Pass Comp. Spring	097-0020	097-0020
7	*By-Pass Steel Ball	090-0001	090-0001
8	*By-Pass Cartridge Pin	300-4001	300-4001
9	*Piston U Cup	054-0501	054-0502
10	Piston By-Pass Cartridge	300-0883	300-0888
11	*Wear Ring	054-0521	054-0522
12	*Dump Tube Nut	070-0060	070-0060
13	*Dump Tube Bolt	072-0044	072-0044
14	End Pivot Tube Bushing	095-0015	095-0015
15	Piston Rod	NOTE	NOTE
16	*Piston Wiper	054-0504	054-0504
17	*Inner "O" Ring	054-0329	054-0329
18	*Retaining Ring	300-0088	300-0203
19	*Outer "O" Ring	054-0338	054-0342
20	Head Nut	300-0000	300-0001
21	Dump Tube	300-6145	300-6145
22	90° Fitting (1 Cylinder, without Fuse)	052-0052	052-0052
23	Flow Control	NOTE	NOTE
24	90° Fitting (1 Cylinder, without Fuse)	052-0083	052-0083
25	Adapter (2 Cylinders)	052-0048	052-0048
26	Tee Fitting (2 Cylinders)	052-0039	052-0039
27	0° Fitting (2 Cylinders, without Fuse)	052-0028	052-0028
28	Adapter (2 Cylinders, with Fuse)	052-0023	052-0023

**NOTE:** State Model # and Serial # when ordering replacement parts.

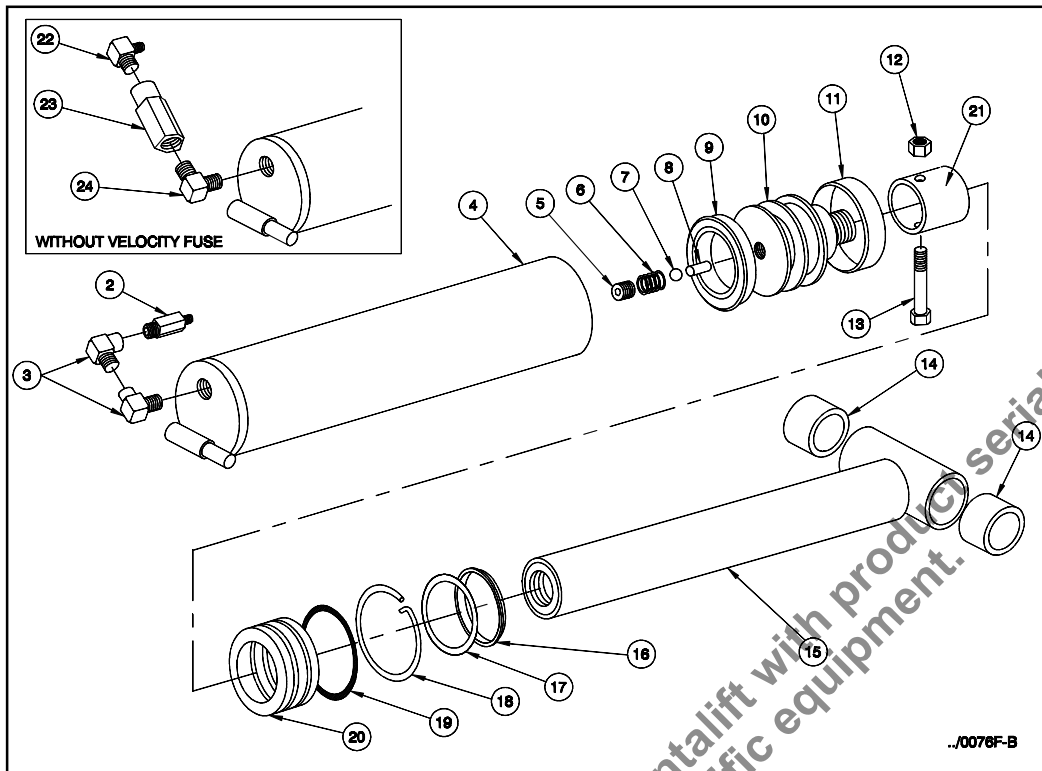

Figure 8: Single Cylinder Models

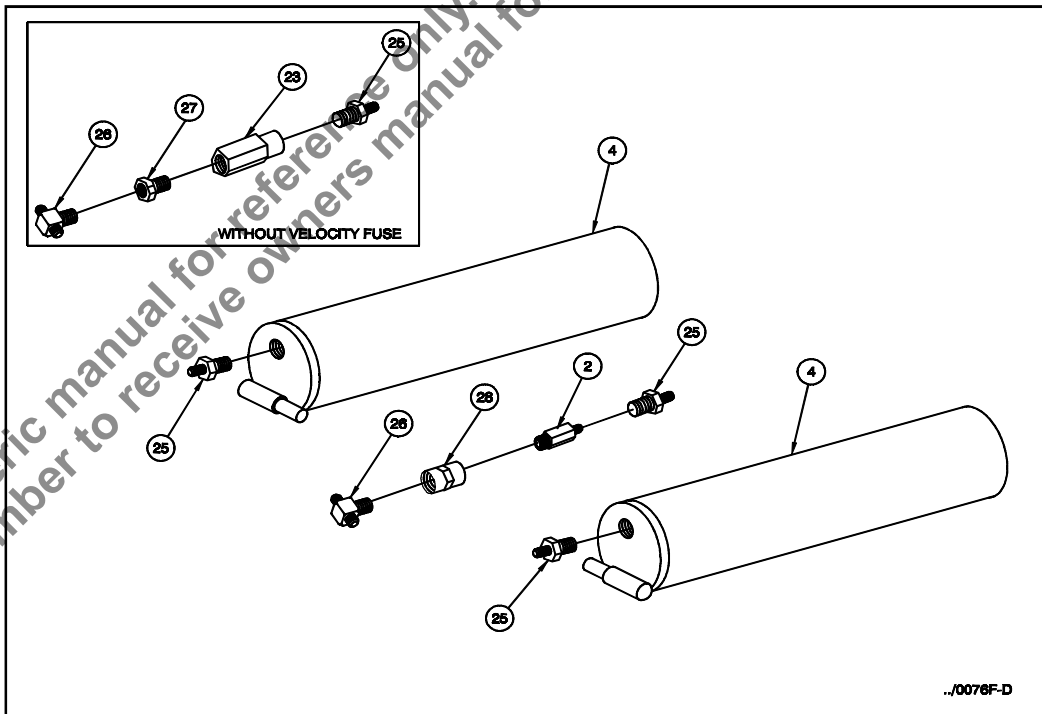

Figure 9: Dual Cylinder

# LIFT TABLE PARTS

USE ONLY GENUINE PENTALIFT REPLACEMENT PARTS

Item #	Part No.	Description
1	800-6223	Roller Assembly
2	-----	Cylinder Assembly (See Page 19)
3	300-6453	Cylinder Pin 1 1/4" Dia. Single Cylinder
	300-6452	Cylinder Pin 1 1/4" Dia. Dual Cylinder
4	080-0024	Spring Pin
5	080-0017	Spring Pin
6	300-6069	Fixed End Pivot Pin
7	NOTE	Single Cylinder Pressure Line
8	NOTE	Single Cylinder Return Line
9	NOTE	Dual Cylinder Power Unit Pressure Line
10	NOTE	Dual Cylinder Power Unit Return Line
11	800-6234	Dual Cylinder Pressure Line
12	800-6235	Dual Cylinder Return Line
13	060-0079	Optional Toe sensor Limit Switch (Not Shown)
14	080-0025	Spring Pin

**NOTE:** State Model # and Serial # when ordering replacement parts.

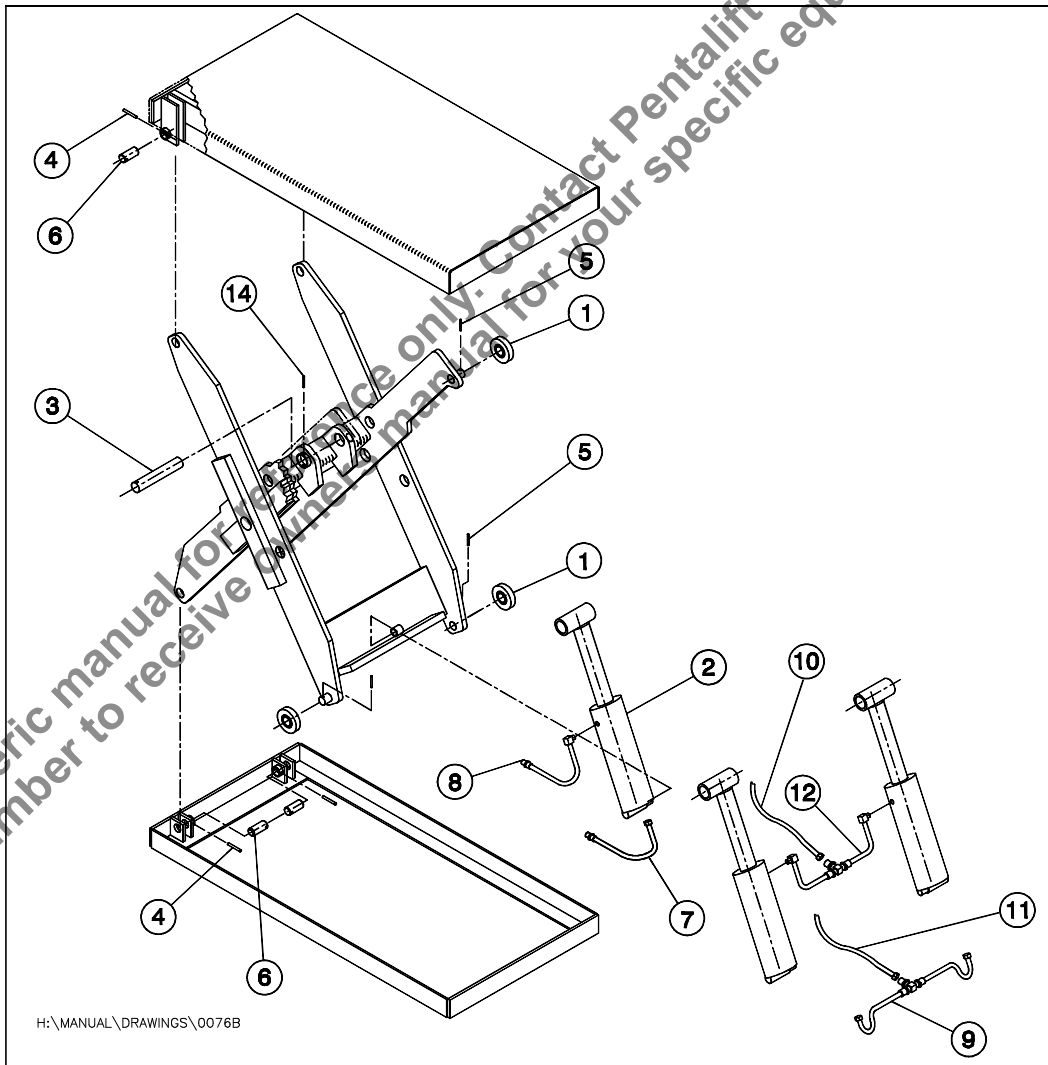
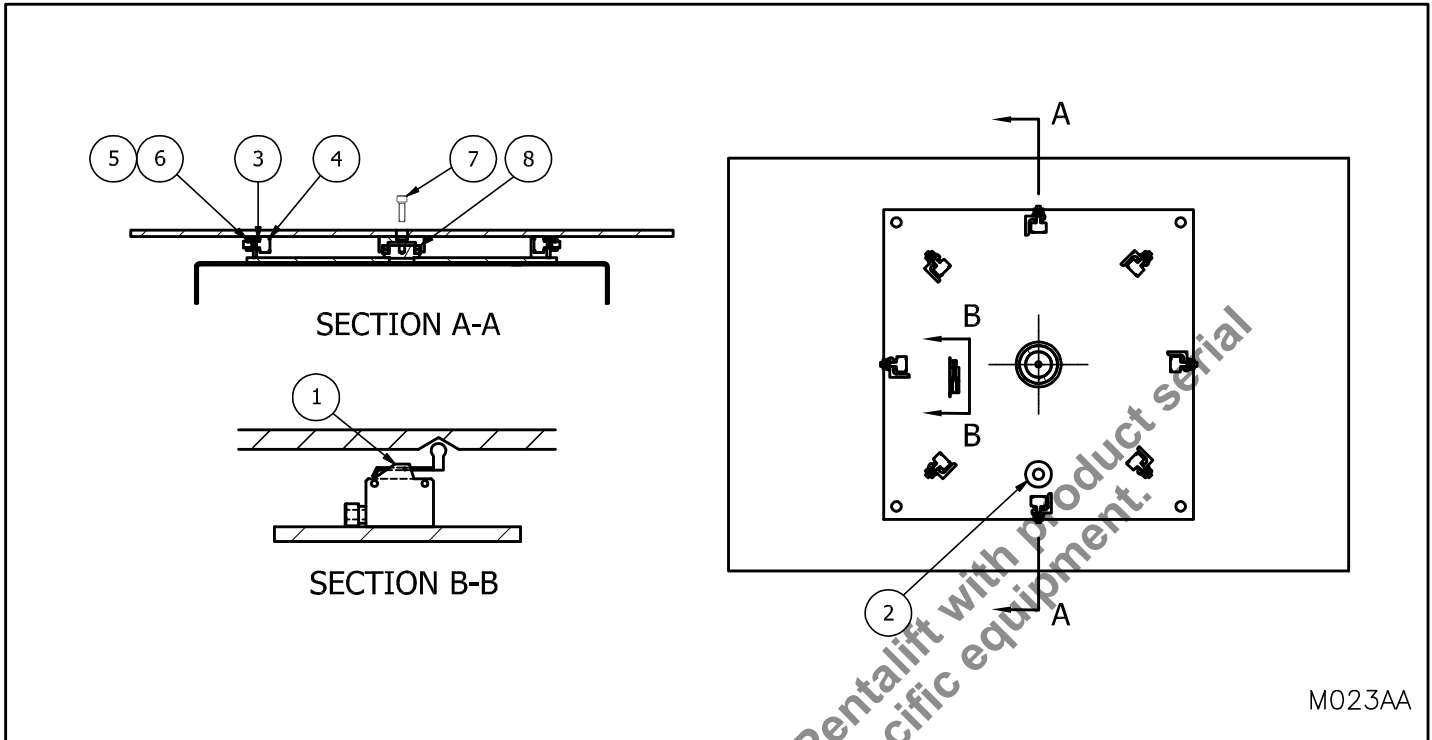

Figure 10: Lift Table Parts

# ROTATING TOP

USE ONLY GENUINE PENTALIFT REPLACEMENT PARTS



M023AA

**Figure 11: Rotating Top Replacement Parts**

<u>Item</u>	<u>Part No.</u>	<u>Description</u>
1	060-0052	Home Position Limit Switch (Optional)
2	090-0016	Detent
3	311-0020	Spacer
4	090-0050	Cam Follower
5	074-0077	1/2" Helical Spring Lock Washer
6	0700006	Hex Nut
7	072-0121	Thrust Bolt
8	090-0015	Thrust Bearing

**NOTE:** Always place loads in the center of the rotator and never exceed the rated capacity as shown on the specification plate. (See "Figure 2: Safety Label and Decal Locations" on page 3.)

**NOTE:** State Model # and Serial # when ordering replacement parts.

# DUAL FOOT PEDAL CONTROL

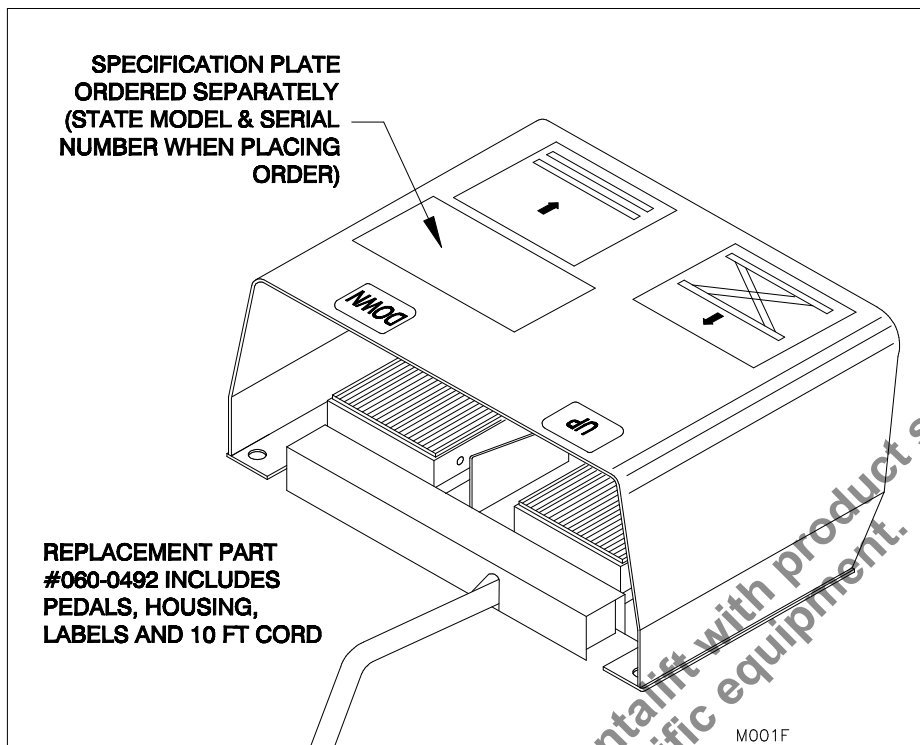

Figure 12: Foot Pedal Replacement Parts

# LIMIT SWITCH

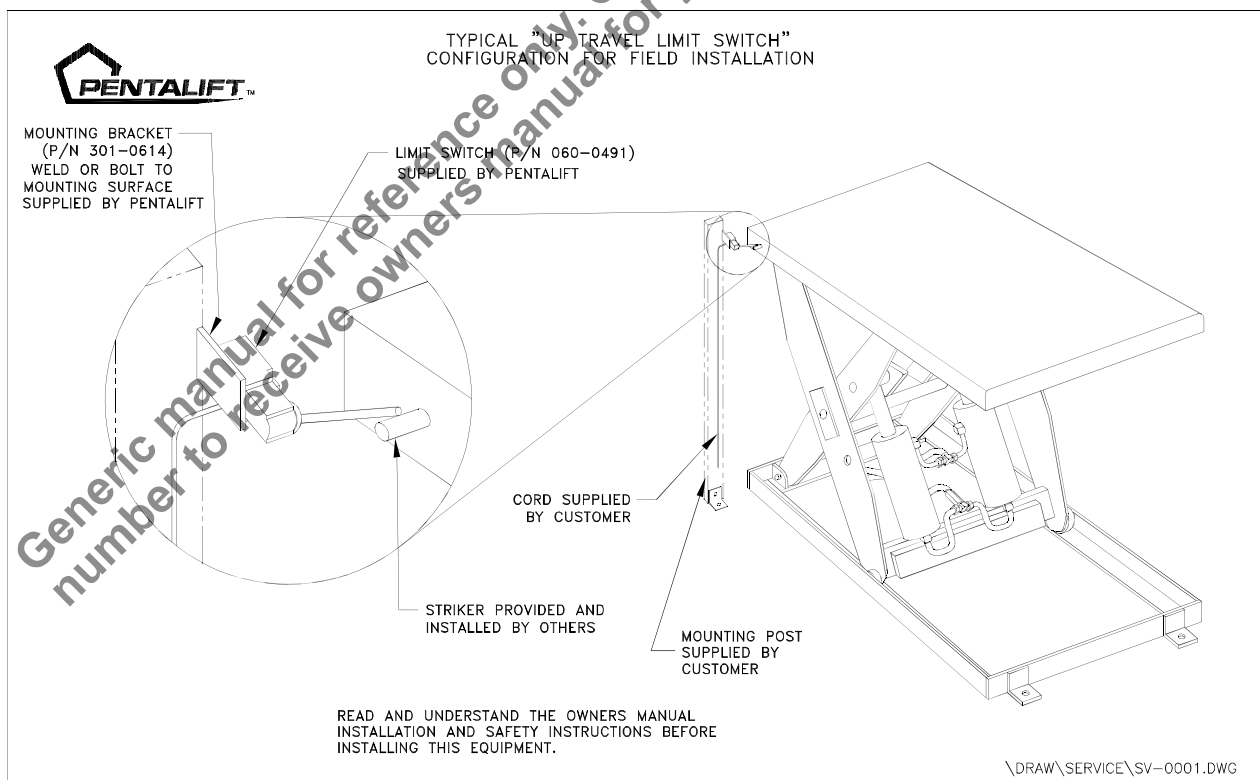

Figure 13: Field Installation of Limit Switch

# CONTROL BOX DRAWINGS

NOTE: FOR REFERENCE ONLY- Control Boxes may not be exactly as illustrated

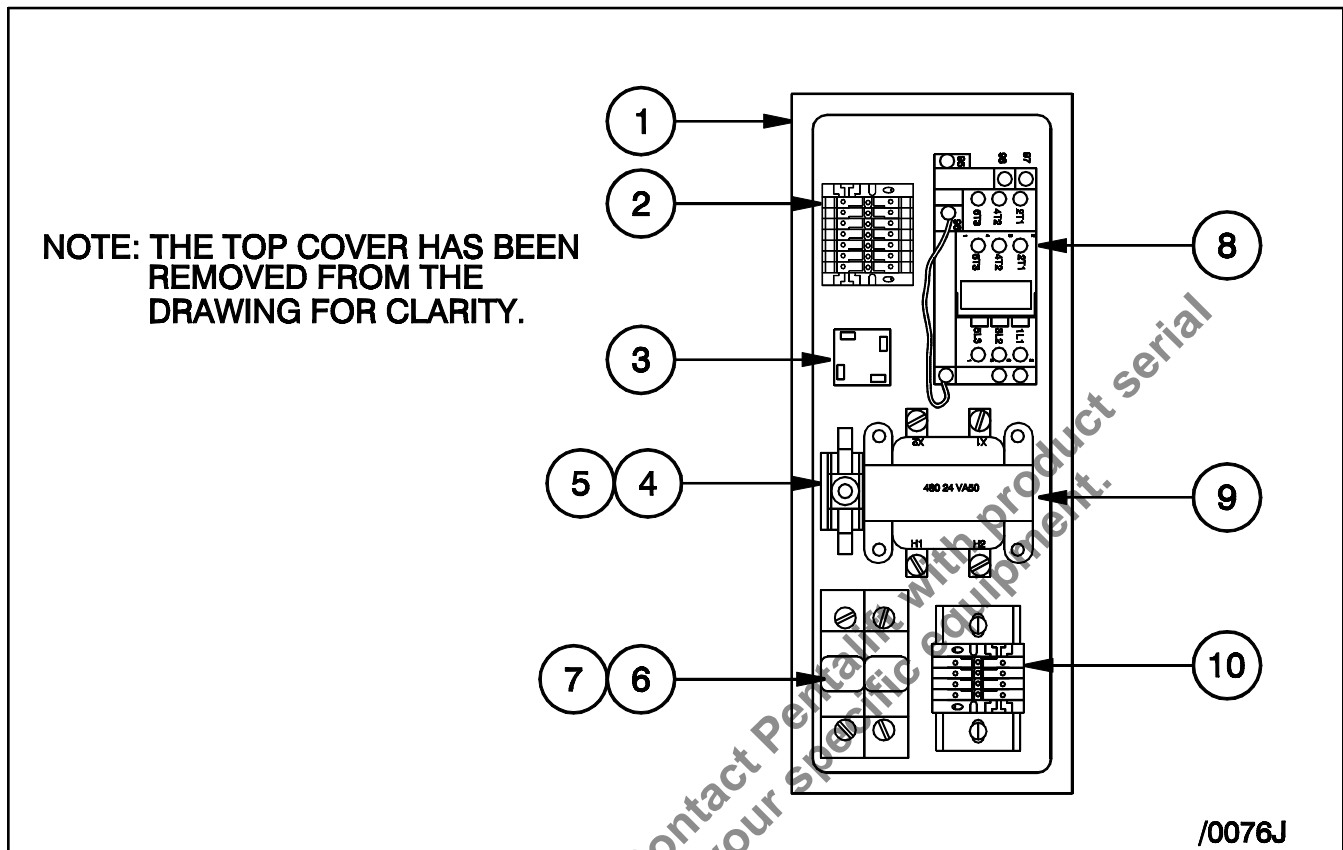

Figure 14: 3 Phase Self-Contained Power Unit

<u>Item</u>	<u>Part No.</u>	<u>Qty/Unit</u>	<u>Description</u>
1	060-0297	1	Enclosure
2	060-0294	1	Terminal
3	060-0071	1	Bridge Rectifier
4	060-0023	1	Fuse Holder
5	NOTE	1	Fuse
6	060-0230	1	Fuse Holder
7	NOTE	2	Fuse
8	NOTE	1	Motor Starter
9	NOTE	1	Transformer
10	060-0294	1	Terminal

**NOTE:** State Model # and Serial # when ordering replacement parts.

## CONTROL BOX DRAWINGS (CON'T)

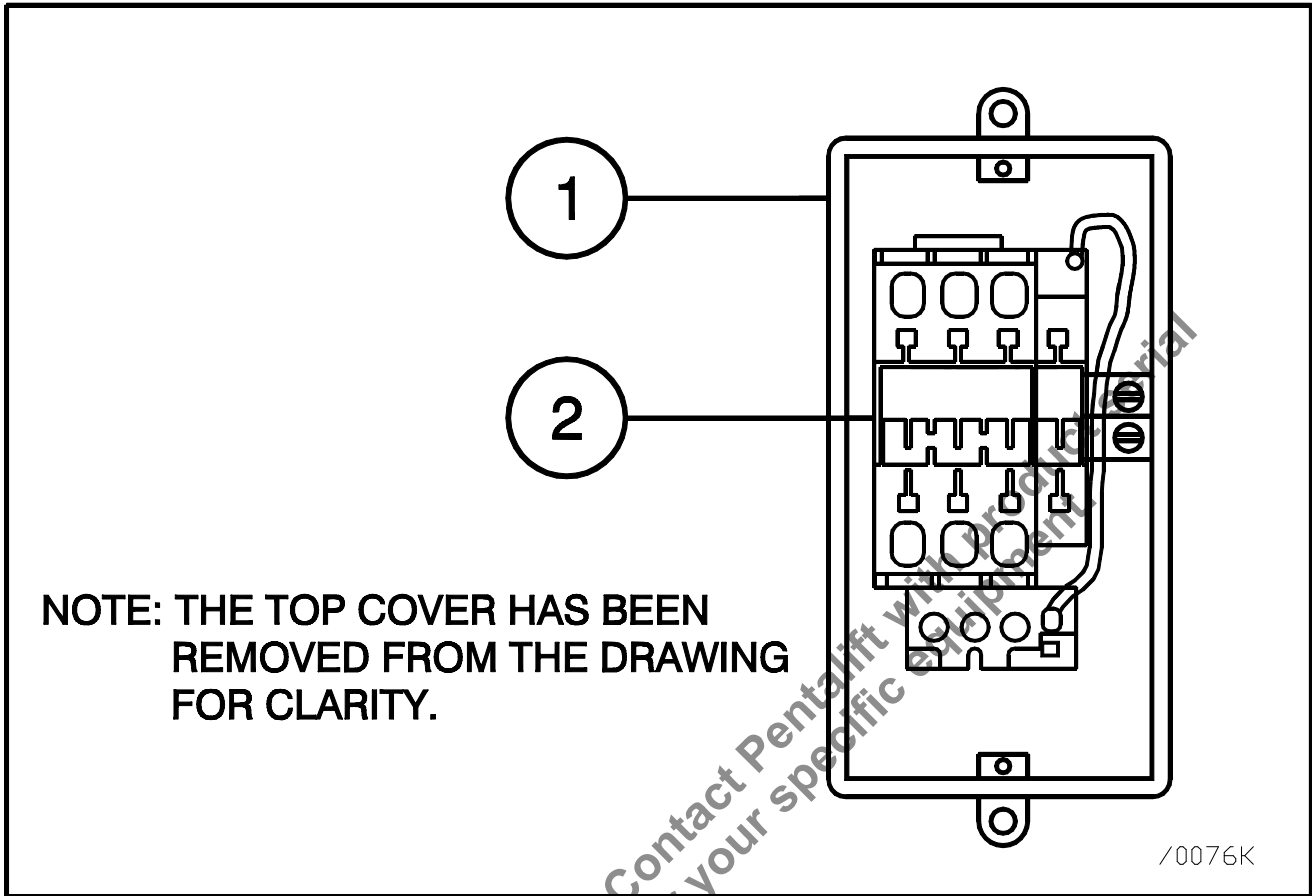

Figure 15: 1 Phase Self-Contained & Remote Power Unit

<u>Item</u>	<u>Part No.</u>	<u>Qty/Unit</u>	<u>Description</u>
1	060-0268	1	Enclosure
2	NOTE	1	Motor Starter

**NOTE:** State Model # and Serial # when ordering replacement parts.

# CONTROL BOX DRAWINGS (CON'T)

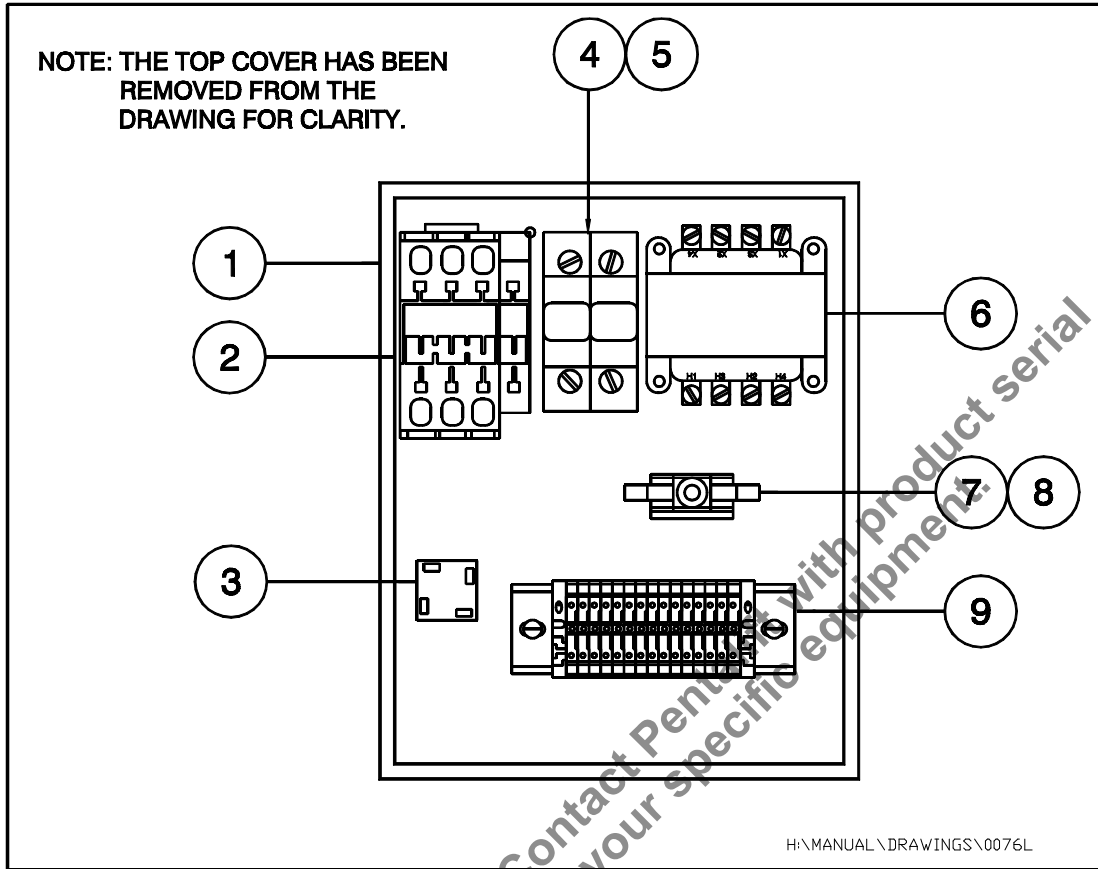

Figure 16: 3 Phase Remote Power Unit & 1 Phase Remote Power Unit c/w Toe Sensors

<u>Item</u>	<u>Part No.</u>	<u>Qty/Unit</u>	<u>Description</u>
1	060-0004	1	Enclosure
2	NOTE	1	Motor Starter
3	060-0071	1	Bridge Rectifier
4	060-0230	1	Fuse Holder
5	NOTE	2	Fuse
6	060-0302	1	Transformer
7	060-0023	1	Fuse Holder
8	NOTE	1	Fuse
9	060-0294	1	Terminal

**NOTE:** State Model # and Serial # when ordering replacement parts.

# LIST OF ILLUSTRATIONS

Figure 1: Safety Labels and Decals .....	2
Figure 2: Safety Label and Decal Locations .....	3
Figure 3: Platform Safety Features .....	7
Figure 4: Shim Positions .....	8
Figure 5: How to Support the Lift Table .....	12
Figure 6: Optional Lift Table Supporting .....	12
Figure 7: Spring Pins .....	15
Figure 8: Single Cylinder Models .....	19
Figure 9: Dual Cylinder .....	19
Figure 10: Lift Table Parts .....	20
Figure 11: Rotating Top Replacement Parts .....	21
Figure 12: Foot Pedal Replacement Parts .....	22
Figure 13: Field Installation of Limit Switch .....	22
Figure 14: 3 Phase Self-Contained Power Unit .....	23
Figure 15: 1 Phase Self-Contained & Remote Power Unit .....	24
Figure 16: 3 Phase Remote Power Unit & 1 Phase Remote Power Unit c/w Toe Sensors .....	25

Generic manual for reference only. Contact Pentalift with product serial number to receive owners manual for your specific equipment.

# PENTALIFT EQUIPMENT CORPORATION WARRANTY

## WARRANTY

**Pentalift Equipment Corporation** expressly warrants that any product manufactured by **Pentalift Equipment Corporation** will be free from defects in material and workmanship under normal use for a period of one (1) year from the date of shipment of the equipment, provided the original purchaser maintains and operates the product in accordance with proper procedures. In the event the product proves defective in material or workmanship, **Pentalift Equipment Corporation** will at its option:

1. Replace the product or the defective portion thereof without change to the purchaser; or
2. Alter or repair the product; on site or elsewhere, as **Pentalift Equipment Corporation** may deem advisable, without charge to the purchaser.

The warranty stated in the previous paragraph is that expressed by **PENTALIFT EQUIPMENT CORPORATION** AND IS IN LIEU OF ALL GUARANTEES AND WARRANTIES, EXPRESSED OR IMPLIED BY ANYONE OTHER THAN **PENTALIFT EQUIPMENT CORPORATION**. This warranty does not cover any failure caused by improper installation, misapplication, overloading, abuse, negligence, or failure to lubricate and adjust or maintain the equipment properly and regularly. Parts requiring replacement due to damage resulting from abuse, improper operations, improper or insufficient lubrication, lack of proper protection or vehicle impact are not covered by this warranty. **Pentalift Equipment Corporation** assumes no responsibility or liability for:

1. Consequential damages of any kind which result from use or misuse of the equipment.
2. Damage or failure resulting from the use of unauthorized replacement parts.
3. Damage or failure resulting from modification of the equipment.
4. Damage resulting from the misuse of the equipment.

THERE ARE NO WARRANTIES, EXPRESSED OR IMPLIED, WHICH EXTEND BEYOND THE DESCRIPTION ON THE FACE HEREOF, AND THERE IS NO WARRANTY OF MERCHANTABILITY OR OF FITNESS FOR A PARTICULAR PURPOSE.

**Pentalift Equipment Corporation** warranties extend only to the original product itself. In no event shall **Pentalift Equipment Corporation** be responsible for or liable to anyone, including third parties, for special, indirect, collateral, punitive, incidental or consequential damages, even if **Pentalift Equipment Corporation** has been advised of the possibility of such damages. Such excluded damages include, but are not limited to, loss of good will, loss of profits, loss of use, interruption of business or other similar indirect financial loss.

**Pentalift Equipment Corporation** DISCLAIMS all liability arising out of the workmanship, methods and materials used by the installer.

**Pentalift Equipment Corporation** DISCLAIMS all liability for premature product wear, product failure, property damage or bodily injury arising from improper installation and application.

**Pentalift Equipment Corporation** will not accept any warranty for which the original purchaser does not notify **Pentalift Equipment Corporation's** Warranty Department of the defect within ninety (90) days after the product defect is discovered. A fully completed Product Registration Card is required prior to the review or processing of any warranty requests or claims.

WARRANTIES, whether expressed or implied, relating to workmanship and materials used in connection with the installation of **Pentalift Equipment Corporation** products are specifically DISCLAIMED.

WR001R02



P.O. Box 1510, Buffalo, NY, U.S.A. 14240-1510  
Phone: (519) 763-3625 □ FAX (519) 763-2894  
21 Nicholas Beaver Rd, Puslinch, Ontario, N0B 2J0 Canada  
Phone: (519) 763-3625 □ FAX (519) 763-2894

**NOTE:** All Pentalift Equipment Corporation products are subject to design improvement through modification without notice.