



Pentalift Dock Lifts

Model HED Pit Mounted Dock Lifts



The ultimate in versatility and reliability for shipping and receiving operations

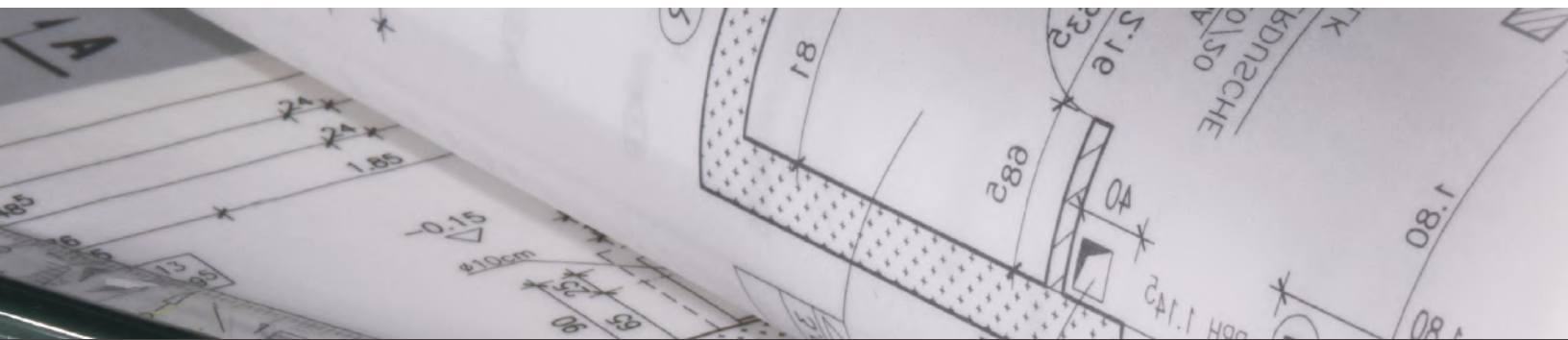

Engineered for Safety

Pentalift: The best choice for Dock Lifts

Since 1983 Pentalift has grown to be recognized as one of North America's premier manufacturers of loading dock and dock lift equipment. In addition to loading dock equipment, Pentalift manufactures custom scissor lifts. Some examples of these custom lifts are shown on this page. The continuing success in designing, engineering, and manufacturing custom lifts and superior loading dock solutions make Pentalift the best possible choice for your dock lift requirements.



Shown below are some examples of Pentalift's application design engineering and manufacturing capabilities.



Application designed lift. One of the world's premier jet aircraft engine manufacturers commissioned a mobile test station. During the certification process the engine must be tested and inspected on an ongoing basis. The Pentalift lift table, installed on an industrial truck chassis, is driven to and positioned under the aircraft engine. The technicians are then raised to a safe working height to perform the assigned tasks. The lift has a platform size of 16' x 24', raises 15' and has a lifting capacity of 16,000 lbs.



This application designed double scissor dock lift accomplishes significant additional travel without increasing the length of the frame.

Pentalift Dock Lift Installation Arrangements

Shown below are concept depictions of a variety of common installation arrangements for dock lifts. Pentalift has extensive experience in designing, manufacturing and applying dock lifts for the widest variety of applications. Careful consideration, knowledge and experience are imperative when designing an efficient and safe loading dock. Pentalift is your best choice in achieving this objective. Contact your Pentalift representative for additional information on installation arrangements.

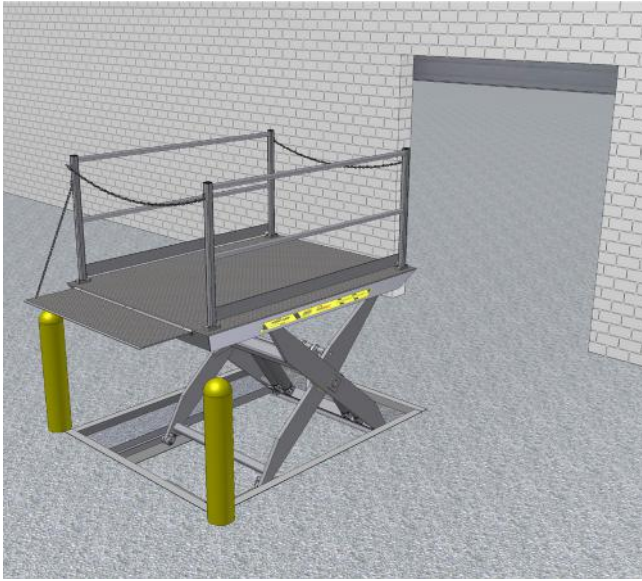

(A) Exterior grade level recessed pit installation

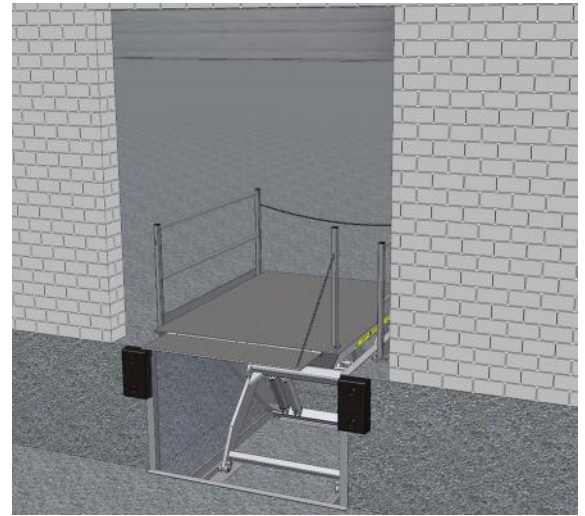

(B) Interior grade level to higher dock level full pit installation (pit mount)

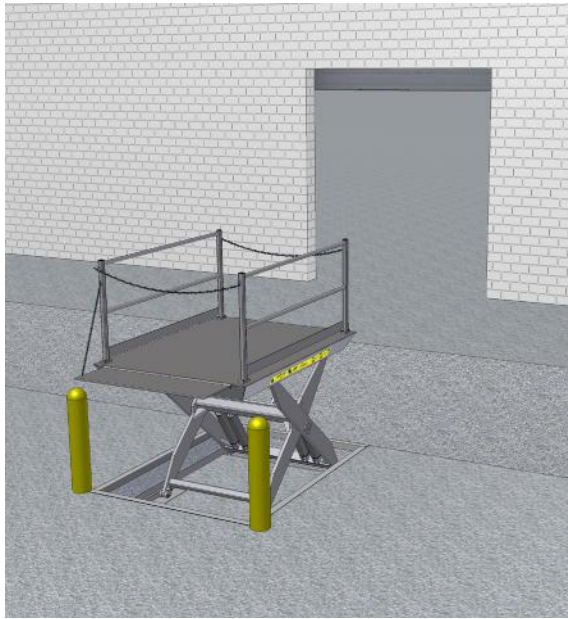

(C) Exterior grade level to dock level recessed pit installation (front mount)



(D) Exterior grade level to lower dock level full pit installation (pit mount)

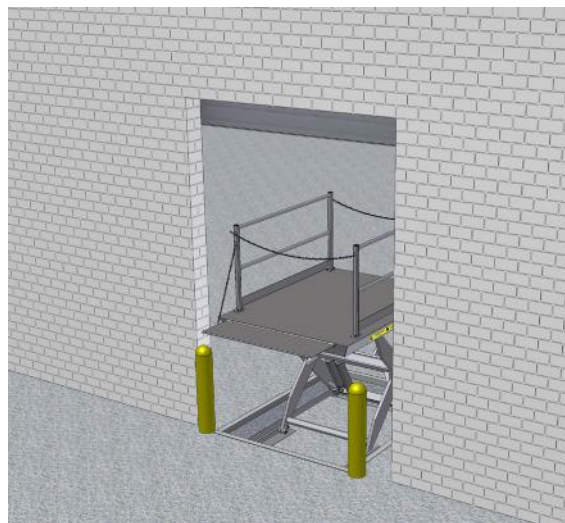

(E) Interior grade and floor level recessed pit installation

Pentalift HED 12 Inch Low Height Dock Lift Design Features

The Pentalift HED dock lift, is a pit mounted dock lift designed for increasing efficiency and safety in loading / unloading trucks and trailers. The design and features of the Pentalift HED make it the highest quality dock lift available. The HED dock lift is the best possible choice for a large number of loading dock applications.

OSHA compliant 42" high removable steel guard rail c/w mid rail and 4" kick plate.

Plated access chain: Prevents operator from falling.

High tensile steel checker plate hinged bridge and platform with structural supports.

Bevel toe guards for pit mounting protection.

Scissor legs: Solid steel one piece construction with precision reamed holes. All pivot pins are chrome plated.

Exclusive PentaFLOW hydraulic bypass cylinder (see opposite page) with hydraulic velocity fuse.

Hinged integral maintenance stand.

Shipped complete: Finished product, power unit, controls (standard push button control shown) and all other components are factory load-tested and shipped fully assembled, complete with hydraulic fluid.

"Lubricated for life" maintenance free bearings at all pivot points.



Exclusive Pentalift

PentaFLOW

Hydraulic Cylinder

The lift cylinder is the heart on any hydraulic lift system, Pentalift's exclusive design ensures the longest cylinder life, reduces maintenance and eliminates oil spills.

Here's How it works:

Pentalift's PentaFLOW cylinder is completely sealed from the surrounding atmosphere and all components are continuously bathed in fresh oil. Contamination and deterioration of the cylinder cannot occur. When the cylinder reaches full extension, the bypass valve opens and allows oil to flow through the piston to the rod side of the cylinder, out the port, and back to the reservoir. This prevents the cylinder from dead ending and building high stresses in the cylinder, equipment structure and hydraulic system. Air in the cylinder is automatically removed through the bypass valve eliminating the need for manual bleeding which often results in oil spills and contamination.

Note: Precision turned, ground, polished and chrome plated cylinder rod and "drawn over mandrel" precision honed barrels are standard on all PentaFLOW cylinders.

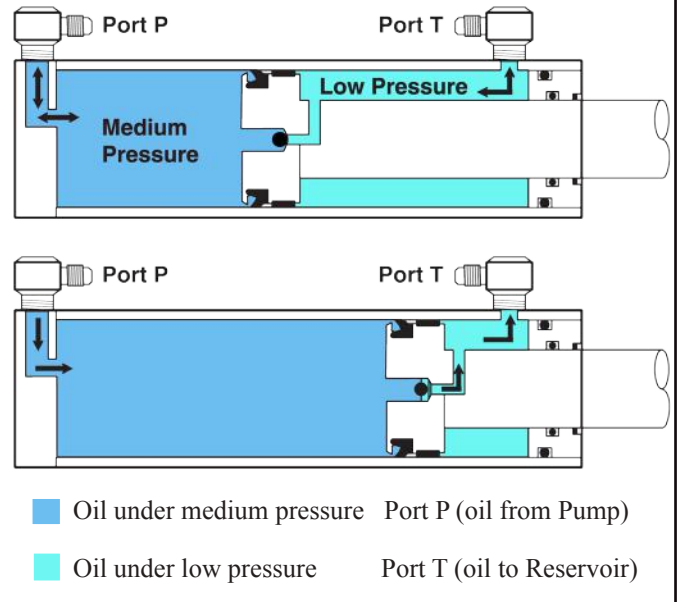

Pentalift HED Dock Lift Models: The following models and sizes are available

MODEL NUMBER	PLATFORM SIZE (wide x long)	VERTICAL LIFT (inches)	CAPACITY RANGE (lb)
HED 47_	48" x 84"	50"	3,000 – 15,000 lb
HED 48_	48" x 96"	59"	3,000 – 20,000 lb
HED 49_	48" x 108"	59"	3,000 – 20,000 lb
HED 410_	48" x 120"	59"	3,000 – 20,000 lb
HED 57_	60" x 84"	50"	3,000 – 15,000 lb
HED 58_	60" x 96"	59"	3,000 – 20,000 lb
HED 59_	60" x 108"	59"	3,000 – 20,000 lb
HED 510_	60" x 120"	59"	3,000 – 20,000 lb
HED 67_	72" x 84"	50"	3,000 – 15,000 lb
HED 68_	72" x 96"	59"	3,000 – 25,000 lb
HED 69_	72" x 108"	59"	3,000 – 25,000 lb
HED 610_	72" x 120"	59"	3,000 – 25,000 lb
HED 612_	72" x 144"	59"	3,000 – 25,000 lb
HED 77_	84" x 84"	50"	3,000 – 15,000 lb
HED 78_	84" x 96"	59"	3,000 – 25,000 lb
HED 79_	84" x 108"	59"	3,000 – 25,000 lb
HED 710_	84" x 120"	59"	3,000 – 25,000 lb
HED 712_	84" x 144"	59"	3,000 – 25,000 lb
HED 88_	96" x 96"	59"	3,000 – 25,000 lb
HED 89_	96" x 108"	59"	3,000 – 25,000 lb
HED 810_	96" x 120"	59"	3,000 – 25,000 lb
HED 812_	96" x 144"	59"	3,000 – 25,000 lb

Specifying Model Number. Example:

Model **HED6812** is derived from **HED** (Model prefix) **68** (6 foot wide x 8 foot long platform) **12** (12,000 lb capacity). As standard, **HED** are available in 3,000, 4,000, 5,000, 6,000, 8,000, 10,000, 12,000, 15,000, 20,000 and 25,000 lb capacity. For models 15,000 lb capacity and lower side edge load rating is 63% of overall capacity; End edge load rating is 80% of overall rated capacity. For models greater than 15,000 lb capacity and lower side edge load rating is 50% of overall capacity; End edge load rating is 75% of overall rated capacity. Low height (closed) is 12" up to and including 15,000 lb. capacity. Low height (closed) is 20" on all 20,000 and 25,000 lb capacity models. Higher capacities or additional platform sizes are available. Please contact factory to review and process specific project requirements.

Hydraulic Power Unit Considerations

Pentalift offers power units to suit a wide range of applications. As standard (shown below), each model of Pentalift HED dock lift is provided with a remote power Unit, 1 HP, 115/1/60 TEFC motor, 10' of hydraulic hose, push button on 10' cord, pre-wired, full of hydraulic fluid. The power unit HP rating determines the lift speed of the unit (the larger the HP the faster the lift speed), as standard power units are available up to 10 HP.

3 factors to consider when selecting a Power Unit are :

- 1) The distance from the dock lift to the power unit (determines hydraulic hose length and push button control cord length).
- 2) Lift time required (approximately 30 seconds is most common) to determine HP rating.
- 3) Push button controls (straight cord, coil cord, or controls installed on deck).



Pentalift HED 20 Inch Low Height Dock Lift Design Features

The Pentalift HED high capacity dock lift: As shown below, this dock lift maintains the same operational features and benefits of the HED 12 inch low height dock lift with increased structural construction to facilitate heavy load handling capability. These models are frequently utilized to raise and lower a fork lift and its load.

High tensile steel checker plate hinged bridge and platform with structural supports.

Plated access chain:
Prevents operator from falling.

OSHA compliant 42" high removable steel guard rail c/w mid rail and 4" kick plate.



Bevel toe guards for pit mounting protection.

Exclusive PentaFLOW hydraulic bypass cylinder (see previous page) with hydraulic velocity fuse.

Hinged integral maintenance stand.

Heavy duty full length deck beams.

Scissor legs: Solid steel one piece construction with precision reamed holes. All pivot pins are chrome plated.

Dual lower leg rollers, distribute loads equally through scissor leg.

Shipped complete: Finished product, power unit, controls (standard push button control shown) and all other components are factory load-tested and shipped fully assembled, complete with hydraulic fluid.



“Lubricated for life” maintenance free bearings at all pivot points.

Pentalift Dock Lift Optional Features:



Optional hydraulic power units:

Dock lift power units are available to suit any incoming supply voltage and are available in a wide range of horse power ratings. Pentalift adds value by designing and assembling all control panels and wiring "In house". Please contact your Pentalift sales representative to discuss the power unit best suited to your application.

Deck mounted push button control >

Push button on steel post is mounted on the deck.



< Up travel limit switch

Stops units travel at the preset travel dimension every time.



Push Button on Coil Cord

Extends from 4 ft to 20 ft.

Hydraulic pop up chock >

(shown in orange) Prevents fork lift or cart from rolling off lift. Automatically raises into safety position as dock lift raises.



< Toe sensor (shown in red)

Surrounds the perimeter of the lift's platform and electro/hydraulically arrests the downward decent of the lift when an obstruction is encountered.



Hydraulic powered bridge

Raising and lowering of the bridge is controlled by push button.

Other options (not shown with a photograph)

- Removable push button on post on platform.
- Wall mounted push button.
- 2 second warning bell (sounds prior to lift movement).
- Manual lowering valve.
- Overhead door interlocking kit.
- Additional guard rails (platform or floor mount).
- Swing-out night stops.
- Different size bridges.
- Aluminum bridges.



Spring Assisted Bridge

Spring assist reduces the manual force required to raise or lower the bridge into position.

Other Dock Lifts from Pentalift



Pentalift Low Profile Dock Lift Low Profile Surface Mounted Dock Lift



With over 25 years of experience manufacturing quality loading dock equipment, Pentalift is your single-source supplier for dock Lifts, loading dock levelers, dock seals & shelters, vehicle restraints, and much more.

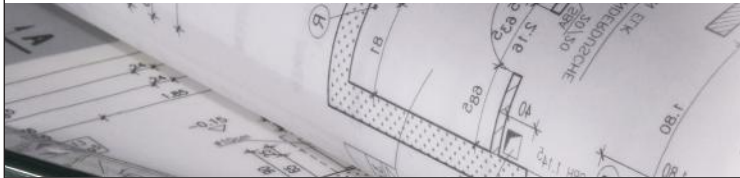

Engineered for Safety



Engineered for Safety!

Pentalift LDL Dock Lift

The Pentalift LDL Dock Lift is offered in the most common sizes for Dock Lifts. It is ideally suited for retail stores or any location that loads or unloads a variety of trucks or trailers. It is highly effective for increasing loading dock safety and efficiency.

Pentalift LDL Dock Lift Design Features

Plated Access Chain: Prevents operator from falling

High tensile steel checker plate hinged bridge and deck plate with Structural Supports

OSHA compliant 42" high removable steel guard rail e/w mid rail and 4" kick plate

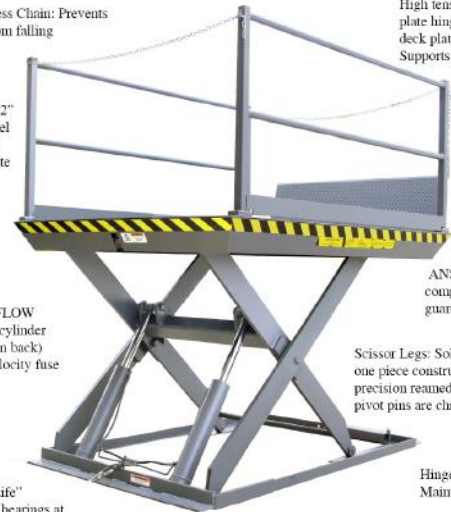

ANSI MH 29.1 compliant beveled toe guards

Exclusive PentaFLOW hydraulic bypass cylinder (see description on back) with hydraulic velocity fuse

Scissor Legs: Solid steel one piece construction with precision reamed holes. All pivot pins are chrome plated.

"Lubricated for Life" maintenance free bearings at all pivot points

Hinged Integral Maintenance Stand

Shipped Complete: Finished product, power units, controls and all other components are factory load-tested and shipped fully assembled, complete with oil.

In addition to the model HED dock lifts shown in this brochure, Pentalift also offers the model LPE surface mounted dock lift, and the model LDL pit mounted dock lift. These dock lifts are described in the literature shown above. A copy of the dock lift brochures as well as our other loading dock equipment brochures, including dock levelers, vehicle restraints, dock seals and truck shelters, and more can be downloaded from our web site (www.pentalift.com) or printed copies are available from your Pentalift representative.

"Our Primary Goal is to engineer and build the best products to ensure the ultimate in user safety and product reliability"

*Paul Pedersen
President
Pentalift Equipment Corporation*

Individual Product Catalogs are available and can also be found on our website.
Pentalift also manufactures a complete line of lift tables for your in plant material handling needs.

Note: Some photos may reflect products with optional features. All Pentalift Equipment Corporation products are subject to design improvement through modification without notice.

Pentalift Equipment Corporation
P.O. Box 1060, Guelph, ON N1H 6N1 Canada P.O. Box 1510, Buffalo, NY 14240 – 1510 USA
Phone: (519) 763 3625 Fax: (519) 763 2894
www.pentalift.com