

Pentalift Series HU Ultima Hydraulic Dock Leveler

The Pentalift Series HU Ultima Hydraulic Dock Leveler provides the Ultimate value in function and structure available in a Dock Leveler.

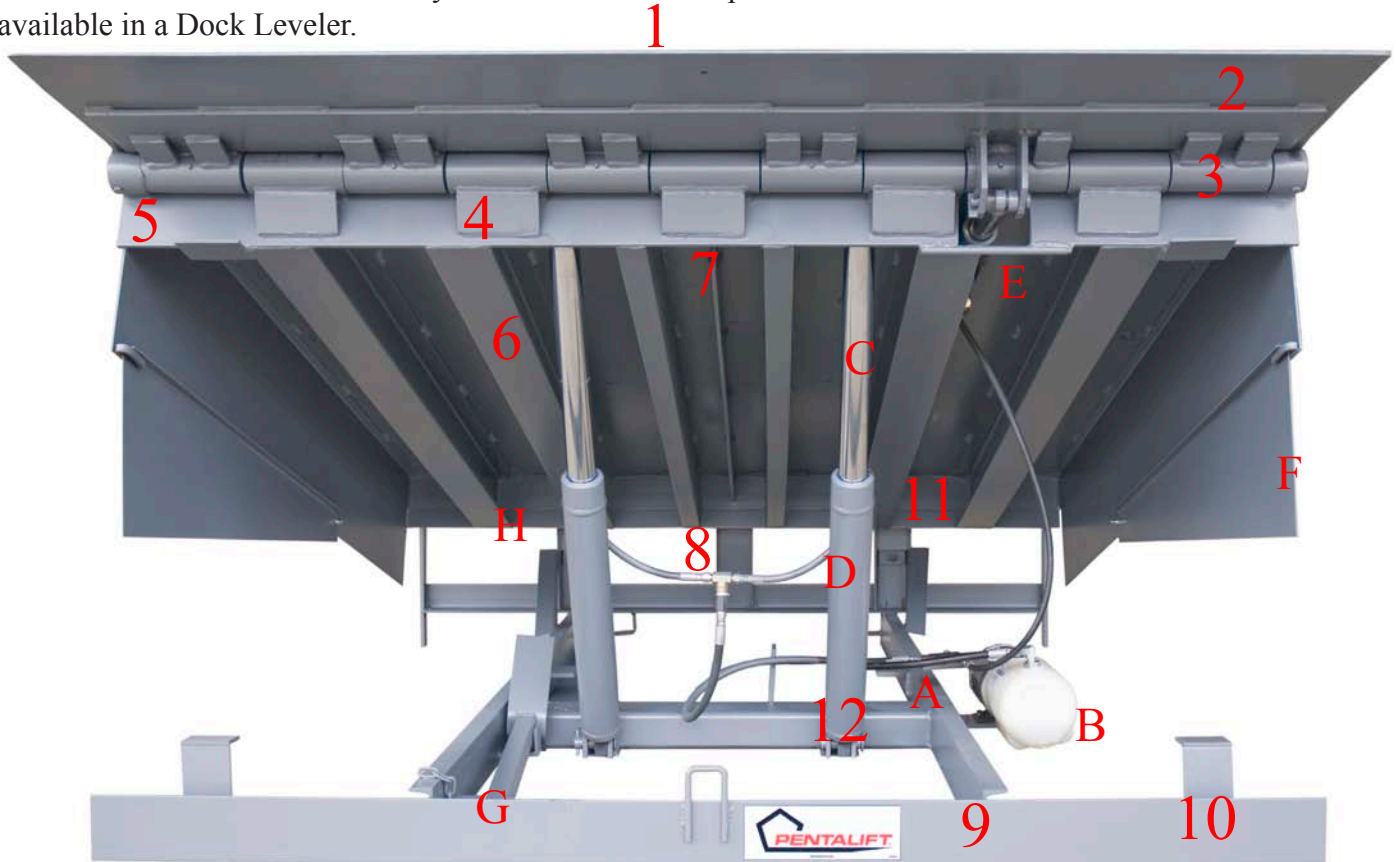

Model HU6845 shown

Series HU Ultima Hydraulic Dock Leveler Structural Features (45000 lbs capacity)

1. Deck Plate High-strength, 4-way safety tread Plate, deck and lip assembly: 55,000 psi yield.
2. Lip Plate Assembly High-strength safety checker plate lip assembly. 1" rear laminated; c/w 3/8" x 6" reinforcing plate, 55,000 psi yield.
3. Full-width self cleaning, heavy-wall hinge tube, 2-1/2" OD X 1-1/2" ID: 70,000 psi yield.
4. 3/8" thick gussets on lip and headboard hinge maximize support.
5. 3/8" Thick, 50,000 psi yield, headboard with bridged gaps.
6. **"I" Beam deck support 6" structural "I" Beams @ 12 lbs per foot.**
7. Central deck beam for added support of three wheeled vehicles.
8. Rear frame assembly features five vertical structural members with eight points of even support for the full width of the rear hinge.
9. Heavy-duty front frame provides full width, cross traffic support and superior building aesthetics.
10. Night locks prevents unauthorized entry when overhead door is locked on top of the Dock Leveler.
11. Full width, structural channel tail board and one piece, full width rear hinge, complete with heavy steel gussets. Pentalift's unique, welded assembly provides a box section for superior support and strength.
12. Dual deck lift cylinders.

Note: In addition to the 45,000 lbs capacity model shown here, Series HU Ultima Hydraulic Dock Levelers are available in 30,000 and 35,000 lbs capacities. These capacities maintain "I" Beam construction. Lip plate thickness, "I" Beam sizing, lip hinge tubes and lip hinge pin diameters are all reduced in size relative to the 45,000 lbs capacity model reflected above to correspond with the capacity ratings reduction. These two capacities incorporate single deck cylinders. Contact your Pentalift Representative for more details.